

NB7N017MEVB

NB7N017M Evaluation Board User's Manual



ON Semiconductor®

<http://onsemi.com>

EVAL BOARD USER'S MANUAL

Description

This document describes the NB7N017M evaluation board and the appropriate lab test setups. It should be used in conjunction with the NB7N017M data sheet which contains full technical details on the device specification and operation. This evaluation board is offered as a convenience for the customers interested in performing their own engineering characterization and performance assessment of the NB7N017M. The board provides a high bandwidth 50 Ω controlled impedance environment.

The evaluation board is designed to facilitate a quick evaluation of the NB7N017M GigaComm™ 8-bit dual modulus programmable divider/prescaler. The current mode logic (CML) output ensures minimal noise and fast switching edges.

This evaluation board manual contains:

- Information on NB7N017MEVB Evaluation Board
- Appropriate Lab Test Setup
- Bill of Materials

What measurements can you expect to make?

With this evaluation board, the following measurements could be performed in single-ended or differential modes of operation:

- Jitter
- Frequency Response
- Output Rise and Fall Time

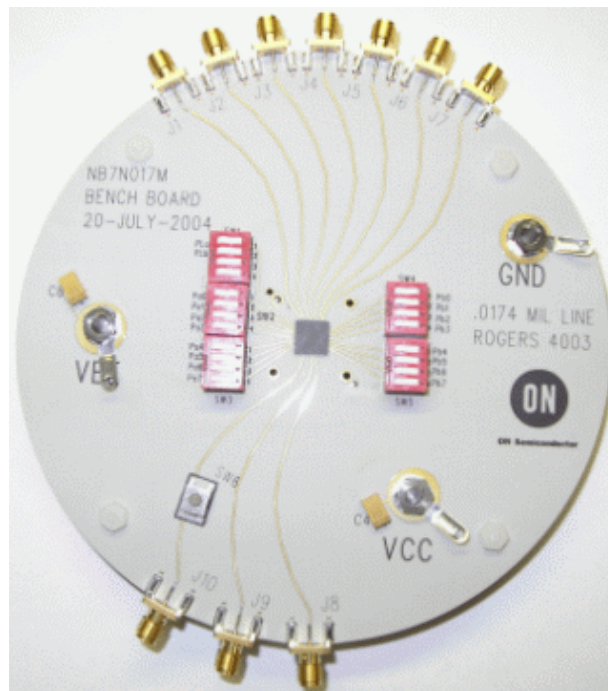

Figure 1. Evaluation Board Photo

NB7N017MEVB

Board Lay-Up

The NB7N017MEVB evaluation board is implemented in four layers (Figure 2, Evaluation Board Lay-up). The first layer or primary trace layer is 5 mil thick Rogers RO4003 material, which is designed to have equal electrical length on all signal traces from the device under the test (DUT) to the sense output. The second layer is the 1.0 oz copper ground plane. The FR4 dielectric material is placed between second and third layer and between third and fourth layer. The third layer is also 1.0 oz copper power plane. The fourth layer is the secondary trace layer.

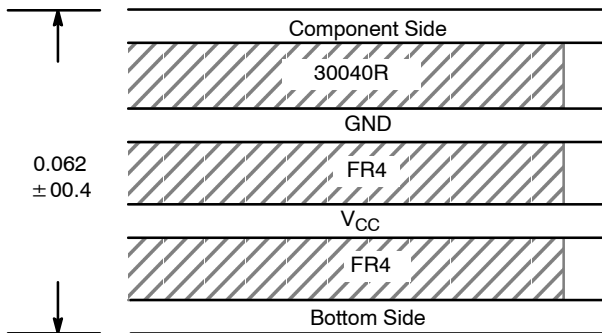
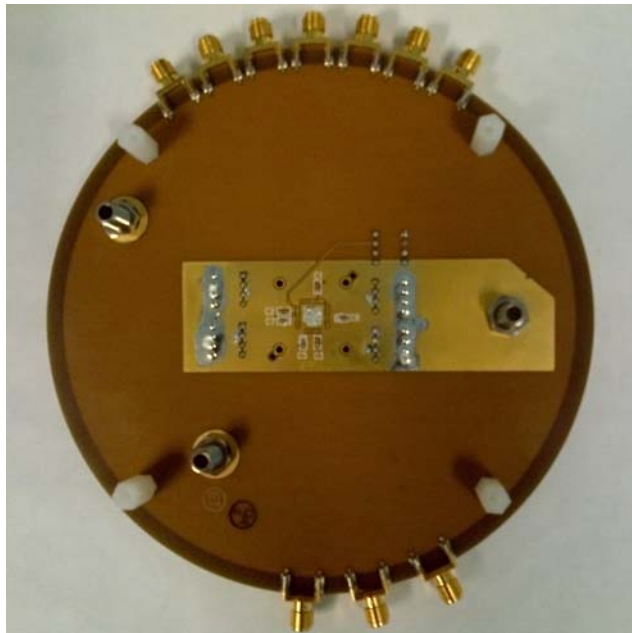

Figure 2. Evaluation Board Lay-Up

Board Layout

The NB7N017MEVB evaluation board was designed to be versatile (see evaluation board schematic Figure 5). The input and output signal trace layout of the evaluation board is shown in Figure 3. The high-speed input and output pins are on a controlled 50 Ω impedance trace to an SMA connector. Other control pins (Pa[0:7] and Pb[0:7]) are connected to a switch for ease of programmability. The master RESET can either be controlled by a switch (SW6) or an input signal (J10).



(Bottom View)

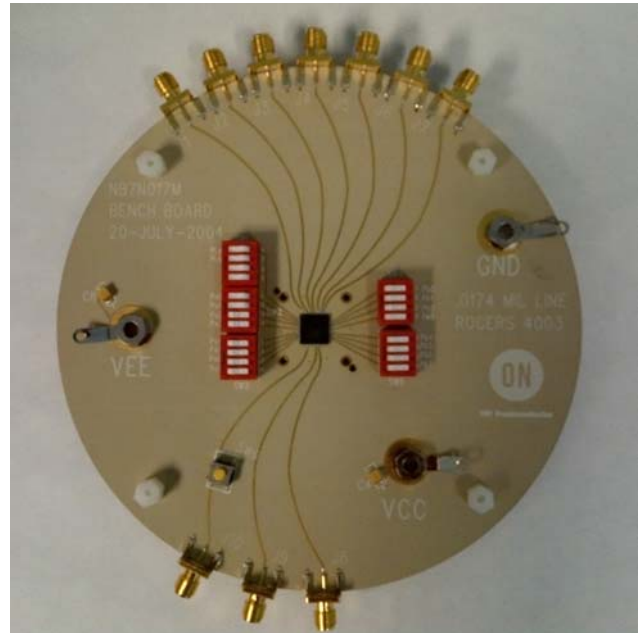

(Top View)

Figure 3. Evaluation Board

NB7N017MEVB

Power Supplies

The NB7N017M is powered by $|V_{CC} - V_{EE}| = 3.3$ V power supplies. For straightforward lab setup operation, negative voltages is recommended to enable the $50\ \Omega$ internal impedance of the oscilloscope to be used as a termination for the CML signals ($V_{CC} = 0.0$ V, $V_{EE} = -3.3$ V and $GND = 0.0$ V).

It is recommended to add capacitors (C4 and C8 are $22\ \mu\text{F}$ and C1, C2, C3, C5, C6, and C7 are $0.1\ \mu\text{F}$) to reduce the unwanted noise from the power supplies. Adding capacitors can improve the edge rates, reduce over shoot, and under shoot. Evaluation board provides several capacitor pads to add capacitors.

Termination

CML outputs need to be terminated to V_{CC} via a $50\ \Omega$ resistor. The input pins contain internal $50\ \Omega$ resistors (VT pins). The VT pins are tied to V_{CC} which limits the input configuration of this device on this evaluation board.

NOTE: The test measurement device must contain $50\ \Omega$ termination.

1. Connect appropriate power supplies. ($V_{CC} = 0.0$ V, $V_{EE} = -3.3$ V, and $GND = 0.0$ V).
2. Connect input signals to the appropriate SMA connectors. Configure input signals according to the device data sheet.
3. Connect a test measurement device on the device output SMA connectors.

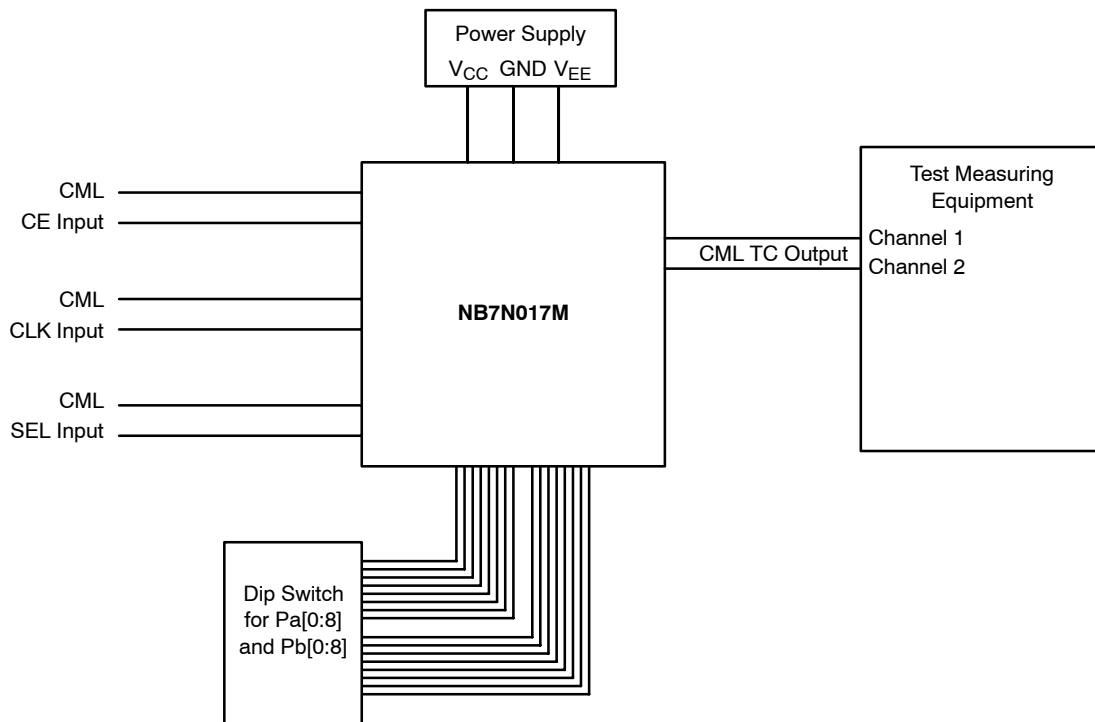

Figure 4. Typical Lab Setup

NB7N017MEVB

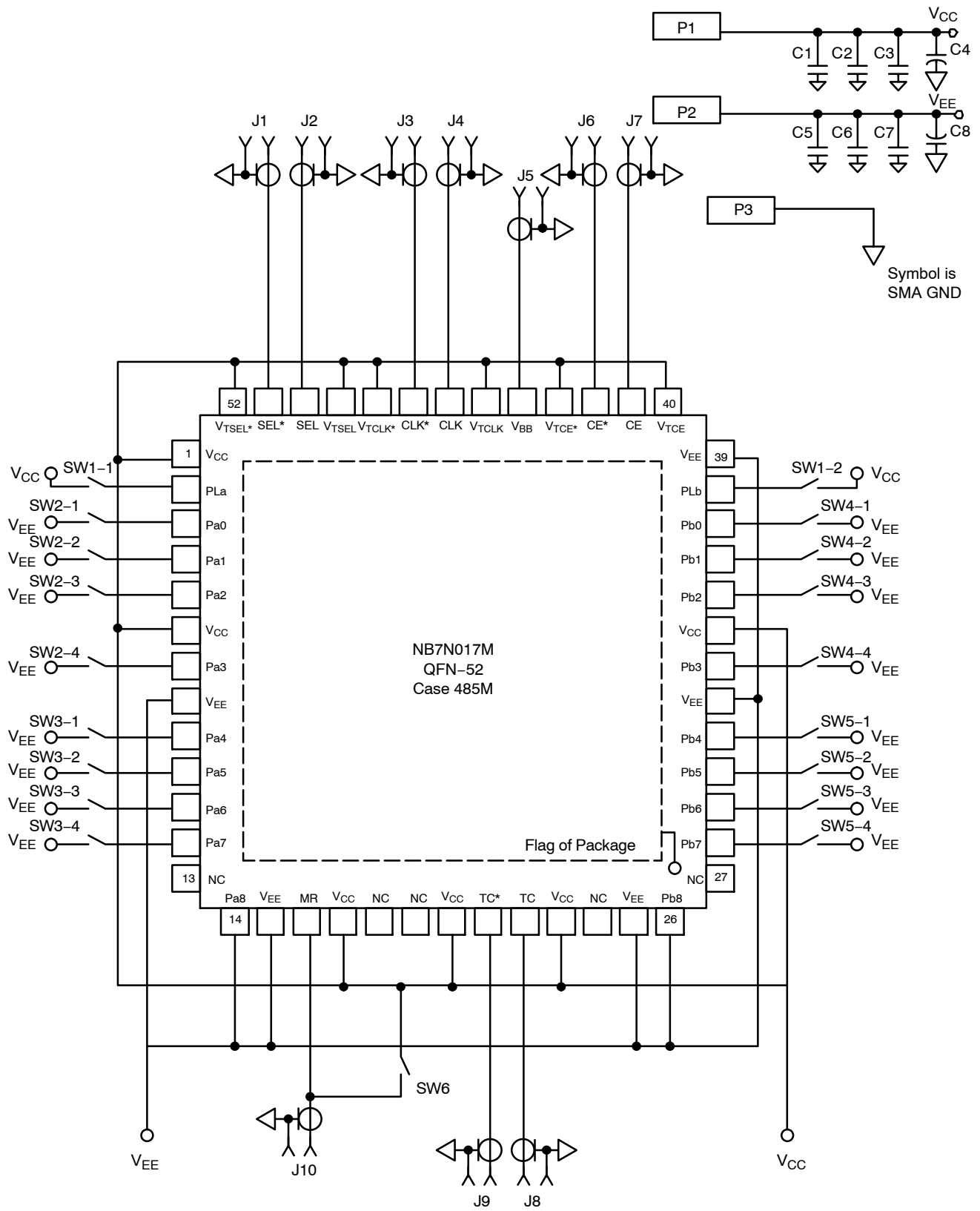

Figure 5. Evaluation Board Schematic

NB7N017MEVB

Table 1. BILL OF MATERIALS FOR NB7N017MEVB

Components	Manufacturer	Description	Part Number	Web Site
SMA Connector	Johnson	SMA Connector, Side Launch, Gold Plated	142-0701-801	
Chip Capacitor	Kemet*	0603 0.1 μ F \pm 10%	C0603C104K4RAC	www.newark.com
		22 μ F \pm 10%	T491C226K016AS	
Banana Jack	SPC*	Banana Jack Female	813	www.newark.com
Evaluation Board	ON Semiconductor	NB7N017M Evaluation Board	NB7N017MEVB	http://www.onsemi.com
Device Samples	ON Semiconductor	3.3 V 8-bit Divider/Prescaler with CML Output	NB7N017M	http://www.onsemi.com
Switch	Grayhill	Dip Switch, 1 Position	765B04	
Switch	Grayhill	Momentary Switch	95C04A3GW	

*Components are available through most distributors, i.e. www.newark.com, www.digikey.com

GigaComm is a trademark of Semiconductor Components Industries, LLC (SCILLC).

ON Semiconductor and  are registered trademarks of Semiconductor Components Industries, LLC (SCILLC). SCILLC reserves the right to make changes without further notice to any products herein. SCILLC makes no warranty, representation or guarantee regarding the suitability of its products for any particular purpose, nor does SCILLC assume any liability arising out of the application or use of any product or circuit, and specifically disclaims any and all liability, including without limitation special, consequential or incidental damages. "Typical" parameters which may be provided in SCILLC data sheets and/or specifications can and do vary in different applications and actual performance may vary over time. All operating parameters, including "Typicals" must be validated for each customer application by customer's technical experts. SCILLC does not convey any license under its patent rights nor the rights of others. SCILLC products are not designed, intended, or authorized for use as components in systems intended for surgical implant into the body, or other applications intended to support or sustain life, or for any other application in which the failure of the SCILLC product could create a situation where personal injury or death may occur. Should Buyer purchase or use SCILLC products for any such unintended or unauthorized application, Buyer shall indemnify and hold SCILLC and its officers, employees, subsidiaries, affiliates, and distributors harmless against all claims, costs, damages, and expenses, and reasonable attorney fees arising out of, directly or indirectly, any claim of personal injury or death associated with such unintended or unauthorized use, even if such claim alleges that SCILLC was negligent regarding the design or manufacture of the part. SCILLC is an Equal Opportunity/Affirmative Action Employer. This literature is subject to all applicable copyright laws and is not for resale in any manner.

PUBLICATION ORDERING INFORMATION

LITERATURE FULFILLMENT:

Literature Distribution Center for ON Semiconductor
P.O. Box 5163, Denver, Colorado 80217 USA
Phone: 303-675-2175 or 800-344-3860 Toll Free USA/Canada
Fax: 303-675-2176 or 800-344-3867 Toll Free USA/Canada
Email: orderlit@onsemi.com

N. American Technical Support: 800-282-9855 Toll Free
USA/Canada
Europe, Middle East and Africa Technical Support:
Phone: 421 33 790 2910
Japan Customer Focus Center
Phone: 81-3-5817-1050

ON Semiconductor Website: www.onsemi.com

Order Literature: <http://www.onsemi.com/orderlit>

For additional information, please contact your local Sales Representative



Стандарт Электрон Связь

Мы молодая и активно развивающаяся компания в области поставок электронных компонентов. Мы поставляем электронные компоненты отечественного и импортного производства напрямую от производителей и с крупнейших складов мира.

Благодаря сотрудничеству с мировыми поставщиками мы осуществляем комплексные и плановые поставки широчайшего спектра электронных компонентов.

Собственная эффективная логистика и склад в обеспечивает надежную поставку продукции в точно указанные сроки по всей России.

Мы осуществляем техническую поддержку нашим клиентам и предпродажную проверку качества продукции. На все поставляемые продукты мы предоставляем гарантию .

Осуществляем поставки продукции под контролем ВП МО РФ на предприятия военно-промышленного комплекса России , а также работаем в рамках 275 ФЗ с открытием отдельных счетов в уполномоченном банке. Система менеджмента качества компании соответствует требованиям ГОСТ ISO 9001.

Минимальные сроки поставки, гибкие цены, неограниченный ассортимент и индивидуальный подход к клиентам являются основой для выстраивания долгосрочного и эффективного сотрудничества с предприятиями радиоэлектронной промышленности, предприятиями ВПК и научно-исследовательскими институтами России.

С нами вы становитесь еще успешнее!

Наши контакты:

Телефон: +7 812 627 14 35

Электронная почта: sales@st-electron.ru

Адрес: 198099, Санкт-Петербург,
Промышленная ул, дом № 19, литера Н,
помещение 100-Н Офис 331