

# NHD-0240AZ-FL-GBW

## Character Liquid Crystal Display Module

NHD- Newhaven Display  
0240- 2 lines x 40 characters  
AZ- Model  
F- Transflective  
L- Yellow/Green LED Backlight  
G- STN – Gray  
B- 6:00 view  
W- Wide Temp. (-20°C ~+70°C)  
**RoHS Compliant**

**Newhaven Display International, Inc.**

2511 Technology Drive, Suite 101

Elgin IL, 60124

Ph: 847-844-8795

Fax: 847-844-8796

[www.newhavendisplay.com](http://www.newhavendisplay.com)

[nhtech@newhavendisplay.com](mailto:nhtech@newhavendisplay.com)

[nhsales@newhavendisplay.com](mailto:nhsales@newhavendisplay.com)

## Document Revision History

| Revision | Date       | Description                        | Changed by |
|----------|------------|------------------------------------|------------|
| 0        | 10/21/2008 | Initial Release                    | -          |
| 1        | 11/4/2009  | User Guide Reformat                | MC         |
| 2        | 12/17/2009 | Updated Backlight Supply Current   | MC         |
| 3        | 1/10/2011  | Updated Controller Information     | JT         |
| 4        | 5/6/2011   | Electrical characteristics updated | AK         |

## Functions and Features

- 2 lines x 40 characters
- Built-in controllers (ST7066U)
- +5.0V Power Supply
- 1/16 duty, 1/5 bias
- RoHS compliant

Mechanical Drawing

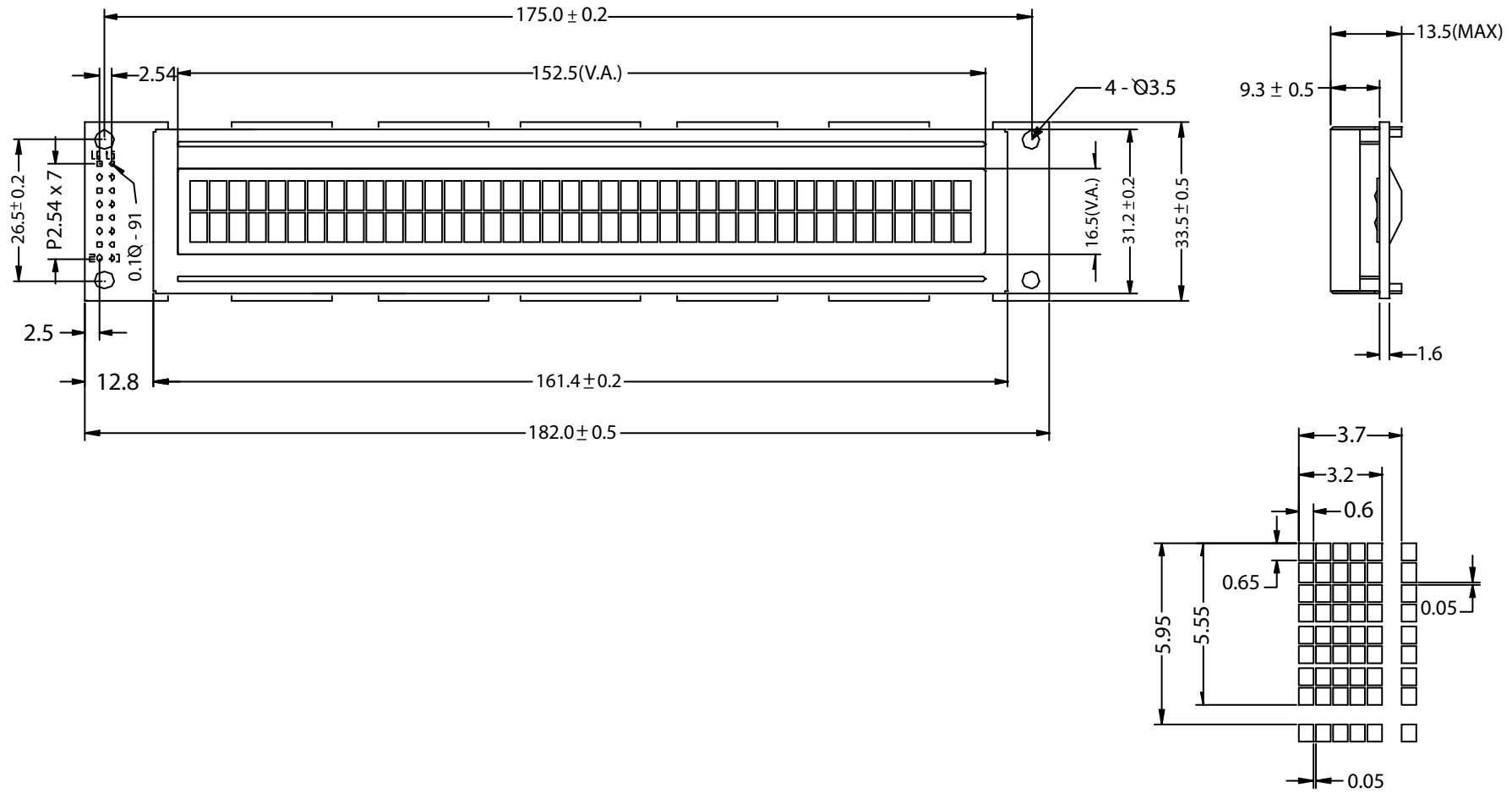

Newhaven Display  
NHD-0240AZ-FL-GBW

## Pin Description and Wiring Diagram

| Pin No. | Symbol  | External Connection | Function Description   |
|---------|---------|---------------------|--|
| 1       | Vss     | Power Supply        | Ground   |
| 2       | VDD     | Power Supply        | Supply voltage for logic (+5.0V)   |
| 3       | V0      | Power Supply        | Power supply for contrast (approx. 0.4V)   |
| 4       | RS      | MPU                 | Register select signal. RS=0: Command, RS=1: Data  |
| 5       | R/W     | MPU                 | Read/Write select signal, R/W=1: Read R/W:=0: Write  |
| 6       | E       | MPU                 | Operation enable signal. Falling edge triggered.   |
| 7-10    | DB0-DB3 | MPU                 | Four low order bi-directional three-state data bus lines. These four are no used during 4-bit operation. |
| 11-14   | DB4-DB7 | MPU                 | Four high order bi-directional three-state data bus lines.   |
| 15      | LED+    | Power Supply        | Power supply for LED Backlight (+5.0V via on-board resistor)   |
| 16      | LED-    | Power Supply        | Ground for backlight   |

Recommended LCD connector: 2.54mm pitch pins

Backlight connector: --- Mates with: ---



## Electrical Characteristics

| Item                        | Symbol | Condition         | Min.    | Typ. | Max. | Unit |
|-----------------------------|--------|-------------------|---------|------|------|------|
| Operating Temperature Range | Top    | Absolute Max      | -20     | -    | +70  | °C   |
| Storage Temperature Range   | Tst    | Absolute Max      | -30     | -    | +80  | °C   |
| Supply Voltage              | VDD    |                   | 4.7     | 5.0  | 5.5  | V    |
| Supply Current              | IDD    | Ta=25°C, VDD=5.0V | -       | 1.5  | 2.5  | mA   |
| Supply for LCD (contrast)   | VDD-V0 | Ta=25°C           | -       | 4.6  | -    | V    |
| "H" Level input             | Vih    |                   | 0.7 VDD | -    | VDD  | V    |
| "L" Level input             | Vil    |                   | 0       | -    | 0.6  | V    |
| "H" Level output            | Voh    |                   | 3.9     | -    | -    | V    |
| "L" Level output            | Vol    |                   | -       | -    | 0.4  | V    |
|                             |        |                   |         |      |      |      |
| Backlight Supply Voltage    | Vled   | -                 | -       | 5.0  | -    | V    |
| Backlight Supply Current    | Iled   | Vled=5.0V         | -       | 120  | -    | mA   |

## Optical Characteristics

| Item                               | Symbol | Condition | Min. | Typ. | Max. | Unit |
|------------------------------------|--------|-----------|------|------|------|------|
| Viewing Angle – Vertical (top)     | AV     | Cr ≥ 2    | -    | 25   | -    | °    |
| Viewing Angle – Vertical (bottom)  | AV     | Cr ≥ 2    | -    | 70   | -    | °    |
| Viewing Angle – Horizontal (left)  | AH     | Cr ≥ 2    | -    | 30   | -    | °    |
| Viewing Angle – Horizontal (right) | AH     | Cr ≥ 2    | -    | 30   | -    | °    |
| Contrast Ratio                     | Cr     |           | -    | 2    | -    | -    |
| Response Time (rise)               | Tr     | -         | -    | 120  | 150  | ms   |
| Response Time (fall)               | Tf     | -         | -    | 120  | 150  | ms   |

## Controller Information

Built-in ST7066U. Download specification at [http://www.newhavendisplay.com/app\\_notes/ST7066U.pdf](http://www.newhavendisplay.com/app_notes/ST7066U.pdf)

## Display character address code

|                  |    |    |    |    |    |       |     |     |     |     |
|------------------|----|----|----|----|----|-------|-----|-----|-----|-----|
| Display position | 1  | 2  | 3  | 4  | 5  | ----- | 37  | 38  | 39  | 40  |
| DDRAM address    | 00 | 01 | 02 | 03 | 04 | ----- | 24H | 25H | 26H | 27H |
| DDRAM address    | 40 | 41 | 42 | 43 | 44 | ----- | 64H | 65H | 66H | 67H |

## Command Table

| Instruction                | Instruction Code |     |     |     |     |     |     |     |     |     | Description | Description Time<br>(270KHz)   |         |
|----------------------------|------------------|-----|-----|-----|-----|-----|-----|-----|-----|-----|-------------|--|---------|
|                            | RS               | R/W | DB7 | DB6 | DB5 | DB4 | DB3 | DB2 | DB1 | DB0 |             |  |         |
| Clear Display              | 0                | 0   | 0   | 0   | 0   | 0   | 0   | 0   | 0   | 0   | 1           | Write "20H" to DDRAM. and set DDRAM address to "00H" from AC   | 1.52 ms |
| Return Home                | 0                | 0   | 0   | 0   | 0   | 0   | 0   | 0   | 0   | 1   | x           | Set DDRAM address to "00H" from AC and return cursor to its original position if shifted. The contents of DDRAM are not changed. | 1.52 ms |
| Entry Mode Set             | 0                | 0   | 0   | 0   | 0   | 0   | 0   | 0   | 1   | I/D | S           | Sets cursor move direction and specifies display shift. These operations are performed during data write and read.               | 37 us   |
| Display ON/OFF             | 0                | 0   | 0   | 0   | 0   | 0   | 0   | 1   | D   | C   | B           | D=1:entire display on<br>C=1:cursor on<br>B=1:cursor position on   | 37 us   |
| Cursor or Display Shift    | 0                | 0   | 0   | 0   | 0   | 0   | 1   | S/C | R/L | x   | x           | Set cursor moving and display shift control bit, and the direction, without changing DDRAM data.                                 | 37 us   |
| Function Set               | 0                | 0   | 0   | 0   | 1   | DL  | N   | F   | x   | x   |             | DL:interface data is 8/4 bits<br>N:number of line is 2/1<br>F:font size is 5x11/5x8  | 37 us   |
| Set CGRAM address          | 0                | 0   | 0   | 1   | AC5 | AC4 | AC3 | AC2 | AC1 | AC0 |             | Set CGRAM address in address counter   | 37 us   |
| Set DDRAM address          | 0                | 0   | 1   | AC6 | AC5 | AC4 | AC3 | AC2 | AC1 | AC0 |             | Set DDRAM address in address counter   | 37 us   |
| Read Busy flag and address | 0                | 1   | BF  | AC6 | AC5 | AC4 | AC3 | AC2 | AC1 | AC0 |             | Whether during internal operation or not can be known by reading BF. The contents of address counter can also be read.           | 0 us    |
| Write data to RAM          | 1                | 0   | D7  | D6  | D5  | D4  | D3  | D2  | D1  | D0  |             | Write data into internal RAM (DDRAM/CGRAM)   | 37 us   |
| Read data from RAM         | 1                | 1   | D7  | D6  | D5  | D4  | D3  | D2  | D1  | D0  |             | Read data from internal RAM (DDRAM/CGRAM)  | 37 us   |

# Built-in Font Table

| Lower 4 Bits \ Upper 4 Bits | 0000       | 0001 | 0010 | 0011 | 0100 | 0101 | 0110 | 0111 | 1000 | 1001 | 1010 | 1011 | 1100 | 1101 | 1110 | 1111 |
|-----------------------------|------------|------|------|------|------|------|------|------|------|------|------|------|------|------|------|------|
| xxxx0000                    | CG RAM (1) |      |      | 0    | a    | P    | `    | P    |      |      |      | -    | 夕    | ミ    | &    | P    |
| xxxx0001                    | (2)        |      | !    | 1    | A    | Q    | a    | q    |      |      | 。    | ア    | チ    | △    | ä    | q    |
| xxxx0010                    | (3)        |      | "    | 2    | B    | R    | b    | r    |      |      | 「    | イ    | ツ    | ×    | ß    | θ    |
| xxxx0011                    | (4)        |      | #    | 3    | C    | S    | c    | s    |      |      | 」    | ウ    | テ    | モ    | è    | ø    |
| xxxx0100                    | (5)        |      | \$   | 4    | D    | T    | d    | t    |      |      | 、    | エ    | ト    | ト    | μ    | Ω    |
| xxxx0101                    | (6)        |      | %    | 5    | E    | U    | e    | u    |      |      | ・    | オ    | ナ    | 1    | œ    | ü    |
| xxxx0110                    | (7)        |      | &    | 6    | F    | V    | f    | v    |      |      | ヲ    | カ    | ニ    | ヨ    | ρ    | Σ    |
| xxxx0111                    | (8)        |      | '    | 7    | G    | W    | g    | w    |      |      | ヲ    | キ    | ヌ    | ラ    | g    | π    |
| xxxx1000                    | (1)        |      | <    | 8    | H    | X    | h    | x    |      |      | イ    | ク    | ネ    | リ    | γ    | Σ    |
| xxxx1001                    | (2)        |      | >    | 9    | I    | Y    | i    | y    |      |      | ウ    | ケ    | ル    | ル    | ı    | ı    |
| xxxx1010                    | (3)        |      | *    | :    | J    | Z    | j    | z    |      |      | エ    | コ    | ハ    | レ    | j    | ç    |
| xxxx1011                    | (4)        |      | +    | ;    | K    | [    | k    | [    |      |      | オ    | サ    | ヒ    | ロ    | *    | π    |
| xxxx1100                    | (5)        |      | ,    | <    | L    | ¥    | l    | l    |      |      | カ    | シ    | フ    | ワ    | φ    | π    |
| xxxx1101                    | (6)        |      | -    | =    | M    | ]    | m    | ]    |      |      | ユ    | ス    | ハ    | ン    | も    | ÷    |
| xxxx1110                    | (7)        |      | .    | >    | N    | ^    | n    | →    |      |      | ヨ    | セ    | ホ    | °    | ñ    |      |
| xxxx1111                    | (8)        |      | /    | ?    | O    | _    | o    | ←    |      |      | ッ    | ソ    | マ    | °    | ö    | ■    |

## Example Initialization Program

8-bit Initialization:

```

/*****/
void command(char i)
{
    P1 = i;                //put data on output Port
    D_I =0;                //D/I=LOW : send instruction
    R_W =0;                //R/W=LOW : Write
    E = 1;
    Delay(1);              //enable pulse width >= 300ns
    E = 0;                 //Clock enable: falling edge
}
/*****/
void write(char i)
{
    P1 = i;                //put data on output Port
    D_I =1;                //D/I=LOW : send data
    R_W =0;                //R/W=LOW : Write
    E = 1;
    Delay(1);              //enable pulse width >= 300ns
    E = 0;                 //Clock enable: falling edge
}
/*****/
void init()
{
    E = 0;
    Delay(100);            //Wait >15 msec after power is applied
    command(0x30);         //command 0x30 = Wake up
    Delay(30);             //must wait 5ms, busy flag not available
    command(0x30);         //command 0x30 = Wake up #2
    Delay(10);             //must wait 160us, busy flag not available
    command(0x30);         //command 0x30 = Wake up #3
    Delay(10);             //must wait 160us, busy flag not available
    command(0x38);         //Function set: 8-bit/2-line
    command(0x10);         //Set cursor
    command(0x0c);         //Display ON; Cursor ON
    command(0x06);         //Entry mode set
}
/*****/
```



4-bit Initialization:

```

/*****/
void command(char i)
{
    P1 = i;                //put data on output Port
    D_I = 0;              //D/I=LOW : send instruction
    R_W = 0;              //R/W=LOW : Write
    Nybble();             //Send lower 4 bits
    i = i<<4;             //Shift over by 4 bits
    P1 = i;                //put data on output Port
    Nybble();             //Send upper 4 bits
}
/*****/
void write(char i)
{
    P1 = i;                //put data on output Port
    D_I = 1;              //D/I=HIGH : send data
    R_W = 0;              //R/W=LOW : Write
    Nybble();             //Clock lower 4 bits
    i = i<<4;             //Shift over by 4 bits
    P1 = i;                //put data on output Port
    Nybble();             //Clock upper 4 bits
}
/*****/
void Nybble()
{
    E = 1;
    Delay(1);              //enable pulse width >= 300ns
    E = 0;                 //Clock enable: falling edge
}
/*****/
void init()
{
    P1 = 0;
    P3 = 0;
    Delay(100);            //Wait >15 msec after power is applied
    P1 = 0x30;             //put 0x30 on the output port
    Delay(30);             //must wait 5ms, busy flag not available
    Nybble();              //command 0x30 = Wake up
    Delay(10);             //must wait 160us, busy flag not available
    Nybble();              //command 0x30 = Wake up #2
    Delay(10);             //must wait 160us, busy flag not available
    Nybble();              //command 0x30 = Wake up #3
    Delay(10);             //can check busy flag now instead of delay
    P1= 0x20;              //put 0x20 on the output port
    Nybble();              //Function set: 4-bit interface
    command(0x28);         //Function set: 4-bit/2-line
    command(0x10);         //Set cursor
    command(0x0F);         //Display ON; Blinking cursor
    command(0x06);         //Entry Mode set
}
/*****/

```

## Quality Information

| Test Item                             | Content of Test   | Test Condition  | Note |
|---------------------------------------|---|---|------|
| High Temperature storage              | Endurance test applying the high storage temperature for a long time.   | +80°C , 48hrs   | 2    |
| Low Temperature storage               | Endurance test applying the low storage temperature for a long time.  | -30°C , 48hrs   | 1,2  |
| High Temperature Operation            | Endurance test applying the electric stress (voltage & current) and the high thermal stress for a long time.                    | +70°C 48hrs   | 2    |
| Low Temperature Operation             | Endurance test applying the electric stress (voltage & current) and the low thermal stress for a long time.                     | -20°C , 48hrs   | 1,2  |
| High Temperature / Humidity Operation | Endurance test applying the electric stress (voltage & current) and the high thermal with high humidity stress for a long time. | +40°C , 90% RH , 48hrs  | 1,2  |
| Thermal Shock resistance              | Endurance test applying the electric stress (voltage & current) during a cycle of low and high thermal stress.                  | 0°C,30min -> 25°C,5min -> 50°C,30min = 1 cycle<br>10 cycles                         |      |
| Vibration test                        | Endurance test applying vibration to simulate transportation and use.   | 10-55Hz , 15mm amplitude.<br>60 sec in each of 3 directions X,Y,Z<br>For 15 minutes | 3    |
| Static electricity test               | Endurance test applying electric static discharge.  | VS=800V, RS=1.5kΩ, CS=100pF<br>One time   |      |

**Note 1:** No condensation to be observed.

**Note 2:** Conducted after 4 hours of storage at 25°C, 0%RH.

**Note 3:** Test performed on product itself, not inside a container.

## Precautions for using LCDs/LCMs

See Precautions at [www.newhavendisplay.com/specs/precautions.pdf](http://www.newhavendisplay.com/specs/precautions.pdf)

## Warranty Information and Terms & Conditions

[http://www.newhavendisplay.com/index.php?main\\_page=terms](http://www.newhavendisplay.com/index.php?main_page=terms)



## Стандарт Электрон Связь

Мы молодая и активно развивающаяся компания в области поставок электронных компонентов. Мы поставляем электронные компоненты отечественного и импортного производства напрямую от производителей и с крупнейших складов мира.

Благодаря сотрудничеству с мировыми поставщиками мы осуществляем комплексные и плановые поставки широчайшего спектра электронных компонентов.

Собственная эффективная логистика и склад в обеспечивает надежную поставку продукции в точно указанные сроки по всей России.

Мы осуществляем техническую поддержку нашим клиентам и предпродажную проверку качества продукции. На все поставляемые продукты мы предоставляем гарантию .

Осуществляем поставки продукции под контролем ВП МО РФ на предприятия военно-промышленного комплекса России , а также работаем в рамках 275 ФЗ с открытием отдельных счетов в уполномоченном банке. Система менеджмента качества компании соответствует требованиям ГОСТ ISO 9001.

Минимальные сроки поставки, гибкие цены, неограниченный ассортимент и индивидуальный подход к клиентам являются основой для выстраивания долгосрочного и эффективного сотрудничества с предприятиями радиоэлектронной промышленности, предприятиями ВПК и научно-исследовательскими институтами России.

С нами вы становитесь еще успешнее!

### Наши контакты:

**Телефон:** +7 812 627 14 35

**Электронная почта:** [sales@st-electron.ru](mailto:sales@st-electron.ru)

**Адрес:** 198099, Санкт-Петербург,  
Промышленная ул, дом № 19, литера Н,  
помещение 100-Н Офис 331