



# Atmel AVR2042: REB Controller Base Board - Hardware User Manual

## Features

- High-performance, low-power 8/16-bit Atmel® AVR® XMEGA® ATxmega256A3 microcontroller
  - 256KB in-system, self-programmable flash
  - 8KB boot code section with independent lock bits
  - 16KB internal SRAM
  - 4KB EEPROM
- 4Mb serial flash for support of over-the-air (OTA) upgrades
- Programming interface
- Fully functional wireless node in combination with the Atmel Radio Extender Board (REB)
- Powered by two AAA batteries for stand-alone operation

## 1 Introduction

This application note describes the Atmel REB Controller Base Board (REB-CBB). Detailed information about its functionality, its interfaces, the microcontroller programming, and the PCB design is given in the individual sections.

The REB-CBB is intended to serve as a microcontroller platform for the Atmel Radio Extender Board (REB) family. The REB connected to a REB-CBB forms a battery powered, fully functional, and portable wireless node.

**Figure 1-1.** REB controller base board.

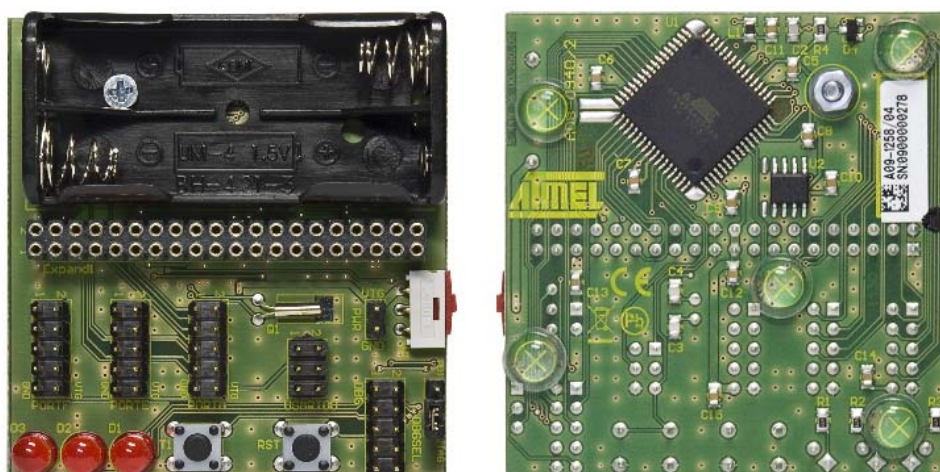

## 8-bit Atmel Microcontrollers

## Application Note





## 2 Disclaimer

Typical values contained in this application note are based on simulations and on testing of individual examples.

Any information about third-party materials or parts is included in this document for convenience. The vendor may have changed the information that has been published. Check the individual vendor information for the latest changes.

## 3 Overview

The Atmel REB-CBB is designed to interface directly to a radio extender board. The combination of the two boards form a battery powered, fully functional, portable wireless node. The setup provides an ideal platform to:

- Evaluate the outstanding performance of the Atmel radio transceivers
- Test the unique radio transceiver hardware support for the IEEE® 802.15.4 standard [1]
- Test the enhanced radio transceiver feature set
- Develop applications capable of hosting a ZigBee® stack

Table 3-1 lists the available radio extender boards and related radio transceivers.

**Table 3-1.** Supported radio extender boards.

Board name	Comment	Radio transceiver	Available evaluation kit
REB212	SMA connector	AT86RF212	N/A <sup>(1)</sup>
REB231	SMA connector	AT86RF231	N/A <sup>(1)</sup>
REB231ED	Antenna diversity	AT86RF231	ATREB231ED-EK
REB231FE2	Antenna diversity, front end module	AT86RF231	ATREB231FE2-EK
REB232ED	Antenna diversity	AT86RF232	ATREB232ED-EK
REB233SMAD	Antenna diversity, SMA connector	AT86RF233	ATREB233SMAD-EK

Note: 1. Currently there exists no Evaluation Kit, but the plain radio extender is purchasable from <http://www.dresden-elektronik.de/shop/>.

The REB-CBB is assembled with an 8-bit Atmel AVR ATxmega256A3 microcontroller. It offers a connector for programming and debugging, suitable to connect an Atmel AVR JTAGICE mkII programmer. A connector to attach an asynchronous serial interface allows interfacing to a PC host for control and data exchange tasks.

Figure 3-1 shows a development and evaluation setup using the REB-CBB in combination with the REB231ED radio extender board.

**Figure 3-1.** Atmel REB-CBB connected to an Atmel REB231ED with an RS232 cable plugged in and an Atmel AVR JTAGICE mkII programming interface.



## 4 Mechanical description

The REB-CBB is manufactured using a two-layer printed circuit board (PCB). All active components are mounted on the bottom side, and all connectors and user I/Os are located on the top side using through-hole components. The radio extender board is plugged into the 2 × 20 female header, Expand1, vertically.

**Figure 4-1.** Mechanical outline.

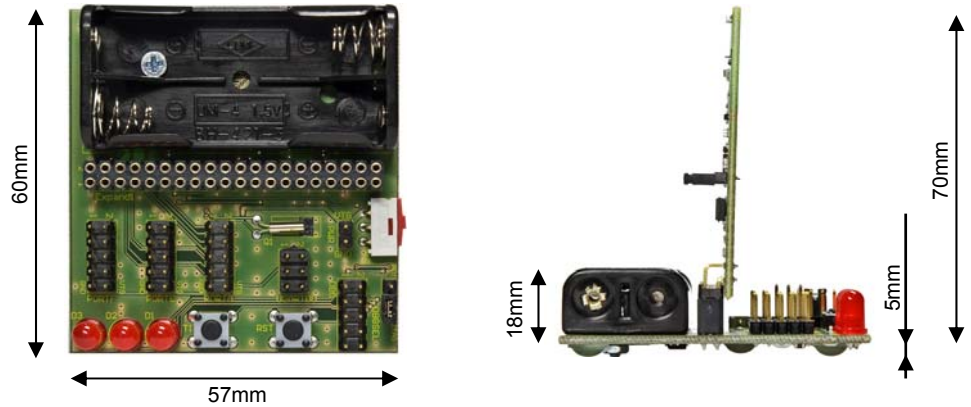

**Table 4-1.** REB-CBB mechanical dimensions.

Dimension	Value
Width x	57mm
Width y	60mm
PCB standoff height	5mm
Height without REB	18mm
Height with REB231ED plugged in	70mm

## 5 Functional description

The Atmel REB-CBB carries a high-performance Atmel AVR XMEGA microcontroller, which connects to the radio extender board and various peripheral units (see [Figure 5-1](#)). It is powered by two AAA batteries or optionally by applying an external voltage source.

**Figure 5-1.** REB-CBB block diagram.

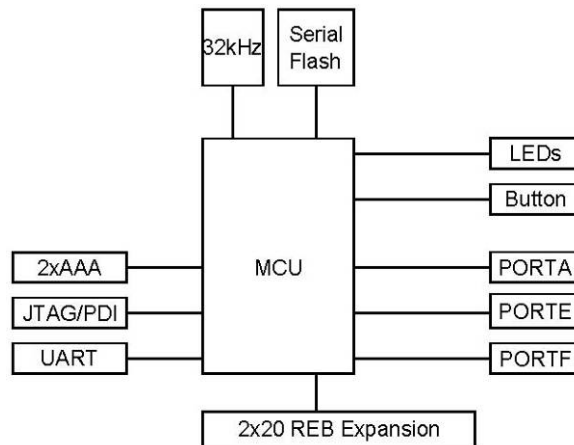

### 5.1 Power supply

The board is powered by two AAA batteries. The power switch, SW1, disconnects batteries from the entire board. External power is not routed through the power switch.

For debugging and test purposes, power can also be supplied at pin header PWR.

**NOTE**

There is no protection against over-voltage.

Take care when applying power from an external source. Refer to [Section 7.1](#) for allowable input voltage range. Exceeding these limits may destroy the board. In addition, avoid applying reverse currents into batteries by switching SW1 to the off position, or by removing the batteries when using external power.

**Figure 5-2.** Power supply of the REB-CBB.

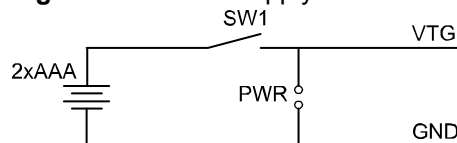

### 5.2 Microcontroller

The Atmel XMEGA A3 is a family of low-power, high-performance, and peripheral-rich CMOS 8/16-bit microcontrollers based on the AVR enhanced RISC architecture. By executing powerful instructions in a single clock cycle, the Atmel XMEGA A3 achieves throughputs of up to 1 million instructions per second (MIPS) per MHz, allowing the system designer to optimize power consumption versus processing



speed. A detailed description of the Atmel ATxmega256A3 can be found in the datasheet [2].

**Table 5-1.** ATxmega256A3 ordering information.

Ordering code	Flash	EEPROM	SRAM	Speed [MHz]	Power supply	Package	Temperature
ATxmega256A3-AU	256KB + 8KB	4KB	16KB	32	1.6V – 3.6V	64A TQFP-64	-40°C – 85°C

## 5.3 Clock sources

The XMEGA has a flexible clock system, supporting a large number of clock sources. It incorporates both calibrated integrated oscillators and external crystal oscillators, and resonators. The Atmel AVR XMEGA family allows dynamic switching between the clock sources.

Internal clock sources are:

- 32kHz RC oscillator
- 2MHz RC oscillator
- 32MHz RC oscillator

The 2/32MHz oscillators can be calibrated using an automatic runtime calibration feature.

In addition to the internal clock sources, two different external clock sources are supported:

- The 32.768kHz crystal oscillator connected to TOSC1/2 delivers an accurate clock for a real-time counter, or optionally a system clock for XMEGA
- The transceiver clock, CLKM, can be used as an accurate clock derived from the 16MHz radio transceiver oscillator. This signal is routed to the controller input at pin 59 (PR1)

A crystal oscillator failure monitor can be enabled to issue a non-maskable interrupt and switch to internal oscillator if the external oscillator fails.

A high frequency phase-locked loop (PLL) and a clock prescaler are available to generate a wide range of clock frequencies. After reset, the device will always start up running from the 2MHz internal oscillator. During normal operation, the system clock source and prescalers can be changed from software at any time.

### 5.3.1 32kHz crystal oscillator

The 32.768kHz crystal oscillator is a low-power oscillator using an external crystal. The oscillator can be used as a clock source for the system clock, the RTCs, and as a reference clock for the PLL.

A low-power mode with reduced voltage swing on TOSC2 is available.

The 32kHz crystal is connected to PE6,7.

NOTE

These pins cannot be used as general purpose I/O on header PORTE.

**Figure 5-3.** 32kHz crystal connection.

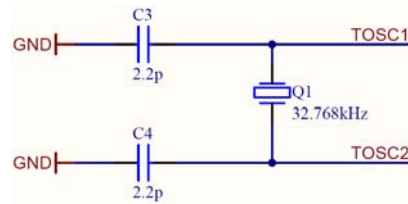

**Table 5-2.** 32kHz crystal connection.

ATxmega256A3	32kHz crystal
PE6 (42)	TOSC2
PE7 (43)	TOSC1

### 5.3.2 Transceiver clock (CLKM)

To make use of the transceiver clock, CLKM, an Atmel REB has to be connected to the Atmel REB-CBB and the radio transceiver has to be set up properly on the REB. The transceiver delivers a 1MHz clock frequency after power on. Although it is possible to set the clock frequency up to 16MHz by writing to the transceiver register, no frequencies above 1MHz should be used to drive the microcontroller. This is because the signal is filtered directly at the output pin for EMI suppression to ensure the best RF performance of the REB. To reach a system clock frequency higher than 1MHz, the Atmel XMEGA internal PLL should be used.

**Table 5-3.** Transceiver clock (CLKM) connection.

ATxmega256A3	Clock source
PD0 (26)	CLKM 1MHz

The REB has to be modified to deliver the CLKM signal to PD0. Therefore, the appropriate solder jumper (0Ω resistor) has to be mounted. Designators of the 0Ω resistor are different for REB variants, and they are listed in [Table 5-4](#).

**Table 5-4.** REB specific CLKM solder jumpers.

REB name	Solder jumper designator (REB)
REB230	R02
REB231	R02
REB231ED	R3
REB212	R3
REB232ED	R3
REB231FE2	R3

### 5.4 User I/O

For simple applications and debugging purposes, or just to deliver status information, a basic user interface is provided directly on the board consisting of three LEDs and a pushbutton.

**Figure 5-4. User I/Os.**

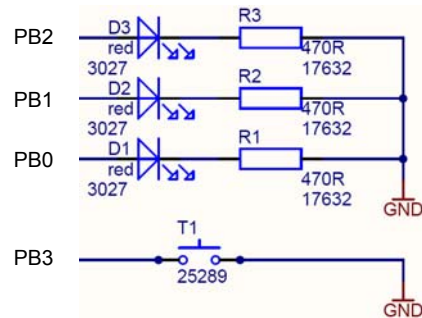

The LEDs are connected to PB0..2 for active-high operation. The key will pull PB3 to GND. The key is intended to be used in combination with the internal pull-up resistor.

**Table 5-5. LED/Button connection.**

ATxmega256A3	I/O
PB0 (6)	D1
PB1 (7)	D2
PB2 (8)	D3
PB3 (9)	T1

To get full accessibility to all I/O pins of the Atmel ATxmega256A3, three 8-bit ports are routed to 10-pin headers. Each header provides additional pins for VTG and GND. Figure 5-5 shows the pin-out for a single port.

**Figure 5-5. General pin-out of I/O port headers.**

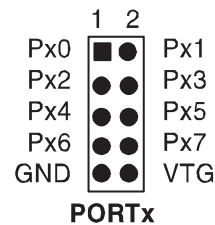

**Table 5-6. PORTA header connection.**

Header PORTA	ATxmega256A3
1	PA0 (62)
2	PA1 (63)
3	PA2 (64)
4	PA3 (1)
5	PA4 (2)
6	PA5 (3)
7	PA6 (4)
8	PA7 (5)
9	GND
10	VTG



**Table 5-7.** PORTE header connection.

Header PORTE	ATxmega256A3
1	PE0 (62)
2	PE1 (63)
3	PE2 (64)
4	PE3 (1)
5	PE4 (2)
6	PE5 (3)
7	
8	
9	GND
10	VTG

**Table 5-8.** PORTF header connection.

Header PORTF	ATxmega256A3
1	PF0 (62)
2	PF1 (63)
3	PF2 (64)
4	PF3 (1)
5	PF4 (2)
6	PF5 (3)
7	PF6 (4)
8	PF7 (5)
9	GND
10	VTG

## 5.5 Serial flash

The Atmel REB-CBB is populated with a 4MBit serial flash device (Atmel AT25DF041A) for persistent data storage. It is capable of storing one complete firmware image of the Atmel ATxmega256A3, which makes it suitable for over-the-air upgrades (OTA). It is connected to SPID PD4..7.

**Table 5-9.** Serial flash connection.

ATxmega256A3	AT25DF041A
PD4 (30)	#CS
PD5 (31)	SI
PD6 (32)	SO
PD7 (33)	SCK

The AT25DF041A supports SPI frequencies of up to 50MHz at supply voltages down to 2.3V. When operating the board below 2.3V, the serial flash cannot be accessed, see datasheet [\[3\]](#) for more information.

**Table 5-10. AT25DF041A ordering information.**

Ordering code	Flash	Maximum frequency	Power supply	Package	Temperature
AT25DF041A-SSHF-T	4MBit	50MHz	2.3V – 3.6V	8S1 SOP-8	-40°C – 85°C

## 5.6 UART/USART

The signal lines for asynchronous serial operation, using USARTD0, of the Atmel ATxmega256A3 are connected to header USARTD0. In addition, the MCU reset line is connected to pin 5 of this header. This can be used to work with a serial boot loader. No level conversion is done; therefore, an external RS232/TTL conversion circuit is required.

The header pin-out mates with the available RS232/TTL converter (art. no. de28560).

**Table 5-11. Connection of USARTD0.**

ATxmega256A3	Header USARTD0	Description
PD2 (28)	RxD (4)	Asynchronous serial in
PD3 (29)	TxD (1)	Asynchronous serial out
RESET (57)	RESET (5)	MCU reset
	VTG (2)	Operating voltage
	GND (6)	Ground

Synchronous operation is not supported at this connector since the clock line at PD1(27) is already in use to control the TXCW pin when the Atmel AT86RF230 is connected.

However, in addition all interface pins for USARTE0 and USARTEF0 are accessible for all operating modes including SPI.

PC connectivity can be easily achieved by using either a RS232 level shifter cable [4] as shown in Figure 5-6 or by using a serial to USB level shifter stick [5] as shown in Figure 5-7. These adapter cables are provided with Atmel kit deliveries as listed in Table 3-1.

**Figure 5-6. RS232 level shifter cable.**

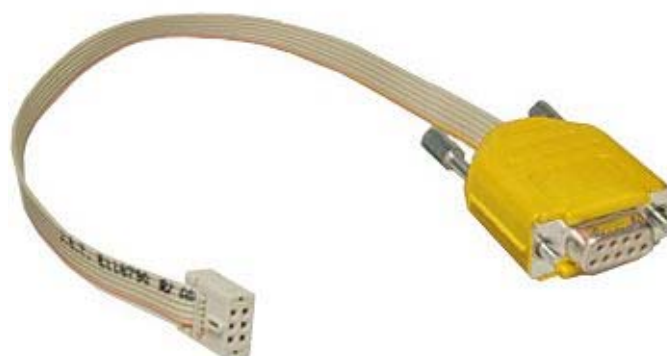
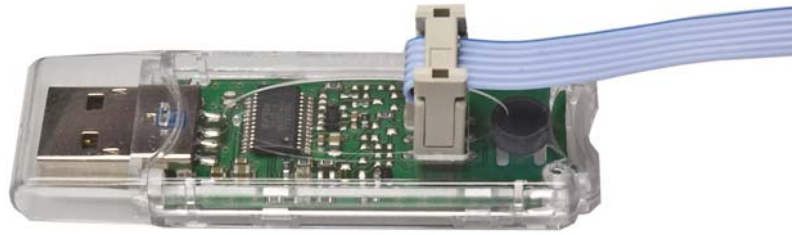

Figure 5-7. USB level shifter stick.



## 6 Programming

On the Atmel ATxmega256A3, both programming and debugging can be done through two physical interfaces.

The primary interface is the program and debug interface (PDI). This is a two-pin interface using the reset pin for the clock input (PDI\_CLK) and the dedicated test pin for data input and output (PDI\_DATA).

Programming and debugging can also be done through the four-pin JTAG interface. The JTAG interface is IEEE 1149.1 standard compliant and supports boundary scan. Any external programmer or on-chip debugger/emulator can be directly connected to these interfaces, and no external components are required.

The Atmel REB-CBB provides a 10-pin header to connect the Atmel AVR JTAGICE mkII probe. This connection can be used for both protocols, JTAG and PDI.

**Figure 6-1.** Connection between JTAGICE mkII and REB-CBB.

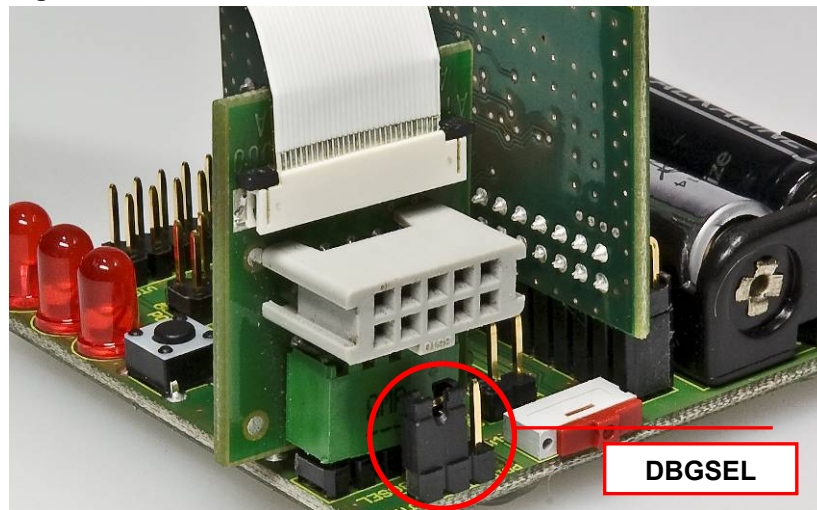

To select between one of the protocols, the jumper DBGSEL has to be set to the appropriate position. It routes test data input (signal TDI) to either TDI of the JTAG interface or PDI of the Atmel proprietary PDI interface.

**Figure 6-2.** Debug interface.

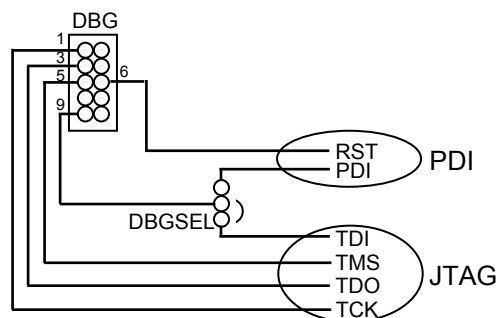

NOTE

Atmel AVR JTAGICE mkII units with hardware revision 0 do not have PDI capabilities.

**Table 6-1.** Connection of header DBG.

<b>DBG Connector</b>	<b>DBGSEL=JTAG</b>	<b>DBGSEL=PDI</b>
TMS (5)	PB4 (10)	PB4 (10) unused
TDI (9)	PB5 (11)	PDI (56)
TCK (1)	PB6 (12)	PB6 (12) unused
TDO (3)	PB7 (13)	PB7 (13) unused
nSRST (6)	RESET (57)	RESET (57)



## 7 Electrical characteristics

### 7.1 Absolute maximum ratings

Stresses beyond those listed under “Absolute maximum ratings” may cause permanent damage to the board. This is a stress rating only and functional operation of the device at these or any other conditions beyond those indicated in the operational sections of this manual are not implied. Exposure to absolute maximum rating conditions for extended periods may affect device reliability. For more details about these parameters, refer to individual datasheets of the components used.

**Table 7-1.** Absolute maximum ratings.

No.	Parameter	Condition	Minimum	Typical	Maximum	Unit
7.1.1	Storage temperature range		-40		+85	°C
7.1.2	Relative humidity	Non-condensing			90	% r.H.
7.1.3	Supply voltage		-0.3		+3.6	V
7.1.4	EXT I/O pin voltage		-0.3		$V_{CC} + 0.3$	V
7.1.5	Supply current from batteries	Sum over all power pins			-0.5	A
7.1.6	Battery charge current <sup>(1)</sup>				0	mA

Note: 1. Keep power switch off or remove batteries from REB-CBB when external power is supplied.

### 7.2 Recommended operating range

**Table 7-2.** Recommended operating range.

No.	Parameter	Condition	Minimum	Typical	Maximum	Unit
7.2.1	Temperature range		-10		+60	°C
7.2.2	Supply voltage ( $V_{CC}$ )	Plain REB-CBB	1.6	3.0	3.6	V
7.2.3		REB plugged on REB-CBB	1.8	3.0	3.6	V
7.2.4		Serial flash access in usage	2.3	3.0	3.6	V

### 7.3 Current consumption

Test conditions (unless otherwise stated):

$$V_{DD} = 3.0V, T_{OP} = 25^{\circ}C$$

[Table 7-3](#) lists current consumption values for typical scenarios of a complete system composed of Atmel REB-CBB and Atmel REB231. The Z-diode has been removed as described below.

**Table 7-3.** Current consumption of REB-CBB populated with REB231.

No.	Parameter	Condition	Minimum	Typical	Maximum	Unit
7.3.1	Supply current	MCU @ power-down, transceiver in state SLEEP, serial flash in Deep-Sleep		17		$\mu A$
7.3.2	Supply current	MCU @ 2MHz, transceiver in state TRX_OFF		3		mA
7.3.3	Supply current	MCU @ 16MHz (int. RC 32MHz), transceiver in state TRX_OFF		15		mA

No.	Parameter	Condition	Minimum	Typical	Maximum	Unit
7.3.4	Supply current	MCU @ 16MHz (int. RC 32MHz), transceiver in state RX_ON		28		mA
7.3.5	Supply current	MCU @ 16MHz (int. RC 32MHz), transceiver in state BUSY_TX		26		mA

For current consumption measurements, please regard the Z-diode mounted on the REB. It prevents applying overvoltage stress to the radio transceiver circuit as well as protection against reverse polarity.

**Figure 7-1.** REB overvoltage protection mechanism.

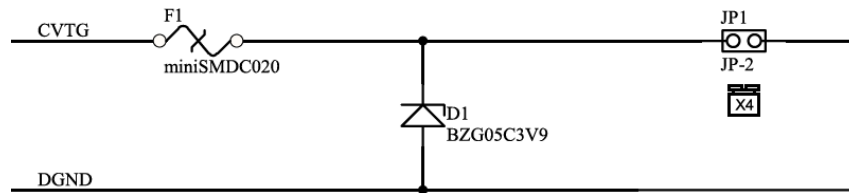

The Z-diode draws approximately 6mA at 3.0V (type: BZG05-C3V9), which should be considered in overall current consumption. The Z-diode shall be removed for low-power designs or in case of current measurements.



## 8 Abbreviations

CLKM	-	Transceiver clock
DBG	-	Debug (interface)
EMI	-	Electromagnetic interference
JTAG	-	Joint Test Action Group
MCU	-	Microcontroller Unit
OTA	-	Over-the-air (upgrades)
PDI	-	Program/debug interface
PLL	-	Phase-locked loop
REB	-	Radio extender board
REB-CBB	-	REB controller base board
RTC	-	Real time counter
SPI	-	Serial peripheral interface
UART	-	Universal asynchronous receiver/transmitter
USART	-	Universal synchronous/asynchronous receiver/transmitter



## Appendix A - PCB design data

### A.1 Schematic

Figure 8-1. Schematic.

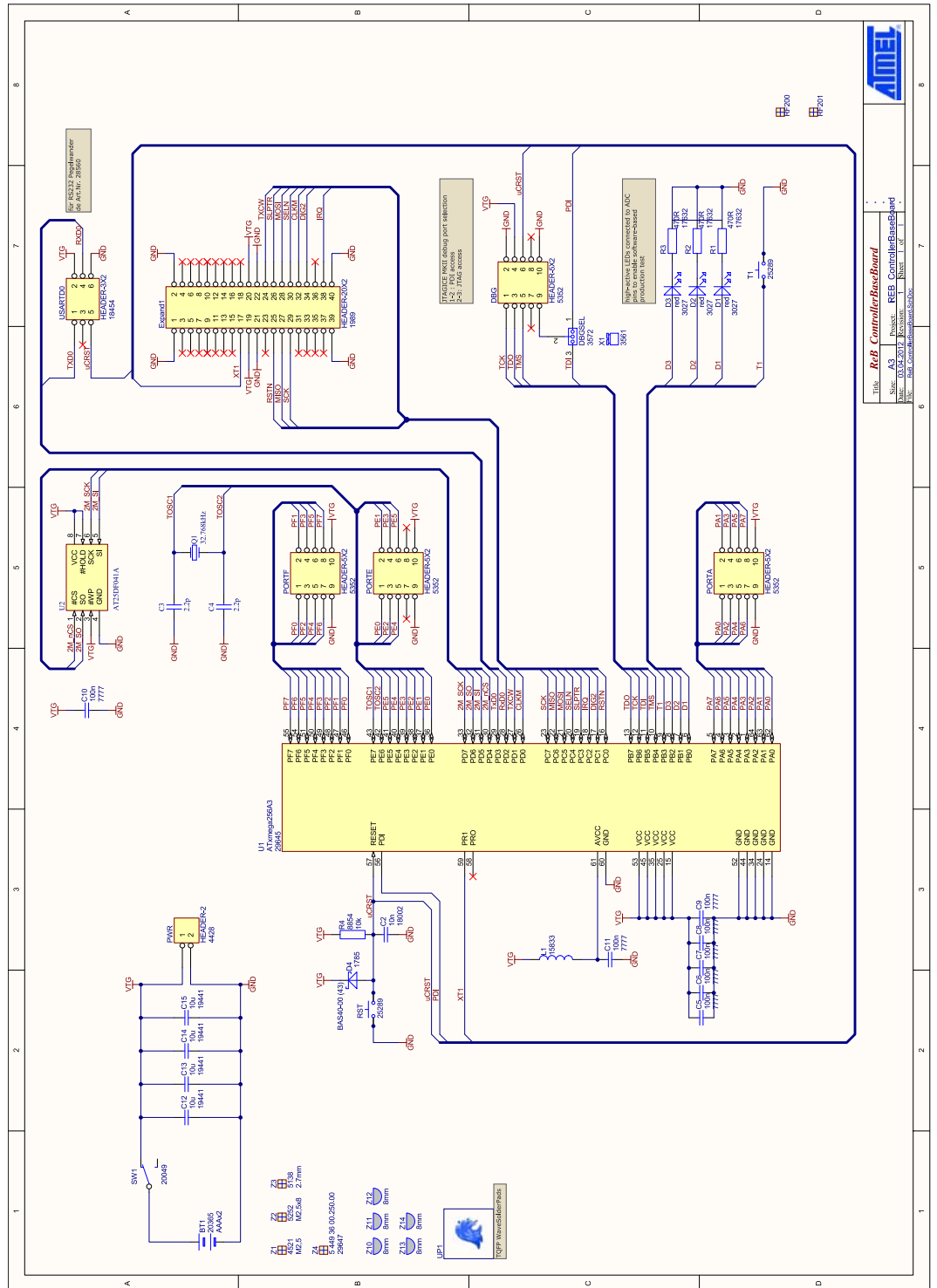

## A.2 Assembly drawing

**Figure 8-2. Assembly top.**

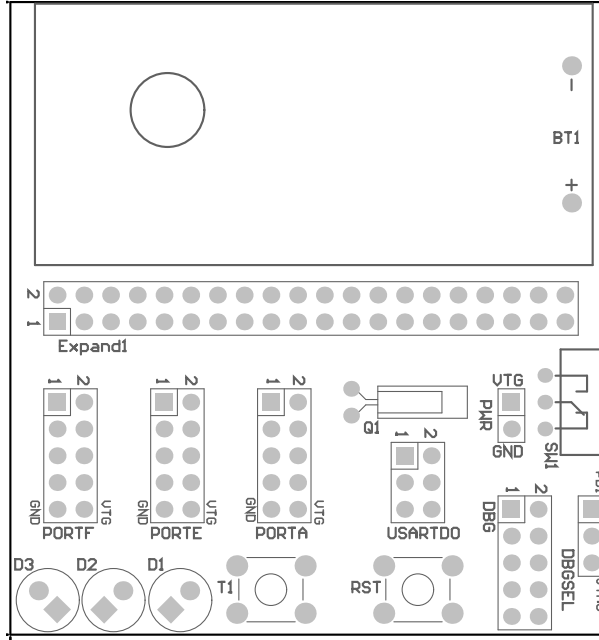

**Figure 8-3. Assembly bottom.**

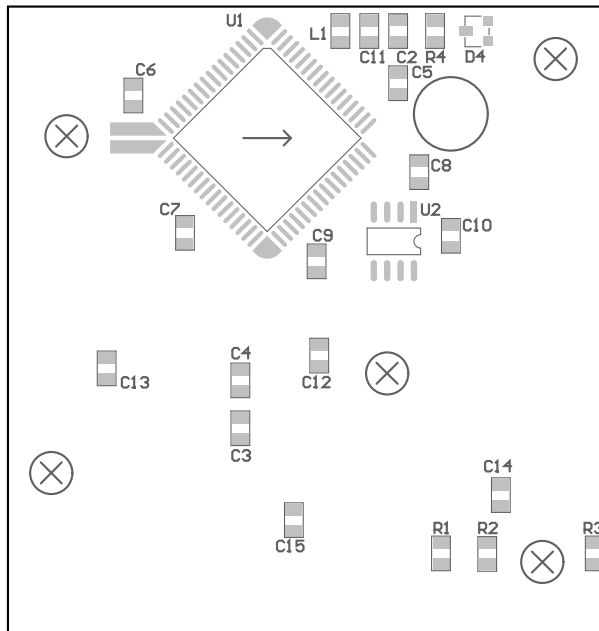

## A.3 Bill of materials

Designator	Description	Value	Manufacturer	Part number	Comment
BT1	Battery holder	2 × AAA		BH 421-3	
C2	Capacitor	10nF			
C3, C4	Capacitor	2.2pF			
C5, C6, C7, C8, C9, C10, C11	Capacitor	100nF			
C12, C13, C14, C15	Capacitor	10μF			
D1, D2, D3	LED	red		WU-2-69HD/LC	
D4	Schottky diode		Vishay	BAS40-00 (43)	
DBG, PORTA, PORTE, PORTF	Header 5 × 2 100mil				
DBGSEL	Header 3 × 1 100mil				
Expand1	Header female 20 × 2 100mil				
L1	Inductor				
PWR	Header 2 × 1 100mil				
Q1	Quartz	32.768kHz			
R1, R2, R3	Resistor	470Ω			
R4	Resistor	10kΩ			
RST, T1	Pushbutton				
SW1	Switch, single-pole				
U1	8/16-bit AVR XMEGA microcontroller	ATxmega256A3	Atmel	ATxmega256A3-MH	
U2	4Mb SPI serial flash memory	AT25DF041A	Atmel	AT25DF041A	
USARTD0	Header 3 × 2 100mil				
X1	Jumper 100mil				
Z1	Nut	M2.5			
Z2	Countersink screw	M2.5 × 8		DIN965/4.8/gal ZN	
Z3	Nylon washer M2.5	2.7mm		DIN125	
Z10, Z11, Z12, Z13, Z14	Rubber foot 8.0 × 2.5mm	8mm			



## EVALUATION BOARD/KIT IMPORTANT NOTICE

This evaluation board/kit is intended for use for **FURTHER ENGINEERING, DEVELOPMENT, DEMONSTRATION, OR EVALUATION PURPOSES ONLY**. It is not a finished product and may not (yet) comply with some or any technical or legal requirements that are applicable to finished products, including, without limitation, directives regarding electromagnetic compatibility, recycling (WEEE), FCC, CE or UL (except as may be otherwise noted on the board/kit). Atmel supplied this board/kit "AS IS," without any warranties, with all faults, at the buyer's and further users' sole risk. The user assumes all responsibility and liability for proper and safe handling of the goods. Further, the user indemnifies Atmel from all claims arising from the handling or use of the goods. Due to the open construction of the product, it is the user's responsibility to take any and all appropriate precautions with regard to electrostatic discharge and any other technical or legal concerns.

EXCEPT TO THE EXTENT OF THE INDEMNITY SET FORTH ABOVE, NEITHER USER NOR ATMEL SHALL BE LIABLE TO EACH OTHER FOR ANY INDIRECT, SPECIAL, INCIDENTAL, OR CONSEQUENTIAL DAMAGES.

No license is granted under any patent right or other intellectual property right of Atmel covering or relating to any machine, process, or combination in which such Atmel products or services might be or are used.

Mailing Address: Atmel Corporation, 2325 Orchard Parkway, San Jose, CA 95131

Copyright © 2012, Atmel Corporation

**References**

[1]	IEEE Std 802.15.4™-2006: Wireless Medium Access Control (MAC) and Physical Layer (PHY) Specifications for Low-Rate Wireless Personal Area Networks (LR-WPANs)
[2]	Atmel ATxmega256A3; High-performance, Low-power 8/16-bit AVR XMEGA Microcontroller; datasheet; rev. 8068P – 02/10; Atmel Corporation
[3]	Atmel AT25DF041A; 4-Megabit 2.3-volt or 2.7-volt Minimum SPI Serial Flash Memory; datasheet; revision D – September 2008; Atmel Corporation
[4]	RS232 Level Shifter; datasheet; 02/11; Dresden Elektronik Ingenieurtechnik gmbh
[5]	USB Level Shifter Stick Basic; datasheet; 03/12; Dresden Elektronik Ingenieurtechnik gmbh

**Revision history REB Controller Base board**

<b>Version</b>	<b>Description</b>
A09-1258/01	Initial release
A09-1258/02	Not released
A09-1258/03	Not released
A09-1258/04	Replacement of U2 Serial Data Flash (AT25DF021-SSHF by AT25DF041-SSHF), crystal Q1 and load capacitors C3, C4



## Table of contents

<b>Features</b> .....	<b>1</b>
<b>1 Introduction</b> .....	<b>1</b>
<b>2 Disclaimer</b> .....	<b>2</b>
<b>3 Overview</b> .....	<b>2</b>
<b>4 Mechanical description</b> .....	<b>4</b>
<b>5 Functional description</b> .....	<b>5</b>
5.1 Power supply .....	5
5.2 Microcontroller .....	5
5.3 Clock sources .....	6
5.3.1 32kHz crystal oscillator .....	6
5.3.2 Transceiver clock (CLKM) .....	7
5.4 User I/O .....	7
5.5 Serial flash .....	9
5.6 UART/USART .....	10
<b>6 Programming</b> .....	<b>12</b>
<b>7 Electrical characteristics</b> .....	<b>14</b>
7.1 Absolute maximum ratings .....	14
7.2 Recommended operating range .....	14
7.3 Current consumption .....	14
<b>8 Abbreviations</b> .....	<b>16</b>
A.1 Schematic .....	17
A.2 Assembly drawing .....	18
A.3 Bill of materials .....	19
<b>EVALUATION BOARD/KIT IMPORTANT NOTICE</b> .....	<b>20</b>
<b>References</b> .....	<b>21</b>
<b>Revision history REB Controller Base board</b> .....	<b>21</b>
<b>Table of contents</b> .....	<b>22</b>



**Atmel Corporation**  
2325 Orchard Parkway  
San Jose, CA 95131  
USA  
**Tel:** (+1)(408) 441-0311  
**Fax:** (+1)(408) 487-2600  
[www.atmel.com](http://www.atmel.com)

**Atmel Asia Limited**  
Unit 01-5 & 16, 19F  
BEA Tower, Millennium City 5  
418 Kwun Tong Road  
Kwun Tong, Kowloon  
HONG KONG  
**Tel:** (+852) 2245-6100  
**Fax:** (+852) 2722-1369

**Atmel Munich GmbH**  
Business Campus  
Parkring 4  
D-85748 Garching b.  
Munich  
GERMANY  
**Tel:** (+49) 89-31970-0  
**Fax:** (+49) 89-3194621

**Atmel Japan**  
16F, Shin Osaki Kangyo Bldg.  
1-6-4 Osaki Shinagawa-ku  
Tokyo 104-0032  
JAPAN  
**Tel:** (+81) 3-6417-0300  
**Fax:** (+81) 3-6417-0370

© 2012 Atmel Corporation. All rights reserved.

Atmel®, Atmel logo and combinations thereof, AVR®, XMEGA®, and others are registered trademarks or trademarks of Atmel Corporation or its subsidiaries. Other terms and product names may be trademarks of others.

**Disclaimer:** The information in this document is provided in connection with Atmel products. No license, express or implied, by estoppel or otherwise, to any intellectual property right is granted by this document or in connection with the sale of Atmel products. **EXCEPT AS SET FORTH IN THE ATMEL TERMS AND CONDITIONS OF SALES LOCATED ON THE ATMEL WEBSITE, ATMEL ASSUMES NO LIABILITY WHATSOEVER AND DISCLAIMS ANY EXPRESS, IMPLIED OR STATUTORY WARRANTY RELATING TO ITS PRODUCTS INCLUDING, BUT NOT LIMITED TO, THE IMPLIED WARRANTY OF MERCHANTABILITY, FITNESS FOR A PARTICULAR PURPOSE, OR NON-INFRINGEMENT. IN NO EVENT SHALL ATMEL BE LIABLE FOR ANY DIRECT, INDIRECT, CONSEQUENTIAL, PUNITIVE, SPECIAL OR INCIDENTAL DAMAGES (INCLUDING, WITHOUT LIMITATION, DAMAGES FOR LOSS AND PROFITS, BUSINESS INTERRUPTION, OR LOSS OF INFORMATION) ARISING OUT OF THE USE OR INABILITY TO USE THIS DOCUMENT, EVEN IF ATMEL HAS BEEN ADVISED OF THE POSSIBILITY OF SUCH DAMAGES.** Atmel makes no representations or warranties with respect to the accuracy or completeness of the contents of this document and reserves the right to make changes to specifications and product descriptions at any time without notice. Atmel does not make any commitment to update the information contained herein. Unless specifically provided otherwise, Atmel products are not suitable for, and shall not be used in, automotive applications. Atmel products are not intended, authorized, or warranted for use as components in applications intended to support or sustain life.

# Mouser Electronics

Authorized Distributor

Click to View Pricing, Inventory, Delivery & Lifecycle Information:

[Microchip:](#)

[ATREB231FE2-EK](#) [ATREB232ED-EK](#)





## Стандарт Электрон Связь

Мы молодая и активно развивающаяся компания в области поставок электронных компонентов. Мы поставляем электронные компоненты отечественного и импортного производства напрямую от производителей и с крупнейших складов мира.

Благодаря сотрудничеству с мировыми поставщиками мы осуществляем комплексные и плановые поставки широчайшего спектра электронных компонентов.

Собственная эффективная логистика и склад в обеспечивает надежную поставку продукции в точно указанные сроки по всей России.

Мы осуществляем техническую поддержку нашим клиентам и предпродажную проверку качества продукции. На все поставляемые продукты мы предоставляем гарантию .

Осуществляем поставки продукции под контролем ВП МО РФ на предприятия военно-промышленного комплекса России , а также работаем в рамках 275 ФЗ с открытием отдельных счетов в уполномоченном банке. Система менеджмента качества компании соответствует требованиям ГОСТ ISO 9001.

Минимальные сроки поставки, гибкие цены, неограниченный ассортимент и индивидуальный подход к клиентам являются основой для выстраивания долгосрочного и эффективного сотрудничества с предприятиями радиоэлектронной промышленности, предприятиями ВПК и научно-исследовательскими институтами России.

С нами вы становитесь еще успешнее!

### Наши контакты:

**Телефон:** +7 812 627 14 35

**Электронная почта:** [sales@st-electron.ru](mailto:sales@st-electron.ru)

**Адрес:** 198099, Санкт-Петербург,  
Промышленная ул, дом № 19, литера Н,  
помещение 100-Н Офис 331