

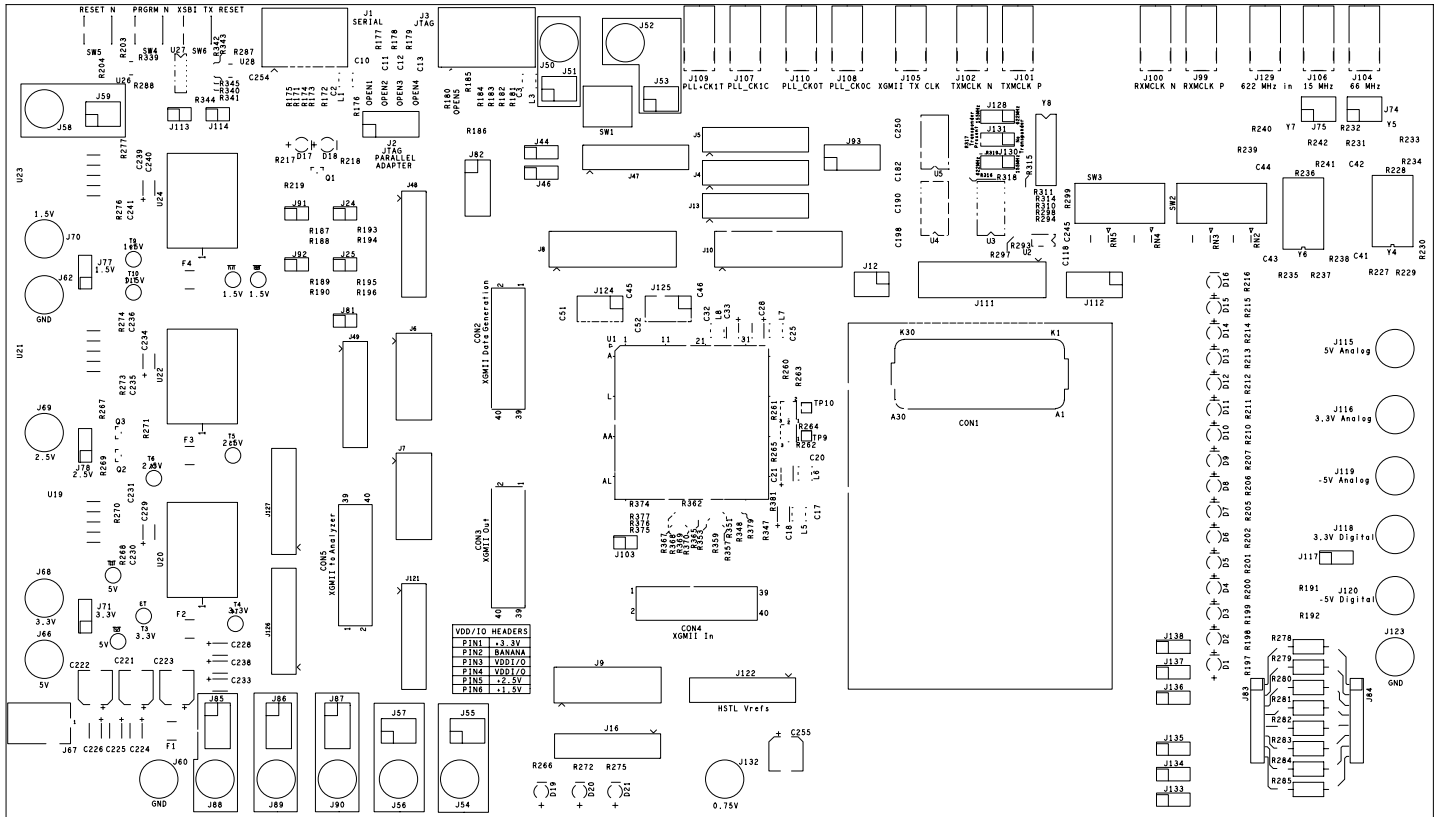

ORLI10G Evaluation Board User Manual

SECTION	PAGE
LAYOUT OF ORLI10G BOARD:	3
CONNECTORS AND JUMPERS J1 TO J127:	4
CONNECTORS CON1 TO CON5:	18
ADJUSTABLE RESISTORS:	22

Layout of ORLI10G board:



Connectors and jumpers J1 to J127:

J1

Schematic page 2

A 7-pin serial connector used for configuration. An arrow, as well as the company's logo indicates pin one.

Serial Connector	
Pin 1	VDD
Pin 2	CCLK
Pin 3	D0
Pin 4	DONE
Pin 5	PROG
Pin 6	NC
Pin 7	GND

J2

Schematic page 2

Ten-pin header (2X5) used with an adapter to program the device via a parallel cable. **J2** is numbered as a standard header. Looking at it from above, pin one would be the top left pin. Pin two is to the right of pin one. Pin three is under pin one. Pin four is to the right of pin three, etc.

JTAG Parallel Adapter			
Pin 1	VDD	Pin 2	DONE
Pin 3	PRGRM_N	Pin 4	TDI
Pin 5	RESET_N	Pin 6	TMS
Pin 7	INIT_N	Pin 8	TCK
Pin 9	GND	Pin 10	RD_DATA_TDO

J3

Schematic page 2

J3 is an 8-pin JTAG connector. It is physically similar to **J1**; an arrow indicates pin 1.

JTAG Connector	
Pin 1	VDD
Pin 2	TDI
Pin 3	TMS
Pin 4	TCK
Pin 5	TDO
Pin 6	RD_CFG
Pin 7	INIT_N
Pin 8	GND

J4

Schematic page 2

This is a *standard* header. Pin one is at the top left. Pin numbers increment from left to right. The pins on this header correspond to dip switches. **J4** is in line with **J13**. They can be connected via a ribbon cable to provide input for the ORLI10G.

J4			
Pin 1	SW3.1	Pin 2	SW3.2
Pin 3	SW3.3	Pin 4	SW3.4
Pin 5	SW3.5	Pin 6	SW3.6
Pin 7	SW3.7	Pin 8	SW3.8
Pin 9	NC	Pin 10	NC
Pin 11	SW2.8	Pin 12	SW2.7
Pin 13	SW2.6	Pin 14	SW2.5
Pin 15	SW2.4	Pin 16	SW2.3
Pin 17	SW2.2	Pin 18	SW2.1
Pin 19	NC	Pin 20	NC

J5

Schematic page 4

This is a standard header as described above. This header connects to LEDs. When a jumper cable is used, output from the ORLI10G can drive these LEDs to display a pattern. The connections are:

J5			
Pin 1	red LED	Pin 2	red LED
Pin 3	red LED	Pin 4	red LED
Pin 5	yellow LED	Pin 6	yellow LED
Pin 7	yellow LED	Pin 8	yellow LED
Pin 9	N.C.	Pin 10	N.C.
Pin 11	green LED	Pin 12	green LED
Pin 13	green LED	Pin 14	green LED
Pin 15	red LED	Pin 16	red LED
Pin 17	red LED	Pin 18	red LED
Pin 19	N.C.	Pin 20	N.C.

J5 is positioned in line with **J13**. They can be connected with a ribbon cable to provide a visual output for the ORLI10G.

J6-J7

Schematic page 7

These are 3 by 8 headers that provide differential output from the ORLI10G. The first column (pins 1, 4, 7, 10, etc.) connect to the true side of the pair. Ground is connected to the middle column (pins 2, 5, 8, 11, etc.). And, the third column (pins 3, 6, 9, 12, etc.) are connected to the complement side of the pair.

J6					
Pin 1	PL5A	Pin 2	GND	Pin 3	PL5B
Pin 4	PL6C	Pin 5	GND	Pin 6	PL6D
Pin 7	PL9C	Pin 8	GND	Pin 9	PL9D
Pin 10	PL12A	Pin 11	GND	Pin 12	PL12B
Pin 13	PL12C	Pin 14	GND	Pin 15	PL12D
Pin 16	PL13A	Pin 17	GND	Pin 18	PL13B
Pin 19	PL18A	Pin 20	GND	Pin 21	PL18B
Pin 22	PL19A	Pin 23	GND	Pin 24	PL19B

J7					
Pin 1	PL20A	Pin 2	GND	Pin 3	PL20B
Pin 4	PL21A	Pin 5	GND	Pin 6	PL21B
Pin 7	PL27A	Pin 8	GND	Pin 9	PL27B
Pin 10	PL34A	Pin 11	GND	Pin 12	PL34B
Pin 13	PL35A	Pin 14	GND	Pin 15	PL35B
Pin 16	PL39A	Pin 17	GND	Pin 18	PL39B
Pin 19	PL4C	Pin 20	GND	Pin 21	PL4D
Pin 22	NC	Pin 23	GND	Pin 24	NC

J8 and J10

Schematic page 7

These are 3 by 12 headers that provide differential output from the ORLI10G. The first column (pins 1, 4, 7, 10, etc.) connect to the true side of the pair. Ground is connected to the middle column (pins 2, 5, 8, 11, etc.). And, the third column (pins 3, 6, 9, 12, etc.) are connected to the complement side of the pair.

J8					
Pin 1	NC	Pin 2	GND	Pin 3	NC
Pin 4	PT2A	Pin 5	GND	Pin 6	PT2B
Pin 7	PT3A	Pin 8	GND	Pin 9	PT3B
Pin 10	PT4A	Pin 11	GND	Pin 12	PT4B
Pin 13	PT5C	Pin 14	GND	Pin 15	PT5D
Pin 16	PT6C	Pin 17	GND	Pin 18	PT6D
Pin 19	PT7C	Pin 20	GND	Pin 21	PT7D
Pin 22	PT27A	Pin 23	GND	Pin 24	PT27B
Pin 25	PT28A	Pin 26	GND	Pin 27	PT28B
Pin 28	PT28C	Pin 29	GND	Pin 30	PT28D
Pin 31	PT29A	Pin 32	GND	Pin 33	PT29B
Pin 34	PT29C	Pin 35	GND	Pin 36	PT29D

J10					
Pin 1	PT10C	Pin 2	GND	Pin 3	PT10D
Pin 4	PT12A	Pin 5	GND	Pin 6	PT12B
Pin 7	PT13C	Pin 8	GND	Pin 9	PT13D
Pin 10	PT15C	Pin 11	GND	Pin 12	PT15D
Pin 13	PT18A	Pin 14	GND	Pin 15	PT18B
Pin 16	PT19A	Pin 17	GND	Pin 18	PT19B
Pin 19	PT20C	Pin 20	GND	Pin 21	PT20D
Pin 22	PT21C	Pin 23	GND	Pin 24	PT21D
Pin 25	PT22C	Pin 26	GND	Pin 27	PT22D
Pin 28	PT23C	Pin 29	GND	Pin 30	PT23D
Pin 31	PT25C	Pin 32	GND	Pin 33	PT25D
Pin 34	PT26A	Pin 35	GND	Pin 36	PT26B

J9

Schematic page 7

These are 3 by 10 headers that provide differential output from the ORLI10G. The first column (pins 1, 4, 7, 10, etc.) connect to the true side of the pair. Ground is connected to the middle column (pins 2, 5, 8, 11, etc.). And, the third column (pins 3, 6, 9, 12, etc.) are connected to the complement side of the pair.

J9					
Pin 1	GND	Pin 2	GND	Pin 3	GND
Pin 4	PB2A	Pin 5	GND	Pin 6	PB2B
Pin 7	PB6A	Pin 8	GND	Pin 9	PB6B
Pin 10	PB11A	Pin 11	GND	Pin 12	PB11B
Pin 13	PB12A	Pin 14	GND	Pin 15	PB12B
Pin 16	PB13A	Pin 17	GND	Pin 18	PB13B
Pin 19	PB14A	Pin 20	GND	Pin 21	PB14B
Pin 22	PB30C	Pin 23	GND	Pin 24	PB30D
Pin 25	PB32C	Pin 26	GND	Pin 27	PB32D
Pin 28	GND	Pin 29	GND	Pin 30	GND

J11

Schematic page 10

SMA outputs the RX Clock from the XGMII interface.

J12

Schematic page 15

This is a standard 2 by 3 header that connects to the transponder to provide input.

J12			
Pin 1	LsTUNE0	Pin 2	GND
Pin 3	LsTUNE1	Pin 4	GND
Pin 5	LsTUNE2	Pin 6	GND

J13

Schematic page 6

This is a standard header that is physically located in line with **J5** and **J4**. By using a ribbon cable as a jumper, one can use output signals from **J13** to control the LEDs via **J5**, or control the input signals by the dip switches via **J4**. Only 16 pins are used for this purpose. The header can also be used as basic input/output.

J13			
Pin 1	PT3D	Pin 2	PT15A
Pin 3	PT5B	Pin 4	PT16A
Pin 5	PT6A	Pin 6	PT16C
Pin 7	PT9A	Pin 8	PT17A
Pin 9	PT9C	Pin 10	PT19D
Pin 11	PT10A	Pin 12	PT22A
Pin 13	PT11A	Pin 14	PT23A
Pin 15	PT13B	Pin 16	PT24A
Pin 17	PT14A	Pin 18	PT24D
Pin 19	PT14D	Pin 20	PT26D

J16

Schematic page 6

This is a standard header. By connecting this header to either **J5** or **J4** with a ribbon cable, one can use the jumpers to input signals to the ORLI10G or display the output of signals from the ORLI10G. Only the first 16 pins are used for this purpose. The header can also be used as basic input/output.

J16			
Pin 1	PB33C	Pin 2	PB9C
Pin 3	PB31D	Pin 4	PB9A
Pin 5	PB30A	Pin 6	PB8A
Pin 7	PB19C	Pin 8	PB7C
Pin 9	PB16A	Pin 10	PB7A
Pin 11	PB15C	Pin 12	PB6C
Pin 13	PB15A	Pin 14	PB4C
Pin 15	PB13C	Pin 16	PB4B
Pin 17	PB11C	Pin 18	PB3C
Pin 19	PB10A	Pin 20	PB3A

J24, J25

Schematic page 3

These headers are the chip select controls. The default is selected when no jumpers are present. **J24** controls CS1 and **J25** controls CS0_N.

J44, J46

Schematic page 13

These are three pin headers for the differential clock input. Pin one is complement, pin two is ground, and pin three is true.

J47-J49

Schematic page 18

These are 2X10 reference voltage headers. The extra pins are unconnected.

J47			
Pin 1	VREF_TC10	Pin 2	VREF_TC06
Pin 3	VREF_TC05	Pin 4	VREF_TC04
Pin 5	VREF_TC03	Pin 6	VREF_TC02
Pin 7	VREF_TC01	Pin 8	NC
Pin 9	NC	Pin 10	NC
Pin 11	NC	Pin 12	NC
Pin 13	NC	Pin 14	NC
Pin 15	NC	Pin 16	NC
Pin 17	NC	Pin 18	NC
Pin 19	NC	Pin 20	NC

J48			
Pin 1	VREF_TL01	Pin 2	VREF_TL02
Pin 3	VREF_TL03	Pin 4	VREF_TL04
Pin 5	VREF_TL05	Pin 6	VREF_TL06
Pin 7	VREF_TL07	Pin 8	VREF_TL08
Pin 9	VREF_TL09	Pin 10	VREF_TL10
Pin 11	NC	Pin 12	NC
Pin 13	NC	Pin 14	NC
Pin 15	NC	Pin 16	NC
Pin 17	NC	Pin 18	NC
Pin 19	NC	Pin 20	NC

J49			
Pin 1	VREF_CL1	Pin 2	VREF_CL2
Pin 3	VREF_CL3	Pin 4	VREF_CL4
Pin 5	VREF_CL5	Pin 6	VREF_CL6
Pin 7	VREF_CL7	Pin 8	VREF_CL8
Pin 9	NC	Pin 10	NC
Pin 11	NC	Pin 12	NC
Pin 13	NC	Pin 14	NC
Pin 15	NC	Pin 16	NC
Pin 17	NC	Pin 18	NC
Pin 19	NC	Pin 20	NC

J50, J52, J54, J56, J58

Schematic page 19

These banana jacks may be selected by connecting pin two with pin four on jumpers **J51**, **J53**, **J55**, **J57**, and **J59**, respectively, as input for the VddI/O.

J51, J53, J55, J57, J59

Schematic page 19

A 2 by 3 header that allows jumpers to select the input for the VddI/O voltage.

J51, J53, J55, J57, and J59			
Pin 1	3.3V	Pin 2	BANANA
Pin 3	VDDIO	Pin 4	VDDIO
Pin 5	2.5V	Pin 6	1.5V

J60, J62

Schematic page 20

These banana jacks are connected to the ground plane of the board.

J66

Schematic page 20

This banana jack connects to 5V and may be used to provide power to the board.

J67

Schematic page 20

This power jack takes 5V from the wall adapter.

J68-J70

Schematic page 21

These banana jacks may be selected to provide power to the board through relays controlled by jumpers **J71**, **J77** and **J78**. **J68** connects to 3.3V input, **J69** connects to 2.5V input, and **J70** connects to 1.5V input.

J71

Schematic page 21

This jumper selects if 3.3V is provided to the board by the regulator or from the banana jack.

J74

Schematic page 11

This jumper selects between a built in 66 MHz oscillator and an oscillator socket. Adding a jumper to pins 1 and 3 selects the socket. Pins 3 and 5 select the 66 MHz oscillator. The connector has a column of ground pins (pins 2, 4, and 6) so that the clock can be sent from the header via a twisted pair.

J74			
Pin 1	CLK SOCKET Y4	Pin 2	GND
Pin 3	SMA J104	Pin 4	GND
Pin 5	66MHz CLK Y5	Pin 6	GND

J75

Schematic page 11

This jumper selects between a built in 15 MHz oscillator and an oscillator socket. Adding a jumper to pins 1 and 3 selects the socket. Pins 3 and 5 select the 15 MHz oscillator. The connector has a column of ground pins (pins 2, 4, and 6) so that the clock can be sent from the header via a twisted pair.

J75			
Pin 1	CLK SOCKET Y6	Pin 2	GND
Pin 3	SMA J106	Pin 4	GND
Pin 5	15 MHz CLK Y7	Pin 6	GND

J77, J78

Schematic page 21

These jumpers select if the board is powered from the regulators or from the banana jacks. **J78** selects the 2.5V source, and **J77** selects the 1.5V source.

J81

Schematic page 3

This two-pin header is used to output the PTEMP signal from the ORLI10G. Pin 2 is connected to ground.

J82

Schematic page 2

J82 is a ten-pin header for additional dedicated signals from the ORLI10G. Unused pins are connected to ground.

J82			
Pin 1	GND	Pin 2	HDC
Pin 3	PCFG_MPI_IRQ	Pin 4	LDC_N
Pin 5	GND	Pin 6	DOUT
Pin 7	GND	Pin 8	RDY_BUSY_N_RCLK
Pin 9	GND	Pin 10	LVDS_R

J83, J84

Schematic page 22

These two 1 X 8 headers connect to the resistor sockets. The table shows the pin connections to the specific sockets.

J83	J84	Resistor
Pin 1	Pin 1	R278
Pin 2	Pin 2	R279
Pin 3	Pin 3	R280
Pin 4	Pin 4	R281
Pin 5	Pin 5	R282
Pin 6	Pin 6	R283
Pin 7	Pin 7	R284
Pin 8	Pin 8	R285

J85-J87

Schematic page 22

These headers are connected to banana jacks **J88**, **J89**, and **J90**.

J88-J90

Schematic page 22

These banana jacks are connected to headers **J85**, **J86**, and **J87**.

J91

Schematic page 3

This header is the PLL_BYPASS control. The default (logic low) is selected when a jumper is not present.

J92

Schematic page 3

This header is the PWRDN control. The default (logic low) is selected when a jumper is not present.

J93

Schematic page 6

This header is for any additional single ended I/O. Unused pins are connected to ground.

J93			
Pin 1	PT27C	Pin 2	GND
Pin 3	PT30A	Pin 4	GND
Pin 5	PT30D	Pin 6	GND
Pin 7	PT31D	Pin 8	PT32D
Pin 9	PT32C	Pin 10	GND

J99 - J102

Schematic page 10

These SMA connectors output the extra clock signals from the transponder.

J99	J100	J101	J102
RXMCLK_P	RXMCLK_N	TXMCLK_P	TXMCLK_N

J104

Schematic page 11

This SMA connector outputs the clock signal from Y5 or Y4 based on jumper placement in header **J74**.

J105 & J367

Schematic page 10

This SMA J105 connector inputs the XGMII_TXCLK_156 clock signal and J367 is input to XGMII_RXCLK_156 signal to the ORLI10G's XGMII interface.

J106

Schematic page 11

This SMA connector outputs the clock signal from Y6 or Y7 based on jumper placement in header **J75**.

J107-J110

Schematic page 13

These SMA connectors provide differential input to the PLL clocks. The pairs are:

J107	J109	J108	J110
PLL_CLK1C	PLL_CLK1T	PLL_CLK0C	PLL_CLK0T

J111

Schematic page 14

This 3 by 12 header is used to select the input to the transponder.

J8					
Pin 1	3.3V	Pin 2	LSENABLE	Pin 3	GND
Pin 4	3.3V	Pin 5	TXREFESL1	Pin 6	GND
Pin 7	3.3V	Pin 8	TXREFSEL0	Pin 9	GND
Pin 10	3.3V	Pin 11	RXREFSEL0	Pin 12	GND
Pin 13	3.3V	Pin 14	RXREFSEL1	Pin 15	GND
Pin 16	3.3V	Pin 17	RXMUTEDOUT	Pin 18	GND
Pin 19	3.3V	Pin 20	RXLCKREF	Pin 21	GND
Pin 22	3.3V	Pin 23	RXMCLKSEL	Pin 24	GND
Pin 25	3.3V	Pin 26	TXSKEWSEL0	Pin 27	GND
Pin 28	3.3V	Pin 29	TXSKEWSEL1	Pin 30	GND
Pin 31	3.3V	Pin 32	TXPCLKSEL	Pin 33	GND
Pin 34	3.3V	Pin 35	TXPICKSEL	Pin 36	GND

J112

Schematic page 14

Output signals from the transponder.

J112			
Pin 1	LSBIASMON	Pin 2	RESERVED1
Pin 3	LSBIASALM	Pin 4	RESERVED0
Pin 5	RXLOPMON	Pin 6	LSPOWMON
Pin 7	RXLOSMON	Pin 8	TXLOCKERR
Pin 9	RXLOCKERR	Pin 10	NC

J113, J114

Schematic page 4

These jumper headers select if either or both resets from **SW6** are applied to the transponder. If there is a jumper across **J113** then the transmit reset is applied when **SW6** is pushed. If there is a jumper across **J114** then the receive reset is applied when **SW6** is pushed. Both may be used at the same time, so that both are reset when **SW6** is pushed.

J115, J116

Schematic page 15

These banana jacks are connected to the positive analog 5V (**J115**) and the positive analog 3.3V (**J116**) of the transponder.

J117

Schematic page 15

This header allows the selection of the source of the digital 3.3V power to the transponder. Placing a jumper across pin 1 and 2 select the on-board 3.3V, while pin 3 and 2 select the banana jack **J118**.

J118

Schematic page 15

This banana jack is connected to the positive digital 3.3V of the transponder through the header **J117**.

J119, J120

Schematic page 15

These banana jacks are connected to the negative analog 5V (**J119**) and the negative digital 5V (**J120**) of the transponder.

J121, J122

Schematic page 18

These are 2X10 reference voltage headers. The extra pins are unconnected.

J121			
Pin 1	VREF_BL01	Pin 2	VREF_BL02
Pin 3	VREF_BL03	Pin 4	VREF_BL04
Pin 5	VREF_BL05	Pin 6	VREF_BL06
Pin 7	VREF_BL07	Pin 8	VREF_BL08
Pin 9	VREF_BL09	Pin 10	VREF_BL10
Pin 11	VREF_BL11	Pin 12	NC
Pin 13	NC	Pin 14	NC
Pin 15	NC	Pin 16	NC
Pin 17	NC	Pin 18	NC
Pin 19	NC	Pin 20	NC

J122			
Pin 1	VREF_BC08	Pin 2	VREF_BC07
Pin 3	VREF_BC06	Pin 4	VREF_BC05
Pin 5	VREF_BC04	Pin 6	VREF_BC03
Pin 7	VREF_BC02	Pin 8	VREF_BC01
Pin 9	NC	Pin 10	NC
Pin 11	NC	Pin 12	NC
Pin 13	NC	Pin 14	NC
Pin 15	NC	Pin 16	NC
Pin 17	NC	Pin 18	NC
Pin 19	NC	Pin 20	NC

J123

Schematic page 20

This banana jack is connected to the ground plane of the board.

J124, J125

Schematic page 13

J124 to **J125** are eight-pin headers (2X4) that control the termination of the differential clock input provided through SMAs **J107** to **J110**.

J126, J127

Schematic page 3

These 2X10 headers provide an output for any of the microstrip connectors. By jumpering from a Microstrip connector to **CON5**, one can conveniently view the output by reading it from a logic analyzer through headers **J126** and **J127**. The last two pins on one side of the header are connected to ground.

J126			
Pin 1	CON5.3	Pin 2	CON5.13
Pin 3	CON5.4	Pin 4	CON5.14
Pin 5	CON5.5	Pin 6	CON5.15
Pin 7	CON5.6	Pin 8	CON5.16
Pin 9	CON5.7	Pin 10	CON5.17
Pin 11	CON5.8	Pin 12	CON5.18
Pin 13	CON5.9	Pin 14	CON5.19
Pin 15	CON5.10	Pin 16	CON5.20
Pin 17	CON5.11	Pin 18	GND
Pin 19	CON5.12	Pin 20	GND

J127			
Pin 1	CON5.21	Pin 2	CON5.31
Pin 3	CON5.22	Pin 4	CON5.32
Pin 5	CON5.23	Pin 6	CON5.33
Pin 7	CON5.24	Pin 8	CON5.34
Pin 9	CON5.25	Pin 10	CON5.35
Pin 11	CON5.26	Pin 12	CON5.36
Pin 13	CON5.27	Pin 14	CON5.37
Pin 15	CON5.28	Pin 16	CON5.38
Pin 17	CON5.29	Pin 18	GND
Pin 19	CON5.30	Pin 20	GND

J128

Schematic page 12

This header selects between the socketed 155 MHz clock and clock provided via **J129**. The jumper controls half of the dual 2:1 MUX **U4**. The output is connected to TXREFCLK. Adding a jumper across pin one and two selects **J129** as the output. A jumper across pins two and three selects the 155 MHz clock.

J129

Schematic page 12

This SMA provides the input for the 622/644 MHz clock, if one is not generated from the transponder.

J130

Schematic page 12

This header selects between the socketed 155/156 MHz clock and clock provided via **J129**. The jumper controls half of the dual 2:1 multiplexer **U4**. The output is connected to another MUX, **U5**. Applying a jumper to pins one and two selects the 155 MHz clock on the output. Adding a jumper across pins two and three selects the clock provided via **J129**.

J131

Schematic page 12

This jumper selects the clock returning to the ORLI10G from the transponder. If pin 3 is selected, the transponder is assumed to be present and provided the TXPCLK. If pin 1 is selected the clock is provided on board from the output of **U4** (either the 155 MHz socketed oscillator or the clock input via **J129**).

J132

Schematic page 20

This banana jack is used to provide 0.75V to the board.

J133-J138

Schematic page 14

These are the additional synchronous clocks that are unused when the device is in 10G mode.

Connectors CON1 to CON5: CON 2

Schematic page 6

This Amp Micro-strip connector has 47 pins. The center row pins are grounded. Check the datasheet from www.amp.com (part number 536255-1) for pin number information. The Amp cable part is 621189. This connector provides test data from the FPGA to the XGMII interface.

CON 1	
Pin 1	GND
Pin 2	GND
Pin 3	PL3D
Pin 4	PL4B
Pin 5	PL7C
Pin 6	PL9A
Pin 7	PL11A
Pin 8	PL11C
Pin 9	PL13C
Pin 10	PL15C
Pin 11	PL16A
Pin 12	PL16C
Pin 13	PL17A
Pin 14	PL18C
Pin 15	PL20C
Pin 16	PL21C
Pin 17	PL23A
Pin 18	PL23C
Pin 19	PL24A
Pin 20	PL24C
Pin 21	PL25A
Pin 22	PL25C
Pin 23	PL26B
Pin 24	PL26C
Pin 25	PL29A
Pin 26	PL29C
Pin 27	PL30C
Pin 28	PL31A
Pin 29	PL31C
Pin 30	PL32A
Pin 31	PL33C
Pin 32	PL36A
Pin 33	PL36C
Pin 34	PL37B
Pin 35	PL38A
Pin 36	PL38B
Pin 37	PL38C
Pin 38	PL39C
Pin 39	GND
Pin 40	GND

CON 3

Schematic page 9

This Amp Micro-strip connector is connected to the XGMII control and data OUT signals.

CON2	XGMII
Pin 1	GND
Pin 2	GND
Pin 3	ctl out 0
Pin 4	ctl out 1
Pin 5	ctl out 2
Pin 6	ctl out 3
Pin 7	data out 0
Pin 8	data out 1
Pin 9	data out 2
Pin 10	data out 3
Pin 11	data out 4
Pin 12	data out 5
Pin 13	data out 6
Pin 14	data out 7
Pin 15	data out 8
Pin 16	data out 9
Pin 17	data out 10
Pin 18	data out 11
Pin 19	data out 12
Pin 20	data out 13
Pin 21	data out 14
Pin 22	data out 15
Pin 23	data out 16
Pin 24	data out 17
Pin 25	data out 18
Pin 26	data out 19
Pin 27	data out 20
Pin 28	data out 21
Pin 29	data out 22
Pin 30	data out 23
Pin 31	data out 24
Pin 32	data out 25
Pin 33	data out 26
Pin 34	data out 27
Pin 35	data out 28
Pin 36	data out 29
Pin 37	data out 30
Pin 38	data out 31
Pin 39	GND
Pin 40	GND

CON 4

Schematic page 9

This Amp Micro-strip connector is connected to the XGMII control and data IN signals.

CON2	XGMII
Pin 1	GND
Pin 2	GND
Pin 3	ctl in 0
Pin 4	ctl in 1
Pin 5	ctl in 2
Pin 6	ctl in 3
Pin 7	data in 0
Pin 8	data in 1
Pin 9	data in 2
Pin 10	data in 3
Pin 11	data in 4
Pin 12	data in 5
Pin 13	data in 6
Pin 14	data in 7
Pin 15	data in 8
Pin 16	data in 9
Pin 17	data in 10
Pin 18	data in 11
Pin 19	data in 12
Pin 20	data in 13
Pin 21	data in 14
Pin 22	data in 15
Pin 23	data in 16
Pin 24	data in 17
Pin 25	data in 18
Pin 26	data in 19
Pin 27	data in 20
Pin 28	data in 21
Pin 29	data in 22
Pin 30	data in 23
Pin 31	data in 24
Pin 32	data in 25
Pin 33	data in 26
Pin 34	data in 27
Pin 35	data in 28
Pin 36	data in 29
Pin 37	data in 30
Pin 38	data in 31
Pin 39	GND
Pin 40	GND

CON 5

Schematic page 3

This Amp Micro-strip connector is isolate from the ORLI10G. The purpose of this connector is to jump signals from the other microstrip headers to basic 2X10 headers where they can easily be viewed by a logic analyser. Typically a cable would jumper this header to **CON3** or **CON4**.

CON5	
Pin 1	GND
Pin 2	GND
Pin 3	J126.1
Pin 4	J126.3
Pin 5	J126.5
Pin 6	J126.7
Pin 7	J126.9
Pin 8	J126.11
Pin 9	J126.13
Pin 10	J126.15
Pin 11	J126.17
Pin 12	J126.19
Pin 13	J126.2
Pin 14	J126.4
Pin 15	J126.6
Pin 16	J126.8
Pin 17	J126.10
Pin 18	J126.12
Pin 19	J126.14
Pin 20	J126.16
Pin 21	J127.1
Pin 22	J127.3
Pin 23	J127.5
Pin 24	J127.7
Pin 25	J127.9
Pin 26	J127.11
Pin 27	J127.13
Pin 28	J127.15
Pin 29	J127.17
Pin 30	J127.19
Pin 31	J127.2
Pin 32	J127.4
Pin 33	J127.6
Pin 34	J127.8
Pin 35	J127.10
Pin 36	J127.12
Pin 37	J127.14
Pin 38	J127.16
Pin 39	GND
Pin 40	GND

Adjustable resistors:

R261

Schematic page 18

This adjustable resistor is used along with test point (reference **TP10**) to set the 1.4 Volts reference for the ORLI10G.

R264

Schematic page 18

This adjustable resistor is used along with test point (reference **TP9**) to set the 1.0 Volts reference for the ORLI10G.

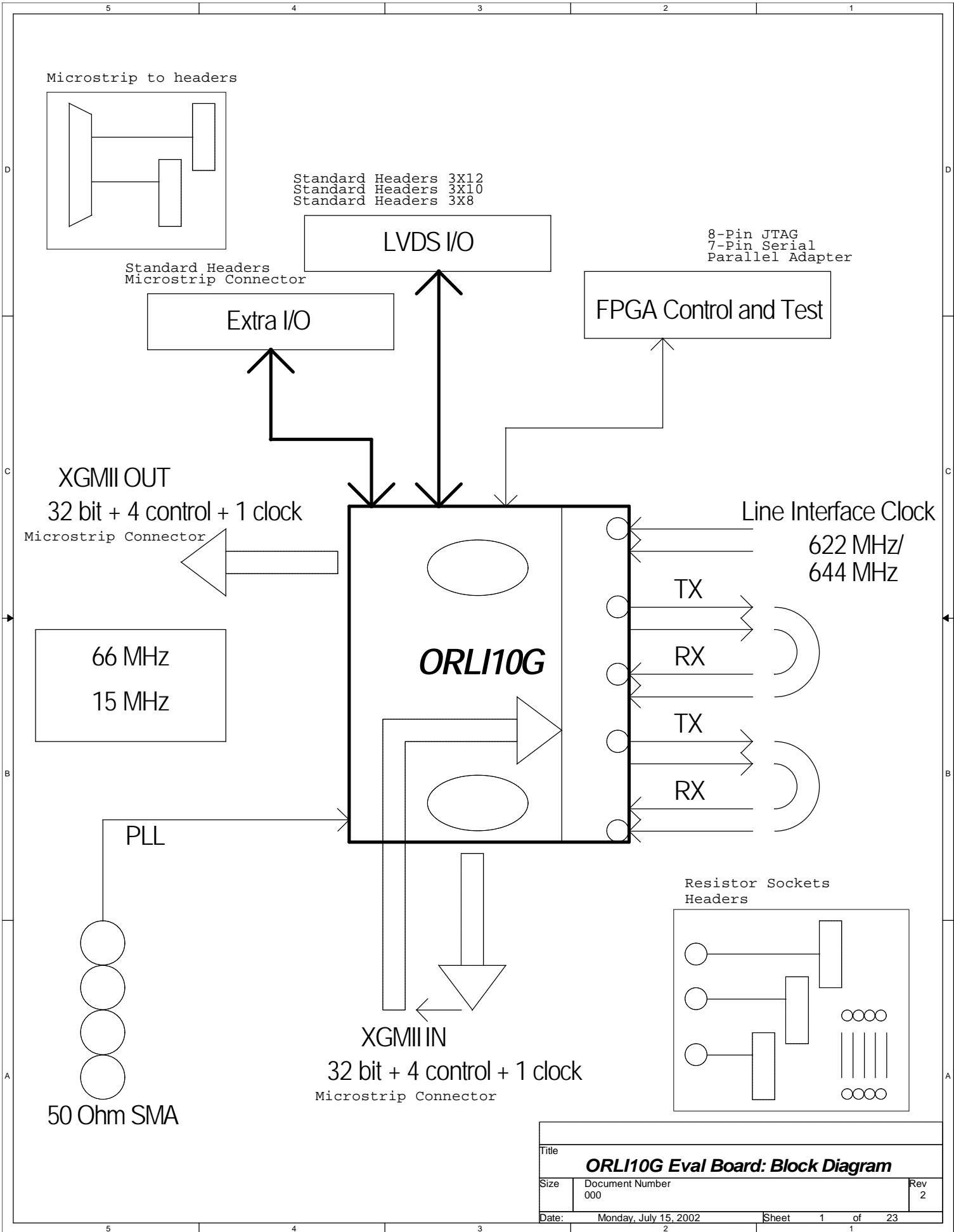

Title		
ORLI10G Eval Board: Block Diagram		
Size	Document Number	Rev
	000	2
Date:	Monday, July 15, 2002	Sheet 1 of 23
	2	1

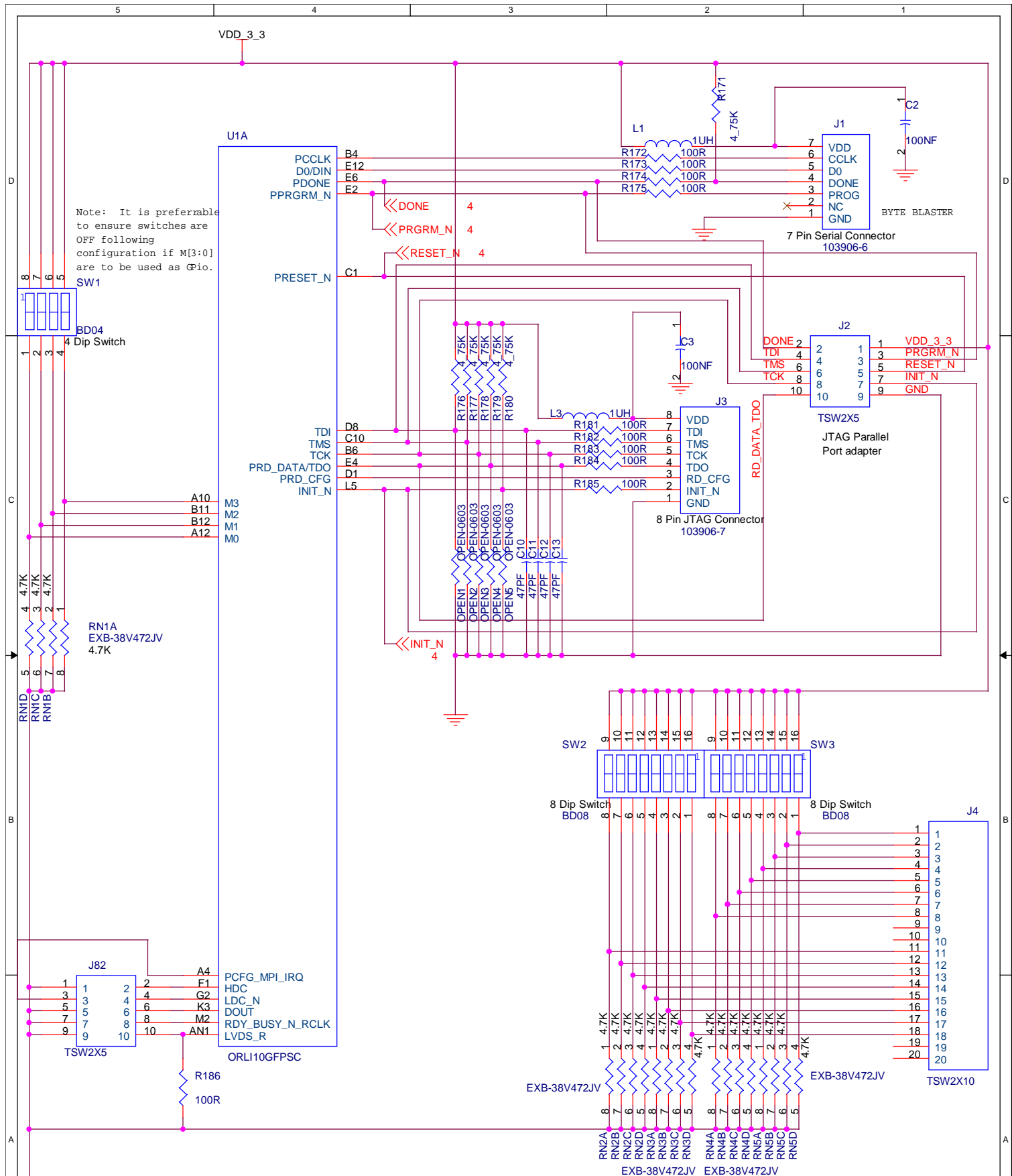

Title		
ORL10G Eval Board: JTAG		
Size	Document Number	Rev
	000	2
Date:	Monday, July 15, 2002	Sheet 2 of 23

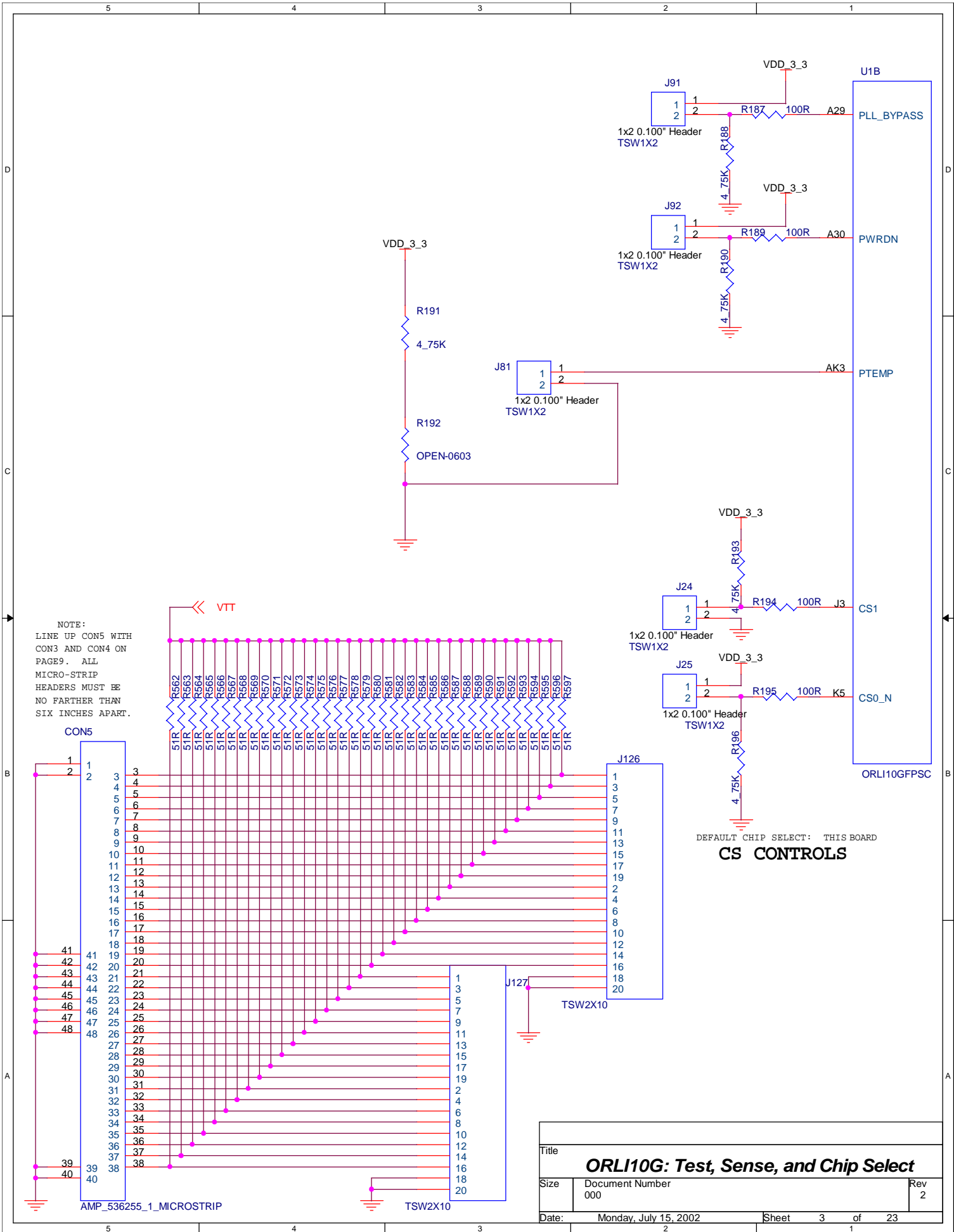

NOTE:
 LINE UP CON5 WITH
 CON3 AND CON4 ON
 PAGE9. ALL
 MICRO-STRIP
 HEADERS MUST BE
 NO FARTHER THAN
 SIX INCHES APART.

DEFAULT CHIP SELECT: THIS BOARD
CS CONTROLS

Title		
ORL110G: Test, Sense, and Chip Select		
Size	Document Number	Rev
	000	2
Date:	Monday, July 15, 2002	Sheet 3 of 23

NOTE: THESE LEDs ARE DESIGNED TO OPERATE ON 3.3V. IF A LOWER VOLTAGE IS APPLIED LIGHT MAY BE DIM OR NIL.

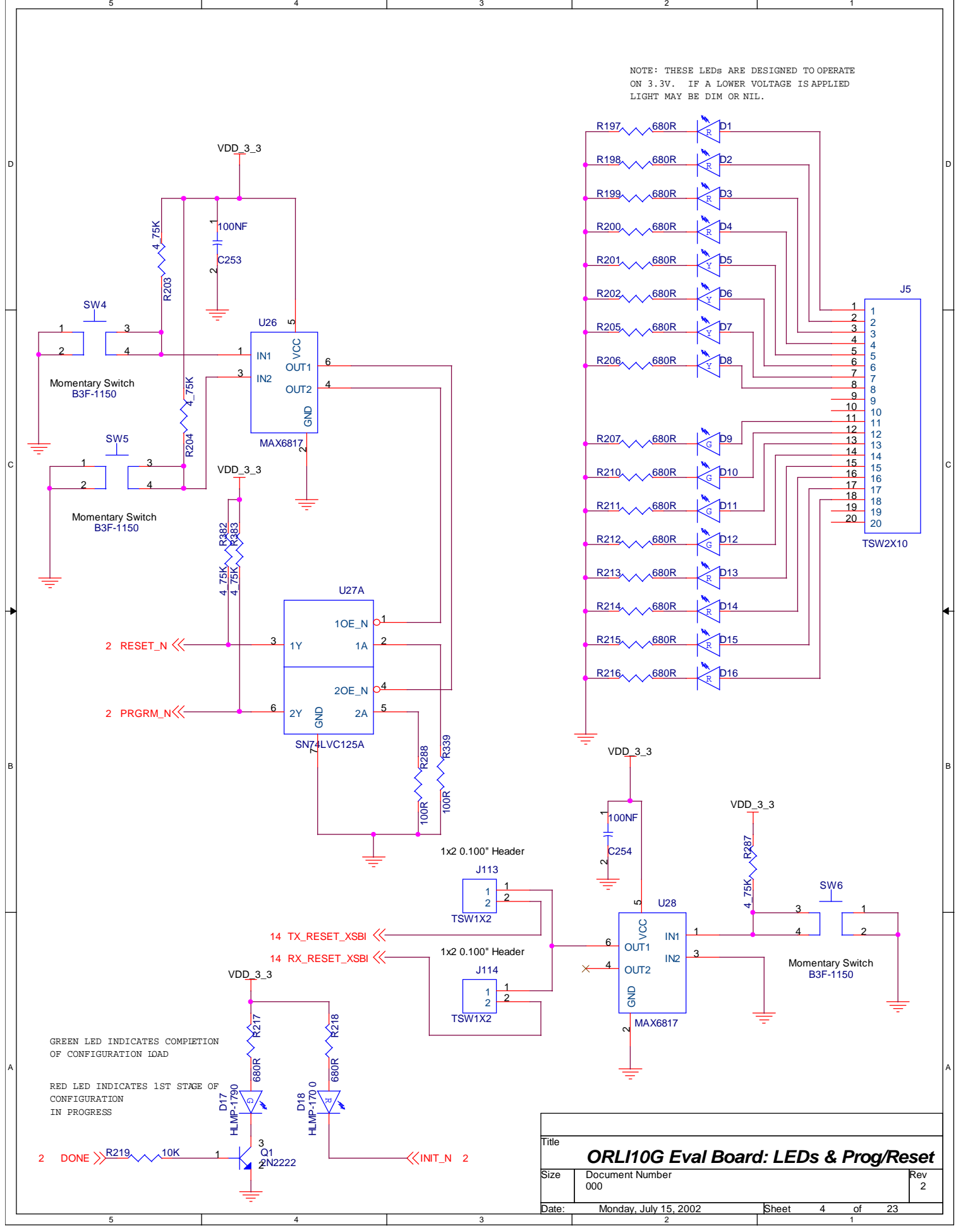

GREEN LED INDICATES COMPLETION OF CONFIGURATION LOAD
 RED LED INDICATES 1ST STAGE OF CONFIGURATION IN PROGRESS

Title		
ORL10G Eval Board: LEDs & Prog/Reset		
Size	Document Number	Rev
	000	2
Date:	Monday, July 15, 2002	Sheet 4 of 23

U1C

CON1B

TX_DAT_OUT_10_P	T31	XSBI_TX_P_00	A16	TXDIN0P
TX_DAT_OUT_10_N	T30	XSBI_TX_N_00	A17	TXDIN0N
TX_DAT_OUT_11_P	R33	XSBI_TX_P_01	A19	TXDIN1P
TX_DAT_OUT_11_N	R32	XSBI_TX_N_01	A20	TXDIN1N
TX_DAT_OUT_12_P	R31	XSBI_TX_P_02	A22	TXDIN2P
TX_DAT_OUT_12_N	R30	XSBI_TX_N_02	A23	TXDIN2N
TX_DAT_OUT_13_P	N33	XSBI_TX_P_03	A25	TXDIN3P
TX_DAT_OUT_13_N	P32	XSBI_TX_N_03	A26	TXDIN3N
TX_DAT_OUT_20_P	N32	XSBI_TX_P_04	C16	TXDIN4P
TX_DAT_OUT_20_N	N31	XSBI_TX_N_04	C17	TXDIN4N
TX_DAT_OUT_21_P	M33	XSBI_TX_P_05	C19	TXDIN5P
TX_DAT_OUT_21_N	M32	XSBI_TX_N_05	C20	TXDIN5N
TX_DAT_OUT_22_P	M31	XSBI_TX_P_06	C22	TXDIN6P
TX_DAT_OUT_22_N	M30	XSBI_TX_N_06	C23	TXDIN6N
TX_DAT_OUT_23_P	L32	XSBI_TX_P_07	C25	TXDIN7P
TX_DAT_OUT_23_N	K32	XSBI_TX_N_07	C26	TXDIN7N
TX_DAT_OUT_30_P	J31	XSBI_TX_P_08	E16	TXDIN8P
TX_DAT_OUT_30_N	K31	XSBI_TX_N_08	E17	TXDIN8N
TX_DAT_OUT_31_P	H33	XSBI_TX_P_09	E19	TXDIN9P
TX_DAT_OUT_31_N	J32	XSBI_TX_N_09	E20	TXDIN9N
TX_DAT_OUT_32_P	G31	XSBI_TX_P_10	E22	TXDIN10P
TX_DAT_OUT_32_N	F32	XSBI_TX_N_10	E23	TXDIN10N
TX_DAT_OUT_33_P	E33	XSBI_TX_P_11	E25	TXDIN11P
TX_DAT_OUT_33_N	E32	XSBI_TX_N_11	E26	TXDIN11N
TX_DAT_OUT_40_P	B31	XSBI_TX_P_12	G16	TXDIN12P
TX_DAT_OUT_40_N	A32	XSBI_TX_N_12	G17	TXDIN12N
TX_DAT_OUT_41_P	E26	XSBI_TX_P_13	G19	TXDIN13P
TX_DAT_OUT_41_N	E27	XSBI_TX_N_13	G20	TXDIN13N
TX_DAT_OUT_42_P	C29	XSBI_TX_P_14	G22	TXDIN14P
TX_DAT_OUT_42_N	D29	XSBI_TX_N_14	G23	TXDIN14N
TX_DAT_OUT_43_P	D27	XSBI_TX_P_15	G25	TXDIN15P
TX_DAT_OUT_43_N	C28	XSBI_TX_N_15	G26	TXDIN15N

ORLI10GFPSC

NOTE: ROUTE DATA ALONG
WITH CLOCK SIGNAL NAMED
XSBI_TX_[P/N]_CLK ON
PAGE 14.

megArray

NOTE: ROUTE DATA ALONG
WITH CLOCK SIGNAL NAMED
XSBI_RX_[P/N]_CLK ON
PAGE 14.

U1D

CON1A

RX_DAT_IN_10_P	AL27	XSBI_RX_P_00	A1	RXDOUT0P
RX_DAT_IN_10_N	AM28	XSBI_RX_N_00	A2	RXDOUT0N
RX_DAT_IN_11_P	AN29	XSBI_RX_P_01	A4	RXDOUT1P
RX_DAT_IN_11_N	AP30	XSBI_RX_N_01	A5	RXDOUT1N
RX_DAT_IN_12_P	AL28	XSBI_RX_P_02	A7	RXDOUT2P
RX_DAT_IN_12_N	AM29	XSBI_RX_N_02	A8	RXDOUT2N
RX_DAT_IN_13_P	AK27	XSBI_RX_P_03	A10	RXDOUT3P
RX_DAT_IN_13_N	AK28	XSBI_RX_N_03	A11	RXDOUT3N
RX_DAT_IN_20_P	AK33	XSBI_RX_P_04	C1	RXDOUT4P
RX_DAT_IN_20_N	AJ32	XSBI_RX_N_04	C2	RXDOUT4N
RX_DAT_IN_21_P	AH31	XSBI_RX_P_05	C4	RXDOUT5P
RX_DAT_IN_21_N	AG30	XSBI_RX_N_05	C5	RXDOUT5N
RX_DAT_IN_22_P	AE30	XSBI_RX_P_06	C7	RXDOUT6P
RX_DAT_IN_22_N	AG31	XSBI_RX_N_06	C8	RXDOUT6N
RX_DAT_IN_23_P	AK34	XSBI_RX_P_07	C10	RXDOUT7P
RX_DAT_IN_23_N	AJ33	XSBI_RX_N_07	C11	RXDOUT7N
RX_DAT_IN_30_P	AC30	XSBI_RX_P_08	E1	RXDOUT8P
RX_DAT_IN_30_N	AD30	XSBI_RX_N_08	E2	RXDOUT8N
RX_DAT_IN_31_P	AE31	XSBI_RX_P_09	E4	RXDOUT9P
RX_DAT_IN_31_N	AE32	XSBI_RX_N_09	E5	RXDOUT9N
RX_DAT_IN_32_P	AD31	XSBI_RX_P_10	E7	RXDOUT10P
RX_DAT_IN_32_N	AD32	XSBI_RX_N_10	E8	RXDOUT10N
RX_DAT_IN_33_P	AC31	XSBI_RX_P_11	E10	RXDOUT11P
RX_DAT_IN_33_N	AC32	XSBI_RX_N_11	E11	RXDOUT11N
RX_DAT_IN_40_P	AA32	XSBI_RX_P_12	G1	RXDOUT12P
RX_DAT_IN_40_N	AA33	XSBI_RX_N_12	G2	RXDOUT12N
RX_DAT_IN_41_P	Y31	XSBI_RX_P_13	G4	RXDOUT13P
RX_DAT_IN_41_N	Y32	XSBI_RX_N_13	G5	RXDOUT13N
RX_DAT_IN_42_P	W31	XSBI_RX_P_14	G7	RXDOUT14P
RX_DAT_IN_42_N	W32	XSBI_RX_N_14	G8	RXDOUT14N
RX_DAT_IN_43_P	V30	XSBI_RX_P_15	G10	RXDOUT15P
RX_DAT_IN_43_N	V31	XSBI_RX_N_15	G11	RXDOUT15N

ORLI10GFPSC

megArray

Title		
ORLI0G Eval Board: XSBI RX / TX Data		
Size	Document Number	Rev
	000	2
Date:	Monday, July 15, 2002	Sheet 5 of 23

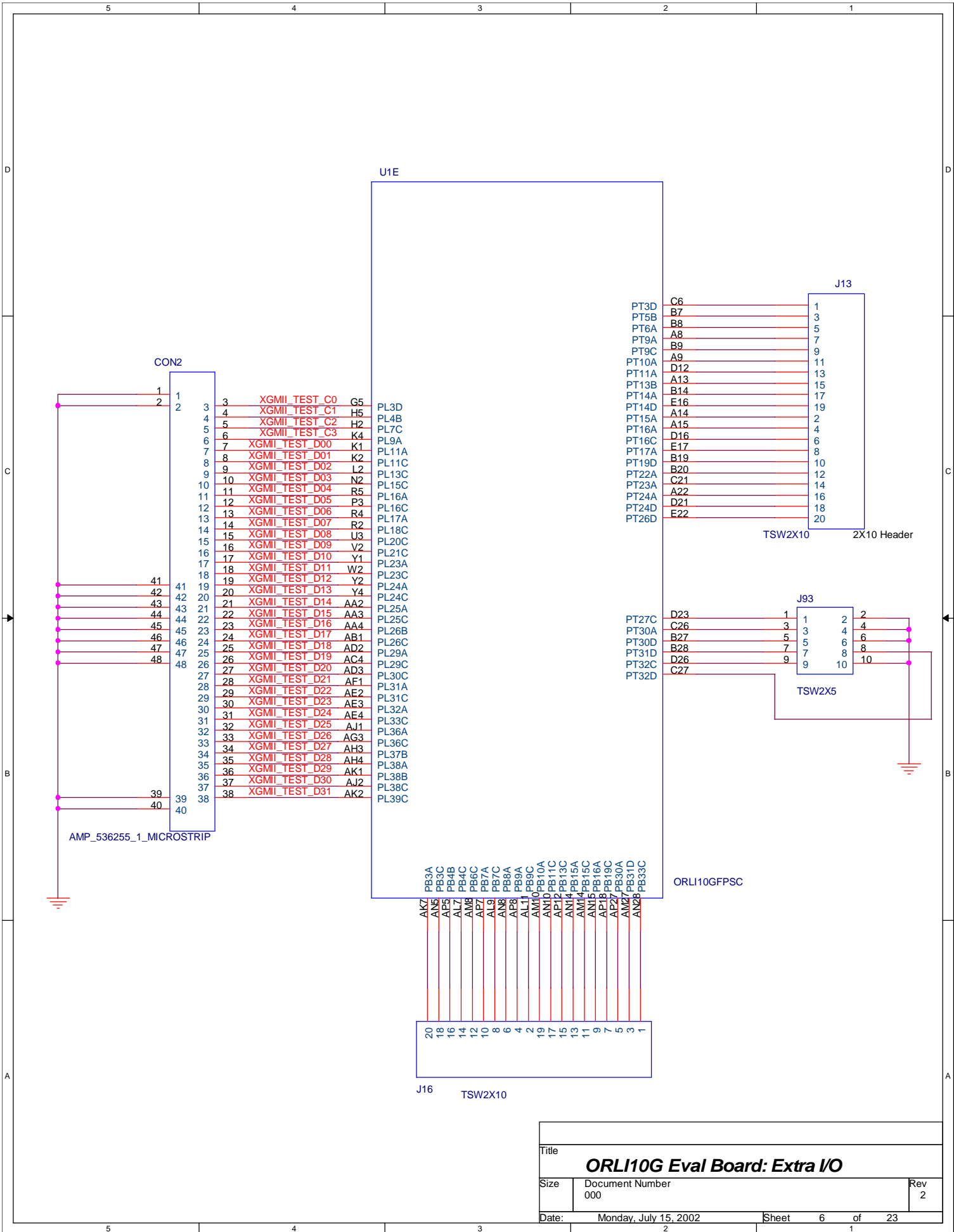

Title		
ORL110G Eval Board: Extra I/O		
Size	Document Number	Rev
	000	2
Date:	Monday, July 15, 2002	Sheet 6 of 23

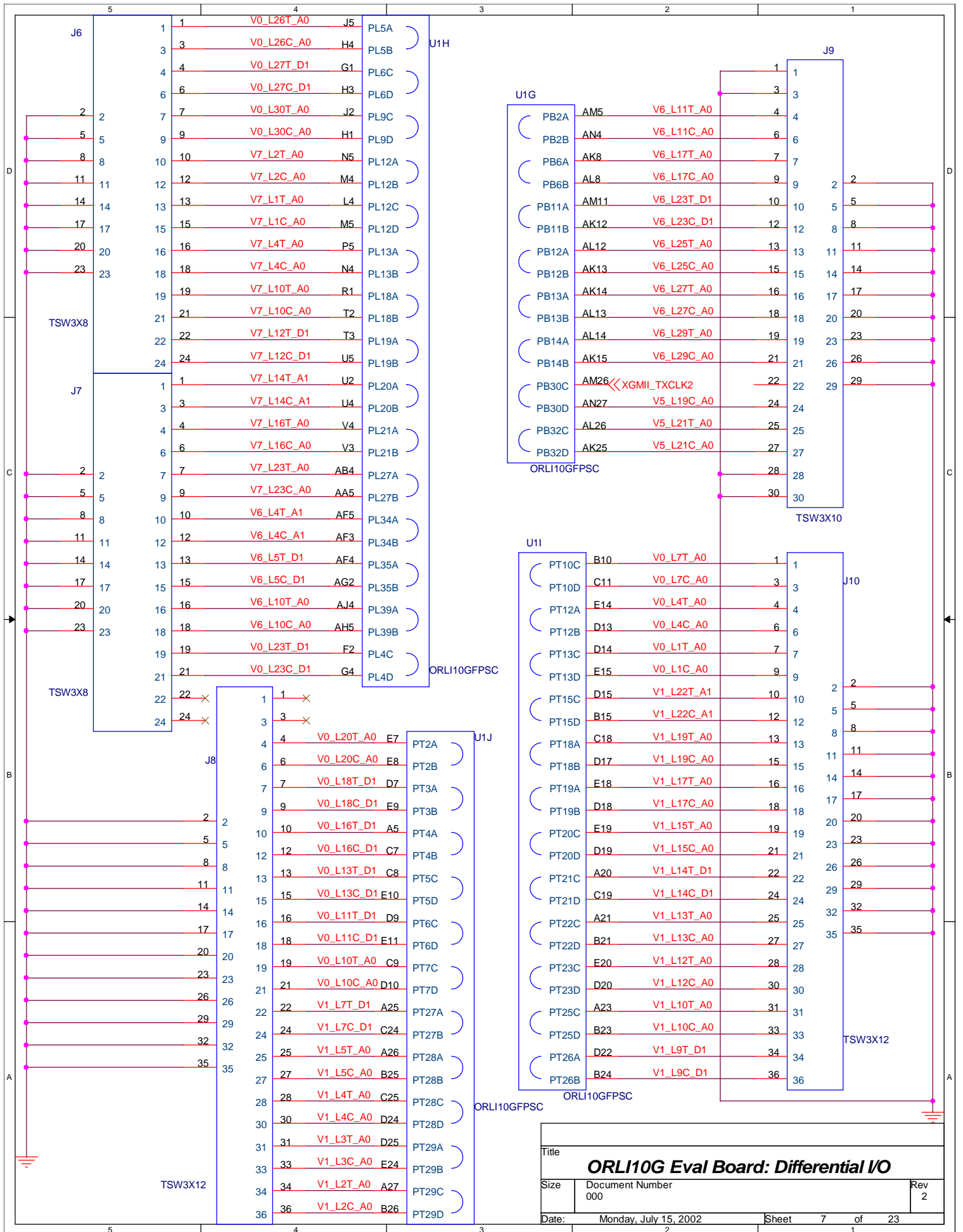

Title		
ORL10G Eval Board: Differential I/O		
Size	Document Number	Rev
	000	2
Date:	Monday, July 15, 2002	Sheet 7 of 23

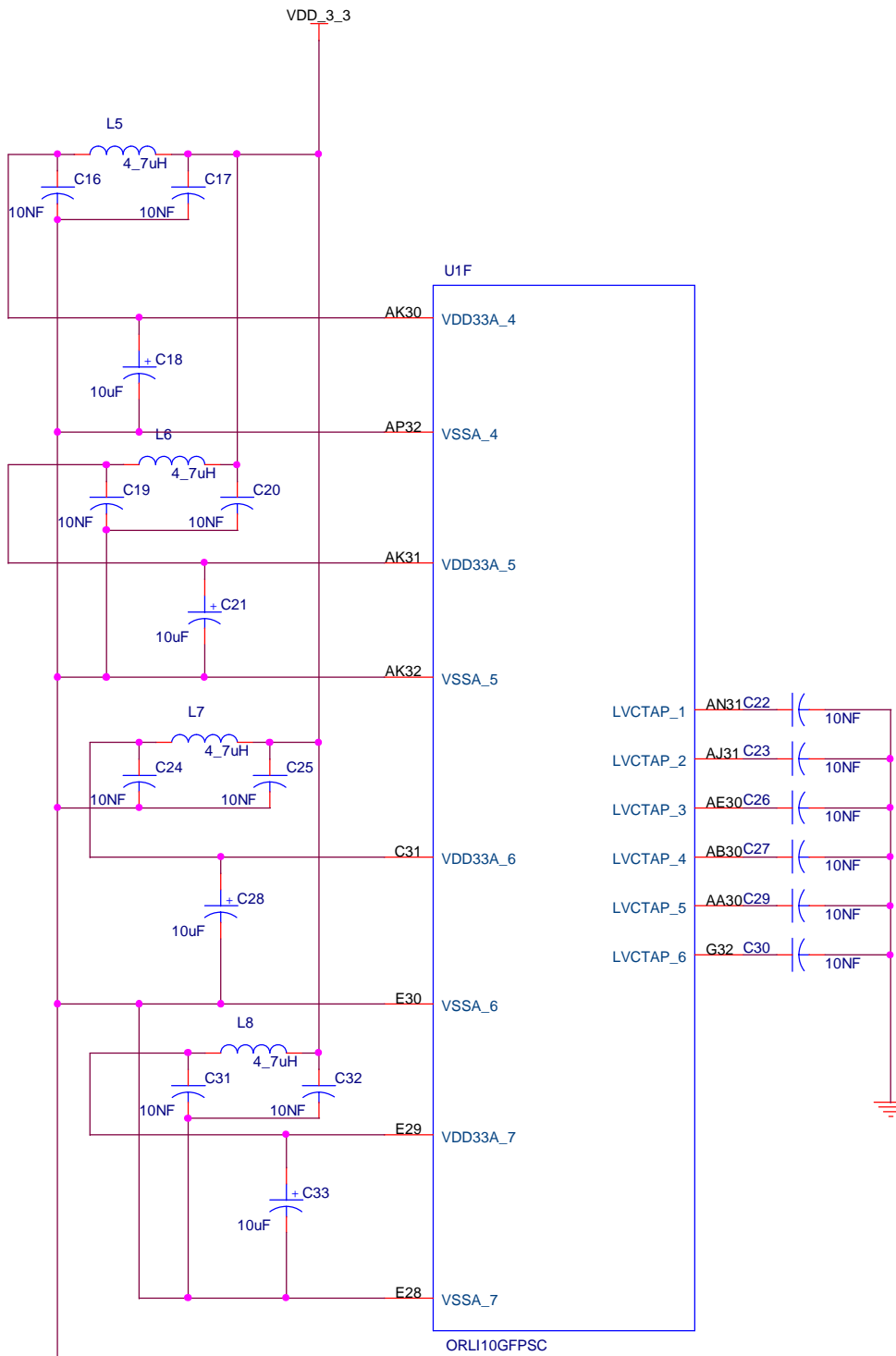

Title		
ORL10G Eval Board: Center Tap		
Size	Document Number	Rev
	000	2
Date:	Monday, July 15, 2002	Sheet 8 of 23
	2	1

Note: Pins 1, 2, 39, and 40 are not connected on a standard Micro-Strip cable.

Note: Pins 41 - 47 are center grounds.

Note: Pins 1, 2, 39, and 40 are not connected on a standard Micro-Strip cable.

Note: Pins 41 - 47 are center grounds.

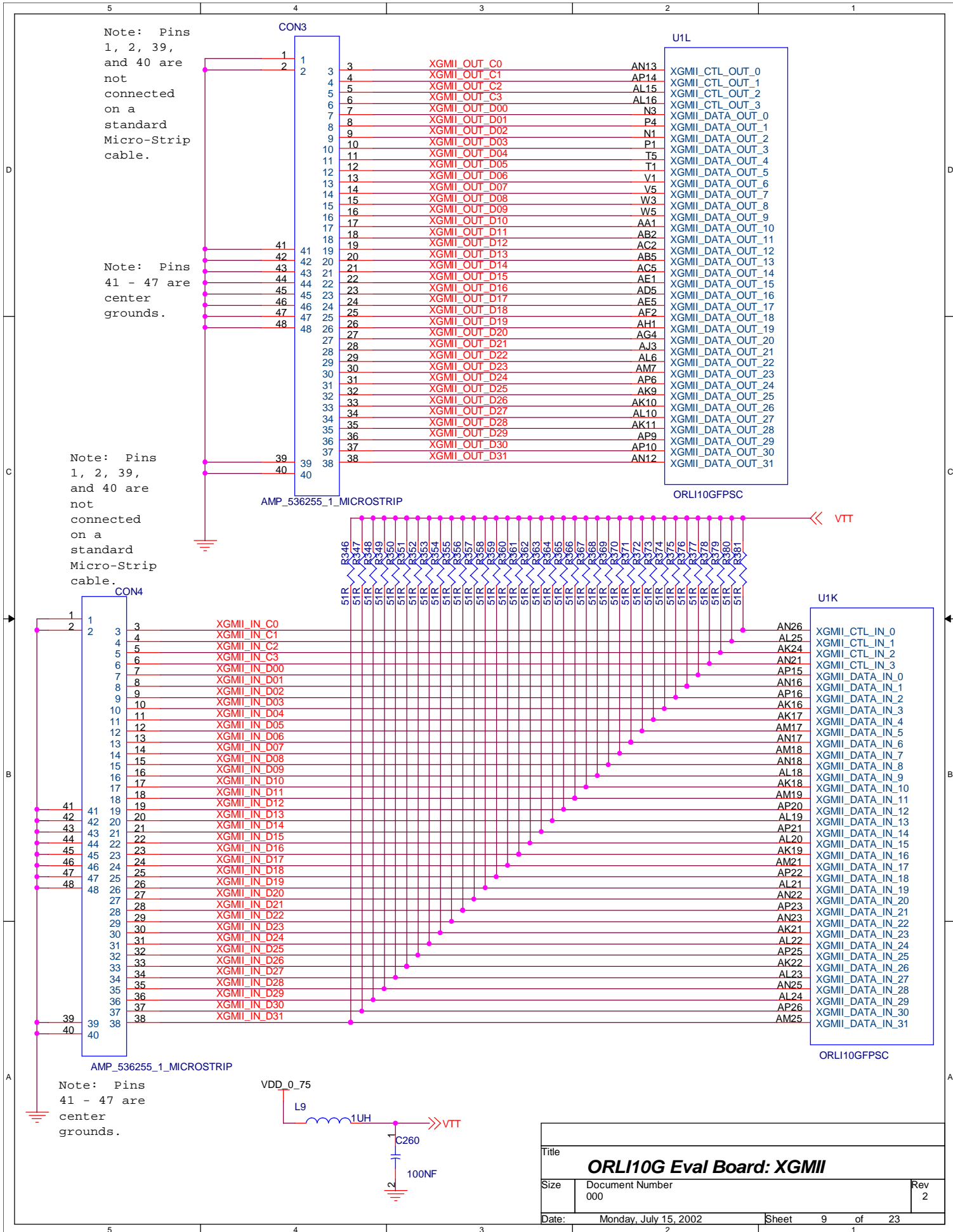

Title		
ORL10G Eval Board: XGMII		
Size	Document Number	Rev
	000	2
Date:	Monday, July 15, 2002	Sheet 9 of 23

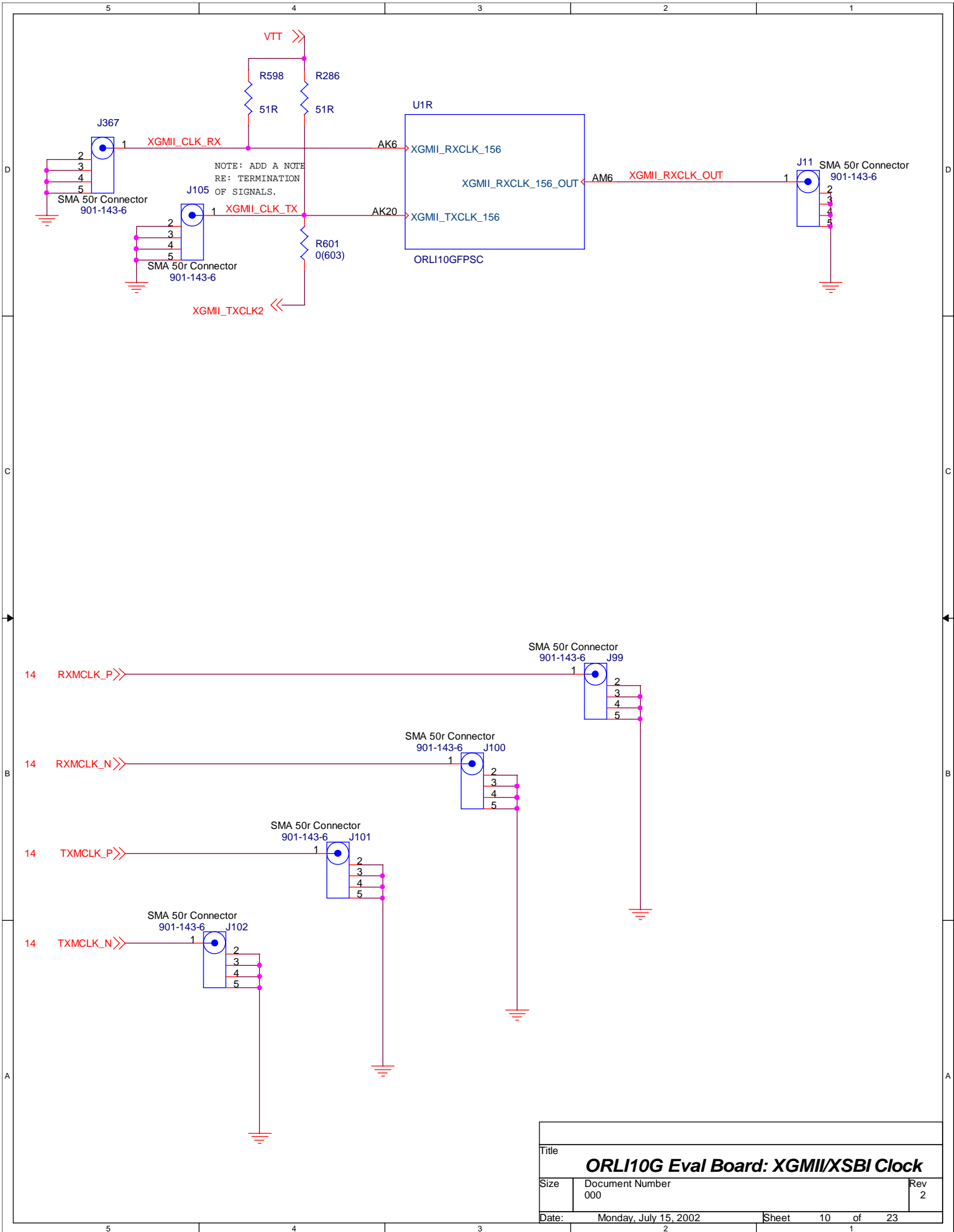

Title		
ORL10G Eval Board: XGMII/XSBI Clock		
Size	Document Number	Rev
	000	2
Date:	Monday, July 15, 2002	Sheet 10 of 23
	2	1

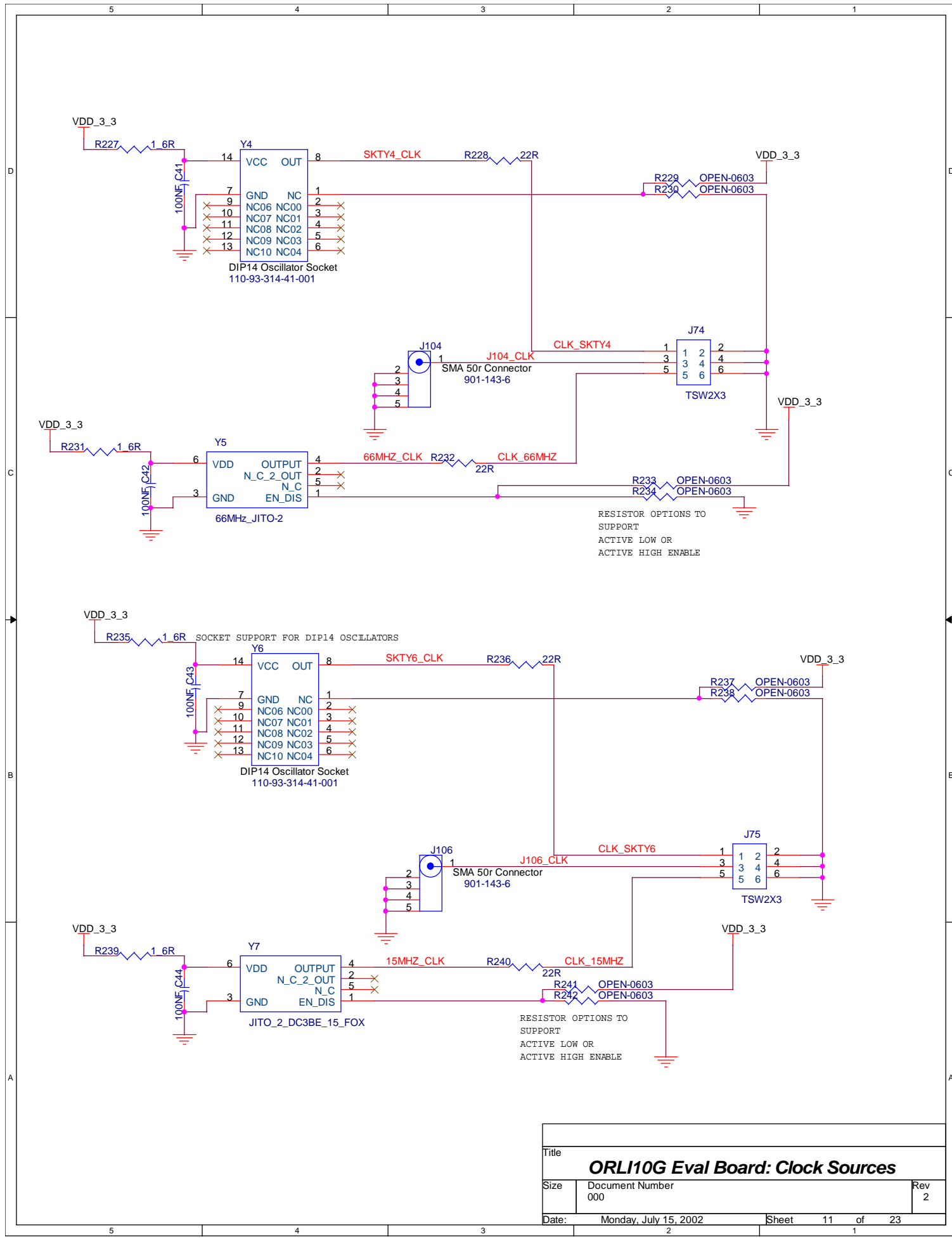

Title		
ORL10G Eval Board: Clock Sources		
Size	Document Number	Rev
	000	2
Date:	Monday, July 15, 2002	Sheet 11 of 23

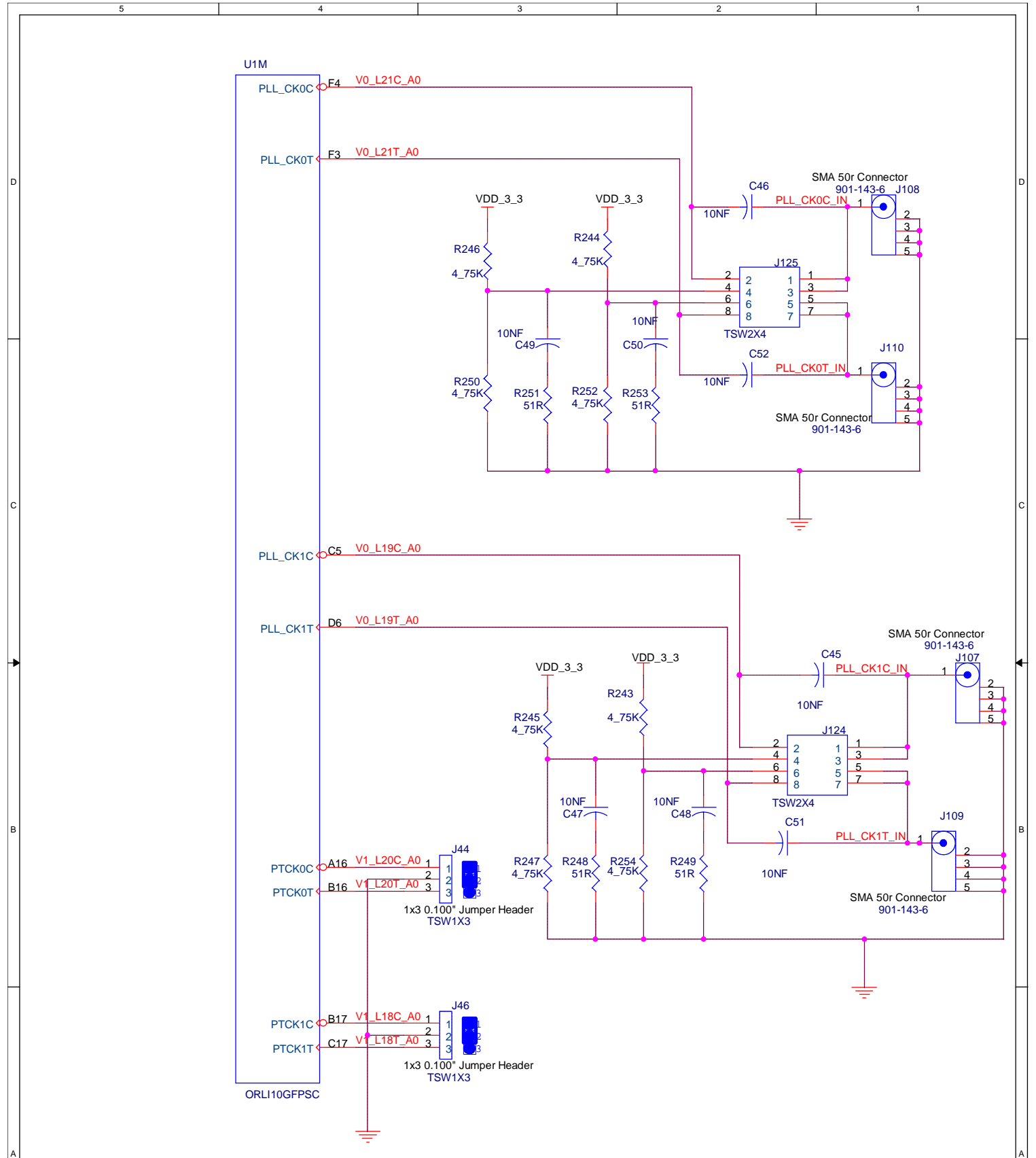

Title		
ORL10G Eval Board: PLL Clock		
Size	Document Number	Rev
	000	2
Date:	Monday, July 15, 2002	Sheet 13 of 23

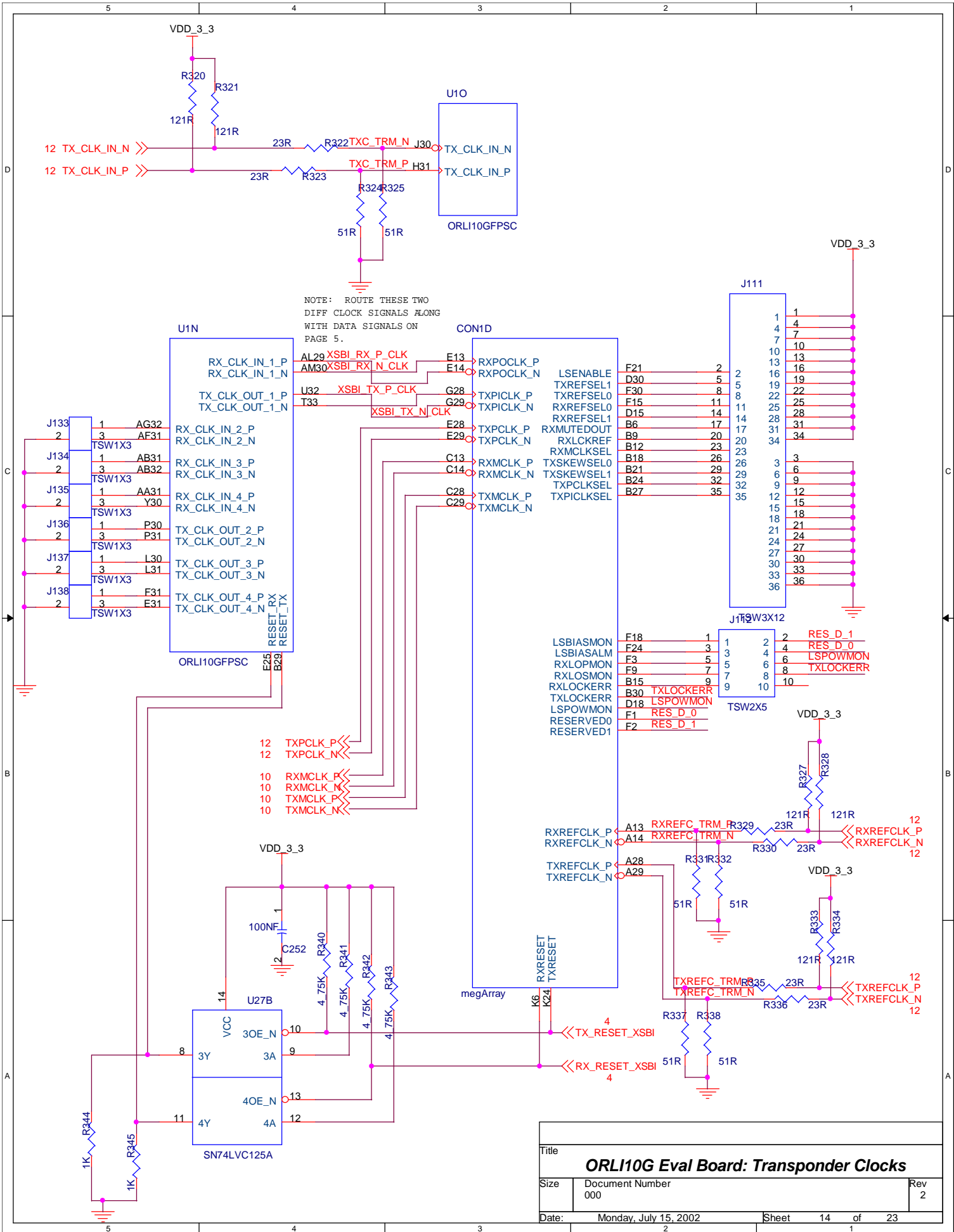

Title		
ORL10G Eval Board: Transponder Clocks		
Size	Document Number	Rev
	000	2
Date:	Monday, July 15, 2002	Sheet 14 of 23

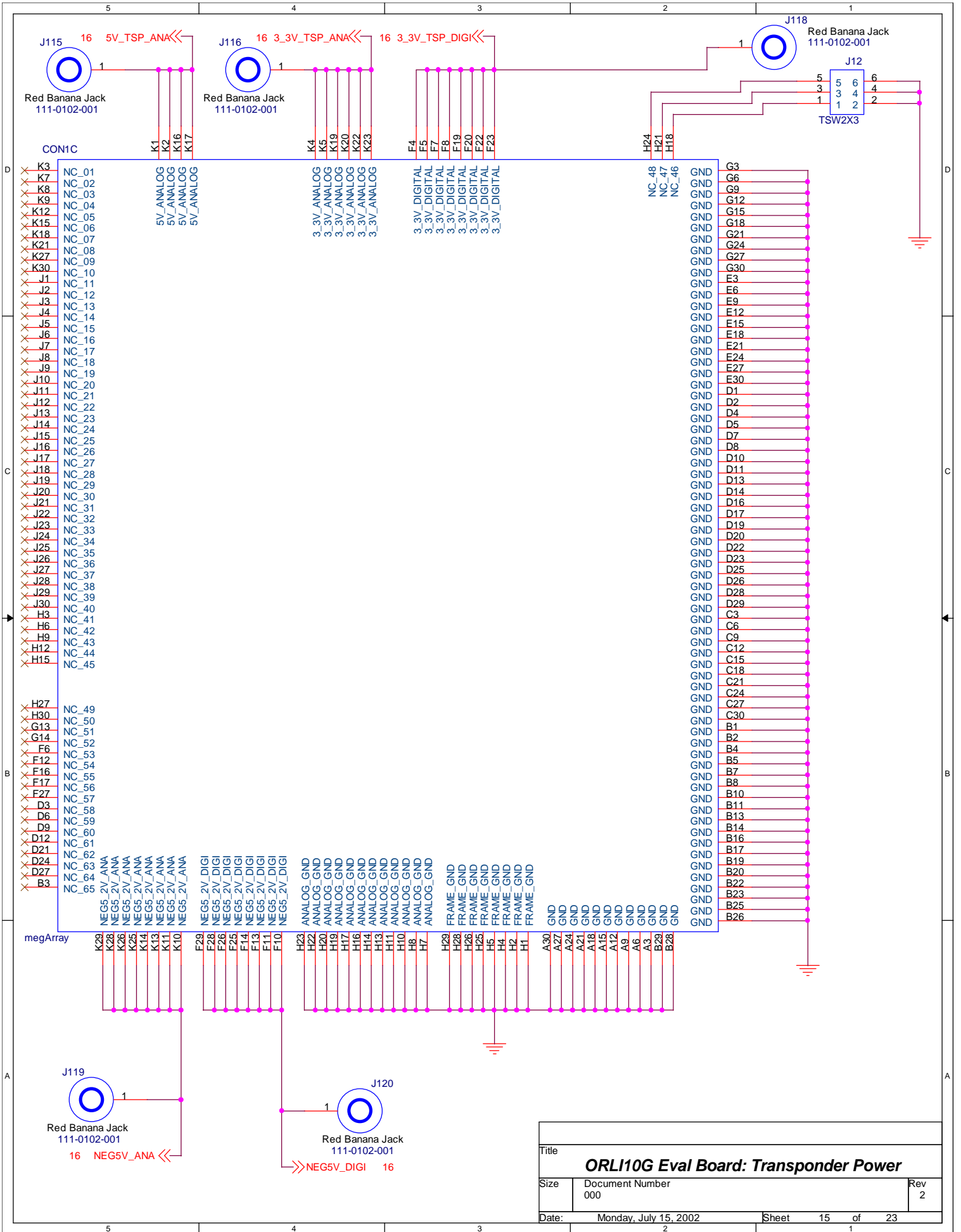

Title		
ORL10G Eval Board: Transponder Power		
Size	Document Number	Rev
	000	2
Date:	Monday, July 15, 2002	Sheet 15 of 23

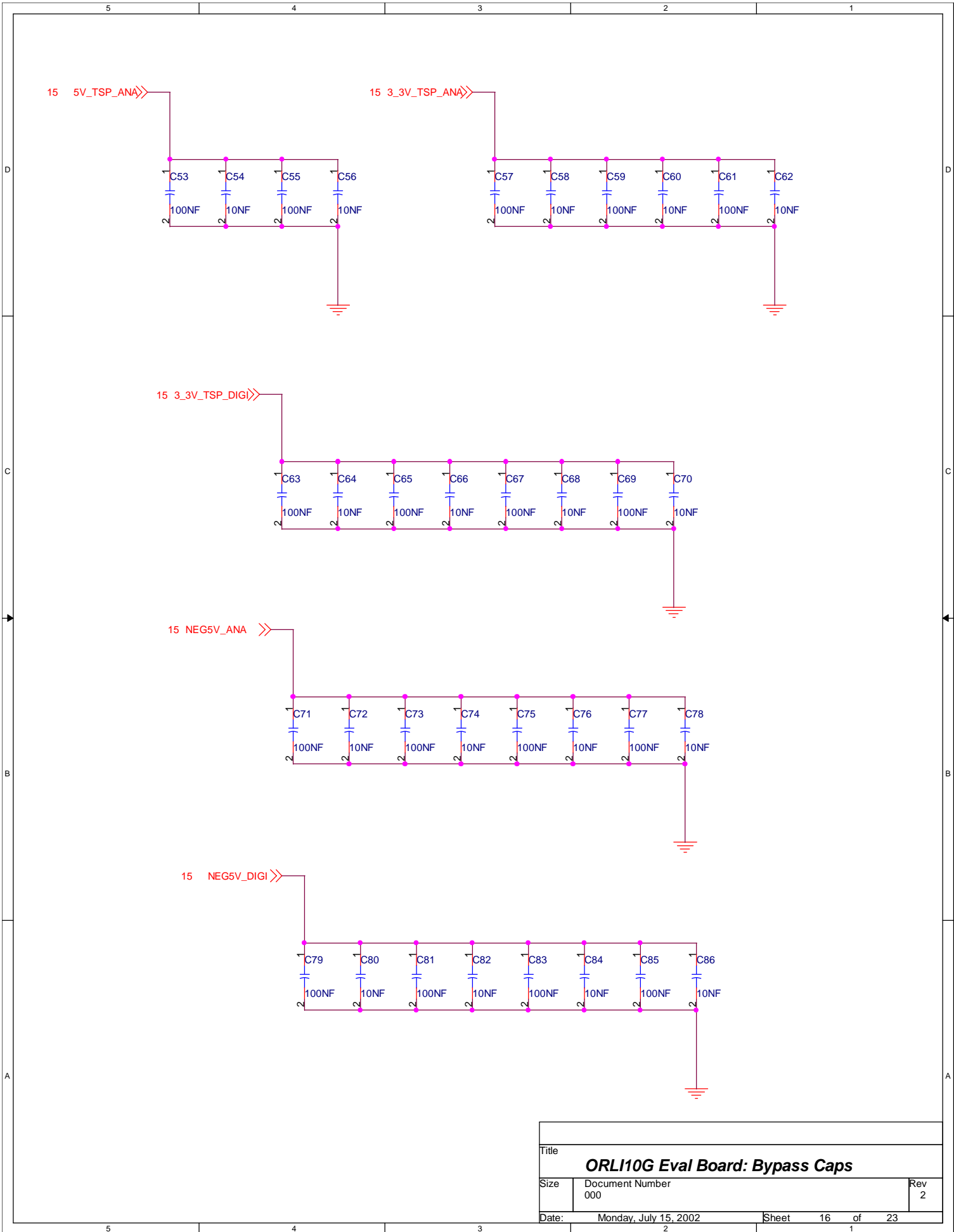

Title		
ORL110G Eval Board: Bypass Caps		
Size	Document Number	Rev
	000	2
Date:	Monday, July 15, 2002	Sheet 16 of 23

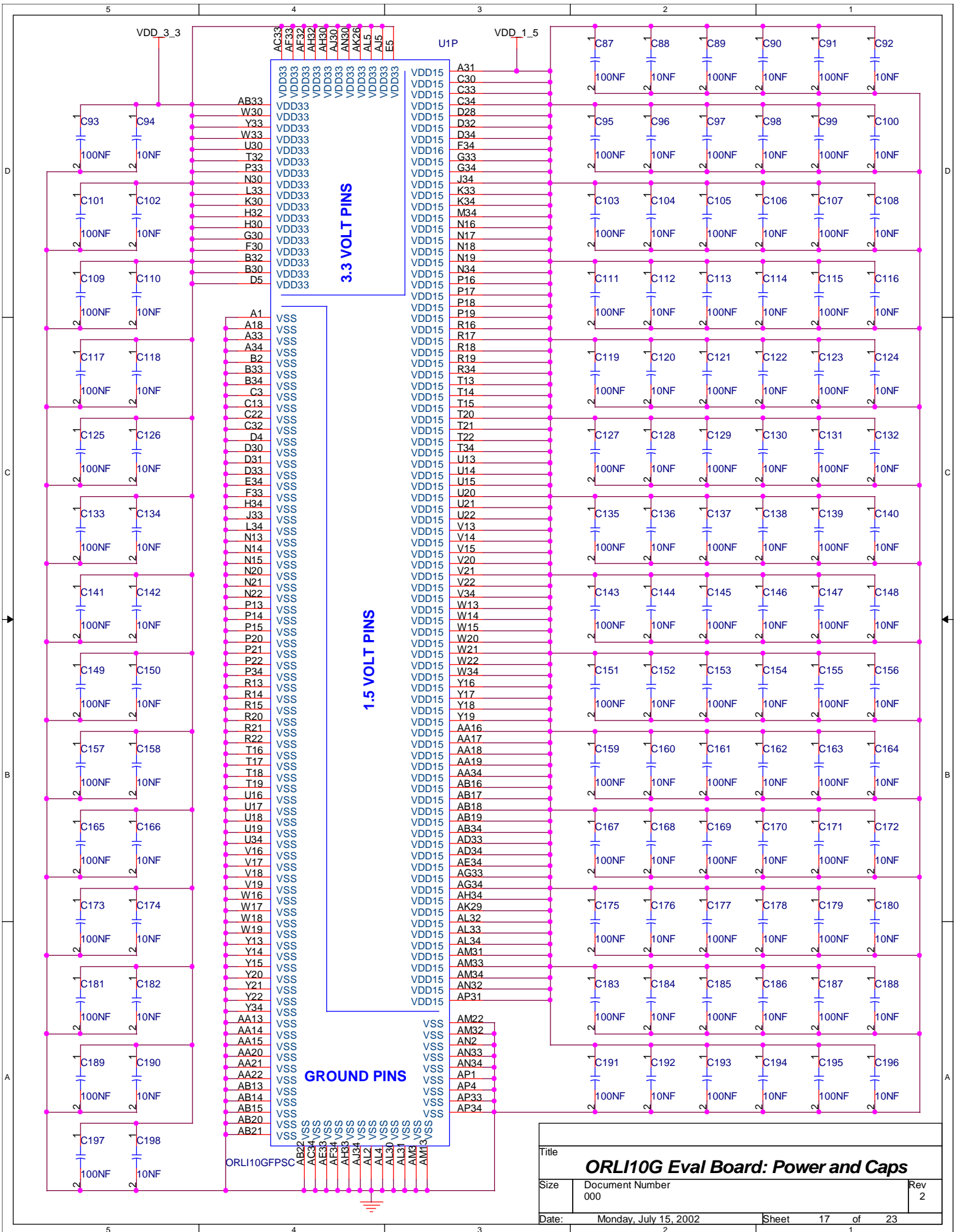

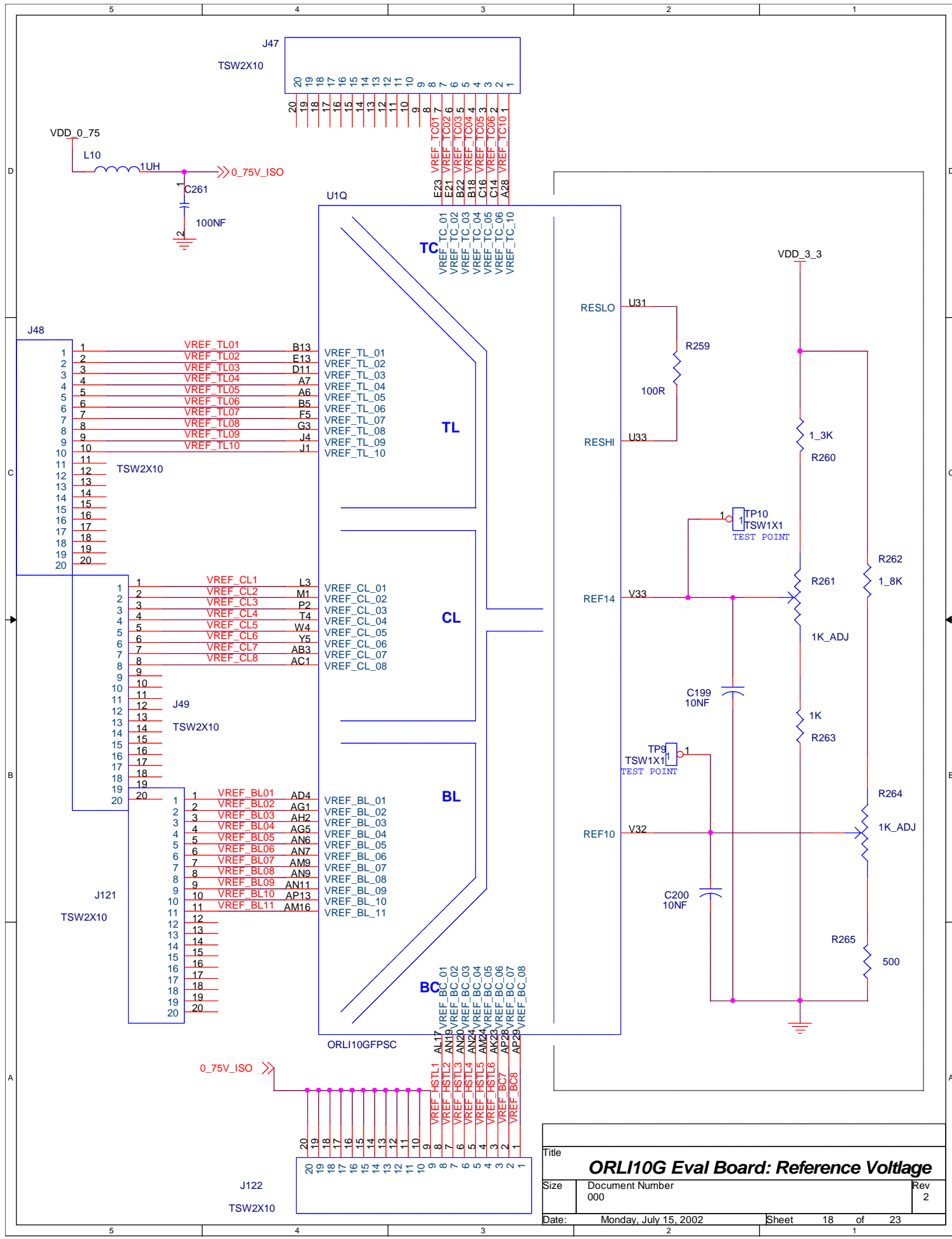

Title		
ORL10G Eval Board: Reference Voltage		
Size	Document Number	Rev
	000	2
Date:	Monday, July 15, 2002	Sheet 18 of 23

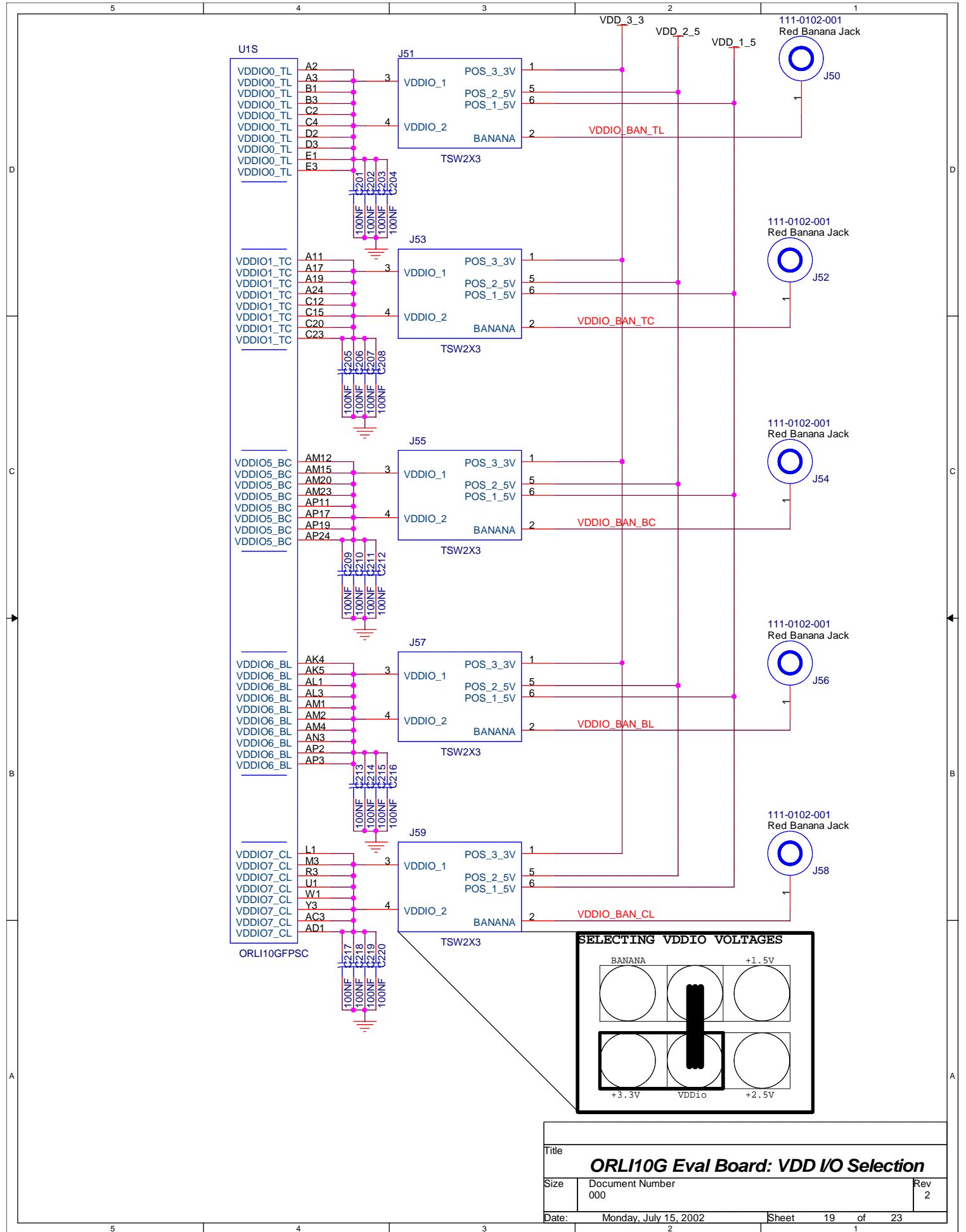

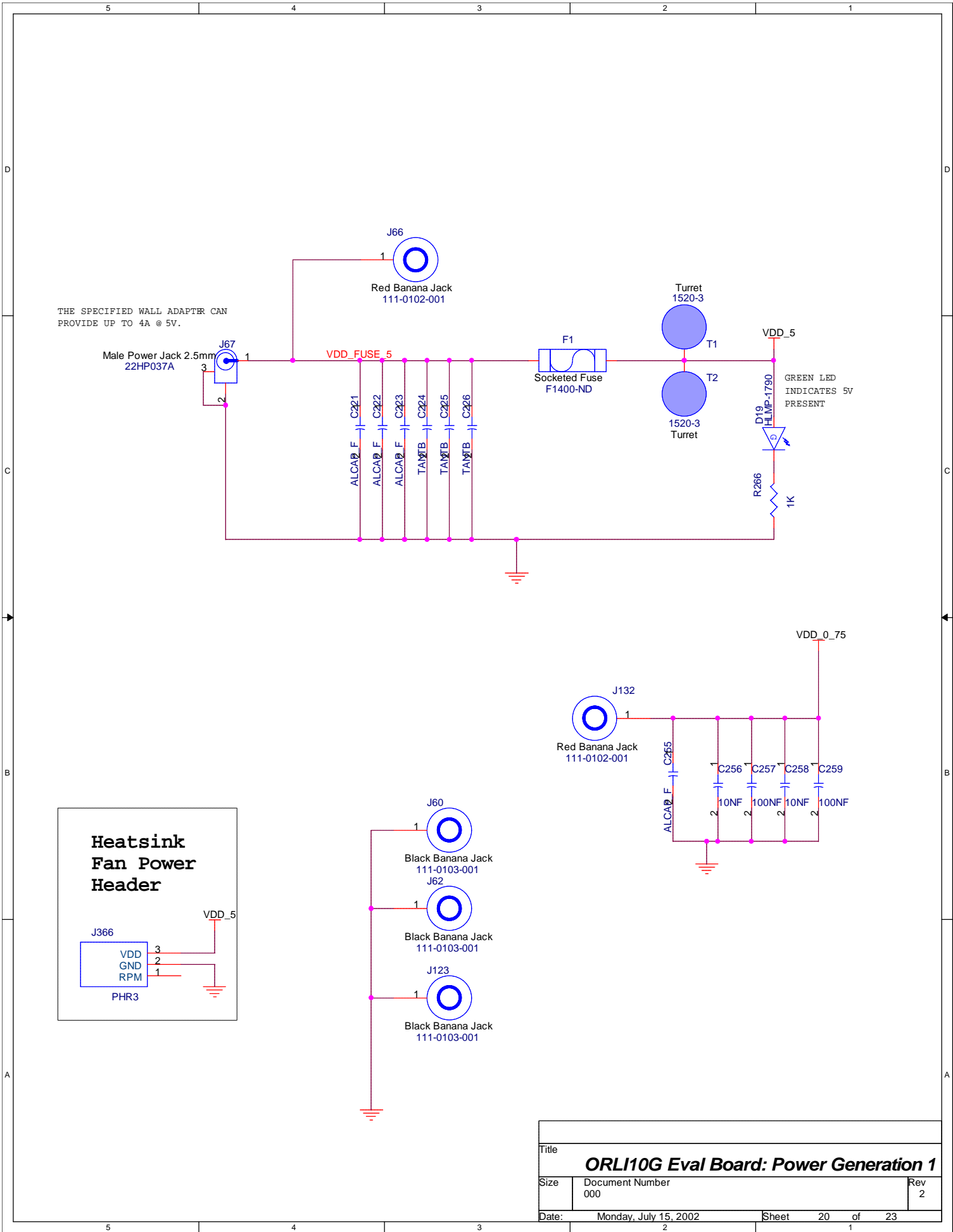

Title		
ORL10G Eval Board: Power Generation 1		
Size	Document Number	Rev
	000	2
Date:	Monday, July 15, 2002	Sheet 20 of 23

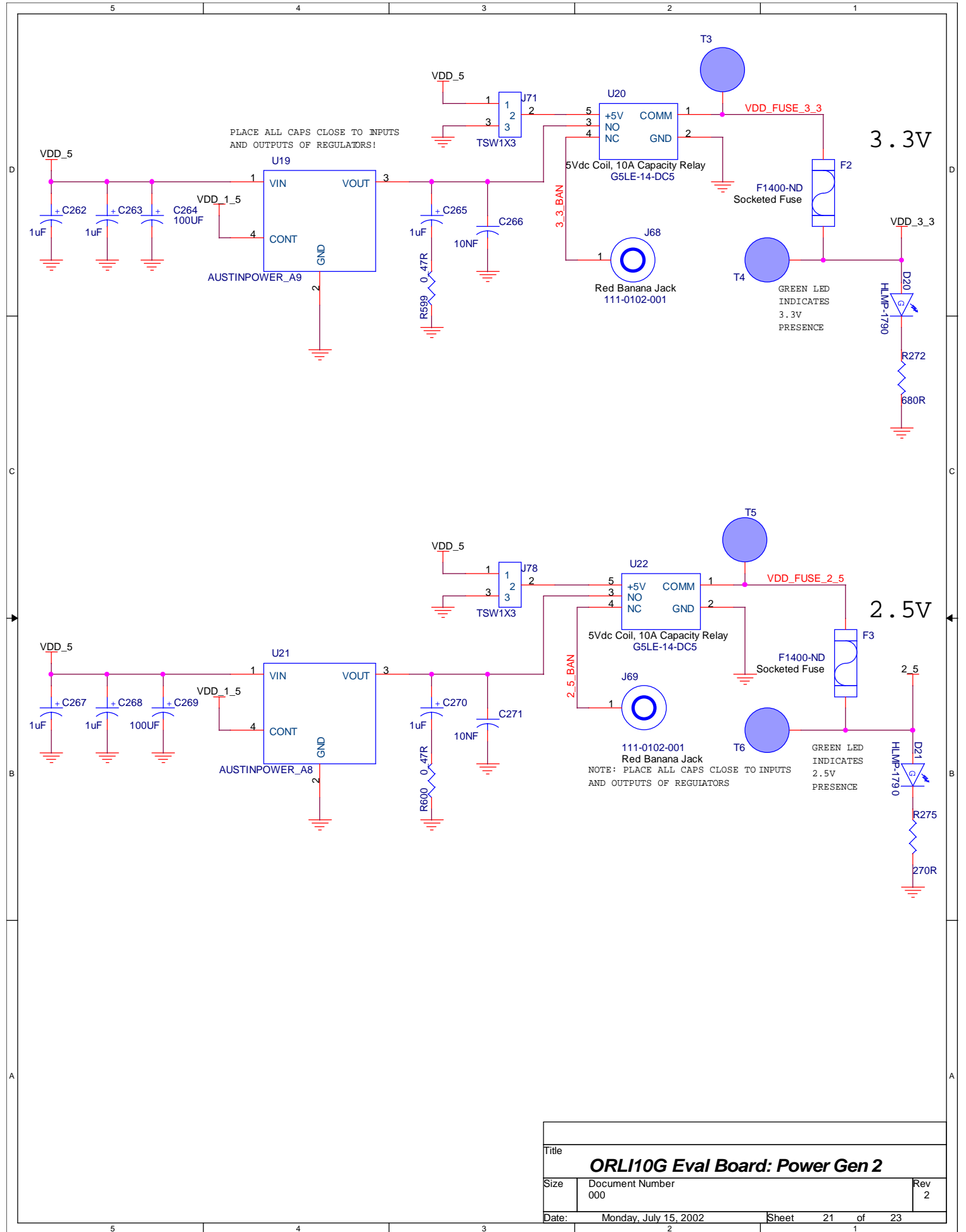

Title		
ORL10G Eval Board: Power Gen 2		
Size	Document Number	Rev
	000	2
Date:	Monday, July 15, 2002	Sheet 21 of 23
	2	1

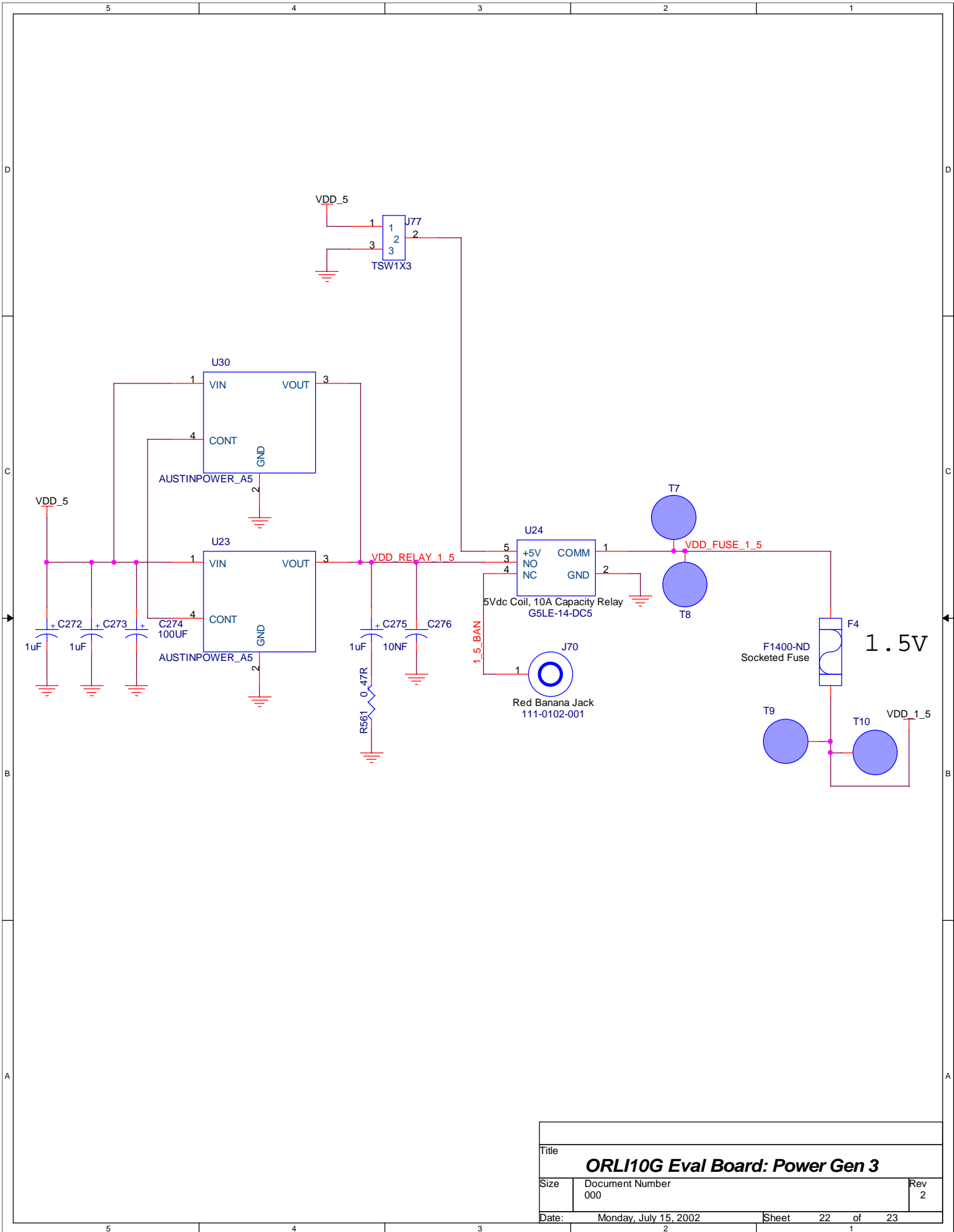

Title		
ORL10G Eval Board: Power Gen 3		
Size	Document Number	Rev
	000	2
Date:	Monday, July 15, 2002	Sheet 22 of 23
	2	1

GENERAL PURPOSE BANANAS

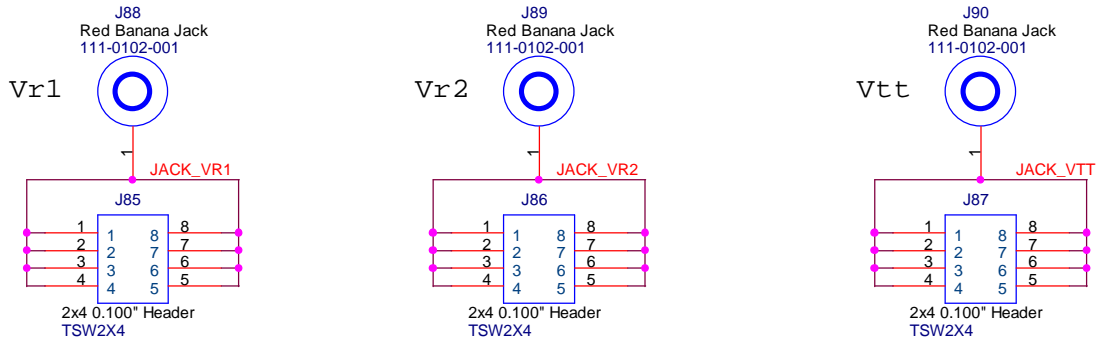

RESISTOR SOCKETS

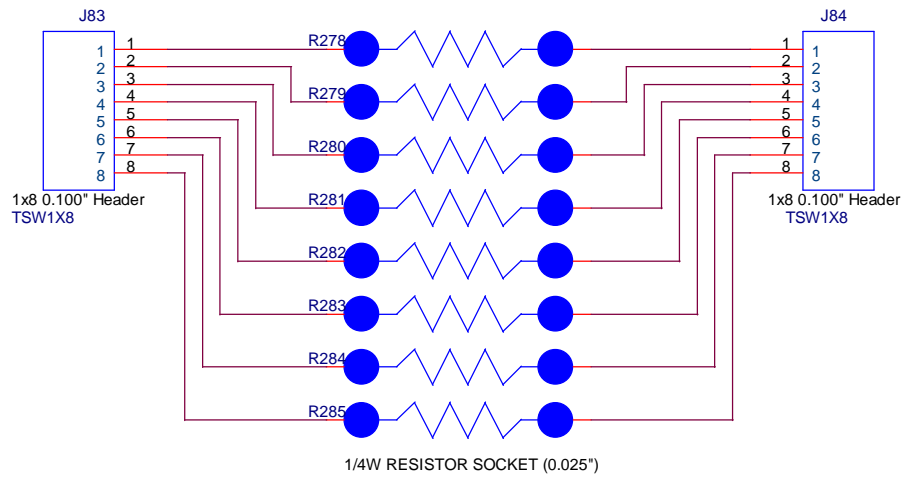

Title		
ORLI10G: Resistor Sockets		
Size	Document Number	Rev
	000	2
Date:	Monday, July 15, 2002	Sheet 23 of 23



Стандарт Электрон Связь

Мы молодая и активно развивающаяся компания в области поставок электронных компонентов. Мы поставляем электронные компоненты отечественного и импортного производства напрямую от производителей и с крупнейших складов мира.

Благодаря сотрудничеству с мировыми поставщиками мы осуществляем комплексные и плановые поставки широчайшего спектра электронных компонентов.

Собственная эффективная логистика и склад в обеспечивает надежную поставку продукции в точно указанные сроки по всей России.

Мы осуществляем техническую поддержку нашим клиентам и предпродажную проверку качества продукции. На все поставляемые продукты мы предоставляем гарантию .

Осуществляем поставки продукции под контролем ВП МО РФ на предприятия военно-промышленного комплекса России , а также работаем в рамках 275 ФЗ с открытием отдельных счетов в уполномоченном банке. Система менеджмента качества компании соответствует требованиям ГОСТ ISO 9001.

Минимальные сроки поставки, гибкие цены, неограниченный ассортимент и индивидуальный подход к клиентам являются основой для выстраивания долгосрочного и эффективного сотрудничества с предприятиями радиоэлектронной промышленности, предприятиями ВПК и научно-исследовательскими институтами России.

С нами вы становитесь еще успешнее!

Наши контакты:

Телефон: +7 812 627 14 35

Электронная почта: sales@st-electron.ru

Адрес: 198099, Санкт-Петербург,
Промышленная ул, дом № 19, литера Н,
помещение 100-Н Офис 331