

# BGA713N7

Single-Band UMTS LNA (700, 800 MHz)

## Data Sheet

Revision 3.1, 2013-01-31

**Edition 2013-01-31**

**Published by  
Infineon Technologies AG  
81726 Munich, Germany**

**© 2013 Infineon Technologies AG  
All Rights Reserved.**

### **Legal Disclaimer**

The information given in this document shall in no event be regarded as a guarantee of conditions or characteristics. With respect to any examples or hints given herein, any typical values stated herein and/or any information regarding the application of the device, Infineon Technologies hereby disclaims any and all warranties and liabilities of any kind, including without limitation, warranties of non-infringement of intellectual property rights of any third party.

### **Information**

For further information on technology, delivery terms and conditions and prices, please contact the nearest Infineon Technologies Office ([www.infineon.com](http://www.infineon.com)).

### **Warnings**

Due to technical requirements, components may contain dangerous substances. For information on the types in question, please contact the nearest Infineon Technologies Office.

Infineon Technologies components may be used in life-support devices or systems only with the express written approval of Infineon Technologies, if a failure of such components can reasonably be expected to cause the failure of that life-support device or system or to affect the safety or effectiveness of that device or system. Life support devices or systems are intended to be implanted in the human body or to support and/or maintain and sustain and/or protect human life. If they fail, it is reasonable to assume that the health of the user or other persons may be endangered.

**BGA713N7 Single-Band UMTS LNA (700, 800 MHz)**

**Revision History: 2013-01-31, Revision 3.1**

**Previous Revision: 2012-10-31, Revision 3.0**

Page	Subjects (major changes since last revision)
25	Footprint recommendation drawing added
26	Marking pattern drawing updated

**Trademarks of Infineon Technologies AG**

AURIX™, C166™, CanPAK™, CIPOS™, CIPURSE™, EconoPACK™, CoolMOS™, CoolSET™, CORECONTROL™, CROSSAVE™, DAVE™, DI-POL™, EasyPIM™, EconoBRIDGE™, EconoDUAL™, EconoPIM™, EconoPACK™, EiceDRIVER™, eupec™, FCOS™, HITFET™, HybridPACK™, I<sup>2</sup>RF™, ISOFACE™, IsoPACK™, MIPAQ™, ModSTACK™, my-d™, NovalithIC™, OptiMOS™, ORIGA™, POWERCODE™, PRIMARION™, PrimePACK™, PrimeSTACK™, PRO-SIL™, PROFET™, RASIC™, ReverSave™, SatRIC™, SIEGET™, SINDRION™, SIPMOS™, SmartLEWIS™, SOLID FLASH™, TEMPFET™, thinQ!™, TRENCHSTOP™, TriCore™.

**Other Trademarks**

Advance Design System™ (ADS) of Agilent Technologies, AMBA™, ARM™, MULTI-ICET™, KEIL™, PRIMECELL™, REALVIEW™, THUMB™, μVision™ of ARM Limited, UK. AUTOSAR™ is licensed by AUTOSAR development partnership. Bluetooth™ of Bluetooth SIG Inc. CAT-iq™ of DECT Forum. COLOSSUS™, FirstGPS™ of Trimble Navigation Ltd. EMV™ of EMVCo, LLC (Visa Holdings Inc.). EPCOS™ of Epcos AG. FLEXGO™ of Microsoft Corporation. FlexRay™ is licensed by FlexRay Consortium. HYPERTERMINAL™ of Hilgraeve Incorporated. IEC™ of Commission Electrotechnique Internationale. IrDA™ of Infrared Data Association Corporation. ISO™ of INTERNATIONAL ORGANIZATION FOR STANDARDIZATION. MATLAB™ of MathWorks, Inc. MAXIM™ of Maxim Integrated Products, Inc. MICROTEC™, NUCLEUS™ of Mentor Graphics Corporation. MIPI™ of MIPI Alliance, Inc. MIPS™ of MIPS Technologies, Inc., USA. muRata™ of MURATA MANUFACTURING CO., MICROWAVE OFFICE™ (MWO) of Applied Wave Research Inc., OmniVision™ of OmniVision Technologies, Inc. Openwave™ Openwave Systems Inc. RED HAT™ Red Hat, Inc. RFMD™ RF Micro Devices, Inc. SIRIUS™ of Sirius Satellite Radio Inc. SOLARIS™ of Sun Microsystems, Inc. SPANSION™ of Spansion LLC Ltd. Symbian™ of Symbian Software Limited. TAIYO YUDEN™ of Taiyo Yuden Co. TEAKLITE™ of CEVA, Inc. TEKTRONIX™ of Tektronix Inc. TOKO™ of TOKO KABUSHIKI KAISHA TA. UNIX™ of X/Open Company Limited. VERILOG™, PALLADIUM™ of Cadence Design Systems, Inc. VLYNQ™ of Texas Instruments Incorporated. VXWORKS™, WIND RIVER™ of WIND RIVER SYSTEMS, INC. ZETEX™ of Diodes Zetex Limited.

Last Trademarks Update 2011-11-11

## Table of Contents

	<b>Table of Contents</b> .....	4
	<b>List of Figures</b> .....	5
	<b>List of Tables</b> .....	6
<b>1</b>	<b>Features</b> .....	7
<b>2</b>	<b>Electrical Characteristics</b> .....	9
2.1	Absolute Maximum Ratings .....	9
2.2	Thermal Resistance .....	9
2.3	ESD Integrity .....	9
2.4	DC Characteristics .....	10
2.5	Band Select / Gain Control Truth Table .....	10
2.6	Switching Time .....	10
2.7	Supply Current and Power Gain Characteristics .....	11
2.8	Logic Signal Characteristics .....	11
2.9	Measured RF Characteristics UMTS Bands XII / XVII .....	12
2.10	Measured RF Characteristics UMTS Bands XIII / XIV .....	13
2.11	Measured RF Characteristics UMTS Band XX .....	14
2.12	Measured Performance Band XIII High Gain Mode vs. Frequency .....	15
2.13	Measured Performance Band XIII High Gain Mode vs. Temperature .....	16
2.14	Measured Performance Band XIII Low Gain Mode vs. Frequency .....	17
2.15	Measured Performance Band XIII Low Gain Mode vs. Temperature .....	18
<b>3</b>	<b>Application Circuit and Block Diagram</b> .....	19
3.1	UMTS Bands XII and XVII Application Circuit Schematic .....	19
3.2	UMTS Bands XIII and XIV Application Circuit Schematic .....	20
3.3	UMTS Bands XX Application Circuit Schematic .....	21
3.4	Pin Description .....	22
3.5	Application Board .....	23
<b>4</b>	<b>Physical Characteristics</b> .....	25
4.1	Package Footprint .....	25
4.2	Package Dimensions .....	26
4.3	Product Marking Pattern .....	26

## List of Figures

Figure 1	Block Diagram of Single-Band LNA . . . . .	8
Figure 2	Application Circuit with Chip Outline (top view) . . . . .	19
Figure 3	Application Circuit with Chip Outline (top view) . . . . .	20
Figure 4	Application Circuit with Chip Outline (top view) . . . . .	21
Figure 5	Application Board Layout on 3-layer FR4 . . . . .	23
Figure 6	Cross-Section view of Application Board . . . . .	23
Figure 7	Detail of Application Board Layout . . . . .	24
Figure 8	Footprint Recommendation 1 for the TSNP-7-1 Package . . . . .	25
Figure 9	Footprint Recommendation 2 for the TSNP-7-1 Package . . . . .	25
Figure 10	Package Outline (top, side and bottom view) . . . . .	26
Figure 11	Tape & Reel Dimensions . . . . .	26
Figure 12	Marking Pattern (top view) . . . . .	26

## List of Tables

Table 1	Absolute Maximum Ratings .....	9
Table 2	Thermal Resistance .....	9
Table 3	ESD Integrity .....	9
Table 4	DC Characteristics, $T_A = 25\text{ °C}$ .....	10
Table 5	Truth Table .....	10
Table 6	Typical switching times; $T_A = -30 \dots 85\text{ °C}$ .....	10
Table 7	Typical Characteristics 700 MHz Band, $T_A = 25\text{ °C}$ , $V_{CC} = 2.8\text{ V}$ , $R_{REF} = 5.6\text{ k}\Omega$ .....	12
Table 8	Typical Characteristics 700 MHz Band, $T_A = 25\text{ °C}$ , $V_{CC} = 2.8\text{ V}$ , $R_{REF} = 5.6\text{ k}\Omega$ .....	13
Table 9	Typical Characteristics 800 MHz Band, $T_A = 25\text{ °C}$ , $V_{CC} = 2.8\text{ V}$ , $R_{REF} = 5.6\text{ k}\Omega$ .....	14
Table 10	Parts List .....	19
Table 11	Parts List .....	20
Table 12	Parts List .....	21
Table 13	Pin Definition and Function .....	22

## 1 Features

Main features:

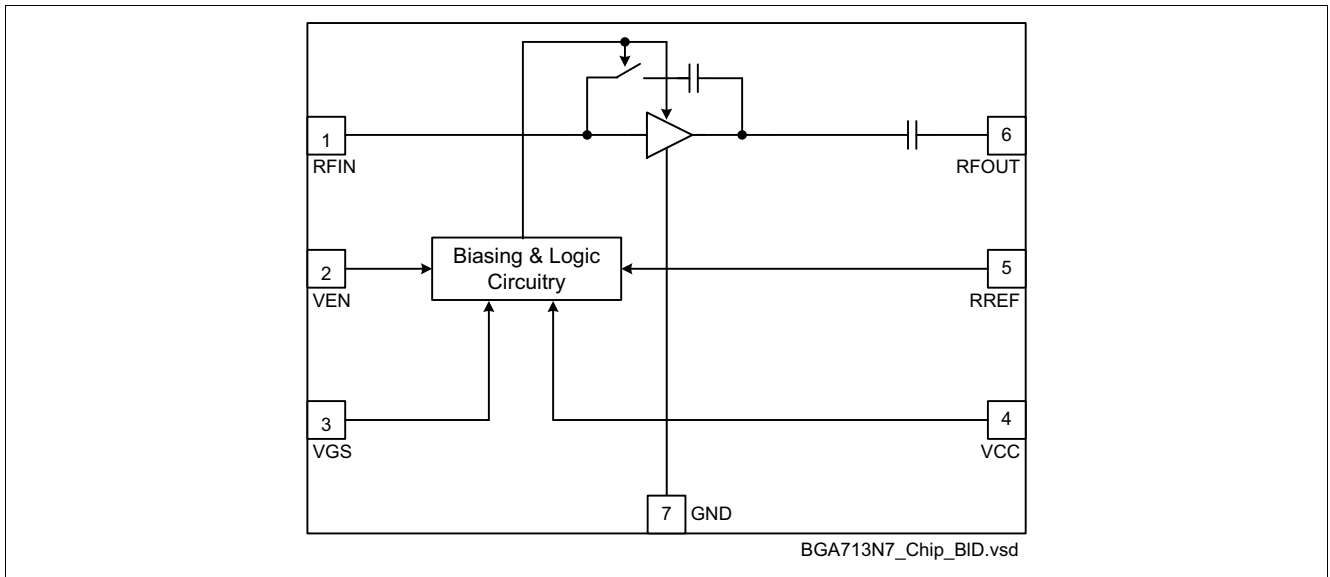
- Gain: 15.5 / -10 dB in high / low gain mode
- Noise figure: 1.1 dB in high gain mode
- Supply current: 4.8 / 0.5 mA in high / low gain mode
- Standby mode (< 2  $\mu$ A typ.)
- Output internally matched to 50  $\Omega$
- Inputs pre-matched to 50  $\Omega$
- 2 kV HBM ESD protection
- Low external component count
- Small leadless TSNP-7-1 package (2.0 x 1.3 x 0.39 mm)
- Pb-free (RoHS compliant) package



### Description

The BGA713N7 is a low current single-band low noise amplifier MMIC for UMTS bands XII, XIII, XIV, XVII and XX. The LNA is based upon Infineon's proprietary and cost-effective SiGe:C technology and comes in a low profile TSNP-7-1 leadless green package. This document specifies electrical parameters, pinout, application circuit and packaging of the chip.

Product Name	Package	Chip	Marking
BGA713N7	TSNP-7-1	T1533	B3



**Figure 1** Block Diagram of Single-Band LNA



## 2 Electrical Characteristics

### 2.1 Absolute Maximum Ratings

**Table 1 Absolute Maximum Ratings**

Parameter	Symbol	Values			Unit	Note / Test Condition
		Min.	Typ.	Max.		
Supply voltage	$V_{CC}$	-0.3	–	3.6	V	–
Supply current	$I_{CC}$	–	–	10	mA	–
Pin voltage	$V_{PIN}$	-0.3	–	$V_{CC}+0.3$	V	All pins except RF input pins
Pin voltage RF input pins	$V_{RFIN}$	-0.3	–	0.9	V	–
RF input power	$P_{RFIN}$	–	–	4	dBm	–
Junction temperature	$T_j$	–	–	150	°C	–
Ambient temperature range	$T_A$	-30	–	85	°C	–
Storage temperature range	$T_{stg}$	-65	–	150	°C	–

**Attention: Stresses above the max. values listed here may cause permanent damage to the device. Exposure to absolute maximum rating conditions for extended periods may affect device reliability. Maximum ratings are absolute ratings; exceeding only one of these values may cause irreversible damage to the integrated circuit.**

### 2.2 Thermal Resistance

**Table 2 Thermal Resistance**

Parameter	Symbol	Values			Unit	Note / Test Condition
		Min.	Typ.	Max.		
Thermal resistance junction to soldering point	$R_{thJS}$	–	150	–	K/W	–

### 2.3 ESD Integrity

**Table 3 ESD Integrity**

Parameter	Symbol	Values			Unit	Note / Test Condition
		Min.	Typ.	Max.		
ESD hardness HBM <sup>1)</sup>	$V_{ESD-HBM}$	–	2000	–	V	All pins

1) According to JESD22-A114

## 2.4 DC Characteristics

**Table 4 DC Characteristics,  $T_A = 25\text{ °C}$**

Parameter	Symbol	Values			Unit	Note / Test Condition
		Min.	Typ.	Max.		
Supply voltage	$V_{CC}$	2.6	2.8	3.0	V	–
Supply current high gain mode	$I_{CCHG}$	–	4.8	–	mA	–
Supply current low gain mode	$I_{CCLG}$	–	0.50	–	mA	–
Supply current standby mode	$I_{CCOFF}$	–	0.1	–	$\mu\text{A}$	–
Logic level high	$V_{HI}$	1.5	2.8	–	V	All logic pins
Logic level low	$V_{LO}$	–	0.0	0.5	V	
Logic currents	$I_{HI}$	–	5.0	–	$\mu\text{A}$	All logic pins
	$I_{LO}$	–	0.1	–	$\mu\text{A}$	

## 2.5 Band Select / Gain Control Truth Table

**Table 5 Truth Table**

Control Voltage		State	
		Bands XII, XIII, XIV, XVII and XX	
VEN	VGS	HG	LG
H	L	OFF	ON
H	H	ON	OFF
L	L	STANDBY <sup>1)</sup>	
L	H		

1) In order to achieve minimum standby current it is encouraged to apply logic low-level at the VGS pin in standby mode although this is not mandatory.

## 2.6 Switching Time

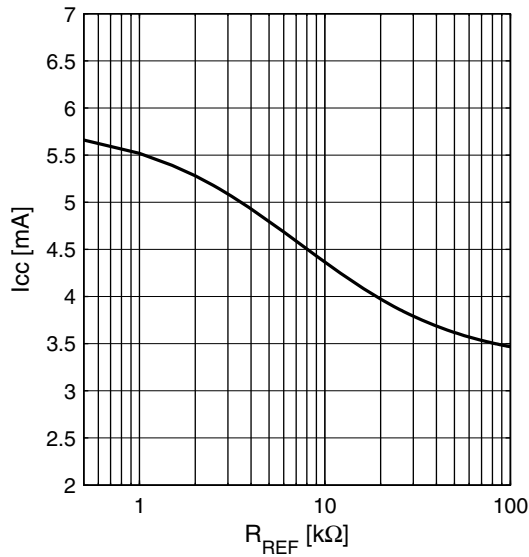
**Table 6 Typical switching times;  $T_A = -30 \dots 85\text{ °C}$**

Parameter	Symbol	Values			Unit	Note / Test Condition
		Min.	Typ.	Max.		
Settling time gainstep	$t_{GS}$	–	1	–	$\mu\text{s}$	Switching LG $\leftrightarrow$ HG

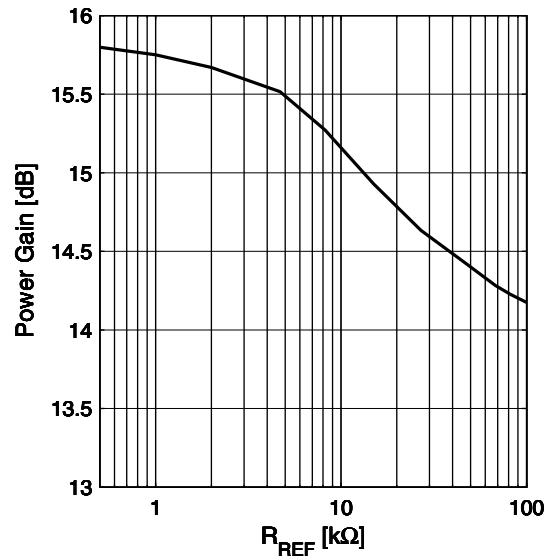
## 2.7 Supply Current and Power Gain Characteristics

Supply current high gain mode versus resistance of reference resistor  $R_{REF}$  see Figure 3 on Page 20; low gain mode supply current is independent of reference resistor).

**Supply Current**  $I_{CC} = f(R_{REF})$   
 $V_{CC} = 2.8\text{ V}$



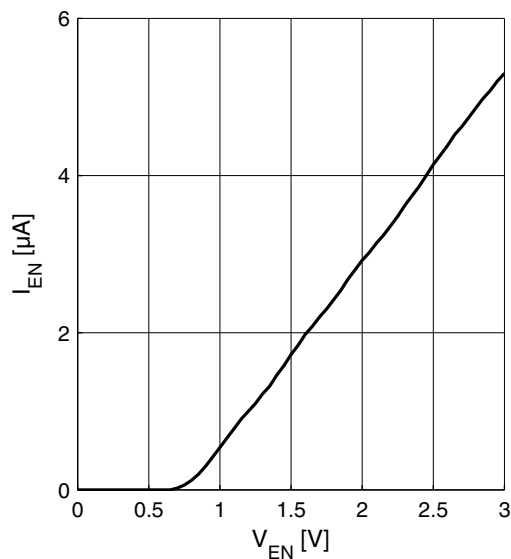
**Power Gain**  $|S_{21}| = f(R_{REF})$   
 $V_{CC} = 2.8\text{ V}$



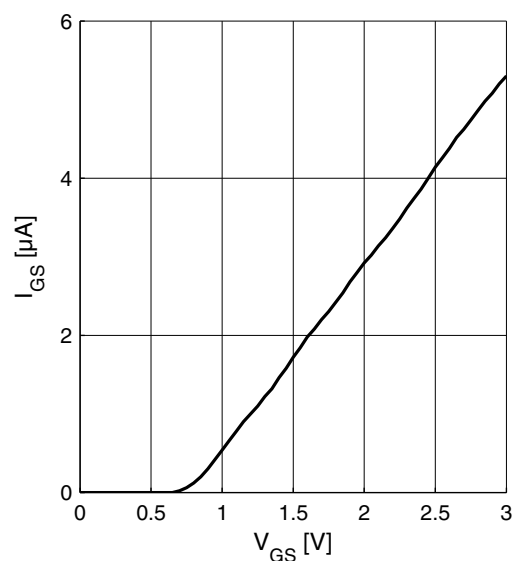
## 2.8 Logic Signal Characteristics

Current consumption of logic inputs VEN, VGS

**Logic currents**  $I_{EN} = f(V_{EN})$   
 $V_{CC} = 2.8\text{ V}$



**Logic currents**  $I_{GS} = f(V_{GS})$   
 $V_{CC} = 2.8\text{ V}$



## 2.9 Measured RF Characteristics UMTS Bands XII / XVII

**Table 7** Typical Characteristics 700 MHz Band,  $T_A = 25\text{ °C}$ ,  $V_{CC} = 2.8\text{ V}$ ,  $R_{REF} = 5.6\text{ k}\Omega$ <sup>1)</sup>

Parameter	Symbol	Values			Unit	Note / Test Condition
		Min.	Typ.	Max.		
Pass band range band XII		728		746	MHz	
Pass band range band XVII		734		746	MHz	
Current consumption	$I_{CCHG}$	–	4.8	–	mA	High gain mode
	$I_{CCLG}$	–	0.50	–	mA	Low gain mode
Gain	$S_{21HG}$	–	15.3	–	dB	High gain mode
	$S_{21LG}$	–	-9.9	–	dB	Low gain mode
Reverse isolation <sup>2)</sup>	$S_{12HG}$	–	-40	–	dB	High gain mode
	$S_{12LG}$	–	-9.9	–	dB	Low gain mode
Noise figure	$NF_{HG}$	–	1.1	–	dB	High gain mode
	$NF_{LG}$	–	9.9	–	dB	Low gain mode
Input return loss <sup>2)</sup>	$S_{11HG}$	–	-13	–	dB	50 $\Omega$ , high gain mode
	$S_{11LG}$	–	-14	–	dB	50 $\Omega$ , low gain mode
Output return loss <sup>2)</sup>	$S_{22HG}$	–	-27	–	dB	50 $\Omega$ , high gain mode
	$S_{22LG}$	–	-19	–	dB	50 $\Omega$ , low gain mode
Stability factor <sup>3)</sup>	$k$	–	>2.2	–		DC to 8 GHz; all gain modes
Input compression point <sup>2)</sup>	$IP_{1dBHG}$	–	-7	–	dBm	High gain mode
	$IP_{1dB LG}$	–	-12	–	dBm	Low gain mode
Inband IIP3 <sup>2)</sup> $f_1 - f_2 = 1\text{ MHz}$ $P_{f1} = P_{f2} = -37\text{ dBm}$	$IIP3_{HG}$	–	-8	–	dBm	High gain mode
	$IIP3_{LG}$	–	-2	–	dBm	Low gain mode

1) Performance based on application circuit in Figure 2 on Page 19

2) Verification based on AQL; not 100% tested in production

3) Guaranteed by device design; not tested in production

## 2.10 Measured RF Characteristics UMTS Bands XIII / XIV

**Table 8** Typical Characteristics 700 MHz Band,  $T_A = 25\text{ °C}$ ,  $V_{CC} = 2.8\text{ V}$ ,  $R_{REF} = 5.6\text{ k}\Omega$ <sup>1)</sup>

Parameter	Symbol	Values			Unit	Note / Test Condition
		Min.	Typ.	Max.		
Pass band range band XIII		746		756	MHz	
Pass band range band XIV		758		768	MHz	
Current consumption	$I_{CCHG}$	–	4.8	–	mA	High gain mode
	$I_{CCLG}$	–	0.50	–	mA	Low gain mode
Gain	$S_{21HG}$	–	15.5	–	dB	High gain mode
	$S_{21LG}$	–	-9.8	–	dB	Low gain mode
Reverse isolation <sup>2)</sup>	$S_{12HG}$	–	-39	–	dB	High gain mode
	$S_{12LG}$	–	-9.8	–	dB	Low gain mode
Noise figure	$NF_{HG}$	–	1.1	–	dB	High gain mode
	$NF_{LG}$	–	9.8	–	dB	Low gain mode
Input return loss <sup>2)</sup>	$S_{11HG}$	–	-15	–	dB	50 $\Omega$ , high gain mode
	$S_{11LG}$	–	-12	–	dB	50 $\Omega$ , low gain mode
Output return loss <sup>2)</sup>	$S_{22HG}$	–	-15	–	dB	50 $\Omega$ , high gain mode
	$S_{22LG}$	–	-20	–	dB	50 $\Omega$ , low gain mode
Stability factor <sup>3)</sup>	$k$	–	>2.3	–		DC to 8 GHz; all gain modes
Input compression point <sup>2)</sup>	$IP_{1dBHG}$	–	-7	–	dBm	High gain mode
	$IP_{1dB LG}$	–	-11	–	dBm	Low gain mode
Inband IIP3 <sup>2)</sup> $f_1 - f_2 = 1\text{ MHz}$ $P_{f1} = P_{f2} = -37\text{ dBm}$	$IIP3_{HG}$	–	-7	–	dBm	High gain mode
	$IIP3_{LG}$	–	-2	–	dBm	Low gain mode

1) Performance based on application circuit in Figure 3 on Page 20

2) Verification based on AQL; not 100% tested in production

3) Guaranteed by device design; not tested in production

## 2.11 Measured RF Characteristics UMTS Band XX

**Table 9** Typical Characteristics 800 MHz Band,  $T_A = 25\text{ °C}$ ,  $V_{CC} = 2.8\text{ V}$ ,  $R_{REF} = 5.6\text{ k}\Omega$ <sup>1)</sup>

Parameter	Symbol	Values			Unit	Note / Test Condition
		Min.	Typ.	Max.		
Pass band range		791		821	MHz	
Current consumption	$I_{CCHG}$	–	4.8	–	mA	High gain mode
	$I_{CCLG}$	–	0.50	–	mA	Low gain mode
Gain	$S_{21HG}$	–	15.9	–	dB	High gain mode
	$S_{21LG}$	–	-8.4	–	dB	Low gain mode
Reverse isolation <sup>2)</sup>	$S_{12HG}$	–	-38	–	dB	High gain mode
	$S_{12LG}$	–	-8.4	–	dB	Low gain mode
Noise figure	$NF_{HG}$	–	1.0	–	dB	High gain mode
	$NF_{LG}$	–	8.4	–	dB	Low gain mode
Input return loss <sup>2)</sup>	$S_{11HG}$	–	-16	–	dB	50 $\Omega$ , high gain mode
	$S_{11LG}$	–	-11	–	dB	50 $\Omega$ , low gain mode
Output return loss <sup>2)</sup>	$S_{22HG}$	–	-13	–	dB	50 $\Omega$ , high gain mode
	$S_{22LG}$	–	-27	–	dB	50 $\Omega$ , low gain mode
Stability factor <sup>3)</sup>	$k$	–	>2.3	–		DC to 8 GHz; all gain modes
Input compression point <sup>2)</sup>	$IP_{1dBHG}$	–	-6	–	dBm	High gain mode
	$IP_{1dBLG}$	–	-10	–	dBm	Low gain mode
Inband IIP3 <sup>2)</sup> $f_1 - f_2 = 1\text{ MHz}$ $P_{f1} = P_{f2} = -37\text{ dBm}$	$IIP3_{HG}$	–	-8	–	dBm	High gain mode
	$IIP3_{LG}$	–	-1	–	dBm	Low gain mode

1) Performance based on application circuit in Figure 4 on Page 21

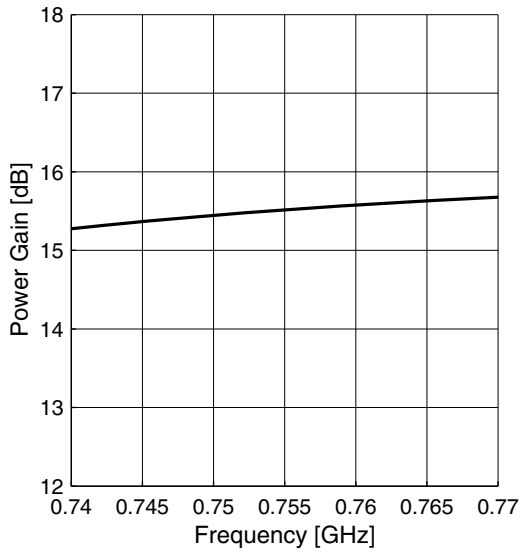
2) Verification based on AQL; not 100% tested in production

3) Guaranteed by device design; not tested in production

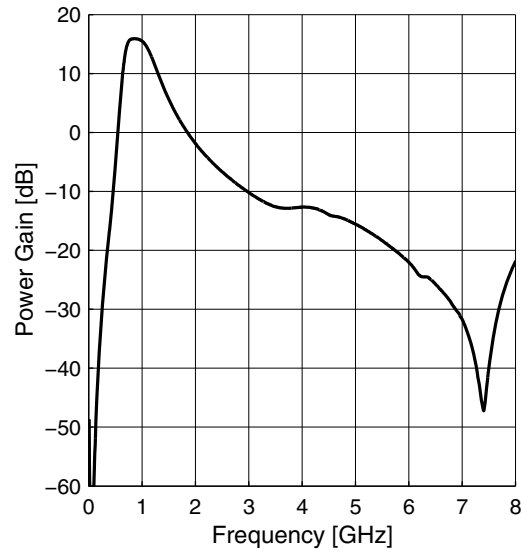
### 2.12 Measured Performance Band XIII High Gain Mode vs. Frequency

$T_A = 25\text{ }^\circ\text{C}$ ,  $V_{CC} = 2.8\text{ V}$ ,  $V_{GS} = 2.8\text{ V}$ ,  $V_{EN} = 2.8\text{ V}$ ,  $R_{REF} = 5.6\text{ k}\Omega$

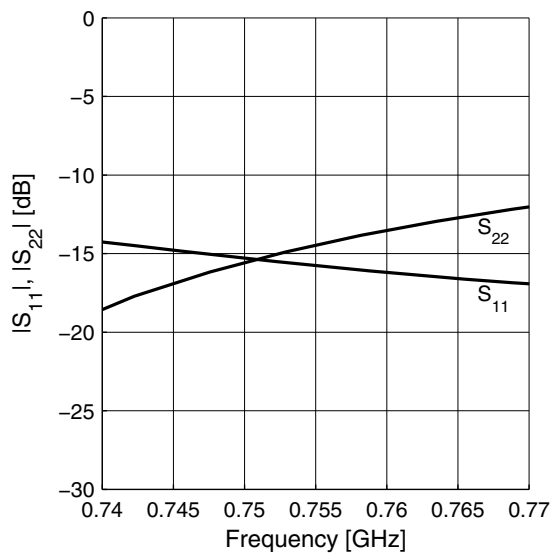
Power Gain  $|S_{21}| = f(f)$



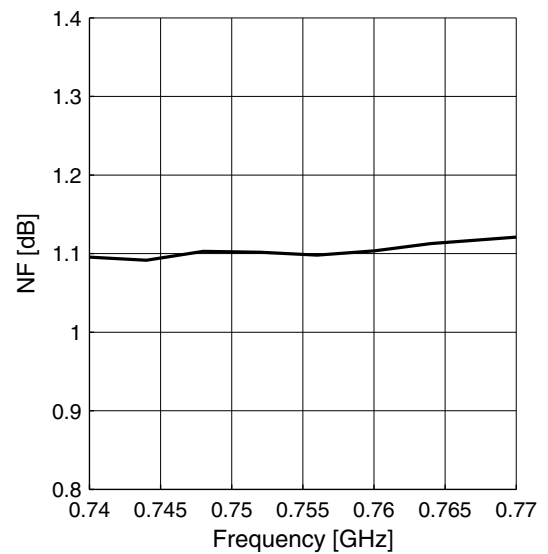
Power Gain wideband  $|S_{21}| = f(f)$



Matching  $|S_{11}| = f(f)$ ,  $|S_{22}| = f(f)$



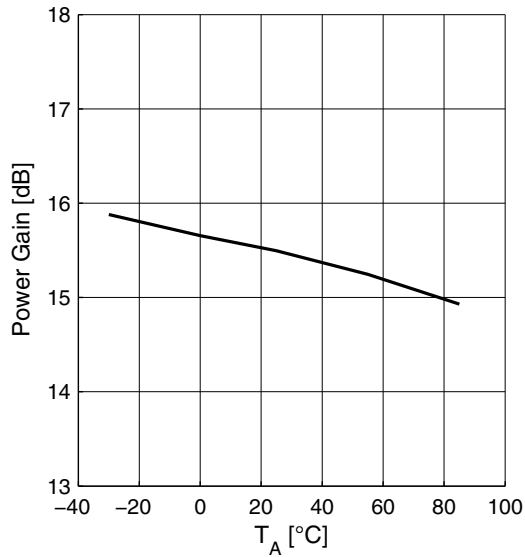
Noise Figure  $NF = f(f)$



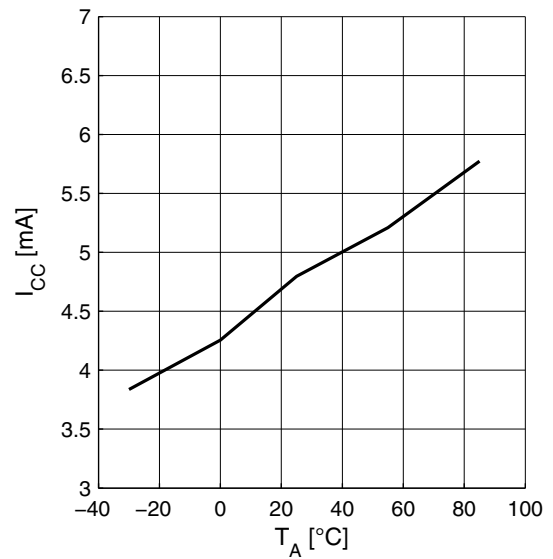
### 2.13 Measured Performance Band XIII High Gain Mode vs. Temperature

$V_{CC} = 2.8\text{ V}$ ,  $V_{GS} = 2.8\text{ V}$ ,  $V_{EN} = 2.8\text{ V}$ ,  $f = 750\text{ MHz}$ ,  $R_{REF} = 5.6\text{ k}\Omega$

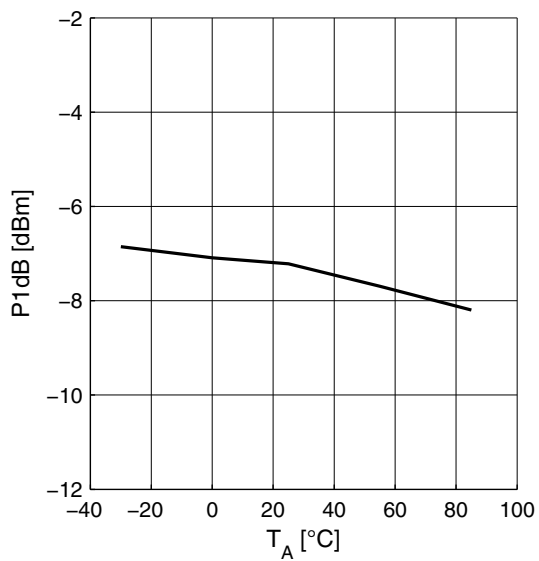
**Power Gain**  $|S_{21}| = f(T_A)$



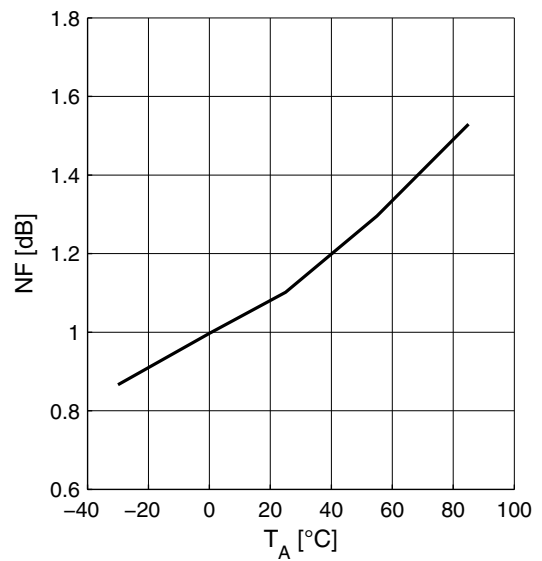
**Supply Current**  $I_{CC} = f(T_A)$



**Input Compression**  $P1dB = f(T_A)$



**Noise Figure**  $NF = f(T_A)$

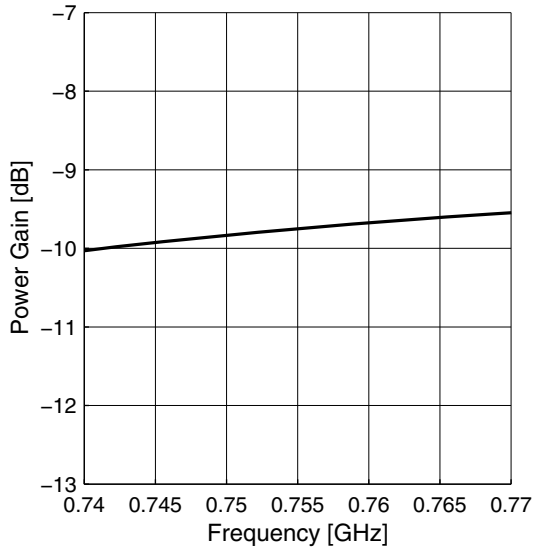




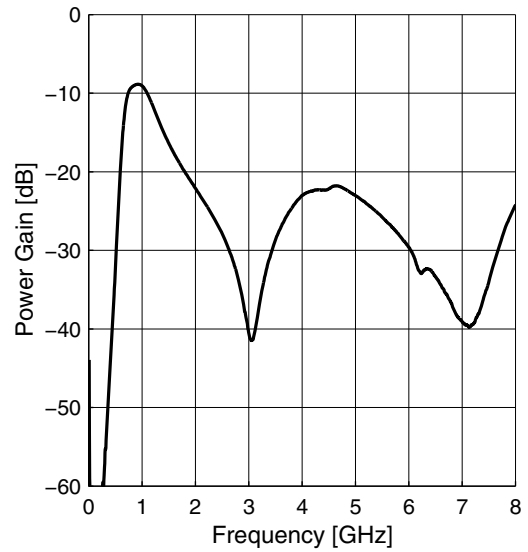
**2.14 Measured Performance Band XIII Low Gain Mode vs. Frequency**

$T_A = 25\text{ }^\circ\text{C}$ ,  $V_{CC} = 2.8\text{ V}$ ,  $V_{GS} = 0\text{ V}$ ,  $V_{EN} = 2.8\text{ V}$ ,  $R_{REF} = 5.6\text{ k}\Omega$

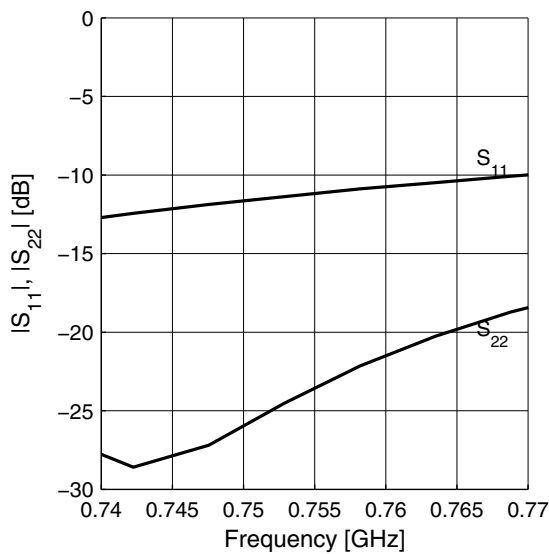
**Power Gain  $|S_{21}| = f(f)$**



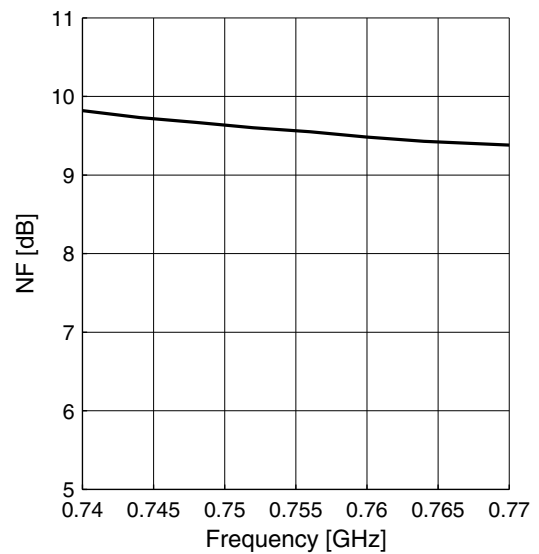
**Power Gain wideband  $|S_{21}| = f(f)$**



**Matching  $|S_{11}| = f(f)$ ,  $|S_{22}| = f(f)$**



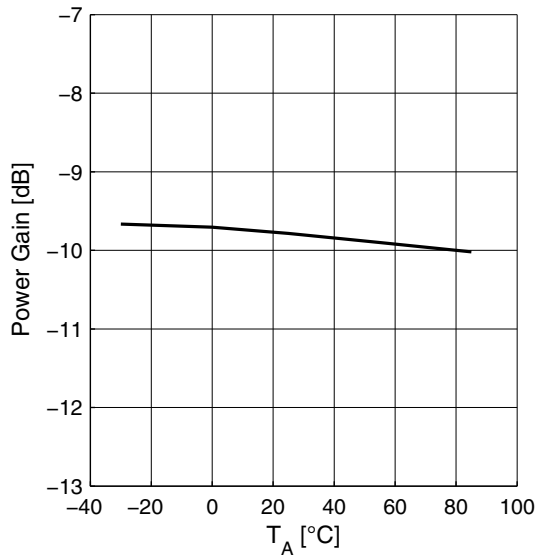
**Noise Figure  $NF = f(f)$**



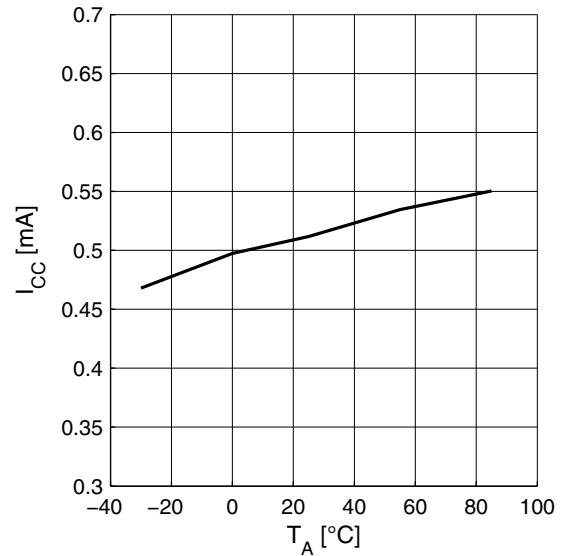
### 2.15 Measured Performance Band XIII Low Gain Mode vs. Temperature

$V_{CC} = 2.8\text{ V}$ ,  $V_{GS} = 0\text{ V}$ ,  $V_{EN} = 2.8\text{ V}$ ,  $f = 750\text{ MHz}$ ,  $R_{REF} = 5.6\text{ k}\Omega$

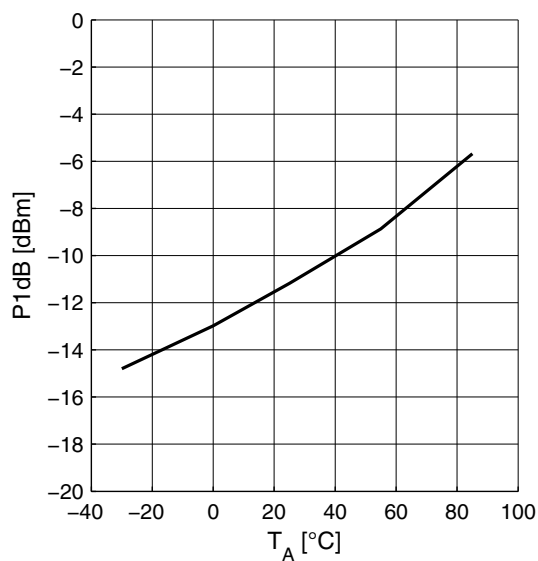
Power Gain  $|S_{21}| = f(T_A)$



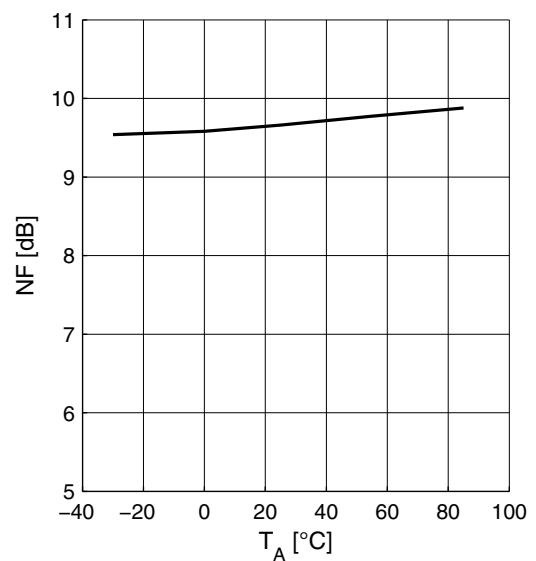
Supply Current  $I_{CC} = f(T_A)$



Input Compression  $P1dB = f(T_A)$

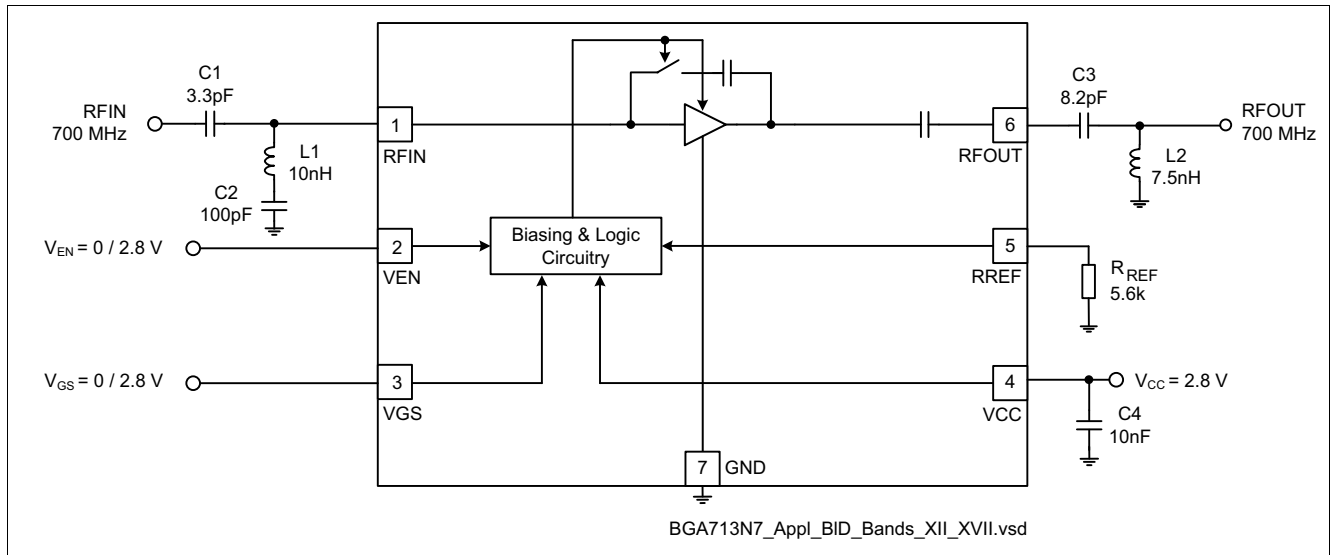


Noise Figure  $NF = f(T_A)$



### 3 Application Circuit and Block Diagram

#### 3.1 UMTS Bands XII and XVII Application Circuit Schematic



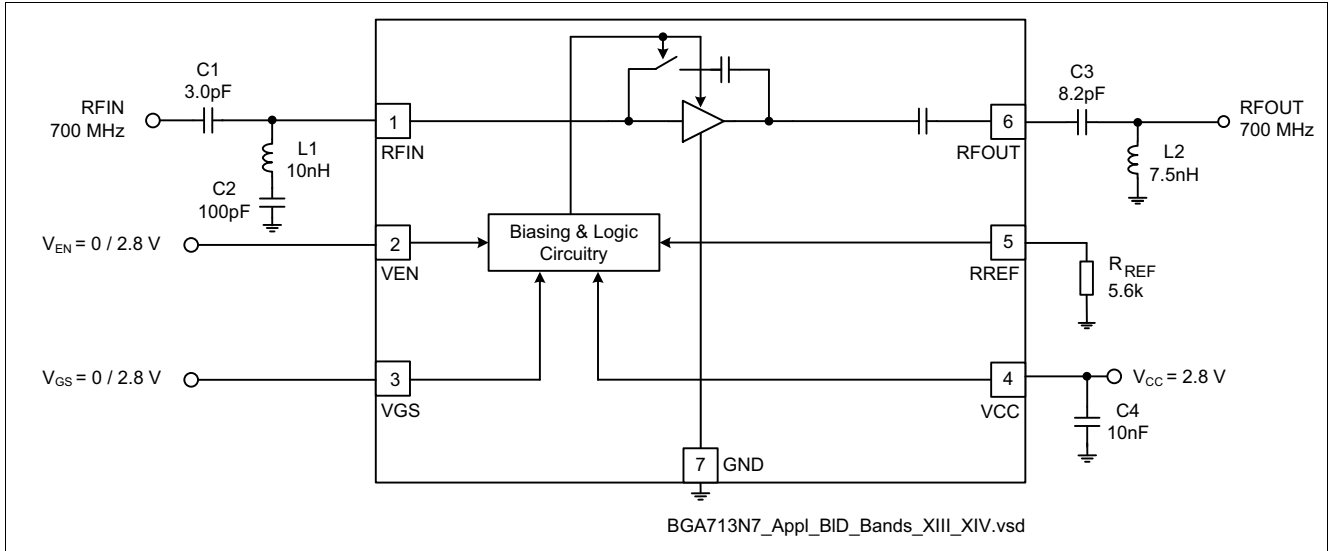
**Figure 2 Application Circuit with Chip Outline (top view)**

*Note: Package paddle (Pin 7) has to be RF grounded.*

**Table 10 Parts List**

Part Number	Part Type	Manufacturer	Size	Comment
L1 ... L2	Chip inductor	Various	0402	Wirewound, $Q \approx 50$
C1 ... C4	Chip capacitor	Various	0402	
RREF	Chip resistor	Various	0402	

### 3.2 UMTS Bands XIII and XIV Application Circuit Schematic



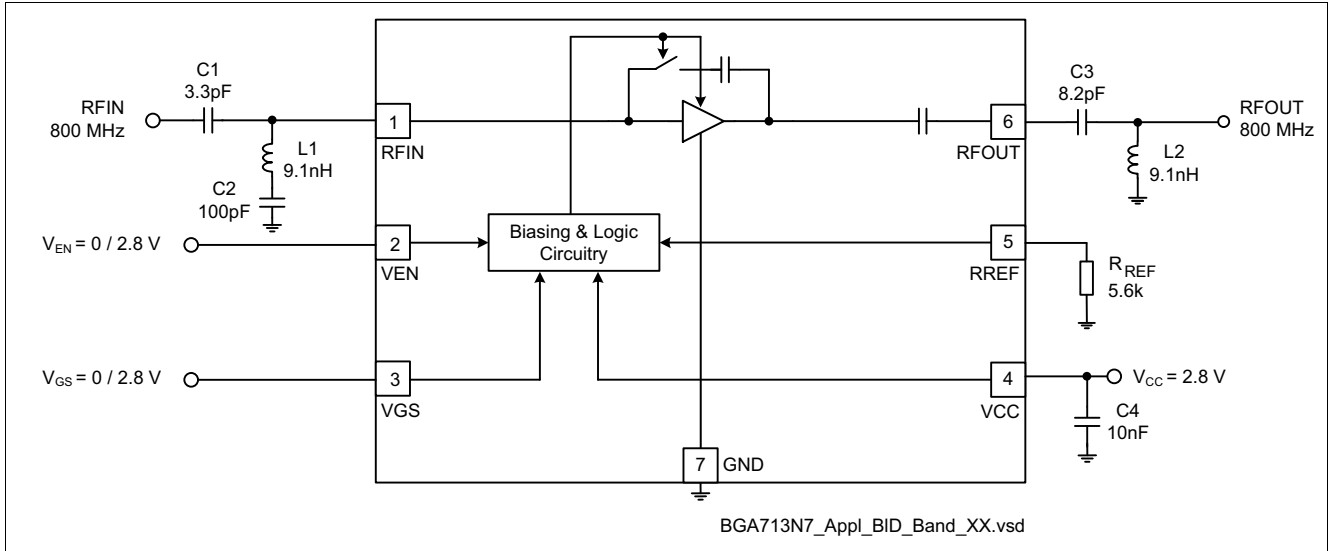
**Figure 3 Application Circuit with Chip Outline (top view)**

*Note: Package paddle (Pin 7) has to be RF grounded.*

**Table 11 Parts List**

Part Number	Part Type	Manufacturer	Size	Comment
L1 ... L2	Chip inductor	Various	0402	Wirewound, $Q \approx 50$
C1 ... C4	Chip capacitor	Various	0402	
RREF	Chip resistor	Various	0402	

### 3.3 UMTS Bands XX Application Circuit Schematic



**Figure 4 Application Circuit with Chip Outline (top view)**

*Note: Package paddle (Pin 7) has to be RF grounded.*

**Table 12 Parts List**

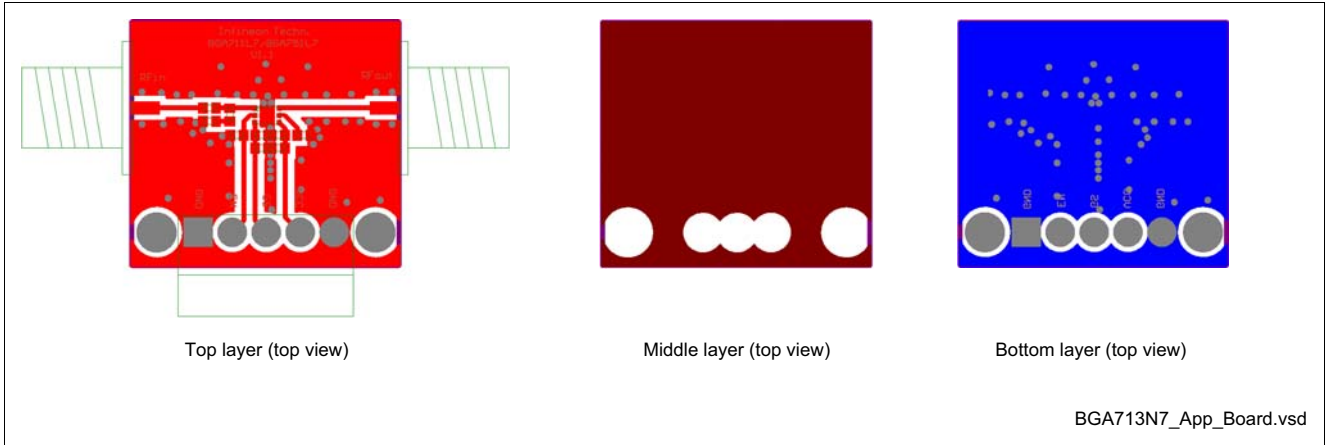
Part Number	Part Type	Manufacturer	Size	Comment
L1 ... L2	Chip inductor	Various	0402	Wirewound, $Q \approx 50$
C1 ... C4	Chip capacitor	Various	0402	
RREF	Chip resistor	Various	0402	

### 3.4 Pin Description

**Table 13 Pin Definition and Function**

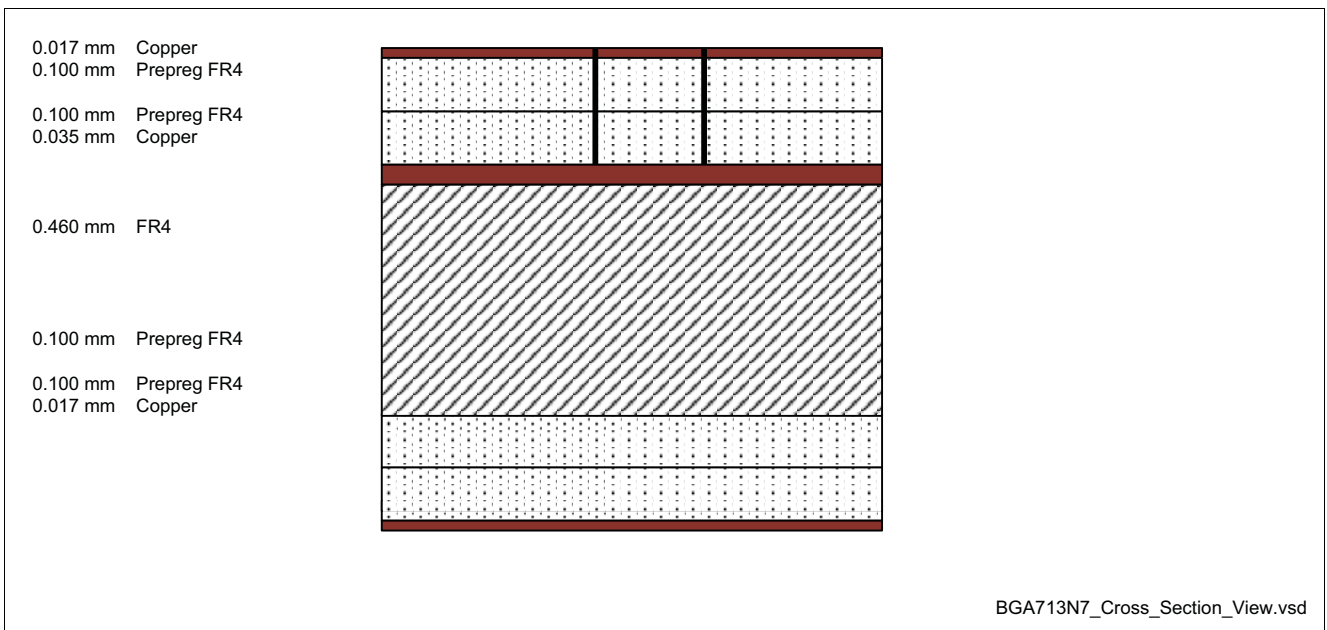
Pin No.	Name	Pin Type	Buffer Type	Function
1	RFIN			LNA input
2	VEN			Band select control
3	VGS			Gain step control
4	VCC			Supply voltage
5	RREF			Bias current reference resistor (high gain mode)
6	RFOUT			LNA output
7	GND			Ground Package paddle; ground connection and control circuitry

### 3.5 Application Board

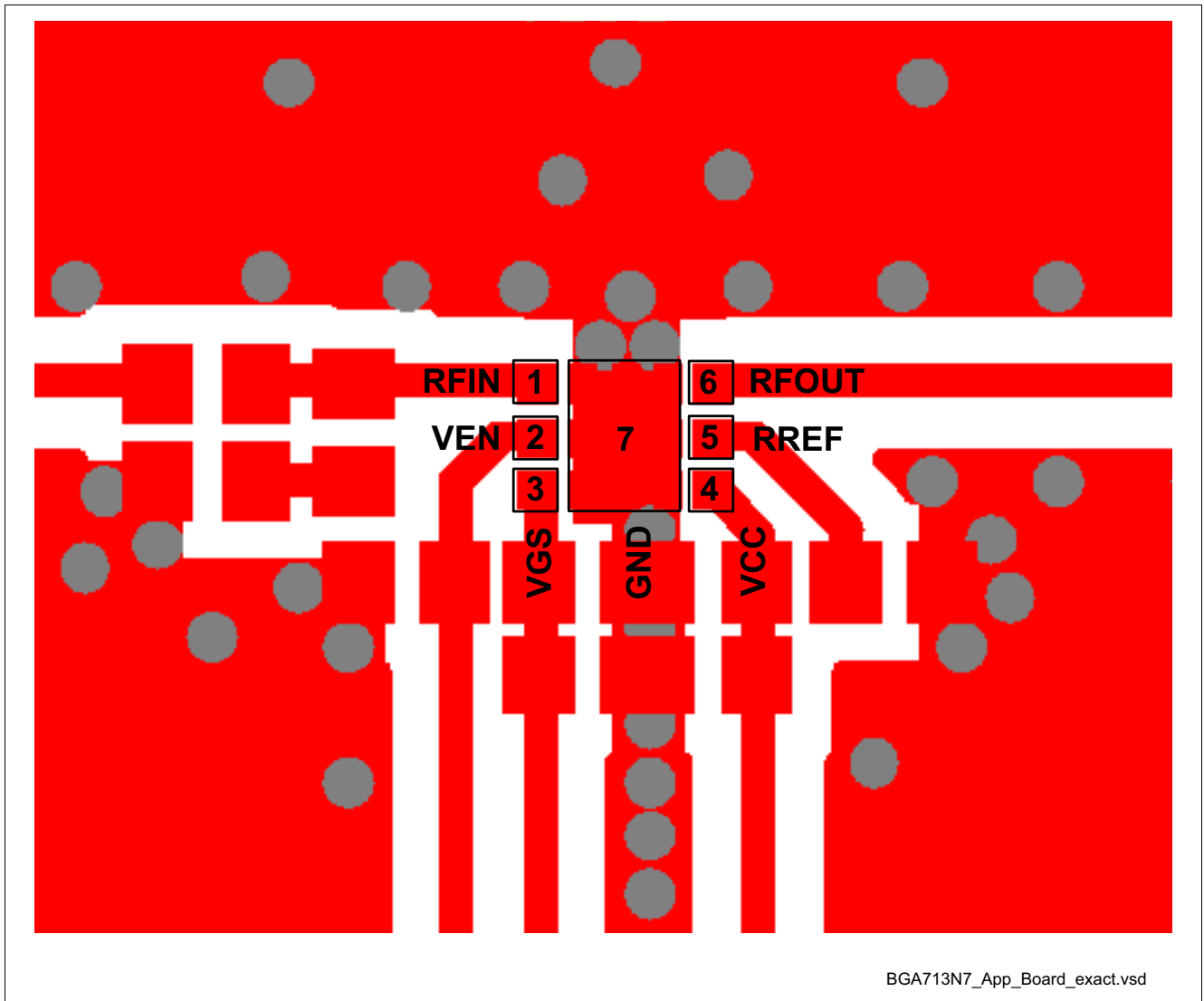


**Figure 5 Application Board Layout on 3-layer FR4**

Note: Top layer thickness: 0.2 mm, bottom layer thickness: 0.8 mm, 17 mm Cu metallization, gold plated. Board size: 21 x 18 mm.



**Figure 6 Cross-Section view of Application Board**



**Figure 7** Detail of Application Board Layout

*Note: In order to achieve the same performance as given in this datasheet please follow the suggested PCB-layout as closely as possible. The position of the GND vias is critical for RF performance.*



## 4 Physical Characteristics

### 4.1 Package Footprint

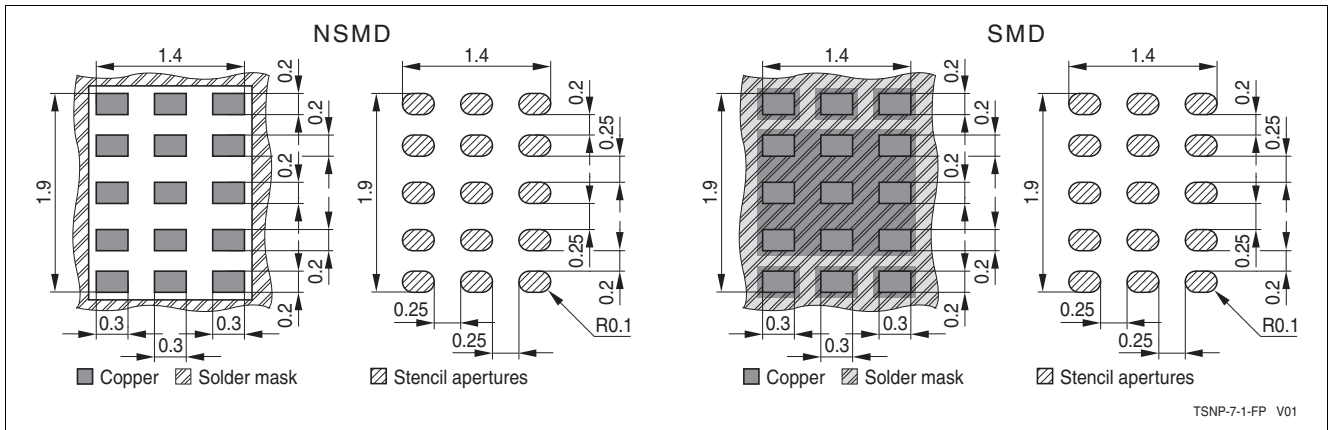


Figure 8 Footprint Recommendation 1 for the TSNP-7-1 Package

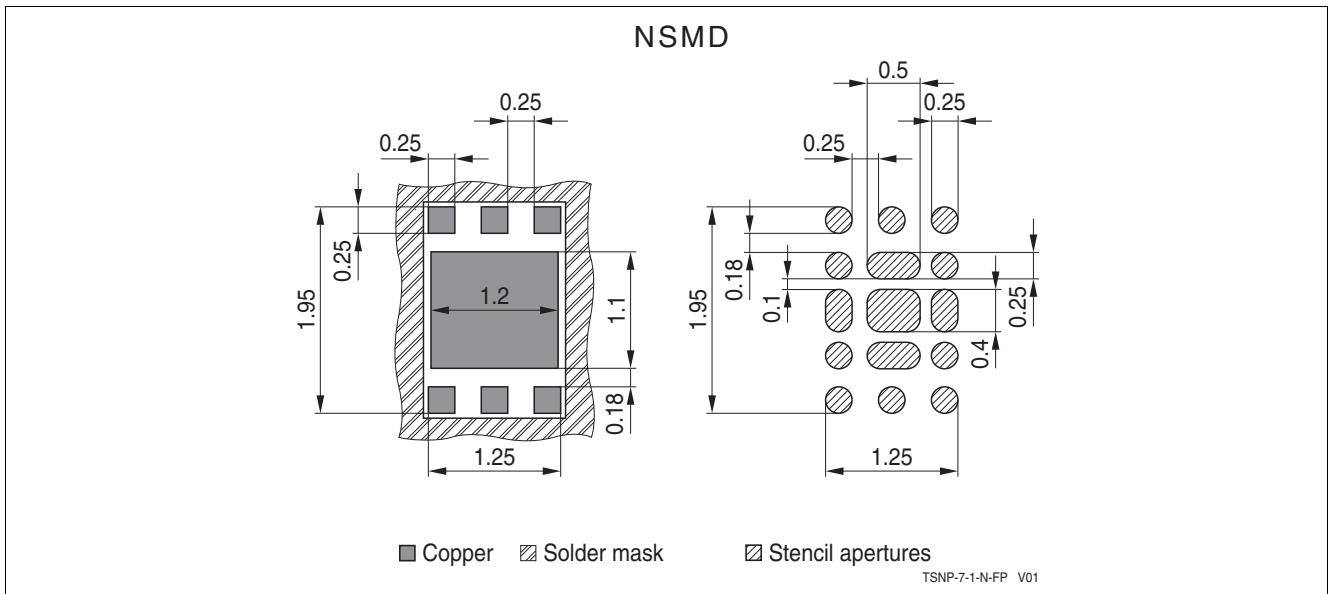
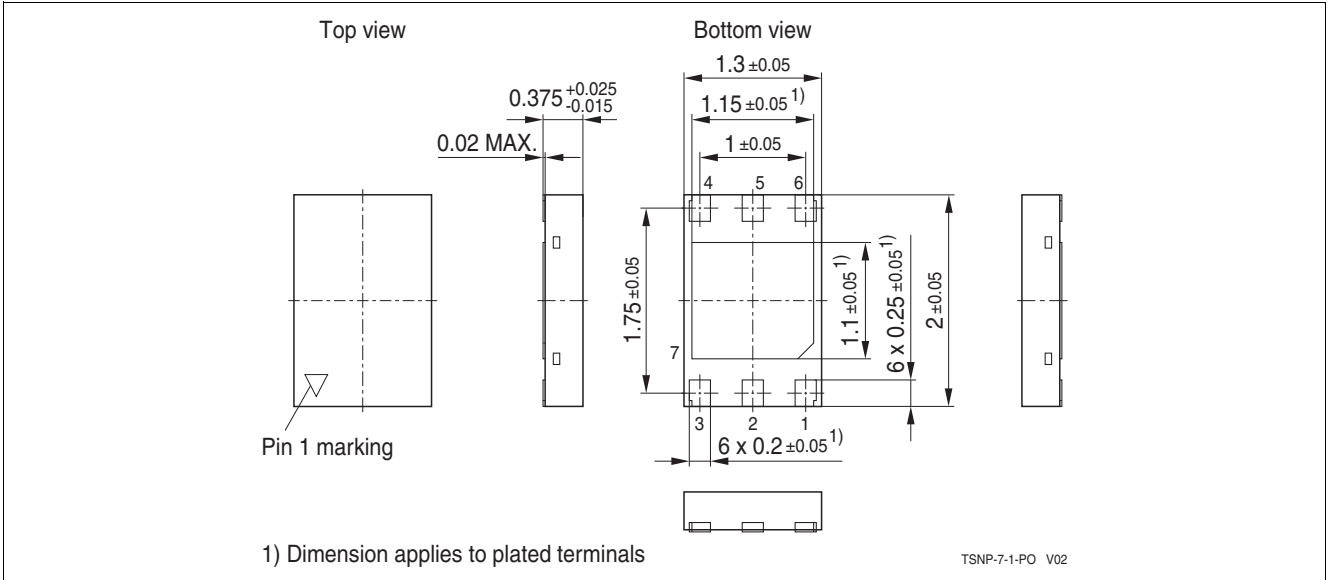
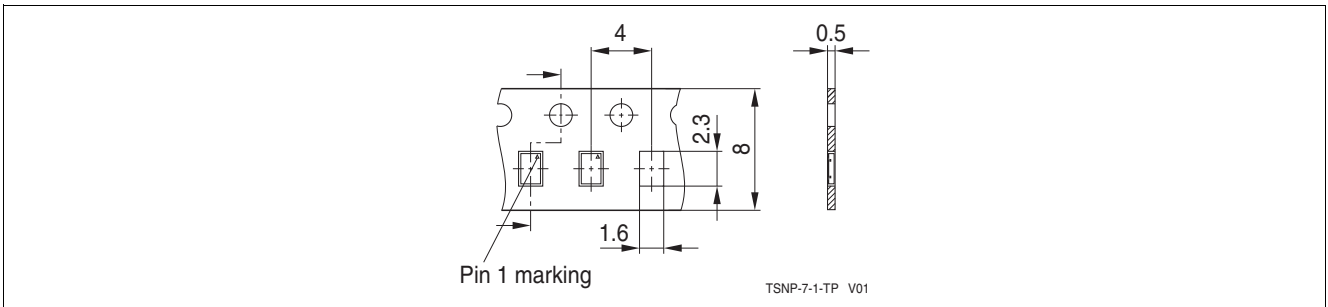


Figure 9 Footprint Recommendation 2 for the TSNP-7-1 Package

## 4.2 Package Dimensions

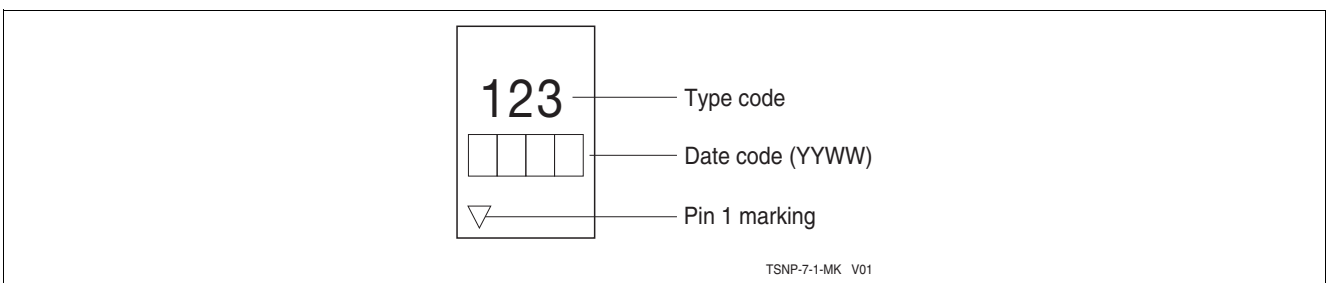


**Figure 10 Package Outline (top, side and bottom view)**



**Figure 11 Tape & Reel Dimensions**

## 4.3 Product Marking Pattern



**Figure 12 Marking Pattern (top view)**

[www.infineon.com](http://www.infineon.com)

Published by Infineon Technologies AG



**Стандарт  
Электрон  
Связь**

Мы молодая и активно развивающаяся компания в области поставок электронных компонентов. Мы поставляем электронные компоненты отечественного и импортного производства напрямую от производителей и с крупнейших складов мира.

Благодаря сотрудничеству с мировыми поставщиками мы осуществляем комплексные и плановые поставки широчайшего спектра электронных компонентов.

Собственная эффективная логистика и склад в обеспечивает надежную поставку продукции в точно указанные сроки по всей России.

Мы осуществляем техническую поддержку нашим клиентам и предпродажную проверку качества продукции. На все поставляемые продукты мы предоставляем гарантию .

Осуществляем поставки продукции под контролем ВП МО РФ на предприятия военно-промышленного комплекса России , а также работаем в рамках 275 ФЗ с открытием отдельных счетов в уполномоченном банке. Система менеджмента качества компании соответствует требованиям ГОСТ ISO 9001.

Минимальные сроки поставки, гибкие цены, неограниченный ассортимент и индивидуальный подход к клиентам являются основой для выстраивания долгосрочного и эффективного сотрудничества с предприятиями радиоэлектронной промышленности, предприятиями ВПК и научно-исследовательскими институтами России.

С нами вы становитесь еще успешнее!

**Наши контакты:**

**Телефон:** +7 812 627 14 35

**Электронная почта:** [sales@st-electron.ru](mailto:sales@st-electron.ru)

**Адрес:** 198099, Санкт-Петербург,  
Промышленная ул, дом № 19, литера Н,  
помещение 100-Н Офис 331