



Qorivva MPC5746R-176DS/252DS Evaluation Board (EVB) User's Guide

by: Bill Terry
32-bit Automotive Applications

1 Introduction

This document describes the Qorivva MPC5746R evaluation board (EVB) for the 176LQFP, the 252MAPBGA, and the 144LQFP packages. The EVB is targeted at providing a platform for the evaluation and development of the MPC5746R automotive MCU, facilitating hardware and software development as well as debugging. Settings for switches, jumpers, LEDs, and push-buttons are shown for basic operation of the prototype version of the EVB.

This document is preliminary and is subject to change without notice.

2 Features

The EVB provides the following primary features listed below:

- Standalone operation or use with the optional MPC57XXXMB main board

Contents

1	Introduction	1
2	Features	1
3	Modular concept	2
4	EVB configuration	3
4.1	Methods of operation	3
4.2	Power source	3
4.3	Clock Configuration Options	5
4.4	Micro Second Channel Connections	5
4.5	ADC Channel Filters	6
4.6	SIPI Interface	7
4.7	JTAG Interface	8
4.8	I/O Connectivity and Port Routing	9
5	Reset switches	14
6	LEDs	14
7	Test points	14
8	EVB Top View	16
9	Schematics	17
10	EVB Errata	17
11	Revision history	17

Modular concept

- Socketed MPC5746R in 176-pin LQFP package, 144-pin LQFP package, or 252MAPBGA package
- Power options
 - Power supplied via the two interface connectors when using the EVB with the optional MPC57XXXMMB main board
 - Power supplied via terminal block when using the EVB in standalone configuration
- Debug and trace
 - debug via JTAG connector
 - Trace using internal trace memory
- Clocks
 - 20 MHz crystal
 - SMA connector for external clock
 - Oscillator
- MicroSecond Channel
 - SAMTECH connector providing easy connection to microsecond channel pins
- I/O connectivity
 - Access to all port pins when using the EVB with the optional MPC57XXXMB main board— Access to SCI, CAN, LIN, and UART physical interfaces when using the EVB with the optional MPC57XXXMB main board
- Switches
 - Power-on reset
- LEDs for power indication
- Test points

3 Modular concept

The MPC5746R-176DS/252DS/144DS is part of a modular EVB hardware system that consists of:

- A common main board that provides power and access to common communication interfaces and the MCU I/O port pins. The MPC5746R-176DS/252DS/144DS is compatible with the MPC57XXXMB main board.
- A package-specific EVB to support all available production package types of the MPC5746R¹.

NOTE

The MPC57XXXMB User Guide should be obtained to provide additional configuration information when used with the MPC5746-xxxDS.

See [Figure 1, “MPC5746R EVB and main board system”](#) for an illustration of the modular EVB hardware system concept.

¹The MPC5746R Emulation Device (ED) requires separate hardware that may be ordered through your Freescale Salesperson or Representative.

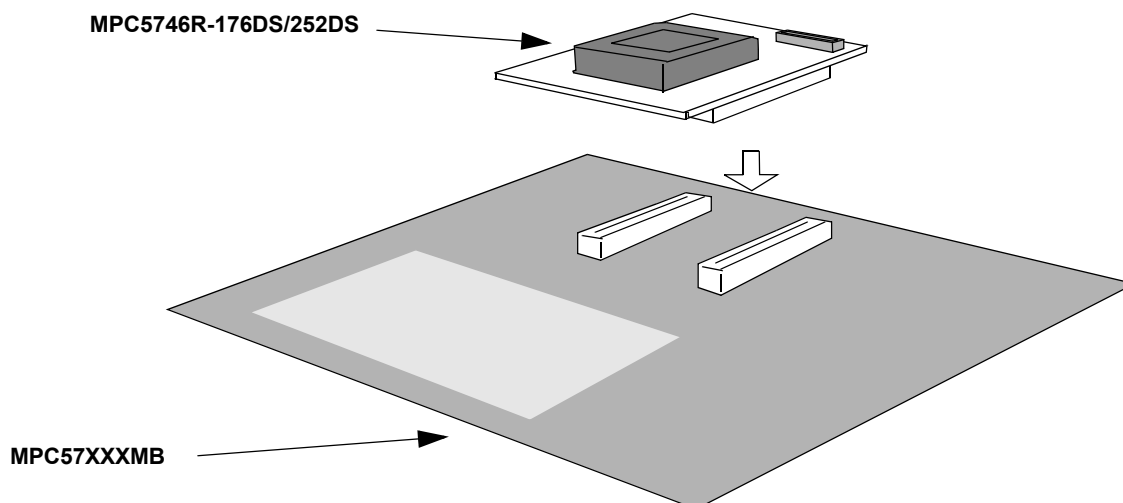

Figure 1. MPC5746R EVB and main board system

4 EVB configuration

This section provides information on how to configure the jumper settings on the EVB. Default settings are marked as such.

4.1 Methods of operation

Power to the EVB is supplied by one of two options:

1. The MPC57XXXMB main board generates the 5 V/3.3 V/1.25 V supplies and provides these to the EVB via the interface connectors.
2. In standalone configuration, external 5 V/3.3 V/1.25 V supplies are provided to the EVB via the terminal block. (This option provides minimal access to I/O)

4.2 Power source

The default jumper settings are configured for using the EVB with the MPC57XXXMB main board. Power is supplied from the main board to the EVB via the two interface connectors.

The EVB can also operate as a standalone device, where power can be supplied from an external power source.

[Table 1](#) summarizes the jumper settings for the available power options.

Table 1. Jumper Settings — Power Options

Jumper	Setting	Description
J23	Choose one: 1-2 ON 2-3 ON	Main IO Voltage Supply - VDD_HV_IO_MAIN 5V supply from motherboard (default) 5V supply from external source

Table 1. Jumper Settings — Power Options (continued)

Jumper	Setting	Description
J19	Choose one: 1-3 ON 7-9 ON 3-4 ON 7-8 ON	Low voltage power select - VDD_LV_SELECT 3.3V mother board supply (default) 5.0V mother board supply 3.3V external supply 5.0V external supply
J18	Choose one: 3-5 ON 3-4 ON 1-3 ON	Low voltage core select - VDD_LV 1.25V external supply 1.25V internal regulator supply 1.25V mother board supply (default)
J22	Choose one: 1-2 ON 2-3 ON	SAR ADC Voltage Supply - VDD_HV_ADV_SAR 5.0V mother board supply (default) 5.0V external supply
J8	Choose one: 1-2 ON 2-3 ON	SD ADC Voltage Supply - VDD_HV_ADV_SD 5.0V mother board supply (default) 5.0V external supply
J3	Choose one: 7-9 ON 1-3 ON 7-8 ON 3-4 ON	High voltage JTAG power - VDD_HV_IO_JTAG 5.0V mother board supply 3.3V mother board supply (default) 5.0V external supply 3.3V external supply
J5	Choose one: 7-9 ON 1-3 ON 3-4 ON 7-8 ON	Microsecond Channel I/O Segment Voltage Supply - VDD_HV_IO_MSC 5.0V mother board supply (default) 3.3V mother board supply 3.3V external supply 5.0V external supply
J20	Choose one: 7-9 ON 1-3 ON 3-4 ON 7-8 ON	Ethernet I/O Segment Voltage Supply - VDD_HV_IO_FEC 5.0V mother board supply 3.3V mother board supply (default) 3.3V external supply 5.0V external supply
J14	Choose one: 1-2 ON 2-3 ON	High voltage PMC supply - VDD_HV_PMC 5.0V motherboard supply (default) 5.0V external supply
J4	Choose one: 7-9 ON 1-3 ON 3-4 ON 7-8 ON 3-5 ON	Standby RAM Supply Input - VDDSTBY 5.0V mother board supply 3.3V mother board supply (default) 3.3V external supply 5.0V external supply GND (default)
J17	Choose one: Installed Removed	BCTRL - On-chip regulator pass transistor control Control enabled Control disabled
J12	Choose one: 1-2 2-3	Oscillator Power - OSC_PWR 3.3V mother board supply (default) 3.3V external supply

If stand alone operation is desired, the following power supplies connections should be made on J6 (see [Table 2](#)). If using the external supplies option, the user should reference the MPC5746R Data Sheet to ensure that IDD requirements for each supply are met.

Table 2. External power input

J6	Description
Pin 1	1.25 V
Pin 2	3.3 V
Pin 3	5 V
Pin 4	GND

4.3 Clock Configuration Options

The EVB provides three clocking options that are controlled by jumpers:

- On board 20 MHz crystal oscillator
- On board oscillator
- SMA connector for external clock source

[Table 3](#) summarizes the jumper settings for the available clock options. Note that some of these jumpers are ‘non-populated’ by default and the clock source is configured by default for crystal oscillator operation.

Table 3. Jumper Settings - Clock Configuration

Jumpers		Selected Clock Source		
Reference Designator	Description	Crystal (default)	Oscillator	SMA
JP2	Shunt to terminate EXTAL with 49.9 ohm resistor to GND	Remove	Remove	Install
JP3	Shunt to connect EXTAL to crystal	Install	Remove	Remove
JP4	Shunt to connect EXTAL to oscillator	Remove	Install	Remove
JP5	Shunt to connect EXTAL to SMA connector	Remove	Remove	Install
JP6	Shunt to connect XTAL to GND	Remove	Install	Install
J10	Oscillator enable	Remove	Install ¹	Remove

¹ If the oscillator is selected as the clock source, check that J12 (see [Table 1](#)) is used to select the desired oscillator power.

4.4 Micro Second Channel Connections

The microsecond channel signals on MSC1 are grouped at a SAMTECH ERF-8 connector on the EVB to provide easier user access. This also allows better trace routing of the differential pair signals. The connections of MSC1 on the connector are shown in [Figure 2](#).

EVB configuration

Note that by default these signals are not routed to the motherboard via the motherboard interface connectors. However, zero ohm resistors may be installed at the reference designators listed in Figure 2 if the signals need to be routed to the motherboard for use as GPIO or other purposes.

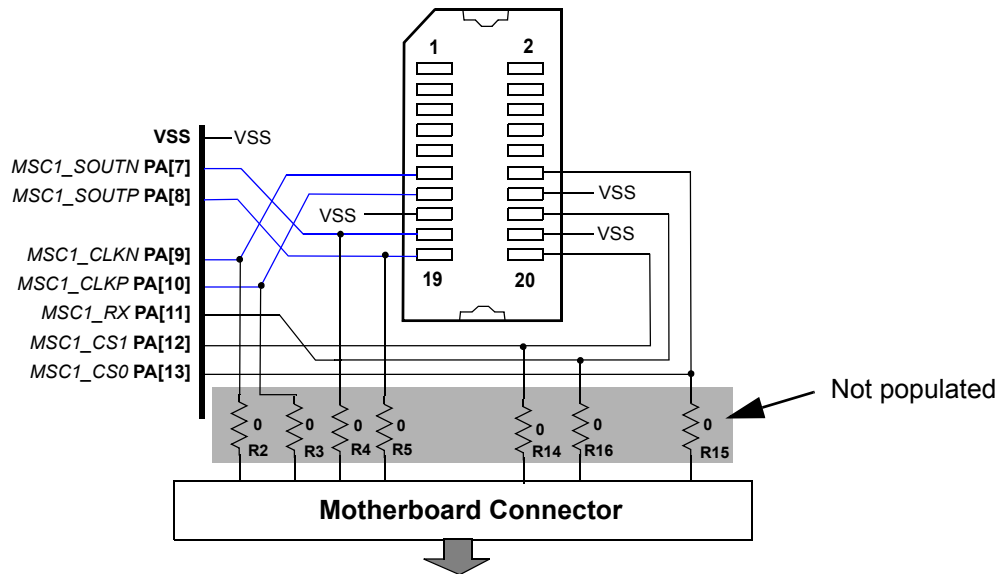

Figure 2. Samtech ERF8 - MSC1 Connections (20-pin)

The following table lists the port and pins associated with each of the MSC channel signals.

Table 4. MSC Signal Mapping

Signal Name		Device Port	Pin Assignment	
			176LQFP	252MAPBGA
MSC1	MSC1_SOUTN	PA7	165	C6
	MSC1_SOUTP	PA8	164	A6
	MSC1_CLKN	PA9	161	A7
	MSC1_CLKP	PA10	160	B7
	MSC1_RX	PA11	159	C7
	MSC1_CS1	PA12	158	B8
	MSC1_CS0	PA13	157	A8

4.5 ADC Channel Filters

For convenience, the EVB implements analog RC filters on one differential ADC channel pair, and two single ended ADC channels. The single ended filter configuration is shown in Figure 3, and the differential pair filter configuration is shown in Figure 4. The user may modify these component values for the desired application.

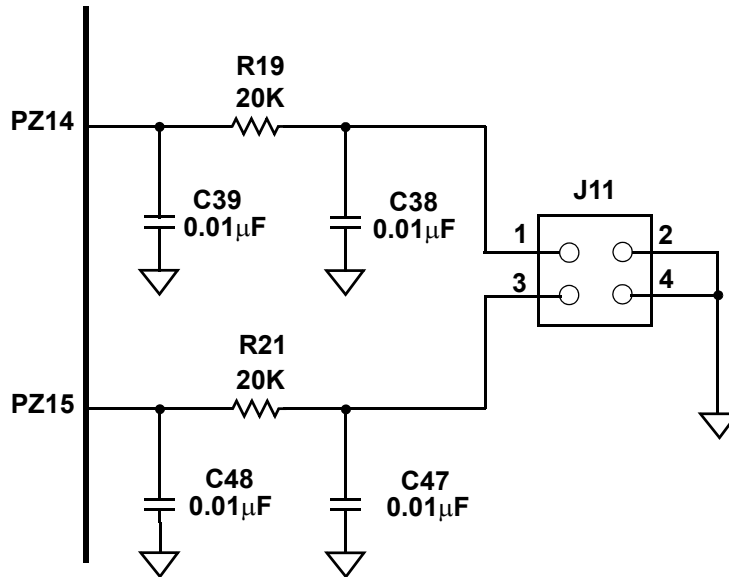

Figure 3. Single Ended ADC Channel Filters

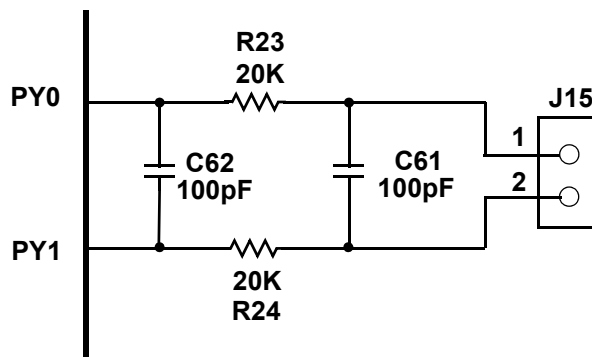

Figure 4. Differential ADC Channel Filter

4.6 SIPI Interface

A SIPI interface is provided on the EVB for high speed interprocessor communications. The SIPI interface connections are shown in [Figure 5](#) and listed in [Table 5](#).

Note: This resistor is near the MCU – not near the SIPI connector.

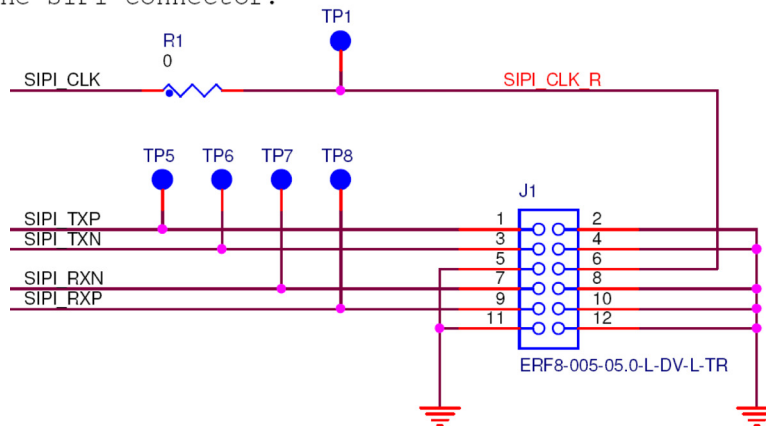

Figure 5. SIPI Interface

Table 5. SIPI connector (J1)

Pin	Signal	Pin	Signal
1	SIPI TXP	2	GND
3	SIPI TXN	4	GND
5	GND	6	SIPI_CLK
7	SIPI RXN	8	GND
9	SIPI RXP	10	GND

4.7 JTAG Interface

A standard JTAG interface is provided on the EVB for debug connections. Note that the Aurora high speed debug interface is only available with the MPC5746R BD trace adapter board provided as part of the Freescale calibration solution. The JTAG interface connections are shown in [Figure 6](#) and listed in [Table 6](#).

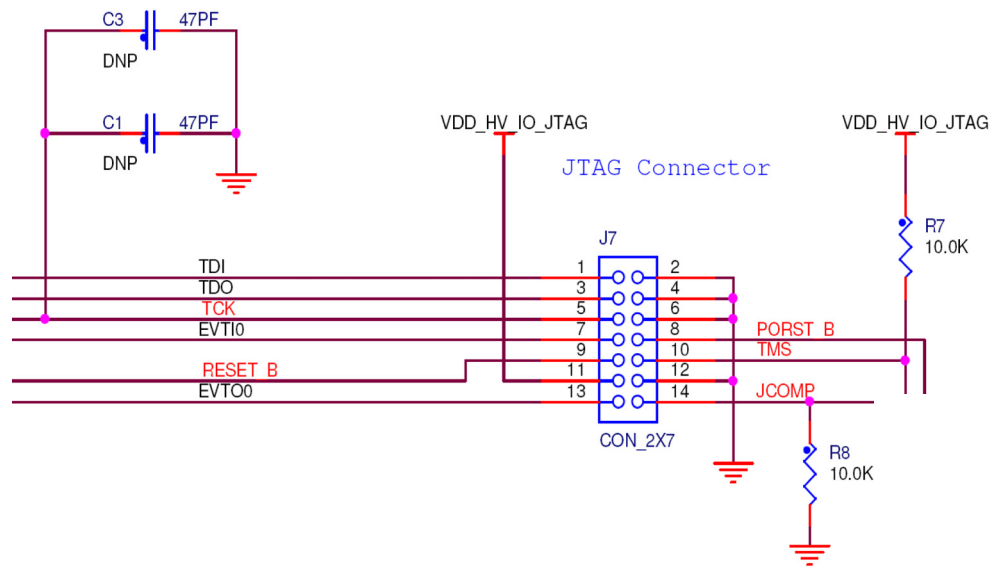

Figure 6. JTAG Interface

Table 6. JTAG connector (J7)

Pin	Signal	Pin	Signal
1	TDI	2	GND
3	TDO	4	GND
5	TCK	6	GND
7	EVTI0	8	PORST_B
9	RESET_B	10	TMS
11	VDD_HV_IO_JTAG	12	GND
13	EVT00	14	JCOMP

4.8 I/O Connectivity and Port Routing

Most of the MCU’s I/Os are routed to the main motherboard. These include the pins associated with the FlexCAN, Ethernet, and LinFlex interfaces and other normal GPIO pins. The MPC57XXXMB provides physical layer drivers for these communication protocols. See the MPC57XXXMB User Guide for the correct jumper settings to enable and configure these drivers and associated circuits.

Table 7 lists the mapping from the MPC5746R device ports to the existing headers/ports on the MPC57XXXMB motherboard, and to the FlexCAN, Ethernet, UART and LinFlex drivers.

Table 7. Port to Motherboard Mapping — 144LQFP, 176LQFP and 252MAPBGA

MPC5746R			Pin Number			MPC57XXXMB Motherboard	
Port	Function		144LQFP	176LQFP	252MAPBGA	144LQFP	176LQFP 252MAPBGA
	144LQFP	176LQFP 252MAPBGA					
PA[0]	MSC0_CS0	—	142	174	A3	PP[7] ²	PA[0]
PA[1]	MSC0_CS1/SIPI_RXN	SIPI_RXN	141	173	B3	PP[8] ²	no connect ¹
PA[2]	MSC0_RX/SIPI_RXP	SIPI_RXP	140	172	A4	PP[9] ²	no connect ¹
PA[3]	MSC0_CLKN	—	139	171	B4	PP[10] ²	PA[3]
PA[4]	MSC0_CLKP/SIPI_CLK	SIPI_CLK	138	170	C4	PP[11] ²	no connect ¹
PA[5]	MSC0_SOUTN/SIPI_TXN	SIPI_TXN	137	169	C5	PP[12] ²	no connect ¹
PA[6]	MSC0_SOUTP/SIPI_TXP	SIPI_TXP	136	168	B5	PP[13] ²	no connect ¹
PA[7]	n/a	MSC1_SOUTN		165	C6	n/a	PP[7] ²
PA[8]	n/a	MSC1_SOUTP		164	C7	n/a	PP[8] ²
PA[9]	n/a	MSC1_CLKN		161	A6	n/a	PP[9] ²
PA[10]	n/a	MSC1_CLKP		160	A7	n/a	PP[10] ²
PA[11]	n/a	MSC1_RX		159	B7	n/a	PP[11] ²
PA[12]	n/a	MSC1_CS1		158	B8	n/a	PP[12] ²
PA[13]	n/a	MSC1_CS0		157	A8	n/a	PP[13] ²
PB[0]	TDO		143	175	D1	no connect ³	
PB[1]	TDI		144	176	E3	no connect ³	
PC[0]	FEC_REF_CLK		45	56	Y9	PA[15]	
PC[1]	FEC_TXCLK		46	57	W9	PK[14]	
PC[2]	FEC_TXEN		47	58	V9	PC[14]	
PC[3]	FEC_TXD3		48	59	U9	PM[5]	
PC[4]	FEC_TXD2		49	60	W10	PM[4]	
PC[5]	FEC_TXD1		50	61	V10	PE[12]	
PC[6]	FEC_TXD0		51	62	U10	PC[15]	
PC[7]	FEC_RXD0		54	65	Y11	PC[12]	
PC[8]	FEC_RXD1		55	66	V11	PC[13]	
PC[9]	FEC_RXD2		56	67	U11	PM[1]	
PC[10]	FEC_RXD3		57	68	Y12	PK[15]	
PC[11]	FEC_RXER		58	69	W12	PM[3]	
PC[12]	FEC_RXCLK		59	70	V12	PC[10]	
PC[13]	FEC_RXDV		60	71	U12	PM[0]	
PD[0]	—		37	45	Y3	PL[0]	
PD[1]	—		38	46	W3	PL[1]	
PD[2]	—				Y4	PL[2]	
PD[3]	—				W4	PL[3]	
PD[4]	—			47	V4	PL[4]	

Table 7. Port to Motherboard Mapping — 144LQFP, 176LQFP and 252MAPBGA

MPC5746R			Pin Number			MPC57XXXMB Motherboard	
Port	Function		144LQFP	176LQFP	252MAPBGA	144LQFP	176LQFP 252MAPBGA
	144LQFP	176LQFP 252MAPBGA					
PD[5]	—				Y5		PL[5]
PD[6]	—				W5		PL[6]
PD[7]	—		39	48	V5		PL[7]
PD[8]	FEC_MDC		40	49	V6		PC[3]
PD[9]	—				Y7		PL[9]
PD[10]	—			52	W7		PL[10]
PD[11]	—			53	V7		PL[11]
PD[12]	—				U7		PL[12]
PD[13]	FEC_MDIO		43	54	Y8		PC[2]
PD[14]	—		44	55	W8		PL[14]
PD[15]	—				V8		PL[15]
PE[0]	—				U8		PE[0]
PF[0]	LIN2TX			126	G20		PD[14]
PF[1]	LIN2RX			127	G19		PD[15]
PF[2]	LIN3TX				G18		PF[2]
PF[3]	LIN3RX				G17		PF[3]
PF[4]	CAN0TX				F19		PF[4]
PF[5]	CAN0RX				D19		PF[5]
PF[6]	CAN1TX				E20		PF[6]
PF[7]	CAN1RX				E18		PF[7]
PF[8]	—				D20		PF[8]
PF[9]	—				D19		PF[9]
PF[10]	CAN1TX				D18		PF[10]
PF[11]	CAN0RX/CAN1RX		106	130	C20		PF[11]
PF[12]	CAN0TX		107	131	C19		PC[9]
PF[13]	CAN0RX		108	132	B20		PC[8]
PG[1]	CAN2RX		109	133	A18		PG[14]
PG[2]	CAN2TX		110	134	A17		PE[5]
PG[3]	—				B17		PG[3]
PG[4]	—				C18		PG[4]
PG[5]	LIN1RX		111	135	B16		PE[6]
PG[6]	LIN1TX		112	136	A16		PE[7]
PG[7]	—				C17		PG[7]
PG[9]	CAN3RX		113	137	C16		PA[11]
PG[10]	—			138	A15		PG[10]
PG[11]	CAN3TX		115	140	B15		PA[10]
PG[12]	—		116	141	B14		PG[12]
PG[13]	—		117	142	A14		PG[13]

Table 7. Port to Motherboard Mapping — 144LQFP, 176LQFP and 252MAPBGA

MPC5746R			Pin Number			MPC57XXXMB Motherboard	
Port	Function		144LQFP	176LQFP	252MAPBGA	144LQFP	176LQFP 252MAPBGA
	144LQFP	176LQFP 252MAPBGA					
PG[14]	—				C15	PE[14]	
PG[15]	—				C14	PE[15]	
PH[0]	—		118	143	D14	PH[0]	
PH[1]	—				A13	PH[1]	
PH[2]	—				B13	PH[2]	
PH[3]	—		119	144	C13	PH[3]	
PH[4]	—				D14	PH[4]	
PH[5]	—				A12	PH[5]	
PH[6]	—				C12	PH[6]	
PH[7]	—		120	145	D12	PH[7]	
PH[8]	—		121	146	B11	PH[8]	
PH[9]	—				C11	PH[9]	
PH[10]	—				D11	PH[10]	
PH[11]	—		125	150	A10	PH[11]	
PH[12]	—		126	151	B10	PH[12]	
PH[13]	—				C10	PH[13]	
PH[14]	—		127	152	D10	PH[14]	
PH[15]	—		128	153	A9	PH[15]	
PI[0]	—		129	154	B9	PI[0]	
PI[1]	—		130	155	C9	PI[1]	
PI[2]	—				D9	PI[2]	
PI[3]	—		131	156	C8	PI[3]	
PI[4]	—				D8	PI[4]	
PI[5]	—				D7	PI[5]	
PJ[0]	—		10	10	H1	PJ[0]	
PJ[1]	—		11	11	G4	PJ[1]	
PJ[2]	—				H2	PJ[2]	
PJ[3]	—			12	H3	PJ[3]	
PJ[4]	EVTI_0		12	13	H4	no connect ³	
PJ[5]	—		17	18	J2	PJ[5]	
PJ[6]	—				J3	PJ[6]	
PJ[7]	EVTO_0		18	19	J4	no connect ³	
PJ[8]	—				K2	PJ[8]	
PJ[9]	—				K3	PJ[9]	
PJ[10]	—				K4	PJ[10]	
PJ[11]	—		24	25	L3	PJ[11]	
PJ[12]	—			26	L4	PJ[12]	
PJ[13]	—			27	M3	PJ[13]	

Table 7. Port to Motherboard Mapping — 144LQFP, 176LQFP and 252MAPBGA

MPC5746R			Pin Number			MPC57XXXMB Motherboard	
Port	Function		144LQFP	176LQFP	252MAPBGA	144LQFP	176LQFP 252MAPBGA
	144LQFP	176LQFP 252MAPBGA					
PJ[14]	—		25	28	M4		PJ[14]
PJ[15]	—			29	N2		PJ[15]
PK[0]	—			30	N3		PS[0]
PK[1]	—		26	31	N4		PS[1]
PK[2]	—		27	32	P1		PS[2]
PK[4]	—			33	P2		PS[4]
PK[5]	—		28	34	P3		PS[5]
PK[7]	—		31	37	P4		PS[7]
PK[8]	—		32	38	R1		PS[8]
PK[9]	—			39	R3		PS[9]
PK[10]	—		33	40	T2		PS[10]
PK[11]	—		34	41	T3		PS[11]
PK[12]	—			42	U1		PS[12]
PK[13]	—		35	43	U2		PS[13]
PK[14]	—		36	44	V1		PS[14]
PW[0]	—				Y13		PW[0]
PW[1]	—		64	76	W13		PW[1]
PW[2]	—			75	V13		PW[2]
PW[3]	—		63	74	U13		PW[3]
PX[0]	—				U19		PX[0]
PX[1]	—		73	89	U18		PX[1]
PX[2]	—		72	88	V18		PX[2]
PX[3]	—		71	87	Y17		PX[3]
PX[4]	—				W17		PX[4]
PX[5]	—		68	84	V17		PX[5]
PX[6]	—				Y16		PX[6]
PX[7]	—		67	83	W16		PX[7]
PX[8]	—				U14		PX[8]
PX[9]	—			82	Y15		PX[9]
PX[10]	—		66	81	W15		PX[10]
PX[11]	—				V15		PX[11]
PX[12]	—			80	Y14		PX[12]
PX[13]	—			79	W14		PX[13]
PX[14]	—		65	78	V14		PX[14]
PX[15]	—			77	V16		PX[15]
PY[0]	SD2_0			101	N20	n/a	no connect ⁴
PY[1]	SD2_1		80	100	N19	no connect ⁶	no connect ⁵

Table 7. Port to Motherboard Mapping — 144LQFP, 176LQFP and 252MAPBGA

MPC5746R			Pin Number			MPC57XXXMB Motherboard	
Port	Function		144LQFP	176LQFP	252MAPBGA	144LQFP	176LQFP 252MAPBGA
	144LQFP	176LQFP 252MAPBGA					
PY[2]	—			99	N18		PT[2]
PY[3]	—				N17		PT[3]
PY[4]	—			98	P20		PT[4]
PY[5]	—				P19		PT[5]
PY[6]	—		79	97	P18		PT[6]
PY[7]	—			96	P17		PT[7]
PY[8]	—				R20		PT[8]
PY[9]	—		78	95	R19		PT[9]
PY[10]	—			94	R18		PT[10]
PY[11]	—				T20		PT[11]
PY[12]	—				T19		PT[12]
PY[13]	—		77	93	T18		PT[13]
PY[14]	—				U20		PT[14]
PY[15]	—		74	90	V20		PT[15]
PZ[0]	—		102	123	H20		PN[0]
PZ[1]	—		101	122	H19		PN[1]
PZ[2]	—		100	121	H18		PN[2]
PZ[3]	—		99	120	H17		PN[3]
PZ[4]	—		98	119	J20		PN[4]
PZ[5]	—		97	118	J19		PN[5]
PZ[6]	—		96	117	J18		PN[6]
PZ[7]	—		95	116	J17		PN[7]
PZ[8]	—		90	111	K18		PB[0]
PZ[9]	—		89	110	K17		PB[1]
PZ[10]	—		88	109	L18		PB[2]
PZ[11]	—		87	108	L17		PB[3]
PZ[12]	—		86	107	M18		PB[4]
PZ[13]	—		85	106	M17		PB[5]
PZ[14]	—		84	105	M20	no connect ⁵	no connect ⁶
PZ[15]	—		83	104	M19	no connect ⁴	no connect ⁶

¹ Routed to Samtech connector 1 on daughter card.

² Routed to Samtech connector 2 on daughter card and to this port number on MB via a zero ohm resistor..

³ Routed to JTAG connector on daughter card

⁴ Routed to N side of differential PI-filter on daughter card

⁵ Routed to P side of differential PI-filter on daughter card

⁶ Routed to Pi-filter on daughter card

5 Reset switches

The push-button switch SW1 provides a power-on-reset signal to the MCU.

6 LEDs

LEDs shown in [Table 8](#) provide indicators for:

- Power from external 5.0 V supply
- Reset states

Table 8. LEDs

LED	Description
D1	5V External Supply
D2	RESET_B
D3	PORST_B

7 Test points

Test points shown in [Table 9](#) are available to allow probing of various voltages and signals.

Table 9. Test points

Test Point	Description
TP1	SIPI_CLK
TP2	VDD_HV_MSC
TP3	VDD_STBY
TP4	VDD_HV_IO_JTAG
TP5	SIPI_TXP
TP6	SIPI_TXN
TP7	SIPI_RXN
TP8	SIPI_RXP
TP9	GND
TP10	GND
TP11	VSSA_JTAG
TP12	VDD_HV_ADV_SD
TP13	VSSA_ADC
TP14	VDD_HV_PMC
TP15	VDD_HV_FLA
TP16	VDD_LV_CORE
TP17	GND
TP18	GND
TP19	VDD_HV_IO_FEC
TP20	VDD_HV_ADV_SAR

Table 9. Test points (continued)

Test Point	Description
TP21	VDD_HV_IO_MAIN

8 Schematics

The MPC5746R-176DS, MPC5746R-252DS and MPC5746R-144DS schematics are available as an attachment in this PDF document. To access the schematic open the bookmark window and click on the paper clip icon on the left side of the page.

9 EVB Errata

EVB errata are listed in the following table.

Errata List

Errata	Description	Affected			Workaround
		176DS	252DS	144DS	
1	Port pin PG[9] (CAN3RX) on the MPC5746R was routed to motherboard port pin PA[13] instead of PA[11]. PA[11] is also routed on the motherboard to J38, which is a selectable RX pin for the CAN transceiver. This prevents the CAN RX signal from being connected directly via motherboard trace to the PG[9] pin on the MPC5746R for the CAN3RX function.	Yes	No	No	To connect the RX signal from the CAN bus interface (J6) to the CAN3RX signal on the MPC5746R device at pin PG[9], place a wire jumper from PA[13] on the motherboard to pin 3 on J38.

10 Revision history

Table 10. Revision history

Revision number	Date	Description
1.0	04/24/2013	Initial version.
1.1	04/25/2013	Updated from review comments.
1.2	04/25/2013	Added EVB Errata section and updated with current known errata.
1.3	09/09/2013	Updated Table 7 to include port mappings from 252MAPBGA pins. Other minimal modifications to various sections so that User Guide supports both 176 and 252 packages.
1.4	09/11/2013	Removed Top View section. Updated Errata list to included affected DS
1.5	04/23/2014	Updated Table 7 to include port mappings from 144LQFP pins. Other minimal modifications to various sections so that User Guide supports the 176, 252, and 144 packages.
1.6	09/01/2015	Changed all instances of MPC5746M to MPC57XXX.

How to Reach Us:

Home Page:
freescale.com

Web Support:
freescale.com/support

Information in this document is provided solely to enable system and software implementers to use Freescale products. There are no express or implied copyright licenses granted hereunder to design or fabricate any integrated circuits based on the information in this document.

Freescale reserves the right to make changes without further notice to any products herein. Freescale makes no warranty, representation, or guarantee regarding the suitability of its products for any particular purpose, nor does Freescale assume any liability arising out of the application or use of any product or circuit, and specifically disclaims any and all liability, including without limitation consequential or incidental damages. "Typical" parameters that may be provided in Freescale data sheets and/or specifications can and do vary in different applications, and actual performance may vary over time. All operating parameters, including "typicals," must be validated for each customer application by customer's technical experts. Freescale does not convey any license under its patent rights nor the rights of others. Freescale sells products pursuant to standard terms and conditions of sale, which can be found at the following address: <http://www.reg.net/v2/webservices/Freescale/Docs/TermsandConditions.htm>

Freescale, the Freescale logo, Altivec, C-5, CodeTest, CodeWarrior, ColdFire, C-Ware, Energy Efficient Solutions logo, Kinetis, mobileGT, PowerQUICC, Processor Expert, QorIQ, Qorivva, StarCore, Symphony, and VortiQa are trademarks of Freescale Semiconductor, Inc., Reg. U.S. Pat. & Tm. Off. Airfast, BeeKit, BeeStack, ColdFire+, CoreNet, Flexis, MagniV, MXC, Platform in a Package, QorIQ Qonverge, QUICC Engine, Ready Play, SafeAssure, SMARTMOS, TurboLink, Vybrid, and Xtrinsic are trademarks of Freescale Semiconductor, Inc. All other product or service names are the property of their respective owners. The Power Architecture and Power.org word marks and the Power and Power.org logos and related marks are trademarks and service marks licensed by Power.org.

© 2012 Freescale Semiconductor, Inc.

Document Number: MPC5746REVB176UG
Rev. 1.6
9/2015





Стандарт Электрон Связь

Мы молодая и активно развивающаяся компания в области поставок электронных компонентов. Мы поставляем электронные компоненты отечественного и импортного производства напрямую от производителей и с крупнейших складов мира.

Благодаря сотрудничеству с мировыми поставщиками мы осуществляем комплексные и плановые поставки широчайшего спектра электронных компонентов.

Собственная эффективная логистика и склад в обеспечивает надежную поставку продукции в точно указанные сроки по всей России.

Мы осуществляем техническую поддержку нашим клиентам и предпродажную проверку качества продукции. На все поставляемые продукты мы предоставляем гарантию .

Осуществляем поставки продукции под контролем ВП МО РФ на предприятия военно-промышленного комплекса России , а также работаем в рамках 275 ФЗ с открытием отдельных счетов в уполномоченном банке. Система менеджмента качества компании соответствует требованиям ГОСТ ISO 9001.

Минимальные сроки поставки, гибкие цены, неограниченный ассортимент и индивидуальный подход к клиентам являются основой для выстраивания долгосрочного и эффективного сотрудничества с предприятиями радиоэлектронной промышленности, предприятиями ВПК и научно-исследовательскими институтами России.

С нами вы становитесь еще успешнее!

Наши контакты:

Телефон: +7 812 627 14 35

Электронная почта: sales@st-electron.ru

Адрес: 198099, Санкт-Петербург,
Промышленная ул, дом № 19, литера Н,
помещение 100-Н Офис 331