

## Introduction

The EVK-UFT285-6-7 is designed to help the customer evaluate the 8T49N285, 8T49N286, and 8T49N287 devices, members of IDT's 3rd generation Universal Frequency Translator family. When the board is connected to a PC running IDT Timing Commander™ software through USB, the device can be configured and programmed to generate frequencies with best-in-class performances.

## Contents

The EVK-UFT285-6-7 evaluation board ships with the following:

- 1 – EVK-UFT285-6-7 Evaluation Board
- 1 – USB Cable

## Requirements

### 1. PC Requirements:

- IDT Timing Commander software installed.
- USB 2.0 interface. The evaluation board USB module is not compatible with USB 3.0. If using a computer with high speed USB ports, please check if there's a standard USB 2.0 port available for use. The hardware drivers are automatically installed during the Timing Commander installation.
- Windows XP SP3 or later.
- Processor: Minimum 1GHz.
- Memory: Minimum 512MB, recommended 1GB.
- Available Disk Space: Min 600MB (1.5GB 64bit), recommended 1GB (2GB 64bit)
- Network access during installation if the .NET framework is not currently installed on the system.

### 2. Power Supply with 3.3V and 1000mA rating

### 3. Three banana plug cables to connect the power supply to the board.

## Quick Start: Powering Up the Board

- (1) Set 3.3V supply current limit to 500mA.
- (2) Remove all output terminations.
- (3) Set Dip Switch selectors to the middle position.
- (4) Connect a cable from a PC to the USB port.
- (5) Connect VEE to the black GND jack.
- (6) Connect 3.3V to VCC\_J and VDDO\_J.
- (7) Power on the Power Supply.
- (8) Press the Reset Button.

Once correct operation is verified, set the power supply limit for the number of outputs to be active.



The USB port must be powered by the PC in order to have the correct I<sup>2</sup>C bus voltage levels.

The board ships with a 38.88MHz crystal and will have a default frequency of 155.52MHz on Q0. If all outputs are unterminated, current should measure ~256mA with 3.3V on VCC\_J and VDDO\_J. If all outputs are terminated, current should measure ~262mA.

When evaluating performance with the default hardware configuration, it is recommended that all active outputs be terminated 50ohms to VEE by either terminator plugs or an instrument.

## Board Overview

Use the following diagram to identify: power supply jacks, USB connector, input and output SMA connectors, reset button, EEPROM, etc.

Figure 1. Evaluation Board Top View

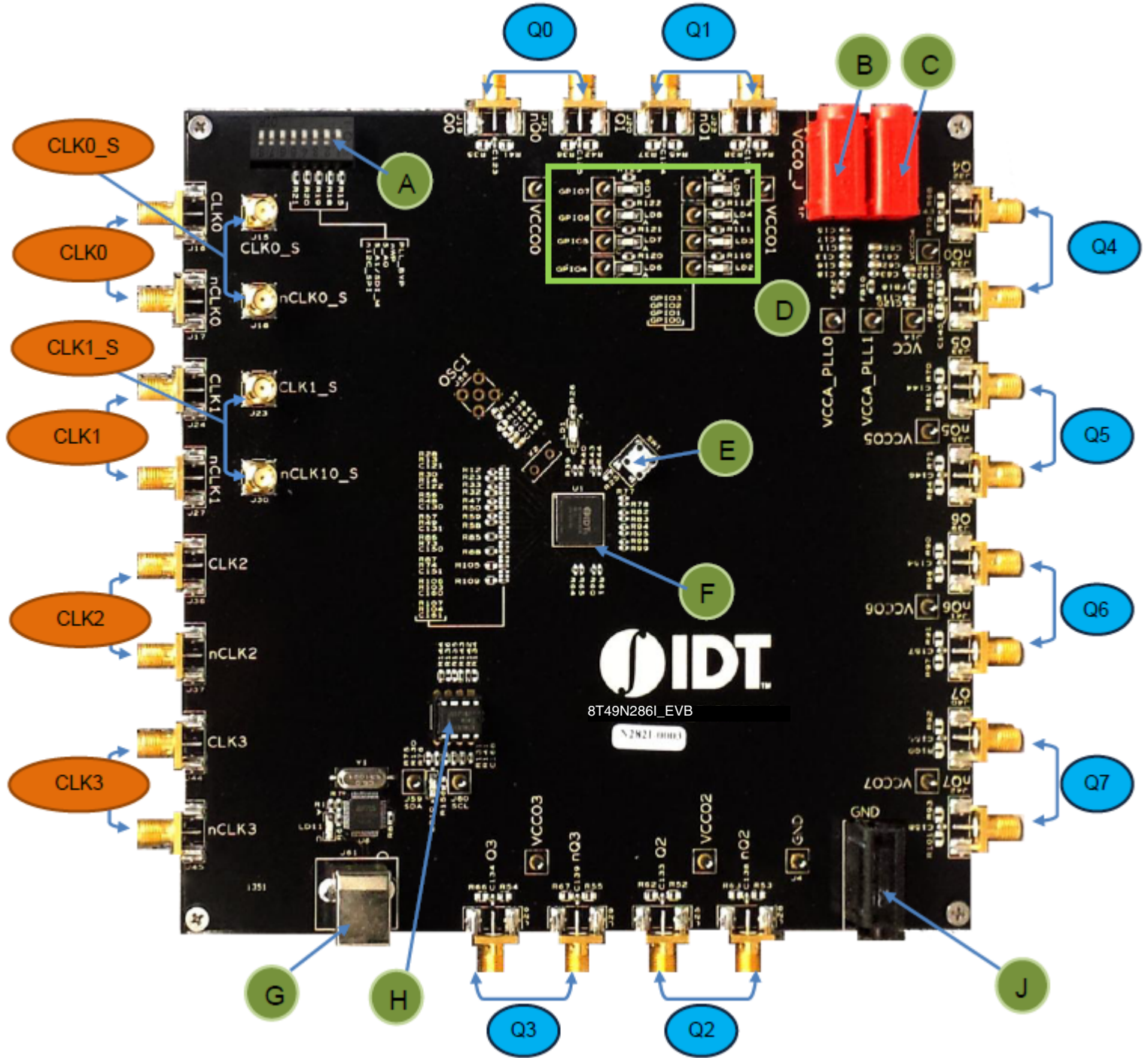

## Legend–Evaluation Board Top View

### Inputs

CLK0_S	Clock 0 sense lines.
CLK0	Clock 0 input lines. Can be configured for differential or single-ended input.
CLK1_S	Clock 1 sense lines.
CLK1	Clock 1 input lines. Can be configured for differential or single-ended input.
CLK2	Clock 2 input lines. Can be configured for differential or single-ended input.
CLK3	Clock 3 input lines. Can be configured for differential or single-ended input.

### Outputs

Q0	Output Q0. Can be a differential pair or two individual single-ended outputs.
Q1	Output Q1. Can be a differential pair or two individual single-ended outputs.
Q2	Output Q2. Can be a differential pair or two individual single-ended outputs.
Q3	Output Q3. Can be a differential pair or two individual single-ended outputs.
Q4	Output Q4. Can be a differential pair or two individual single-ended outputs.
Q5	Output Q5. Can be a differential pair or two individual single-ended outputs.
Q6	Output Q6. Can be a differential pair or two individual single-ended outputs.
Q7	Output Q7. Can be a differential pair or two individual single-ended outputs.

### Other

A	Dip Switch for DC control signals (CLK_SEL, PLL_BYPASS, etc)
B	VCCO_J
C	VCC_J
D	GPIOs
E	RESET
F	IDT8T49N286 – the device to be evaluated
G	USB connector
H	EEPROM – AT24CO4C
J	Ground Jack

Figure 2. Evaluation Board Bottom View

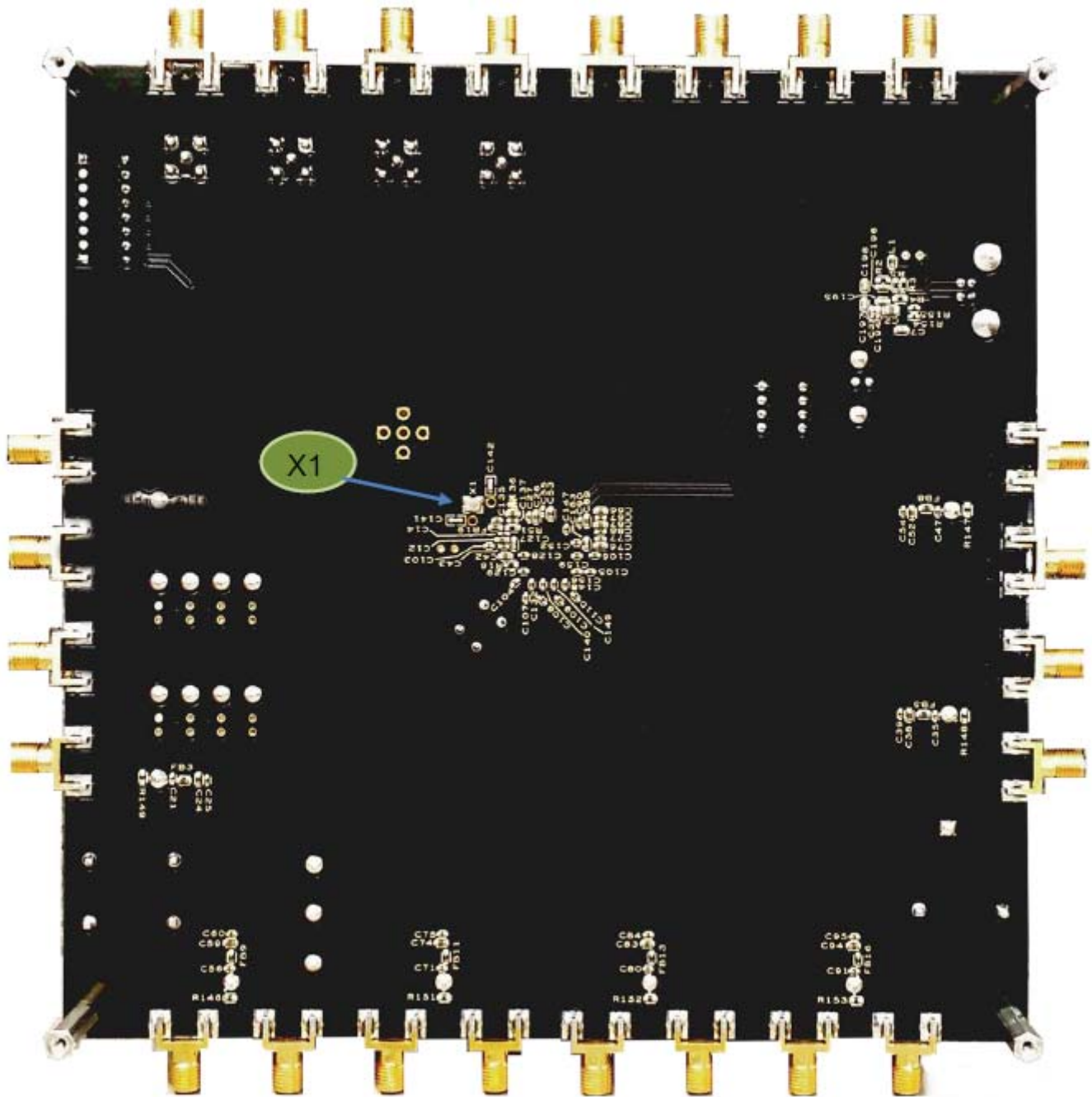

Legend–Evaluation Board Bottom View

X1 3.2 x 2.5 mm SMD Fox-603-38.88-4 Crystal

## Schematics

The following figures are schematics that are applicable to specific sections of this User Guide. The complete schematics are available in a separate document.

**Figure 3. Inputs Schematic**

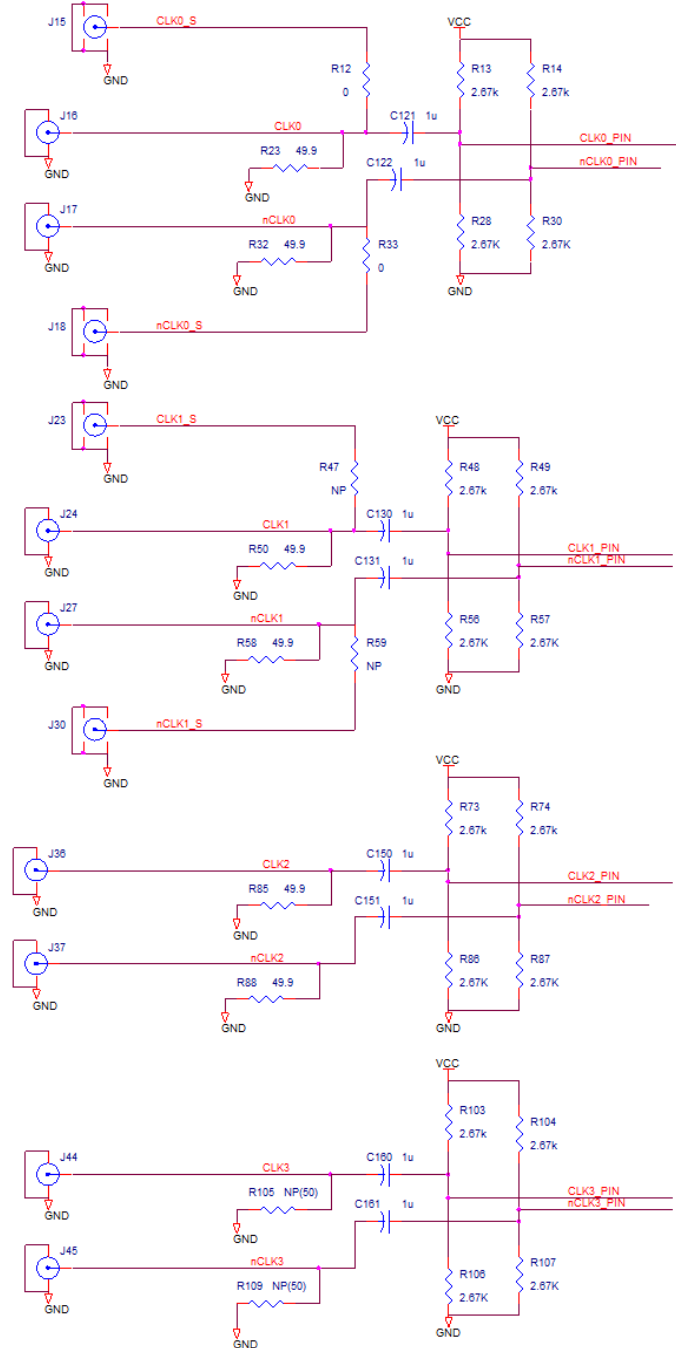



Figure 4. Output Termination Schematic

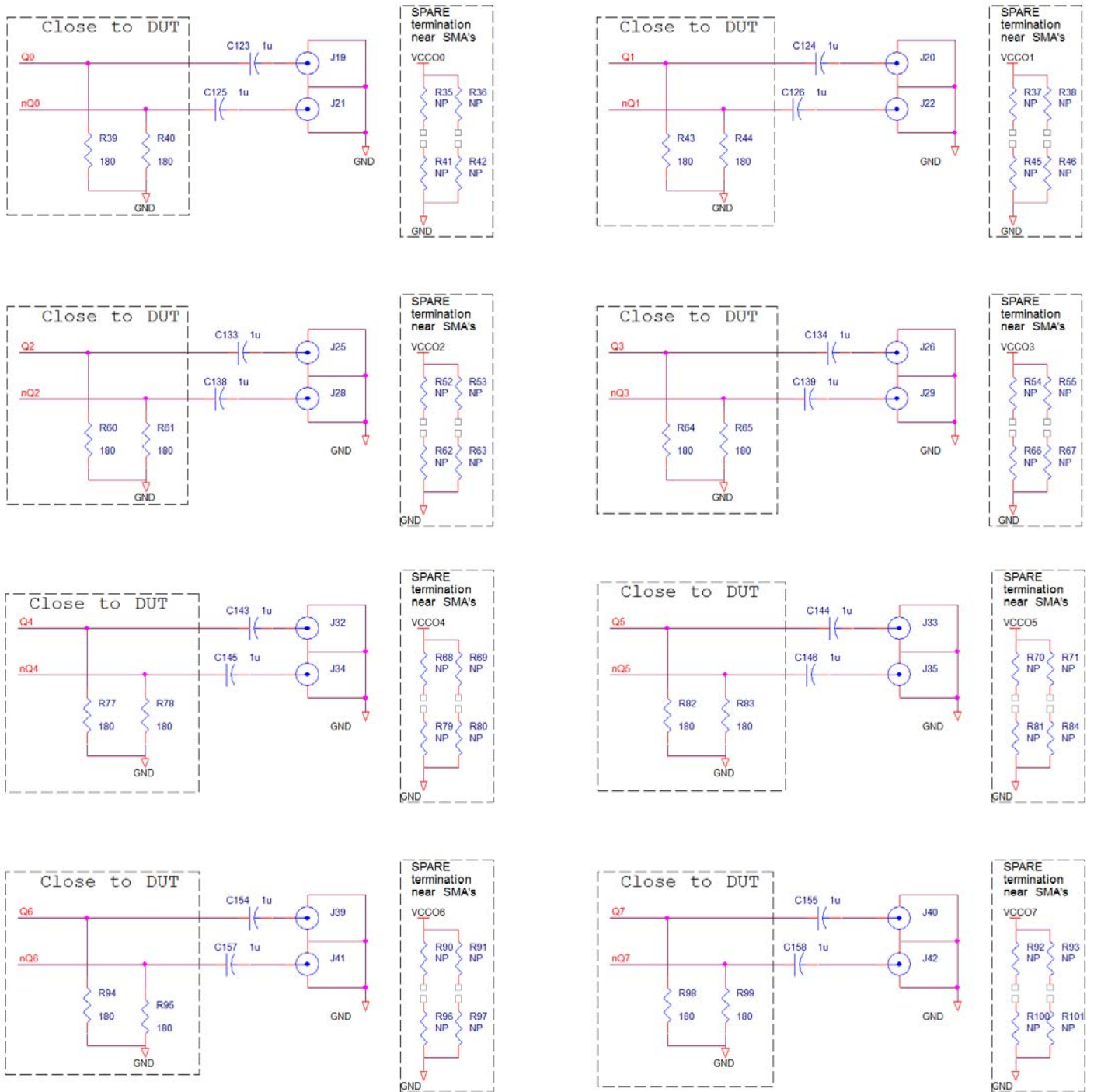
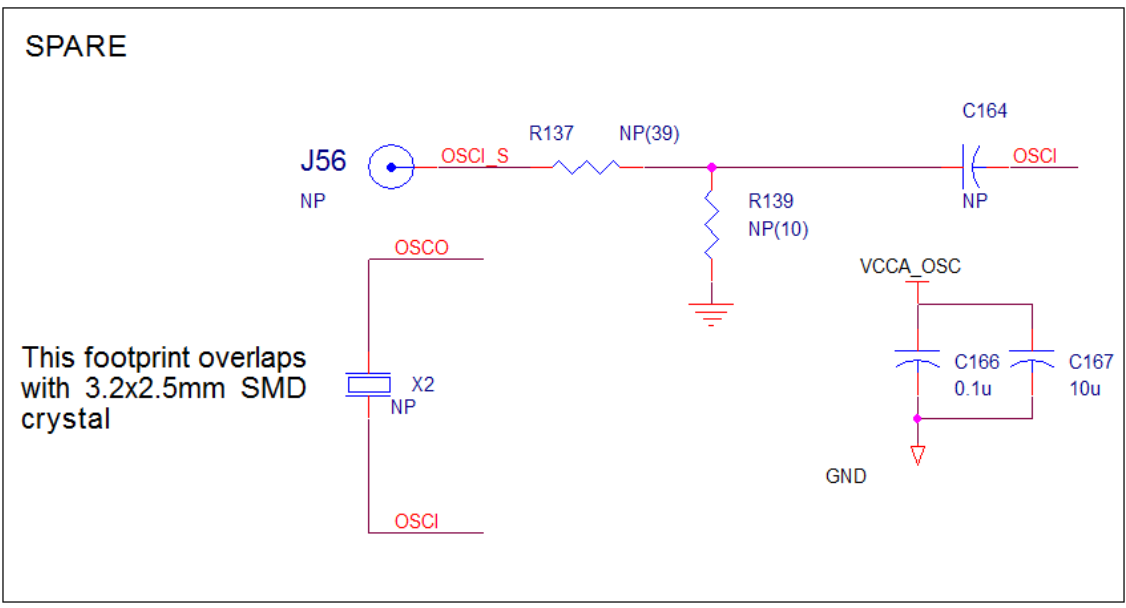
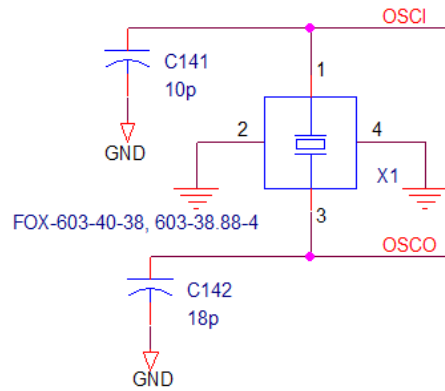
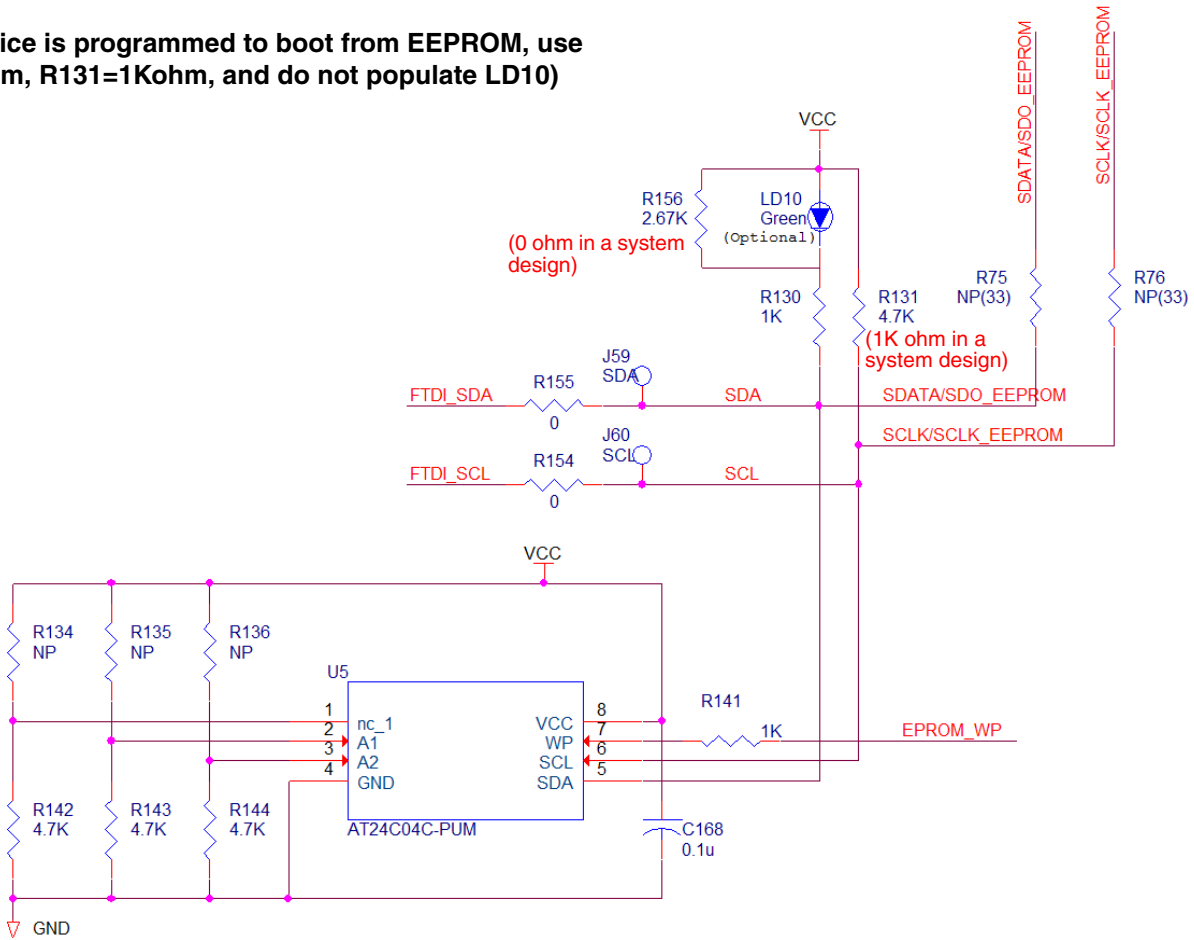

Figure 5. Crystal Interface Schematic



**Figure 6. EEPROM/I<sup>2</sup>C Schematic**

(If the device is programmed to boot from EEPROM, use R156=0ohm, R131=1Kohm, and do not populate LD10)



**Figure 7. DC Control Schematic**

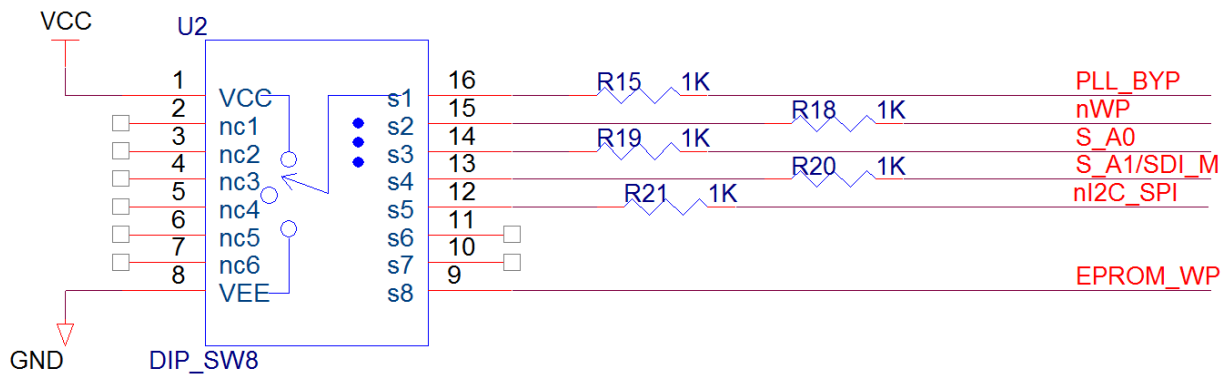



Figure 8. VCCO Power Filtering

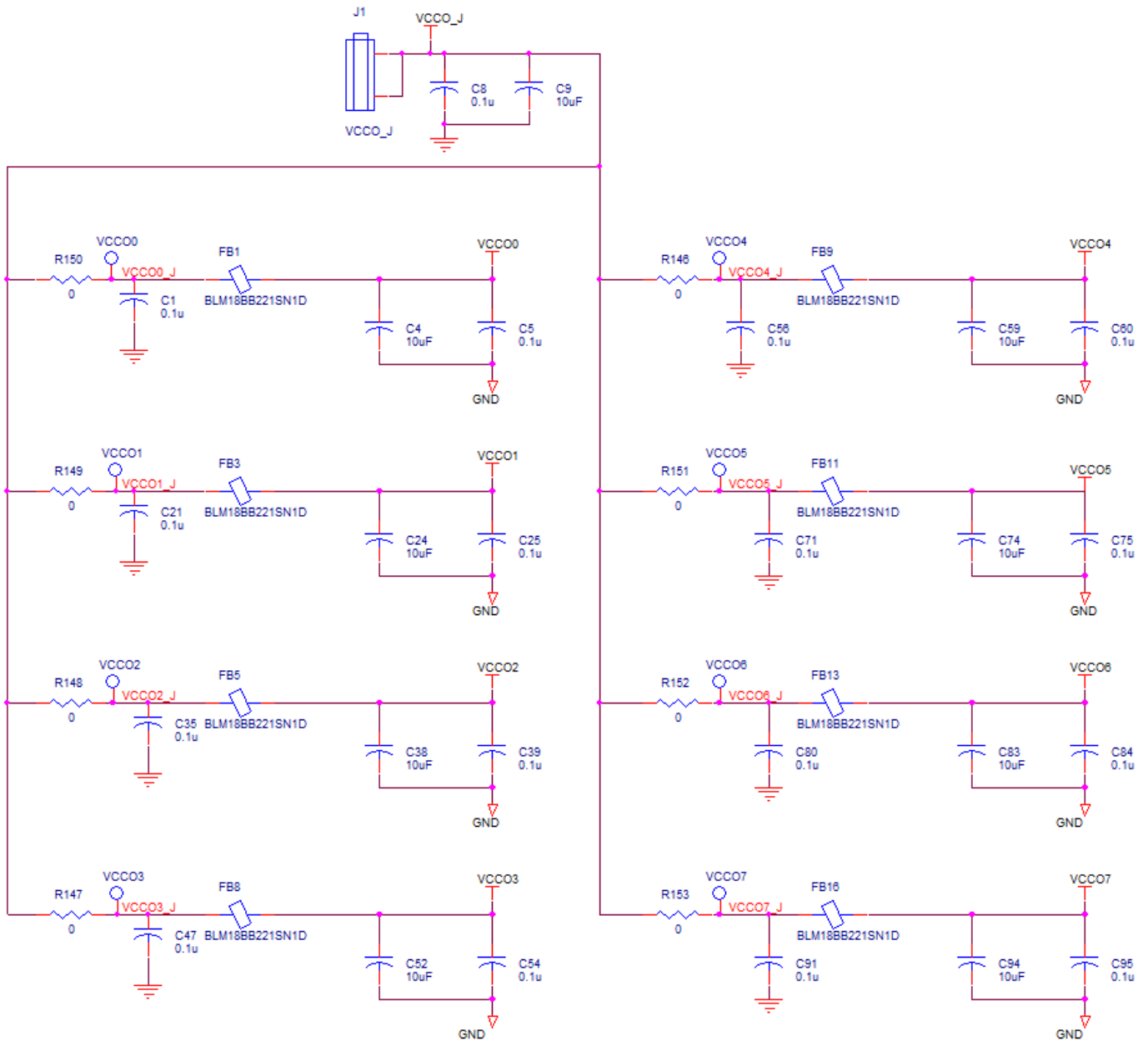
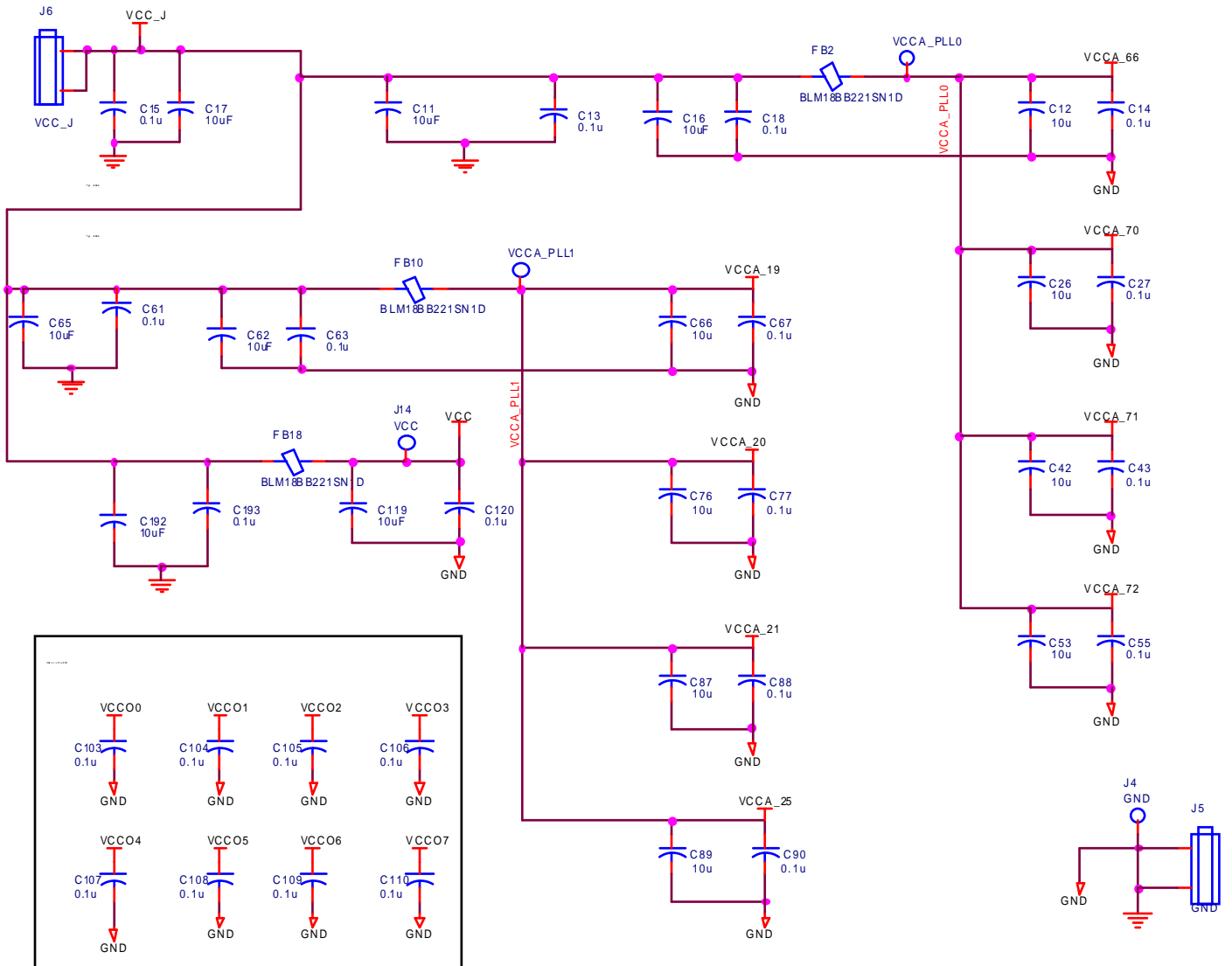

Figure 9. VCC Filtering



## Board Power Supply

### Core Voltages

The core voltage includes a digital voltage VDD and an analog voltage VDDA. Both core voltages are powered by the external bench power supply connected to J6 (VCC\_J). See [Figure 9](#) for details

### Output Voltages

VDDO\_J (J1) supplies the global voltage for the outputs and can be biased by the external power supply at 1.8V (all outputs LVCMOS), 2.5V, or 3.3V.

### Mixed Voltage Operation

This board provides the option to operate the outputs with a mixed combination of output voltages. Refer to [Figure 8](#) for a complete view of the VCCO schematic. Each VCCO<sub>x</sub> has a 0Ω resistor that connects it to the global VCCO\_J power rail. This resistor can be removed and the voltage can be provided using the test point. For example, the schematic below can be configured so that Q0 (VCCO0) operates at 2.5V and Q4 LVCMOS (VCCO4) operates at 1.8V as follows:

- 1) Connect 2.5V to J1 (VCCO\_J).
- 2) Remove R146. This isolates VCCO4 from global VCCO\_J.
- 3) Solder a wire onto test point VCCO4 and bias with a 1.8V supply.

**Figure 10. Mixed Output Voltage Operation**

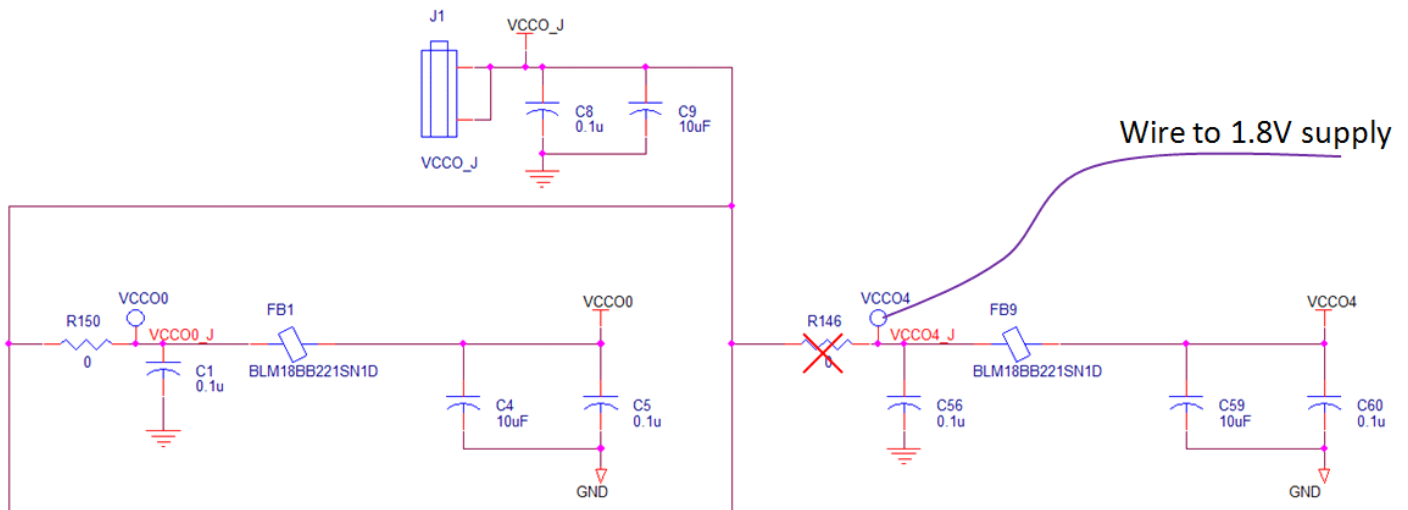

## Input Configuration

The inputs are configured with an ac-coupling termination scheme. This scheme allows flexibility for either differential or single-ended inputs. The default configuration is as follows:

**Table 1: Default Input Configuration**

Input	Default Termination	Sense Lines
CLK0	50ohms to ground, ac-coupled into the device	Use SMAs J15/J18 for observation of the input signal
CLK1	50ohms to ground, ac-coupled into the device	Available but not connected. Populate R47 and R59 to observe input signal on SMAs J23/J30
CLK2	50ohms to ground, ac-coupled into the device	Not available
CLK3	50ohms to ground, ac-coupled into the device	Not available

### Differential Input

Connect the input signal to CLKx and nCLKx. For CLK0, the CLK0\_S and nCLK0\_s sense lines are available for observation of the signal. They can be connected with 50ohm impedance cables to an oscilloscope with 50ohm termination, otherwise, they should be terminated with 50ohm plugs in order prevent reflections.

### Single-ended Input

Connect the input signal to CLKx and float nCLKx. For CLK0, connect CLK0\_S with a 50ohm impedance cable to an oscilloscope with 50ohm termination or terminate with a 50ohm plug.

### Input Signals below 1MHz

For slow-frequency signals below 1MHz, we recommend that the coupling capacitors for the corresponding input be replaced with zero-ohm resistors and that the signal input dc-offset be set so that it meets the device's Vcmr requirements. Refer to [Figure 3](#) to locate the components listed below.

**Table 2: Input Termination Schemes**

Signal Frequency	AC-coupling capacitors: CLK0 (C121, C122) CLK1 (C130,C131) CLK2 (C150,C151) CLK3 (C160,C161)	Input Signal DC Offset
>1MHz	1 $\mu$ F	Don't care
<1MHz	$\Omega$	Must meet datasheet Vcmr specs

## Output Configuration

The outputs are ac-coupled, allowing for maximum flexibility for observation of the output whether configured for LVPECL, LVDS, or LVCMOS levels. The default termination scheme can be used to measure either of the three output level-types but is not optimal. The optimal termination circuits are tabulated below. Refer to [Figure 4](#) to locate the components listed below.

**Table 3: Termination Outputs for Q0**

Signal Type	180 ohm pull-down: R39, R40	Series capacitors: C123, C125	Resistor Network: R35, R36, R41, R42
LVPECL (Default)	Installed	1 $\mu$ F	Not installed
LVCMOS	Not installed	33 ohm	Not installed
LVDS	Not installed	1 $\mu$ F	Not installed

**Table 4: Termination Outputs for Q1**

Signal Type	180 ohm pull-down: R43, R44	Series capacitors: C124, C126	Resistor Network: R37, R38, R45, R46
LVPECL (Default)	Installed	1 $\mu$ F	Not installed
LVCMOS	Not installed	33 ohm	Not installed
LVDS	Not installed	1 $\mu$ F	Not installed

**Table 5: Termination Outputs for Q2**

Signal Type	180 ohm pull-down: R60, R61	Series capacitors: C133, C138	Resistor Network: R52, R53, R62, R63
LVPECL (Default)	Installed	1 $\mu$ F	Not installed
LVCMOS	Not installed	33 ohm	Not installed
LVDS	Not installed	1 $\mu$ F	Not installed

**Table 6: Termination Outputs for Q3**

Signal Type	180 ohm pull-down: R64, R65	Series capacitors: C134, C139	Resistor Network: R54, R55, R66, R67
LVPECL (Default)	Installed	1 $\mu$ F	Not installed
LVCMOS	Not installed	33 ohm	Not installed
LVDS	Not installed	1 $\mu$ F	Not installed

**Table 7: Termination Outputs for Q4**

Signal Type	180 ohm pull-down: R77, R78	Series capacitors: C143, C145	Resistor Network: R68, R69, R79, R80
LVPECL (Default)	Installed	1 $\mu$ F	Not installed
LVCMOS	Not installed	33 ohm	Not installed
LVDS	Not installed	1 $\mu$ F	Not installed

**Table 8: Termination Outputs for Q5**

Signal Type	180 ohm pull-down: R82, R83	Series capacitors: C144, C146	Resistor Network: R70, R71, R81, R84
LVPECL (Default)	Installed	1 $\mu$ F	Not installed
LVC MOS	Not installed	33 ohm	Not installed
LVDS	Not installed	1 $\mu$ F	Not installed

**Table 9: Termination Outputs for Q6**

Signal Type	180 ohm pull-down: R94, R95	Series capacitors: C154, C157	Resistor Network: R90, R91, R96, R97
LVPECL (Default)	Installed	1 $\mu$ F	Not installed
LVC MOS	Not installed	33 ohm	Not installed
LVDS	Not installed	1 $\mu$ F	Not installed

**Table 10: Termination Outputs for Q7**

Signal Type	180 ohm pull-down: R98, R99	Series capacitors: C155, C158	Resistor Network: R92, R93, R100, R101
LVPECL (Default)	Installed	1 $\mu$ F	Not installed
LVC MOS	Not installed	33 ohm	Not installed
LVDS	Not installed	1 $\mu$ F	Not installed

As noted, the 4-resistor network is not installed in Tables 3~10 because an oscilloscope with internal 50 $\Omega$  termination is utilized for signal termination and measurement. If a DC-coupled, stand-alone LVPECL output is needed (without oscilloscope connections), the 4-resistor network needs to be installed accordingly. The table below provides the configuration for Q0:

**Table 11: Resistor Termination Outputs for LVPECL for Q0**

Signal Type	180 ohm pull-down: R39, R40	Series capacitors: C123, C125	Resistor Network: R35, R36, R41 R42
LVPECL (Default)	Not installed	0 ohm	R35=R36=125ohm R41=R42=84ohm

## Output signals below 1MHz

For slow-frequency output signals below 1MHz, we recommend that the 1 $\mu$ F ac-coupling capacitors be replaced with 0ohm resistors and that the correct terminations be provided at the receiver.



## EEPROM Boot

The evaluation board ships with an IDT8T49N286-997 device, which will attempt to boot from the EEPROM at power-up. By default, the EEPROM boot is not enabled on the board. If use of the EEPROM boot is required, there are three options to enable this mode.

- 1) **No Rework Option.** This option will enable the EEPROM boot and does not require any soldering. This sequence must be performed each time the EEPROM needs to be reloaded into the device.
  - a. Hold down the reset button.
  - b. Unplug and then plug in the USB cable.
  - c. Release the reset button.
- 2) **Rework Option.** This option will enable the EEPROM boot but requires soldering. It does not require continually unplugging/plugging-in the USB cable for reloading of the EEPROM into the device.
  - a. Remove LD10 or replace R156 with a 1Kohm resistor. (See [Figure 6](#)).
  - b. Power up the board with USB cable connected.
  - c. Press and release the reset button.
- 3) **Stand-Alone Use.** Sometimes it's necessary to evaluate the device inside a temperature chamber, a system rack, or a Faraday cage where a USB connection to the device is impractical. For such cases contact IDT for further support.

For details on how to program the EEPROM, please refer to document *How to Program the 8T49N28x EEPROM*.

## DC Controls

The Dip Switch has three settings: 0V, Float, and VCC. This board ships with all switches in the Float (middle) position. Refer to [Figure 1](#), label "A" for the location of the Dip Switch.

## Crystal Interface

By default, a 3.2x2.5mm SMD 38.88MHz crystal is installed on bottom side of the board. It provides the reference frequency for the device. This board supports other options for the XTAL\_IN reference. If using one of the other options, the crystal on X1 must be removed.

- 1) **Through-hole crystal.** With this option, the device can be evaluated with different crystals without the need to solder each time the crystal is replaced:
  - a. Remove the crystal from X1 on bottom-side of the board. (See [Figure 2](#), "X1" for location of the component.)
  - b. Solder in crystal sockets into the holes labeled X2. (See [Figure 11](#) below for location of the component.)
  - c. Place a crystal into the socket.

**Figure 11. Crystal Interface PCB**

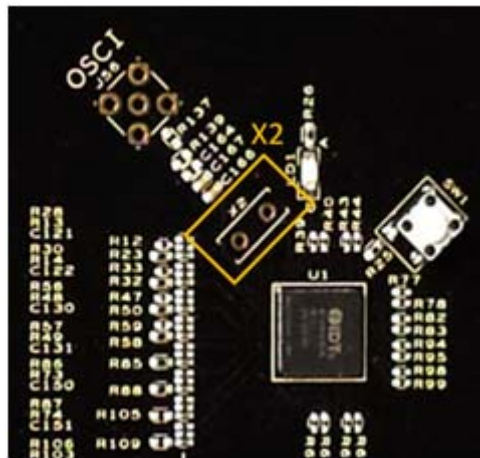

- 2) **Crystal Overdrive.** With this option, the device can be evaluated with different sources, such as frequency generators, XO's, or other devices. Refer to [Figure 5](#) and [Figure 10](#) for identification of the components mentioned below.
  - a. Remove the crystal from X1. (See [Figure 2](#), "X1" for location of the component.)
  - b. Populate SMA J56.
  - c. Solder a 1 $\mu$ F capacitor onto C164. Note: the input **must** be ac-coupled
  - d. R139 may be populated with a 50ohm resistor for input sources requiring such termination.
  - e. R137 must be populated. It may be a 0ohm resistor for input sources or 33ohms for CMOS inputs.



**Corporate Headquarters**  
6024 Silver Creek Valley Road  
San Jose, CA 95138 USA

**Sales**  
1-800-345-7015 or  
408-284-8200  
Fax: 408-284-2775  
www.IDT.com

**Tech Support**  
email: [clocks@idt.com](mailto:clocks@idt.com)  
480-763-2056

DISCLAIMER Integrated Device Technology, Inc. (IDT) and its subsidiaries reserve the right to modify the products and/or specifications described herein at any time and at IDT's sole discretion. All information in this document, including descriptions of product features and performance, is subject to change without notice. Performance specifications and the operating parameters of the described products are determined in the independent state and are not guaranteed to perform the same way when installed in customer products. The information contained herein is provided without representation or warranty of any kind, whether express or implied, including, but not limited to, the suitability of IDT's products for any particular purpose, an implied warranty of merchantability, or non-infringement of the intellectual property rights of others. This document is presented only as a guide and does not convey any license under intellectual property rights of IDT or any third parties.

IDT's products are not intended for use in applications involving extreme environmental conditions or in life support systems or similar devices where the failure or malfunction of an IDT product can be reasonably expected to significantly affect the health or safety of users. Anyone using an IDT product in such a manner does so at their own risk, absent an express, written agreement by IDT.

Integrated Device Technology, IDT and the IDT logo are registered trademarks of IDT. Product specification subject to change without notice. Other trademarks and service marks used herein, including protected names, logos and designs, are the property of IDT or their respective third party owners.

Copyright 2015. All rights reserved.



**Стандарт  
Электрон  
Связь**

Мы молодая и активно развивающаяся компания в области поставок электронных компонентов. Мы поставляем электронные компоненты отечественного и импортного производства напрямую от производителей и с крупнейших складов мира.

Благодаря сотрудничеству с мировыми поставщиками мы осуществляем комплексные и плановые поставки широчайшего спектра электронных компонентов.

Собственная эффективная логистика и склад в обеспечивает надежную поставку продукции в точно указанные сроки по всей России.

Мы осуществляем техническую поддержку нашим клиентам и предпродажную проверку качества продукции. На все поставляемые продукты мы предоставляем гарантию .

Осуществляем поставки продукции под контролем ВП МО РФ на предприятия военно-промышленного комплекса России , а также работаем в рамках 275 ФЗ с открытием отдельных счетов в уполномоченном банке. Система менеджмента качества компании соответствует требованиям ГОСТ ISO 9001.

Минимальные сроки поставки, гибкие цены, неограниченный ассортимент и индивидуальный подход к клиентам являются основой для выстраивания долгосрочного и эффективного сотрудничества с предприятиями радиоэлектронной промышленности, предприятиями ВПК и научно-исследовательскими институтами России.

С нами вы становитесь еще успешнее!

**Наши контакты:**

**Телефон:** +7 812 627 14 35

**Электронная почта:** [sales@st-electron.ru](mailto:sales@st-electron.ru)

**Адрес:** 198099, Санкт-Петербург,  
Промышленная ул, дом № 19, литера Н,  
помещение 100-Н Офис 331