

AMPHENOL PART NUMBER CONFIGURATION  
**UE86-3G4620-X0X61**

- LIGHT PIPE OPTION**
- 0 - NO LIGHT PIPE
  - 1 - 4 LP PER 2X1, NORMAL ORIENTATION
  - 2 - 2 INNER LP PER 2X1, NORMAL ORIENTATION
  - 3 - 2 OUTER LP PER 2X1, NORMAL ORIENTATION
  - 4 - 4 LP PER 2X1, REVERSING ORIENTATION
  - 5 - 2 INNER LP PER 2X1, REVERSING ORIENTATION
  - 6 - 2 OUTER LP PER 2X1, REVERSING ORIENTATION
  - 7 - 3 LP PER 2X1, 2 OUTER LP, NORMAL ORIENTATION
  - 8 - 3 LP PER 2X1, 2 OUTER LP, REVERSING ORIENTATION

- PACKAGING**
- 1 - TRAY PACKAGING (STACKED)
- PLATING OPTIONS FOR CONNECTOR**
- 2 - 30µ" GOLD PLATING ON MATING AREA  
15-100µ" MATTE TIN ON TERMINATION
  - 3 - 30µ" GOLD PLATING ON MATING AREA  
150-300µ" MATTE TIN ON TERMINATION
  - 5 - 15µ" GOLD PLATING ON MATING AREA  
15-100µ" MATTE TIN ON TERMINATION
  - 6 - 15µ" GOLD PLATING ON MATING AREA  
150-300µ" MATTE TIN ON TERMINATION

REVISIONS				
REV.	ECN	DESCRIPTION	DATE	APPROVED
A		PROPOSAL	FEB 07/14	J. SI
B		UPDATE PLATING OPTIONS	JUN 25/14	J.SI
C		UPDATE NOTES	AUG 19/14	J.SI

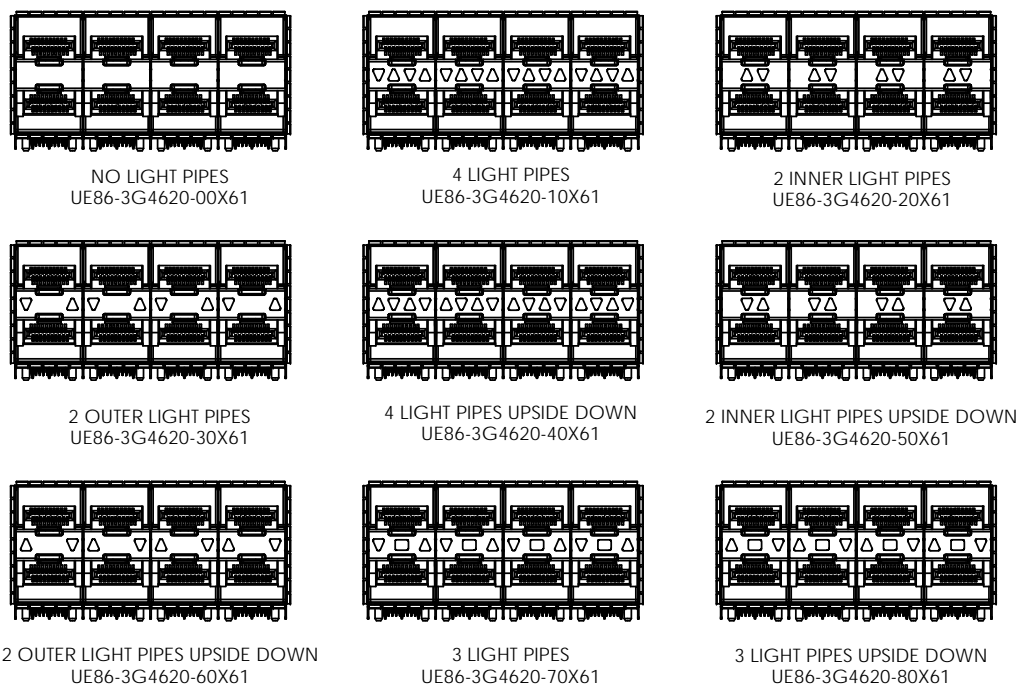
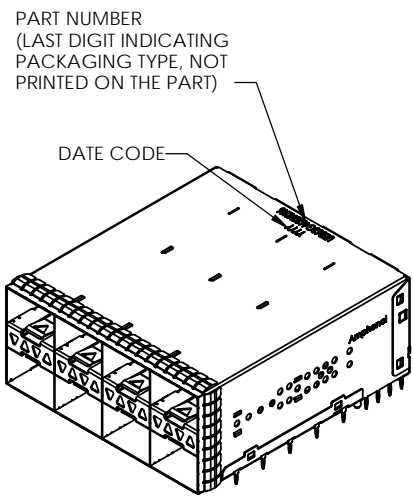

MATERIAL: (RoHS COMPLIANT)

1. CAGE - PRESS FIT: COPPER ALLOY (NICKEL SILVER)
2. CONNECTOR - PRESS FIT:  
- PLASTIC HOUSING: LCP, FLAMMABILITY RATING UL94-V0  
- CONTACTS: PHOSPHOR BRONZE
3. LIGHT PIPE: CLEAR POLYCARBONATE, FLAMMABILITY RATING UL94-V0
4. PACKAGING: TRAY PACKAGING
5. TEMPERATURE RANGE: -40°C TO +85°C



THIS DOCUMENT CONTAINS PROPRIETARY INFORMATION AND SUCH INFORMATION MAY NOT BE DISCLOSED TO OTHERS FOR ANY PURPOSE OR USED FOR MANUFACTURING PURPOSES WITHOUT WRITTEN PERMISSION FROM AMPHENOL CANADA CORP.

UNLESS SPECIFIED OTHERWISE	DRAWN	P. OU	FEB 07/14
DIMENSIONS ARE IN MILLIMETERS	CHECKED	J. SI	FEB 07/14
REFERENCE IN PARENTHESES	M.E. APP'D		
GENERAL TOLERANCES	Q.A. APP'D		
1 DECIMAL PLACE ±0.25	DWG APP'D	J. SI	FEB 07/14
2 DECIMAL PLACE ±0.15	MATERIAL AND FINISH	SEE NOTES	
3 DECIMAL PLACE N/A	REF.	ECN Exxxxx	
ANGULAR DEGREES ±1°	THIRD ANGLE PROJECTION		
ENG. REL. NO.	DO NOT SCALE DRAWING		

**Amphenol High Speed Interconnects**  
 A Division of Amphenol Corp. www.amphenolcanada.com

**2X4 SFP ULTRAPORT WITH LIGHT PIPE OPTIONS AND EMI SPRING FINGER**

DWG. NO. **P-UE86-3G4620-X0X61** REV **C**

CODE ID NO. 03554 | DWG SIZE: A4 | SCALE: 2:3 | SHEET 1 OF 5

REVISIONS				
REV.	ECN	DESCRIPTION	DATE	APPROVED
A		PROPOSAL	FEB 07/14	J. SI
B		UPDATE PLATING OPTIONS	JUN 25/14	J.SI
C		UPDATE NOTES	AUG 19/14	J.SI

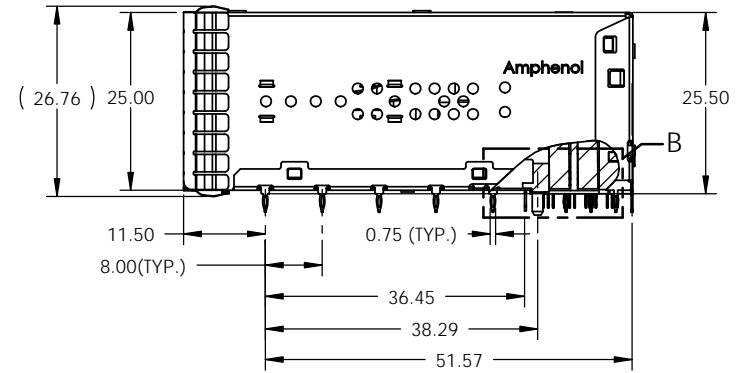
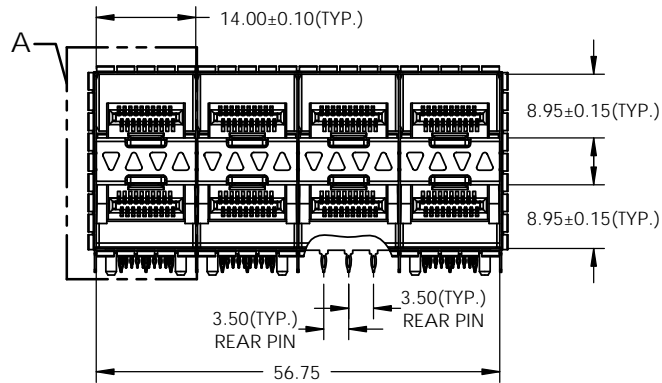
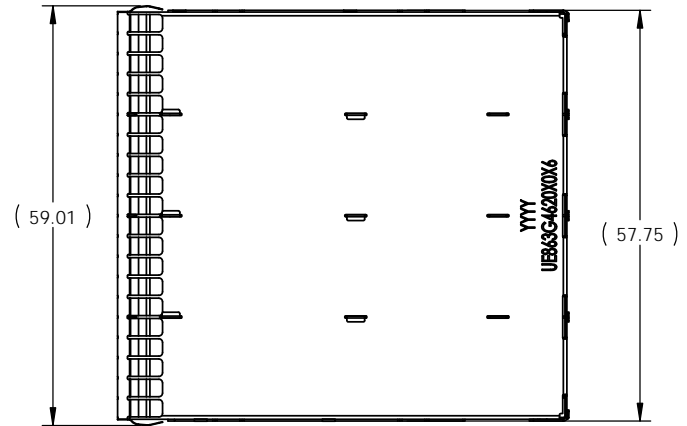
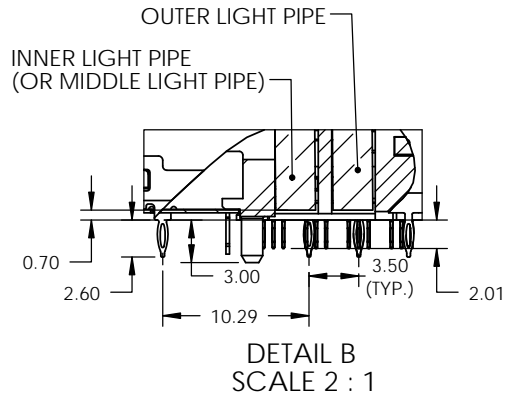
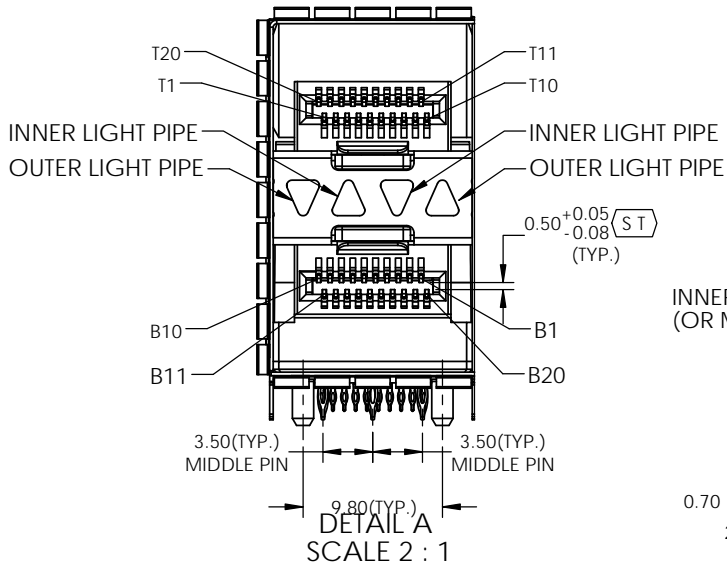

THIS DOCUMENT CONTAINS PROPRIETARY INFORMATION AND SUCH INFORMATION MAY NOT BE DISCLOSED TO OTHERS FOR ANY PURPOSE OR USED FOR MANUFACTURING PURPOSES WITHOUT WRITTEN PERMISSION FROM AMPHENOL CANADA CORP.

UNLESS SPECIFIED OTHERWISE	DRAWN	P. OU	FEB 07/14	<b>Amphenol High Speed Interconnects</b> A Division of Amphenol Corp. www.amphenolcanada.com  <b>2X4 SFP ULTRAPORT WITH LIGHT PIPE            OPTIONS AND EMI SPRING FINGER</b>	DWG. NO. <b>P-UE86-3G4620-X0X61</b>	REV <b>C</b>		
DIMENSIONS ARE IN MILLIMETERS	CHECKED	J. SI	FEB 07/14					
REFERENCE IN PARENTHESES	M.E. APP'D							
GENERAL TOLERANCES	Q.A. APP'D							
1 DECIMAL PLACE ±0.25	DWG APP'D	J. SI	FEB 07/14					
2 DECIMAL PLACE ±0.15	MATERIAL AND FINISH	SEE NOTES						
3 DECIMAL PLACE N/A	REF.	ECN Exxxxx						
ANGULAR DEGREES ±1°	THIRD ANGLE PROJECTION							
ENG. REL. NO.				DO NOT SCALE DRAWING	CODE ID NO. 03554	DWG SIZE: A4	SCALE: 1:1	SHEET 2 OF 5

REVISIONS				
REV.	ECN	DESCRIPTION	DATE	APPROVED
A		PROPOSAL	FEB 07/14	J. SI
B		UPDATE PLATING OPTIONS	JUN 25/14	J.SI
C		UPDATE NOTES	AUG 19/14	J.SI

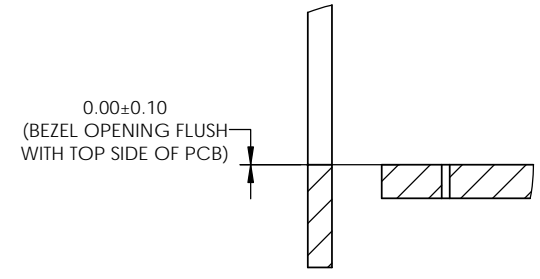
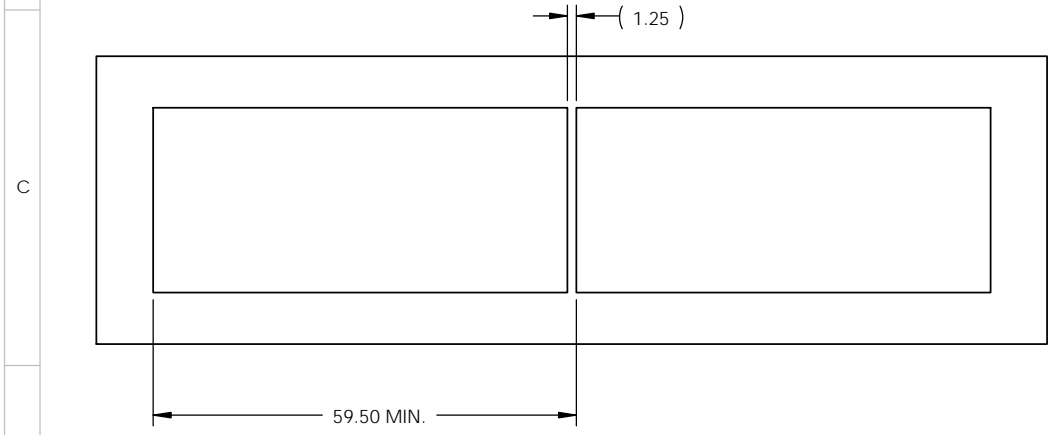
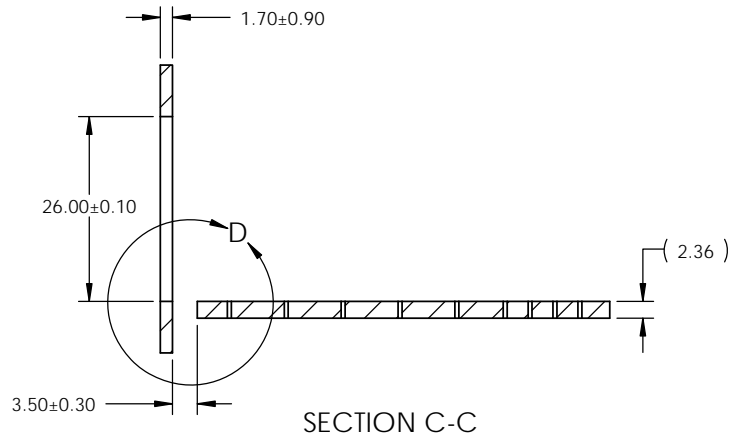
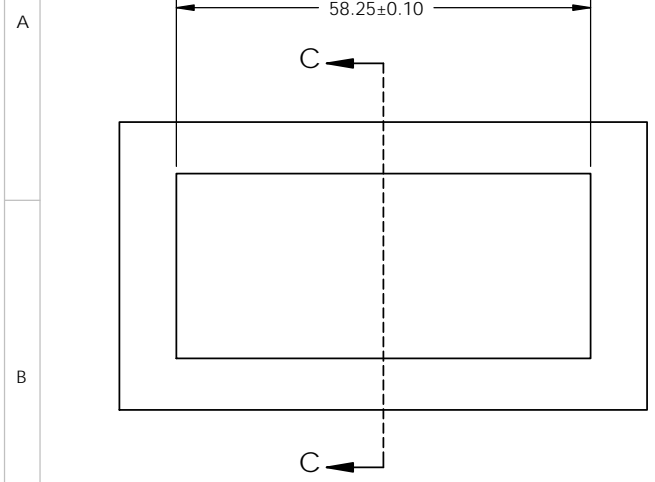

DETAIL D  
SCALE 2 : 1

THIS DOCUMENT CONTAINS PROPRIETARY INFORMATION AND SUCH INFORMATION MAY NOT BE DISCLOSED TO OTHERS FOR ANY PURPOSE OR USED FOR MANUFACTURING PURPOSES WITHOUT WRITTEN PERMISSION FROM AMPHENOL CANADA CORP.

UNLESS SPECIFIED OTHERWISE	DRAWN	P. OU	FEB 07/14	<b>Amphenol High Speed Interconnects</b> A Division of Amphenol Corp. <a href="http://www.amphenolcanada.com">www.amphenolcanada.com</a>			
DIMENSIONS ARE IN MILLIMETERS	CHECKED	J. SI	FEB 07/14				
REFERENCE IN PARENTHESES	M.E. APP'D						
GENERAL TOLERANCES	Q.A. APP'D						
1 DECIMAL PLACE $\pm 0.25$	DWG APP'D	J. SI	FEB 07/14	2X4 SFP ULTRAPORT WITH LIGHT PIPE OPTIONS AND EMI SPRING FINGER			
2 DECIMAL PLACE $\pm 0.15$	MATERIAL AND FINISH	SEE NOTES					
3 DECIMAL PLACE N/A	REF.	ECN Exxxxx		DWG. NO.	P-UE86-3G4620-X0X61	REV	C
ANGULAR DEGREES $\pm 1^\circ$	THIRD ANGLE PROJECTION	DO NOT SCALE DRAWING		CODE ID NO.	03554	DWG SIZE:	A4
ENG. REL. NO.				SCALE:	1:1	SHEET	3 OF 5

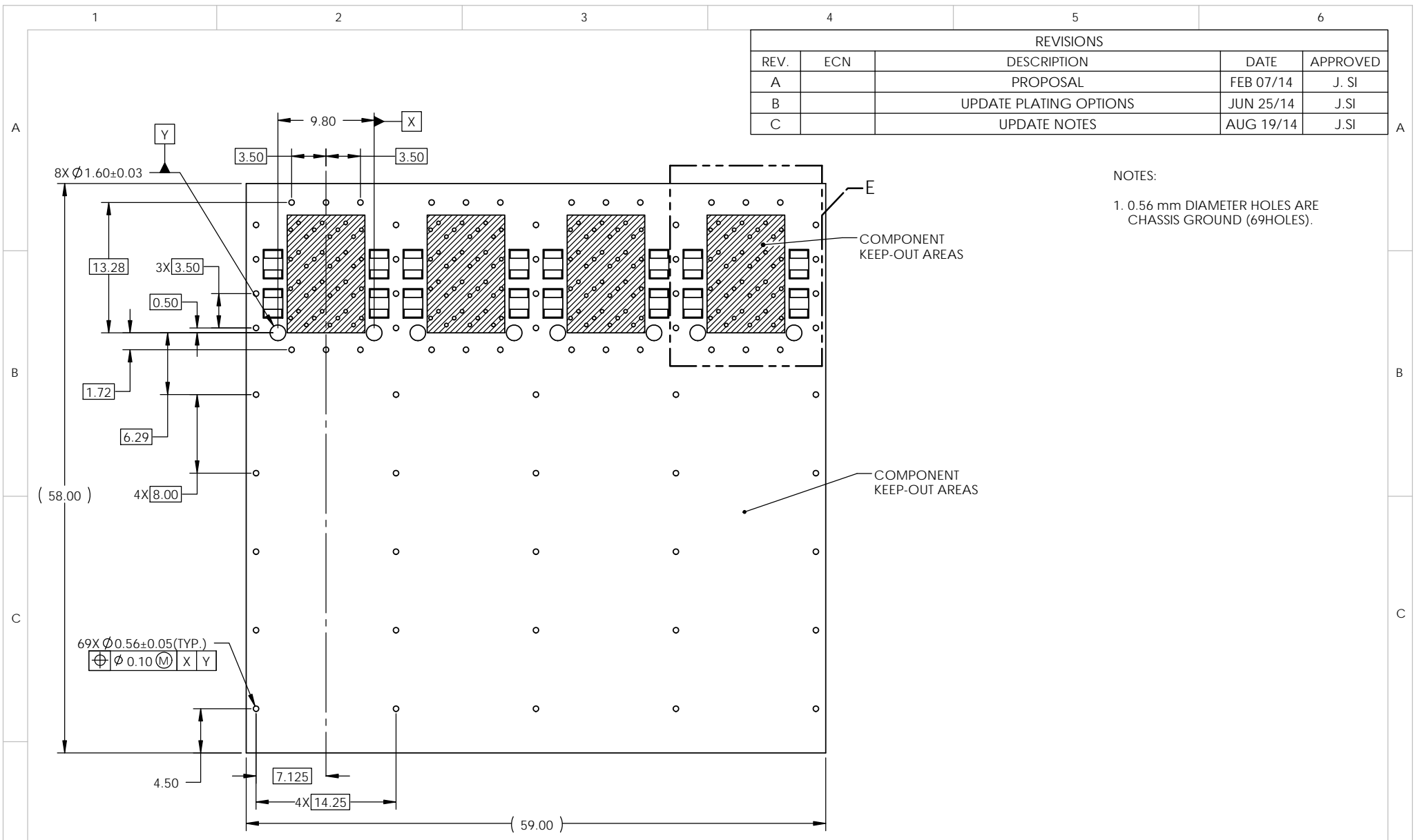

REVISIONS				
REV.	ECN	DESCRIPTION	DATE	APPROVED
A		PROPOSAL	FEB 07/14	J. SI
B		UPDATE PLATING OPTIONS	JUN 25/14	J.SI
C		UPDATE NOTES	AUG 19/14	J.SI

NOTES:  
 1. 0.56 mm DIAMETER HOLES ARE CHASSIS GROUND (69HOLES).

**2X4 PCB LAYOUT**

THIS DOCUMENT CONTAINS PROPRIETARY INFORMATION AND SUCH INFORMATION MAY NOT BE DISCLOSED TO OTHERS FOR ANY PURPOSE OR USED FOR MANUFACTURING PURPOSES WITHOUT WRITTEN PERMISSION FROM AMPHENOL CANADA CORP.

UNLESS SPECIFIED OTHERWISE		DRAWN	P. OU	FEB 07/14	<b>Amphenol High Speed Interconnects</b> A Division of Amphenol Corp. www.amphenolcanada.com
DIMENSIONS ARE IN MILLIMETERS		CHECKED	J. SI	FEB 07/14	
REFERENCE IN PARENTHESES		M.E. APP'D			
GENERAL TOLERANCES		Q.A. APP'D			<b>2X4 SFP ULTRAPORT WITH LIGHT PIPE          OPTIONS AND EMI SPRING FINGER</b>
1 DECIMAL PLACE	±0.25	DWG APP'D	J. SI	FEB 07/14	
2 DECIMAL PLACE	±0.15	MATERIAL AND FINISH	SEE NOTES		
3 DECIMAL PLACE	N/A	REF.	ECN Exxxxx		
ANGULAR DEGREES	±1°	THIRD ANGLE PROJECTION			
ENG. REL. NO.		DO NOT SCALE DRAWING			

DWG. NO. P-UE86-3G4620-X0X61  
 CODE ID NO. 03554 DWG SIZE: A4 SCALE: 2:1 SHEET 4 OF 5

REVISIONS				
REV.	ECN	DESCRIPTION	DATE	APPROVED
A		PROPOSAL	FEB 07/14	J. SI
B		UPDATE PLATING OPTIONS	JUN 25/14	J.SI
C		UPDATE NOTES	AUG 19/14	J.SI

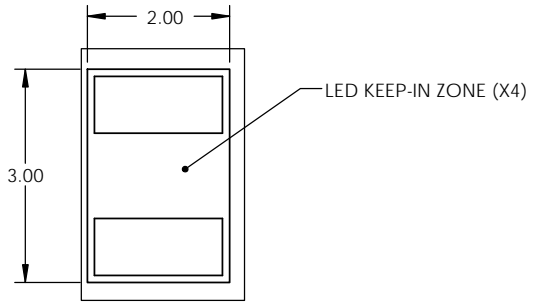
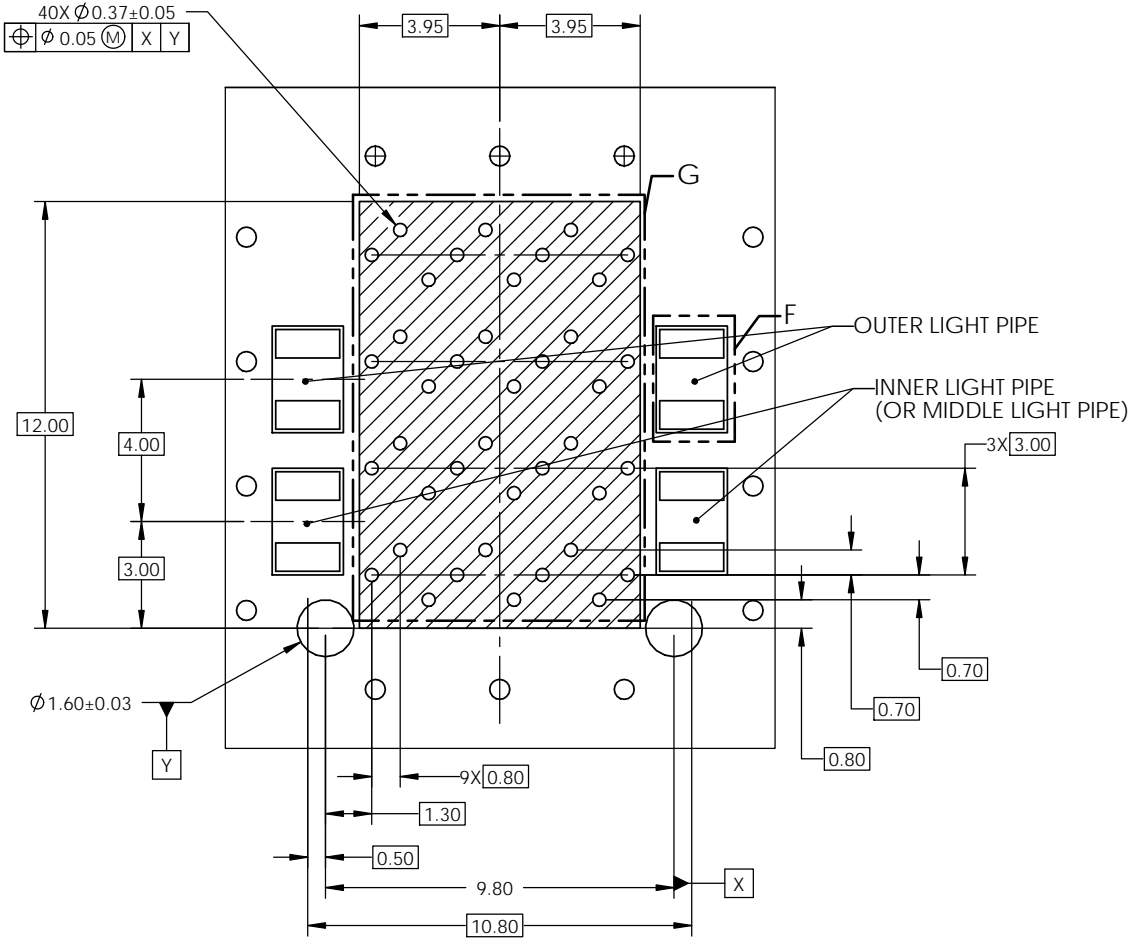

DETAIL F  
SCALE 10 : 1

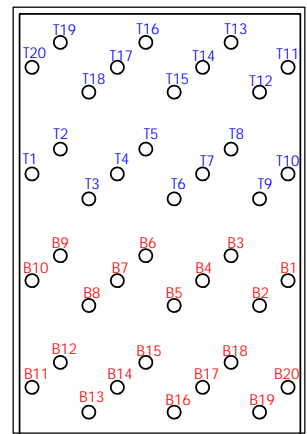

DETAIL G  
SCALE 5 : 1

DETAIL E  
SCALE 5 : 1

THIS DOCUMENT CONTAINS PROPRIETARY INFORMATION AND SUCH INFORMATION MAY NOT BE DISCLOSED TO OTHERS FOR ANY PURPOSE OR USED FOR MANUFACTURING PURPOSES WITHOUT WRITTEN PERMISSION FROM AMPHENOL CANADA CORP.

UNLESS SPECIFIED OTHERWISE DIMENSIONS ARE IN MILLIMETERS REFERENCE IN PARENTHESES GENERAL TOLERANCES 1 DECIMAL PLACE ±0.25 2 DECIMAL PLACE ±0.15 3 DECIMAL PLACE N/A ANGULAR DEGREES ±1° ENG. REL. NO.	DRAWN	P. OU	FEB 07/14	<b>Amphenol High Speed Interconnects</b> A Division of Amphenol Corp. www.amphenolcanada.com  <b>2X4 SFP ULTRAPORT WITH LIGHT PIPE          OPTIONS AND EMI SPRING FINGER</b>	DWG. NO. <b>P-UE86-3G4620-X0X61</b>	REV <b>C</b>	
	CHECKED	J. SI	FEB 07/14				
	M.E. APP'D						
	Q.A. APP'D						
	DWG APP'D	J. SI	FEB 07/14				
MATERIAL AND FINISH	SEE NOTES			CODE ID NO. 03554	DWG SIZE: A4	SCALE: 2:1	SHEET 5 OF 5
REF.	ECN Exxxxx						
THIRD ANGLE PROJECTION	DO NOT SCALE DRAWING						



## Стандарт Электрон Связь

Мы молодая и активно развивающаяся компания в области поставок электронных компонентов. Мы поставляем электронные компоненты отечественного и импортного производства напрямую от производителей и с крупнейших складов мира.

Благодаря сотрудничеству с мировыми поставщиками мы осуществляем комплексные и плановые поставки широчайшего спектра электронных компонентов.

Собственная эффективная логистика и склад в обеспечивает надежную поставку продукции в точно указанные сроки по всей России.

Мы осуществляем техническую поддержку нашим клиентам и предпродажную проверку качества продукции. На все поставляемые продукты мы предоставляем гарантию .

Осуществляем поставки продукции под контролем ВП МО РФ на предприятия военно-промышленного комплекса России , а также работаем в рамках 275 ФЗ с открытием отдельных счетов в уполномоченном банке. Система менеджмента качества компании соответствует требованиям ГОСТ ISO 9001.

Минимальные сроки поставки, гибкие цены, неограниченный ассортимент и индивидуальный подход к клиентам являются основой для выстраивания долгосрочного и эффективного сотрудничества с предприятиями радиоэлектронной промышленности, предприятиями ВПК и научно-исследовательскими институтами России.

С нами вы становитесь еще успешнее!

### Наши контакты:

**Телефон:** +7 812 627 14 35

**Электронная почта:** [sales@st-electron.ru](mailto:sales@st-electron.ru)

**Адрес:** 198099, Санкт-Петербург,  
Промышленная ул, дом № 19, литера Н,  
помещение 100-Н Офис 331