



# Reference Manual

---

## Mpression USB 3.0 Interface Card SV

Revision 1.2

2017/01/12

© Mpression – Solutions by Macnica Group

## Disclaimer

The information in this document (hereinafter called “Information”) is subject to change without notice.

Macnica Inc. (hereinafter called “Manufacturer”) makes no warranty of any kind regarding this document, or of any liability arising out of the application or use of information in this document, and assumes no responsibility for any errors that may appear in this document.

This document is distributed without any charge and reselling or copying without written authorization by Manufacturer is restricted.

IN NO EVENT WILL MANUFACTURER BE LIABLE FOR ANY CONSEQUENTIAL, INDIRECT, EXEMPLARY, SPECIAL, OR INCIDENTAL DAMAGES, INCLUDING ANY LOST DATA AND LOST PROFITS, ARISING FROM OR RELATING TO YOUR USE OF THE INFORMATION, EVEN IF YOU HAVE BEEN ADVISED OF THE POSSIBILITY OF SUCH DAMAGES. THE TOTAL CUMULATIVE LIABILITY OF MANUFACTURER IN CONNECTION WITH YOUR USE OF THE INFORMATION IN THIS DOCUMENT, WHETHER IN CONTRACT OR TORT OR OTHERWISE, WILL IN NO EVENT EXCEED THE AMOUNT OF FEES PAID BY YOU TO MANUFACTURER HEREUNDER FOR USE OF THE INFORMATION. YOU ACKNOWLEDGE THAT THE FEES, IF ANY, REFLECT THE ALLOCATION OF RISK SET FORTH IN THIS AGREEMENT AND THAT MANUFACTURER WOULD NOT MAKE AVAILABLE THE INFORMATION TO YOU WITHOUT THESE LIMITATIONS OF LIABILITY.

The Information is not intended for use in the development of on-line control equipment in hazardous environments requiring failsafe controls, such as in the operation of nuclear facilities, aircraft navigation or communications systems, air traffic control, life support, or weapons systems (“High-Risk Applications”). Manufacturer specifically disclaims any express or implied warranties of fitness for such High-Risk Applications. You represent that use of the Information in such High-Risk Applications is fully at your risk.



# Contents

<b>1. For Ensuring Safe Use</b>	<b>4</b>
1.1 Legend	4
1.2 Cautions	4
1.3 Developer Information	6
1.4 Inquiries	6
<b>2. Introduction</b>	<b>7</b>
2.1 Before Use	7
<b>3. Functions and Features</b>	<b>8</b>
3.1 Key Features	8
3.2 Layout	10
3.3 Hardware Specifications	11
<b>4. When Using this Card</b>	<b>15</b>
4.1 Instructions and precautions for use of this card	15
4.2 Mode selection for unused pins	15
4.3 Pin Assignment	17
<b>5. Document Revision History</b>	<b>19</b>



# 1. For Ensuring Safe Use



Be sure to follow the instructions given in this Manual which are intended to prevent harm to the user and others as well as material damage.

## 1.1 Legend

 <b>Danger</b>	Indicates an imminent hazardous situation which if not avoided will result in death or serious injury.
 <b>Warning</b>	Indicates a potentially hazardous situation which if not avoided could result in death or serious injury.
 <b>Caution</b>	Indicates a potentially hazardous situation which if not avoided may result in minor or moderate injury or in property damage.

## 1.2 Cautions

 <b>Danger</b>	<p>Make sure to use the AC adapter (if uses or required) that is specified in this Manual or included one in package.</p> <p>Using an AC adapter not meeting the specifications described in this Manual will cause the kit to emit heat, explode, or ignite.</p>
 <b>Warning</b>	<p>Do not apply strong impacts or blows to the kit.</p> <p>Doing so may cause the kit to emit heat, explode, or ignite, or the equipment in the kit to fail or malfunction. This may also cause fire.</p>
	<p>Do not put the main unit or the AC adapter in cooking appliances such as microwave ovens, or high-pressure containers.</p> <p>Doing so might cause the main unit or AC adapter to emit heat, explode, ignite, or emit smoke, or its parts to break or warp.</p>
	<p>Do not wrap the main unit that is in use with cloth or other materials that are likely to allow heat to build up inside the wrapping.</p> <p>This will cause heat to build up inside the wrapping which may cause the main unit to ignite or malfunction.</p>
	<p>When disposing of the main unit, do not dispose of it along with general household waste.</p> <p>Throwing the main unit into fire may cause it to explode. Dispose of the main unit following the laws, regulations, and ordinances governing waste disposal.</p> <p>Do not use the kit in places subject to extremely high or low temperatures or severe temperature changes.</p> <p>Doing so may cause the kit to fail or to malfunction.</p> <p>Always be sure to use the kit in a temperatures ranging from 5°C to 35°C and a humidity range of 0% to 85%.</p>

 <p><b>Warning</b> (Continued from previous page)</p>	<p>Do not pull the power supply cable with excessive force or place heavy items on it. Do not damage, break, bundle, or tamper with the power supply cable. Damaged parts of the power supply cable might cause a short circuit resulting in fire or accidents involving electrical shock.</p>
	<p>Do not unplug the power plug with wet or moist hands. This might cause injuries or equipment malfunctions or failures due to electrical shock.</p>
	<p>Plug the power plug securely into the outlet. If the power plug is not securely plugged into the outlet, it may cause accidents involving electrical shock or fire due to heat emitted.</p>
	<p>Do not connect many electrical cords to a single socket or connect an AC adapter to an outlet that is not rated for the specified voltage. Failing to do so may cause the equipment to malfunction or fail, or lead to accidents involving electrical shock or fire due to heat emitted.</p>
	<p>Periodically remove any dust accumulated on the power plug and around the outlet (socket). Do not use a power plug with dust accumulated on it because doing so will lead to insulation failure due to moisture which may lead to fire. Remove any dust on the power plug and around the outlet with dried cloth.</p>
	<p>Do not place any containers such as cups or vases filled with water or other liquid on this Board. If this Board is exposed to water or other liquids it may cause the Board to malfunction or lead to accidents involving electrical shock. If you spilled water or other liquid on this Board, immediately stop using the Board, turn off the power, and unplug the power plug. If you have any requests for repairs or technical consultation, please contact the Manufacturer.</p>
 <p><b>Caution</b></p>	<p>Do not place the kit on unstable places such as shaky stands or tilted locations. Doing so may cause injuries or cause this Board to malfunction if the Board should fall.</p>
	<p>Do not attempt to use or leave the kit in places subject to strong direct sunlight or other places subject to high temperatures such as in cars in hot weather. Doing so might cause the kit to emit heat, break, ignite, run out of control, warp, or malfunction. Also, some parts of the equipment might emit heat causing burn injuries.</p>
	<p>Unplug the power supply cable when carrying out maintenance of devices in which the main unit is embedded. Failure to do so may lead to accidents involving electrical shock.</p>
	<p>Do not place this Board in locations where excessive force is applied to the Board. Failure to do so may cause the PC board to warp, leading to breakage of the PC board, missing parts or malfunctioning parts.</p>
	<p>When using the kit together with expansion boards or other peripheral devices, be sure to carefully read each of their manuals and to use them correctly. Manufacturer does not guarantee the operation of specific expansion boards or peripheral devices when used in conjunction with this Board unless they are specifically mentioned in this Manual or their successful operation with this Board has been confirmed in separate documents.</p>
	<p>Be sure to turn off the power switch when moving this Board to connect to other devices. Failure to do so may cause this Board to fail or lead to accidents involving electrical shock.</p>

 <p><b>Caution</b> (Continued from previous page)</p>	<p>Do not clean this Board by using a rag containing chemicals such as benzine or thinner. Failure to do so will likely cause this Board to deteriorate. When using a chemical cloth be sure to comply with any directions or warnings.</p>
	<p>Do not immediately turn on the power if you find that water or moisture had condensed onto the main unit after removing the board from the package. Condensation might occur on this Board when taking it out of the box, if the board is cool yet the room temperature is warm.</p> <p>Do not apply power to the Board while water or moisture has condensed on it because the moisture may cause the Board to break or may shorten the service life of the parts.</p> <p>When you first take this Board out of the box be sure to leave it at room temperature for a while before using it. If condensation or moisture has occurred on this Board, first wait for the moisture to fully evaporate before installing or connecting the Board to other devices.</p>
	<p>Do not disassemble, dismantle, modify, alter, or recycle parts unless they are clearly described as customizable in this Manual.</p> <p>Although this kit is customizable, if parts not specified in this Manual as customizable are modified in any way, then the overall product operation cannot be guaranteed.</p> <p>Please consult with Manufacturer beforehand if you wish to customize or modify any parts that are not described in this Manual as customizable.</p>

## 1.3 Developer Information

The Developer of this product is:

Altima Corp.

1-5-5 Shin-Yokohama, Kouhoku-ku, Yokohama, 222-8563 JAPAN

<http://www.altima.co.jp>

## 1.4 Inquiries

In case you have any inquiries about the use this product, please contact your local Macnica company or make inquiries through the contact form in the following web site:

<http://www.m-pression.com/contact>

Macnica companies:

- |                  |                       |   |
|------------------|-----------------------|---|
| • China & HK:    | Cytech Technology     | <a href="http://www.cytech.com/">http://www.cytech.com/</a>                     |
| • ASEAN & India: | Cytech Global         | <a href="http://www.cytechglobal.com/">http://www.cytechglobal.com/</a>         |
| • Taiwan:        | Galaxy Far East Corp. | <a href="http://www.gfec.com.tw/">http://www.gfec.com.tw/</a>                   |
| • North America: | Macnica Americas      | <a href="http://www.macnica-na.com/">http://www.macnica-na.com/</a>             |
| • Brazil:        | Macnica DHW           | <a href="http://www.macnicadhw.com.br/en/">http://www.macnicadhw.com.br/en/</a> |
| • Japan:         | Altima                | <a href="http://www.altima.co.jp">http://www.altima.co.jp</a>                   |
|                  | Elsena                | <a href="http://www.elsena.co.jp">http://www.elsena.co.jp</a>                   |

## 2. Introduction

Thank you for purchasing our UBS 3.0 Interface Card SV (hereinafter, this Card).

This manual “Reference Manual—USB 3.0 Interface Card SV” (hereinafter, this Manual) includes instructions for use of this Card for connection to the HSMC port of ALTERA’s development kit. Before using this Card, carefully read this Manual and be sure to use this Card correctly. Be sure to keep this Manual and Card together.

### 2.1 Before Use

Make sure all of the following items are included.

USB 3.0 Interface Card SV : 1set	
Standard A to Micro B Plug cable (50cm) : 1pc ( Manufactured by Bando Electric Wire)	
Spacer : 2 sets	
Package List/Precautions	
The manuals and other documents shown to the right are available at the URL specified in the “Package List/Precautions.”	This Manual
	Schematic for this Card
	Reference Design for USB 3.0 Interface Card SV
	Getting Started for USB 3.0 Interface Card SV

After opening the package, check that all items are included and check for damage. If any item is missing or any visible damage is found, contact our sales personnel within 30 days of receiving the package.

## 3. Functions and Features

### 3.1 Key Features

This Card is a daughter card that can be mounted on an HSMC and has a board that can be used with an FPGA development board equipped with an HSMC.

- With this Board, users can develop and test USB 3.0 functions by using the Altera FPGA and Cypress EZ-USB® FX3.

#### 3.1.1 Basic Specification

The product specifications of this Card are as follows:

製品仕様	ALTHSMCUSB3SV
USB 3.0 device	Cypress EZ-USB® FX3 (CYUSB3014-BZXI)
Power supply	DC 12V 1A
Dimensions	120mm x 78.105mm
HSMC	Samtec ASP-122952-01
PC board	FR4 8Layers
I2C EEPROM	ATMEL AT24C1024W-10SU-2.7 or equivalent
Clock	RIVER ELETEC FCXO-05 19.2MHz RIVER ELETEC FCXO-05D 32.768kHz
FX3 JTAG header	DIP 20pin header 2.54mm pitch
USB3.0 Micro connector	HOSIDEN CMS1811-010010
UART	Norcomp Inc 182-009-213R181 or equivalent
Power LED	5pcs ( 1.2V, 2.5V, 3.3V, 5V, 12V )
RESET Push SW	Panasonic EVQPAC07K or equivalent( for FX3 RESET)
Power Selection SW	DAIWA MCS131EA-1004 or equivalent



### 3.1.2 Block diagram of this card

#### 1.1.1 USB 3.0 Interface card SV block diagram

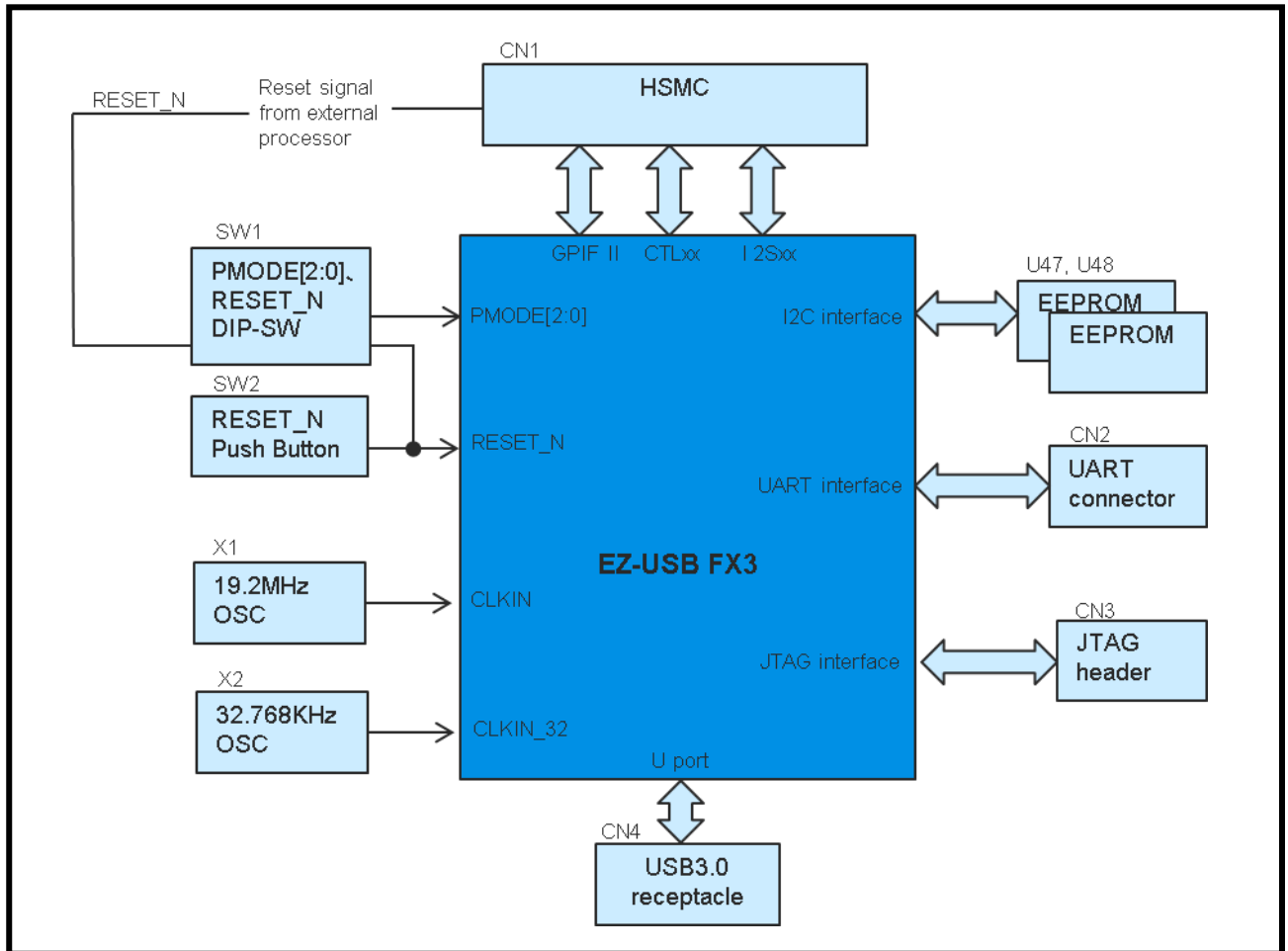

Fig. 3-1 Block Diagram

## 3.2 Layout

### 3.2.1 Layout and component name

Fig. 3-2 shows each component layout on this card

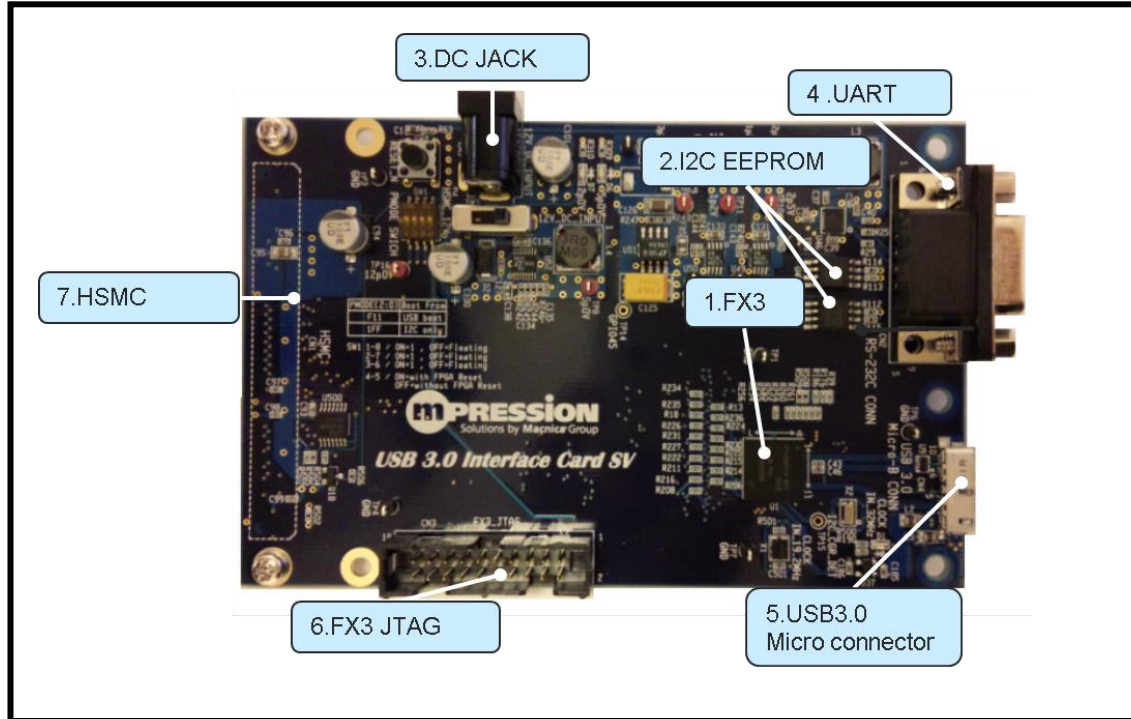

Fig. 3-2 Layout

- |                        |                           |
|------------------------|---------------------------|
| 1. Cypress EZ-USB® FX3 | 5. USB3.0 Micro connector |
| 2. I2C EEPROM          | 6. FX3 JTAG               |
| 3. DC JACK             | 7. HSMC                   |
| 4. UART                |                           |

### 3.3 Hardware Specifications

#### 3.3.1 Connector pin assignment

Fig. 3-3 shows connector layout

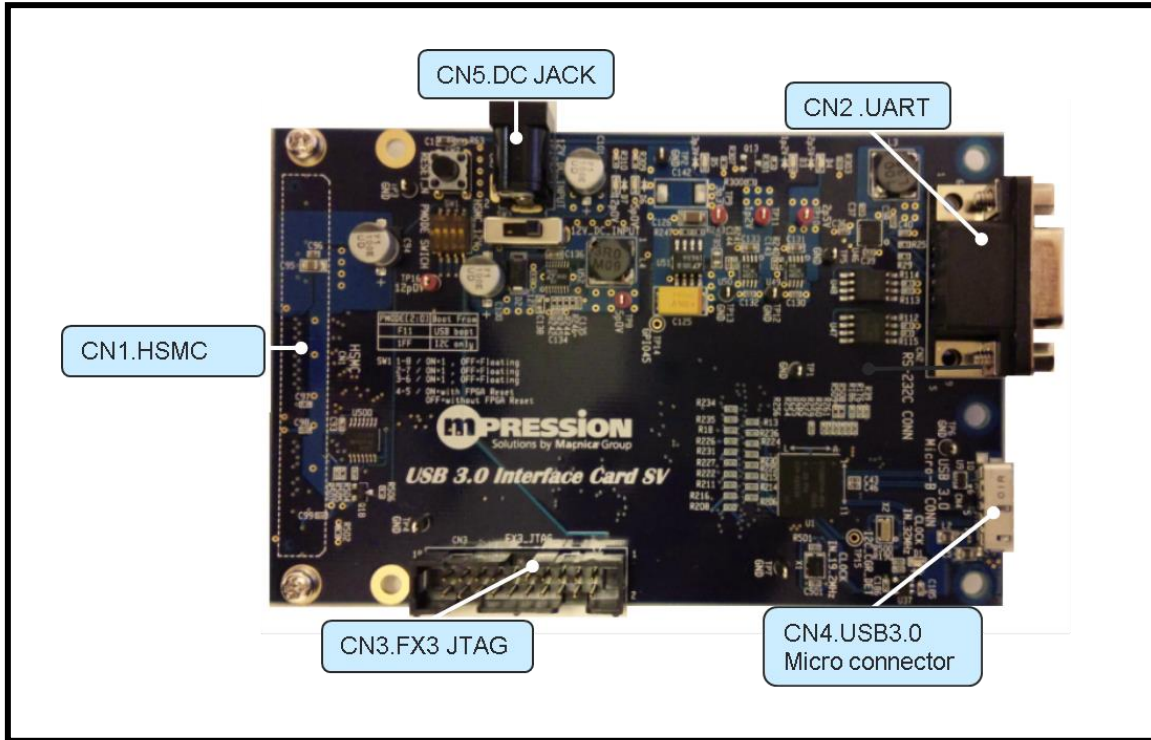

Fig. 3-3 Connector Layout

01. CN5 ( DC Jack)

Pin #	Pin Name	Pin #	Pin Name
1	12V DC INPUT	2	GND
3	GND		



02. CN2 (UART)

Pin #	Pin Name	Pin #	Pin Name
1		2	TX_OUT
3	RX_IN	4	
5	GND	6	
7		8	
9			

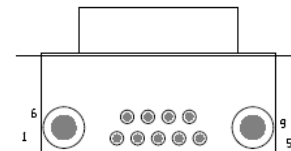

03. CN4 ( USB 3.0 Micro Connector )

Pin #	Pin Name	Pin #	Pin Name
1	VBUS_IN	2	SS_DM
3	SS_DP	4	OTG_ID
5	GND	6	SS_TX_M
7	SS_TX_P	8	GND
9	SS_RX_P	10	SS_RX_M
11	SHIELD(GND)	12	SHIELD(GND)
13	SHIELD(GND)	14	SHIELD(GND)
15	SHIELD(GND)	16	SHIELD(GND)
17	SHIELD(GND)	18	SHIELD(GND)

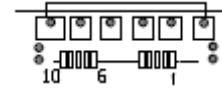

04. CN3 ( FX3 JTAG )

Pin #	Pin Name	Pin #	Pin Name
1	2.5V	2	2.5V
3	TRST_N	4	GND
5	TDI	6	GND
7	TMS	8	GND
9	TCK	10	GND
11	RTCK(GND)	12	GND
13	TDO	14	GND
15	N_SRST(NC)	16	GND
17	NC	18	GND
19	NC	20	GND



05. CN1 ( HSMC )

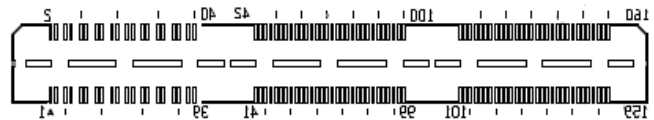

Pin#	Pin Name	Pin#	Pin Name	Pin#	Pin Name	Pin#	Pin Name
1		2		47	DQ4	48	DQ5
3		4		49	DQ6	50	DQ7
5		6		51		52	12V
7		8		53	DQ8	54	DQ9
9		10		55	DQ10	56	DQ11
11		12		57		58	12V
13		14		59	DQ12	60	DQ13
15		16		61	DQ14	62	DQ15
17		18		63		64	12V
19		20		65	DQ16	66	DQ17
21		22		67	DQ18	68	DQ19
23		24		69		70	12V
25		26		71	DQ20	72	DQ21
27		28		73	DQ22	74	DQ23
29		30		75		76	12V
31		32		77	DQ24	78	DQ25
33		34		79	DQ26	80	DQ27
35		36		81		82	12V
37		38		83	DQ28	84	DQ29
39		40		85	DQ30	86	DQ31
41	DQ0	42	DQ1	87		88	12V
43	DQ2	44	DQ3	89		90	
45		46	12V	91		92	

05. CN1 ( HSMC )(Continued)

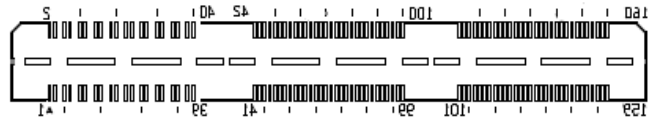

Pin#	Pin Name	Pin#	Pin Name	Pin#	Pin Name	Pin#	Pin Name
93		94	12V	133	I2S_CLK	134	
95		96	GND	135		136	12V
97		98	GND	137		138	
99		100	12V	139		140	
101	CTL0	102	CTL1	141		142	12V
103	CTL2	104	CTL3	143	PCLK	144	I2S_MCLK
105		106	12V	145		146	
107	CTL4	108	CTL5	147		148	12V
109	CTL6	110	CTL7	149		150	
111		112	12V	151		152	
113	CTL8	114	CTL9	153		154	12V
115	CTL10	116	CTL11	155		156	GND
117		118	12V	157		158	GND
119	CTL12	120		159		160	GND
121		122		161	GND	162	GND
123		124	12V	163	GND	164	GND
125	INT_N_CTL15	126	RESET_N	165	GND	166	GND
127		128		167	GND	168	GND
129		130	12V	169	GND	170	GND
131	I2S_WP	132	I2S_SD	171	GND	172	GND

### 3.3.2 Switch Specifications

Fig. 3-4 shows switch layout

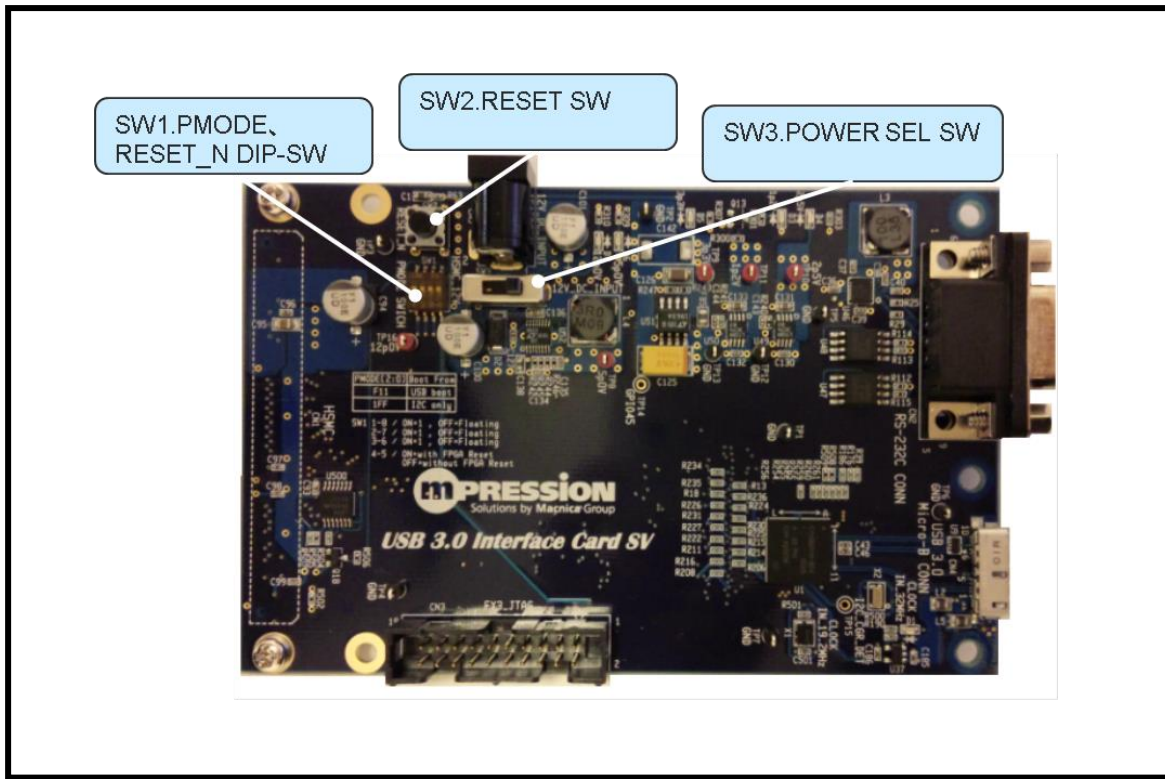

Fig. 3-4 switch layout

On the table below, describes each switch function

Location	Function	Default Value	Description
SW1	PMODE, RESET_N DIP-SW	SW1[4:1] =>OFF,OFF,ON,ON	SW1[4] => RESET_N: ON => Reset call from FPGA SW1[4] => RESET_N: OFF => No reset call from FPGA W1[3:1] => PMODE[2:0]: OFF,ON,ON => USB Boot SW1[3:1] => PMODE[2:0]: ON,OFF,OFF => I2C Only
SW2	RESET SW	—	PUSH => Reset FX3
SW3	POWER SEL SW	HSMC_12V	HSMC_12V => 12V power supply via HSMC 12V_DC_INPUT => 12V power supply from DC JACK

## 4. When Using this Card

---

### 4.1 Instructions and precautions for use of this card

The following describes instructions and precautions for use of this Card.

#### 4.1.1 Power Supply

The power on this card can be turned on by either of the following two methods:

- Connect this card to HSMC connector of ALTERA development kit, then it is possible to be provided 12V power supply via HSMC

**NOTE: In a case of power supply via HSMC, POWER SEL SW(SW3) should be set to “HSMC\_12V” side**

- Another method is using optional AC adaptor. If customer prepare or purchase an optional AC adaptor which is 12V & 1A specification, this card will be provided 12V power supply when AC adaptor is connected to DC JACK(CN5)

**NOTE: Under this use case, POWER SEL SW(SW3) should be set to “12V\_DC\_INPUT” side. PLEASE DO NOT use this card with ALTERA development kit under “12V\_DC\_INPUT” mode, this mode is stand-alone evaluation purpose for this card.**

Since default setting of factory mode is set to “HSMC\_12V”, each power LED(D7-D3) is turned on by power-on ALTERA development kit.

If the above LED does not light up, please contact the sales company.

### 4.2 Mode selection for unused pins

To prevent malfunctions, it is recommended that those pins not in use (unused pins) on the hardware design of an FPGA be set to tri-state mode as follows:

1. Select the **Assignments** menu, and then **Device**.
2. Click the **Device & Pin Options** button.  
The **Device & Pin Options** window appears.
3. From the **Category** window, select **Unused Pins**.
4. From the **Reserve all unused pins** item, select: **As input tri-stated**.
5. Click the **OK** button.
6. Click the **OK** button to close the **Device & Pin Options** window.

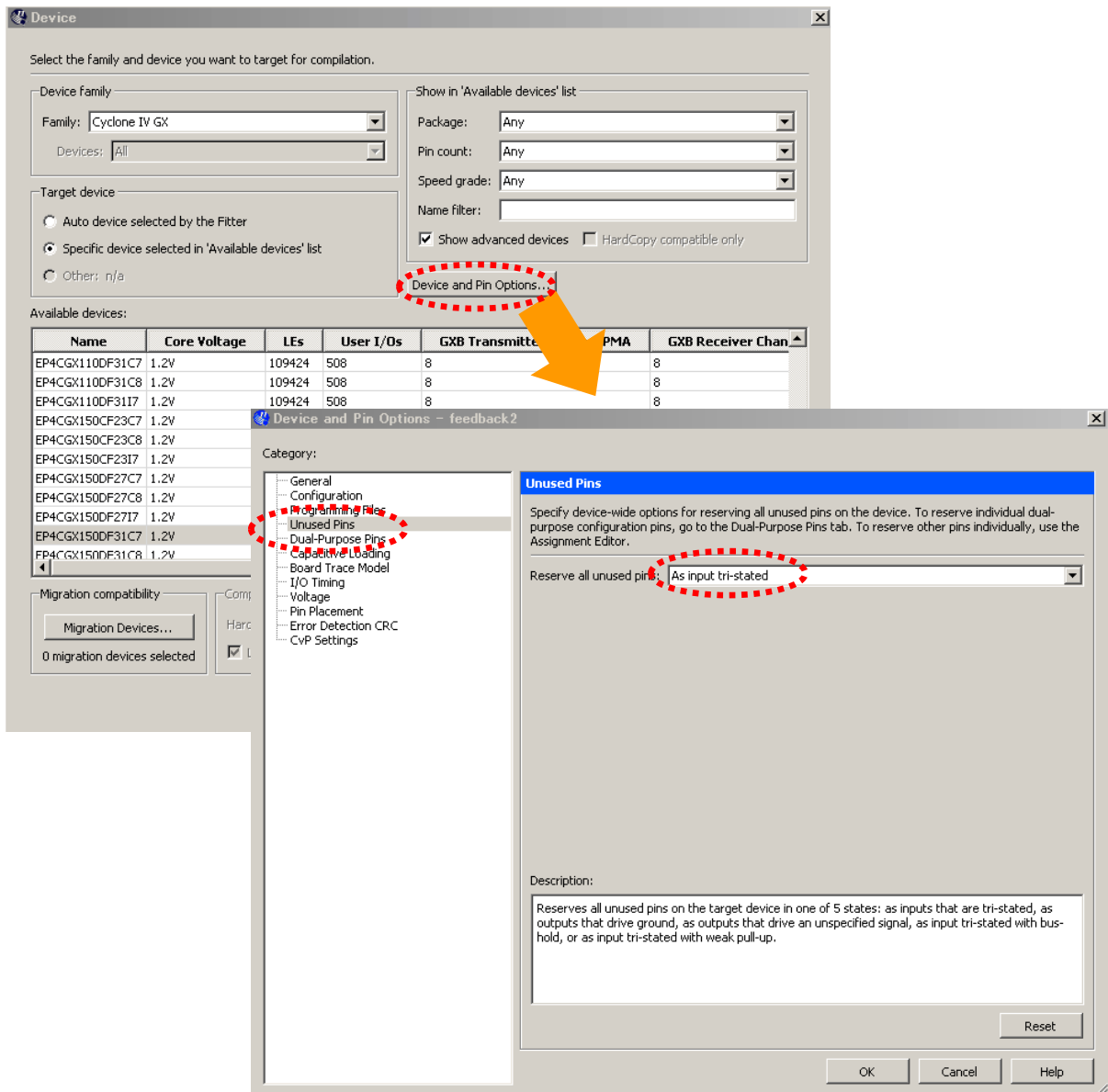

Fig. 4-1 Mode selection for unused pins



## 4.3 Pin Assignment

This section describes the assignment of the HSMC and FX3 pins.

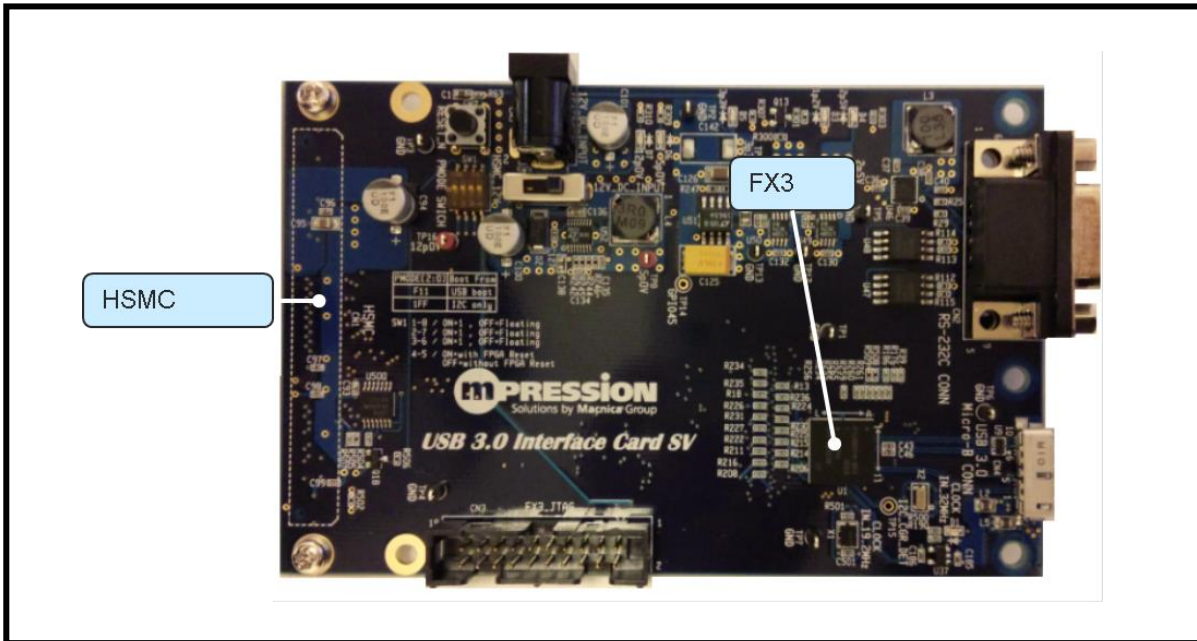

Fig. 4-2 HSMC and FX3 assignment

On the table below describes pin assignment between HSMC and FX3

Signal Name	FX3 Pin#	HSMC Connector Pin #	Signal Name	FX3 Pin#	HSMC Connector Pin #
DQ0	F10	41	DQ10	K11	55
DQ1	F9	42	DQ11	L10	56
DQ2	F7	43	DQ12	K10	59
DQ3	G10	44	DQ13	K9	60
DQ4	G9	47	DQ14	J8	61
DQ5	F8	48	DQ15	G8	62
DQ6	H10	49	DQ16	K2	65
DQ7	H9	50	DQ17	J4	66
DQ8	J10	53	DQ18	K1	67
DQ9	J9	54	DQ19	J2	68
DQ10	K11	55	DQ20	J3	71

( Continued to next page )

Signal Name	FX3 Pin#	HSMC Connector Pin #	Signal Name	FX3 Pin#	HSMC Connector Pin #
DQ21	J10	72	CL4	G7	107
DQ22	H2	73	CL5	G6	108
DQ23	H3	74	CL7	H8	110
DQ24	F4	77	CL8	G5	113
DQ25	G2	78	CL9	H6	114
DQ26	G3	79	CL10	K5	115
DQ27	F3	80	CL11	J5	116
DQ28	F5	83	CL12	H5	119
DQ29	E1	84	INT_N_CTL15	L8	125
DQ30	E5	85	RESET_N_CON	C5	126
DQ31	E4	86	I2S_WP	D3	131
CL0	K8	101	I2S_SD	D2	132
CL1	K7	102	I2S_CLK	D1	133
CL2	J7	103	PCLK	J6	143
CL3	H7	104	I2S_MCLK	C4	144

## 5. Document Revision History

---

Date	Revision	Changes
2014/03/01	1.0	Document released
2014/04/25	1.1	HSMC pin assignment update
2017/01/12	1.2	Change OSC Sitime -> RiverEletec Abracon -> RiverEletec



## Стандарт Электрон Связь

Мы молодая и активно развивающаяся компания в области поставок электронных компонентов. Мы поставляем электронные компоненты отечественного и импортного производства напрямую от производителей и с крупнейших складов мира.

Благодаря сотрудничеству с мировыми поставщиками мы осуществляем комплексные и плановые поставки широчайшего спектра электронных компонентов.

Собственная эффективная логистика и склад в обеспечивает надежную поставку продукции в точно указанные сроки по всей России.

Мы осуществляем техническую поддержку нашим клиентам и предпродажную проверку качества продукции. На все поставляемые продукты мы предоставляем гарантию .

Осуществляем поставки продукции под контролем ВП МО РФ на предприятия военно-промышленного комплекса России , а также работаем в рамках 275 ФЗ с открытием отдельных счетов в уполномоченном банке. Система менеджмента качества компании соответствует требованиям ГОСТ ISO 9001.

Минимальные сроки поставки, гибкие цены, неограниченный ассортимент и индивидуальный подход к клиентам являются основой для выстраивания долгосрочного и эффективного сотрудничества с предприятиями радиоэлектронной промышленности, предприятиями ВПК и научно-исследовательскими институтами России.

С нами вы становитесь еще успешнее!

### Наши контакты:

**Телефон:** +7 812 627 14 35

**Электронная почта:** [sales@st-electron.ru](mailto:sales@st-electron.ru)

**Адрес:** 198099, Санкт-Петербург,  
Промышленная ул, дом № 19, литера Н,  
помещение 100-Н Офис 331