

Low voltage high performance NPN power transistor

Datasheet - preliminary data

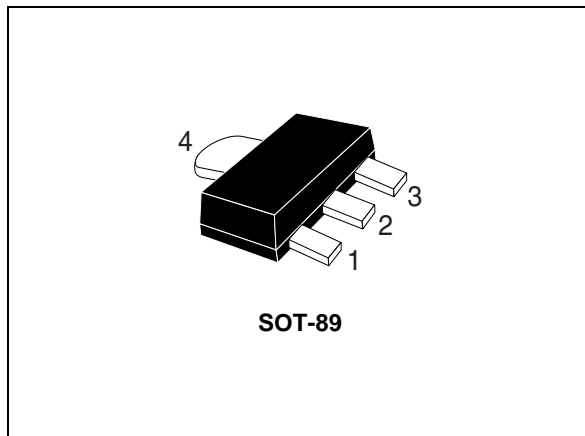
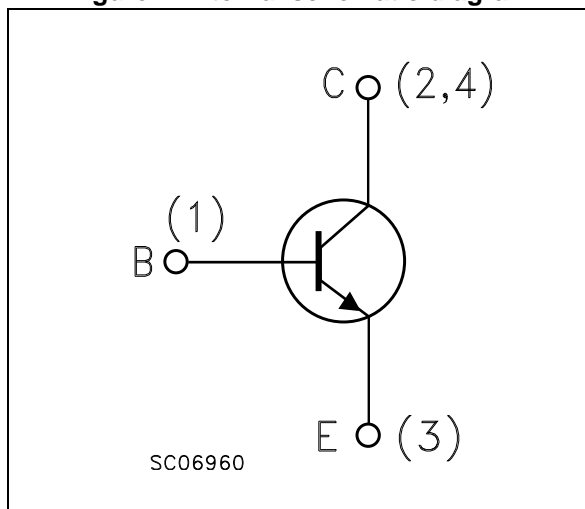

Figure 1. Internal schematic diagram



Features

- Very low collector-emitter saturation voltage
- High current gain characteristic
- Fast switching speed

Applications

- Power management
- DC-DC converters
- Automotive

Description

This device is a NPN transistor manufactured using new low voltage planar technology with double metal process. The result is a transistor which boasts exceptionally high gain performance coupled with very low saturation voltage.

Table 1. Device summary

Order codes	Marking	Package	Packaging
3STF1640	1640	SOT-89	Tape and reel

Contents

1	Electrical ratings	3
2	Electrical characteristics	4
	2.1 Test circuits	5
3	Package mechanical data	6
4	Packaging mechanical data	9
5	Revision history	11

1 Electrical ratings

Table 2. Absolute maximum ratings

Symbol	Parameter	Value	Unit
V_{CES}	Collector-emitter voltage ($V_{BE} = 0$)	40	V
V_{CEO}	Collector-emitter voltage ($I_B = 0$)	40	V
V_{EBO}	Emitter-base voltage ($I_C = 0$)	7	V
I_C	Collector current	6	A
I_{CM}	Collector peak current ($t_P < 1$ ms)	20	A
P_{tot}	Total dissipation at $T_{amb} = 25$ °C	1.5	W
T_{stg}	Storage temperature	-65 to 150	°C
T_J	Max. operating junction temperature	150	°C

Table 3. Thermal data

Symbol	Parameter	Value	Unit
$R_{thJA}^{(1)}$	Thermal resistance junction-ambient max	83	°C/W

1. Device mounted on PCB area of 1 cm²

2 Electrical characteristics

$T_{\text{case}} = 25\text{ °C}$ unless otherwise specified.

Table 4. Electrical characteristics

Symbol	Parameter	Test conditions	Min.	Typ.	Max.	Unit
I_{CBO}	Collector cut-off current ($I_{\text{E}} = 0$)	$V_{\text{CB}} = 40\text{ V}$			0.1	μA
I_{EBO}	Emitter cut-off current ($I_{\text{C}} = 0$)	$V_{\text{EB}} = 5\text{ V}$			0.1	μA
$V_{(\text{BR})\text{CBO}}$	Collector-base breakdown voltage ($I_{\text{E}} = 0$)	$I_{\text{C}} = 100\text{ }\mu\text{A}$	40			V
$V_{(\text{BR})\text{CEO}}^{(1)}$	Collector-emitter breakdown voltage ($I_{\text{B}} = 0$)	$I_{\text{C}} = 10\text{ mA}$	40			V
$V_{(\text{BR})\text{EBO}}$	Emitter-base breakdown voltage ($I_{\text{C}} = 0$)	$I_{\text{E}} = 100\text{ }\mu\text{A}$	7			V
$V_{\text{CE}(\text{sat})}^{(1)}$	Collector-emitter saturation voltage	$I_{\text{C}} = 1\text{ A}, I_{\text{B}} = 20\text{ mA}$		50		mV
		$I_{\text{C}} = 1\text{ A}, I_{\text{B}} = 100\text{ mA}$		40		mV
		$I_{\text{C}} = 6\text{ A}, I_{\text{B}} = 300\text{ mA}$		170		mV
$V_{\text{BE}(\text{sat})}^{(1)}$	Base-emitter saturation voltage	$I_{\text{C}} = 6\text{ A}, I_{\text{B}} = 6\text{ mA}$			1.1	V
$h_{\text{FE}}^{(1)}$	DC current gain	$I_{\text{C}} = 1\text{ A}, V_{\text{CE}} = 1\text{ V}$		350		
		$I_{\text{C}} = 6\text{ A}, V_{\text{CE}} = 1\text{ V}$		100		
		$I_{\text{C}} = 20\text{ A}, V_{\text{CE}} = 1\text{ V}$		20		
f_{T}	Transition frequency	$I_{\text{C}} = 0.1\text{ A}$ $V_{\text{CE}} = 10\text{ V}$ $f = 100\text{ MHz}$		100		MHz
C_{CBO}	Collector-base capacitance ($I_{\text{E}} = 0$)	$f = 1\text{ MHz}$ $V_{\text{CB}} = 10\text{ V}$		30		pF
t_{on}	Resistive load Turn-on time	$I_{\text{C}} = 1.5\text{ A}$ $V_{\text{CC}} = 10\text{ V}$		TBD		ns
t_{off}	Turn-off time	$I_{\text{B}(\text{on})} = - I_{\text{B}(\text{off})} = 150\text{ mA}$ $V_{\text{BB}(\text{off})} = - 5\text{ V}$		TBD		ns

1. Pulse test: pulse duration $\leq 300\text{ }\mu\text{s}$, duty cycle $\leq 2\%$

2.1 Test circuits

Figure 2. Resistive load switching

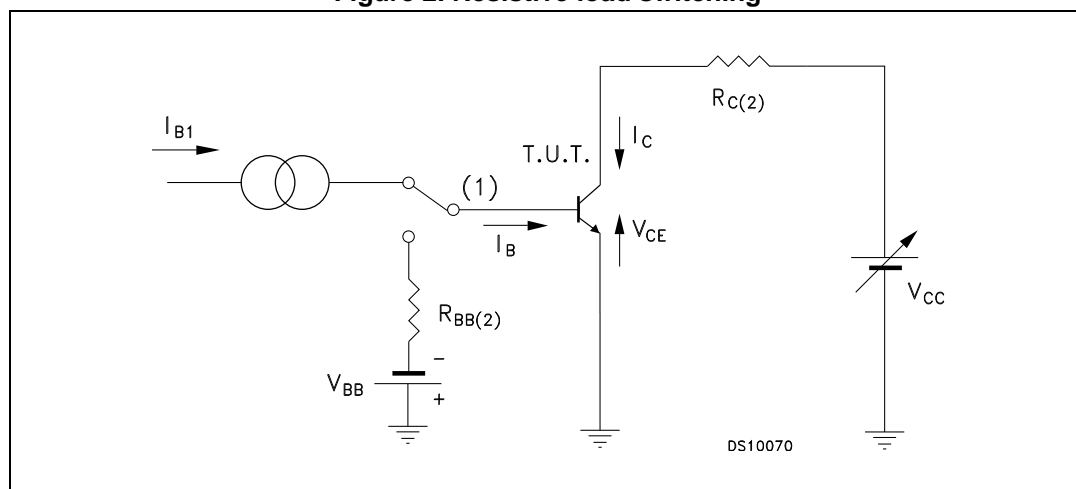

1. Fast electronic switch
2. Non-inductive resistor

3 Package mechanical data

In order to meet environmental requirements, ST offers these devices in different grades of ECOPACK[®] packages, depending on their level of environmental compliance. ECOPACK[®] specifications, grade definitions and product status are available at: www.st.com. ECOPACK[®] is an ST trademark.

Table 5. SOT-89 mechanical data

Dim.	mm		
	Min.	Typ.	Max.
A	1.40		1.60
B	0.44		0.56
B1	0.36		0.48
C	0.35		0.44
C1	0.35		0.44
D	4.40		4.60
D1	1.62		1.83
D3		0.90	
E	2.29		2.60
e	1.42		1.57
e1	2.92		3.07
H	3.94		4.25
H1	2.70		3.10
K	1°		8°
L	0.89		1.20
R		0.25	
β		90°	

Figure 3. SOT-89 drawings

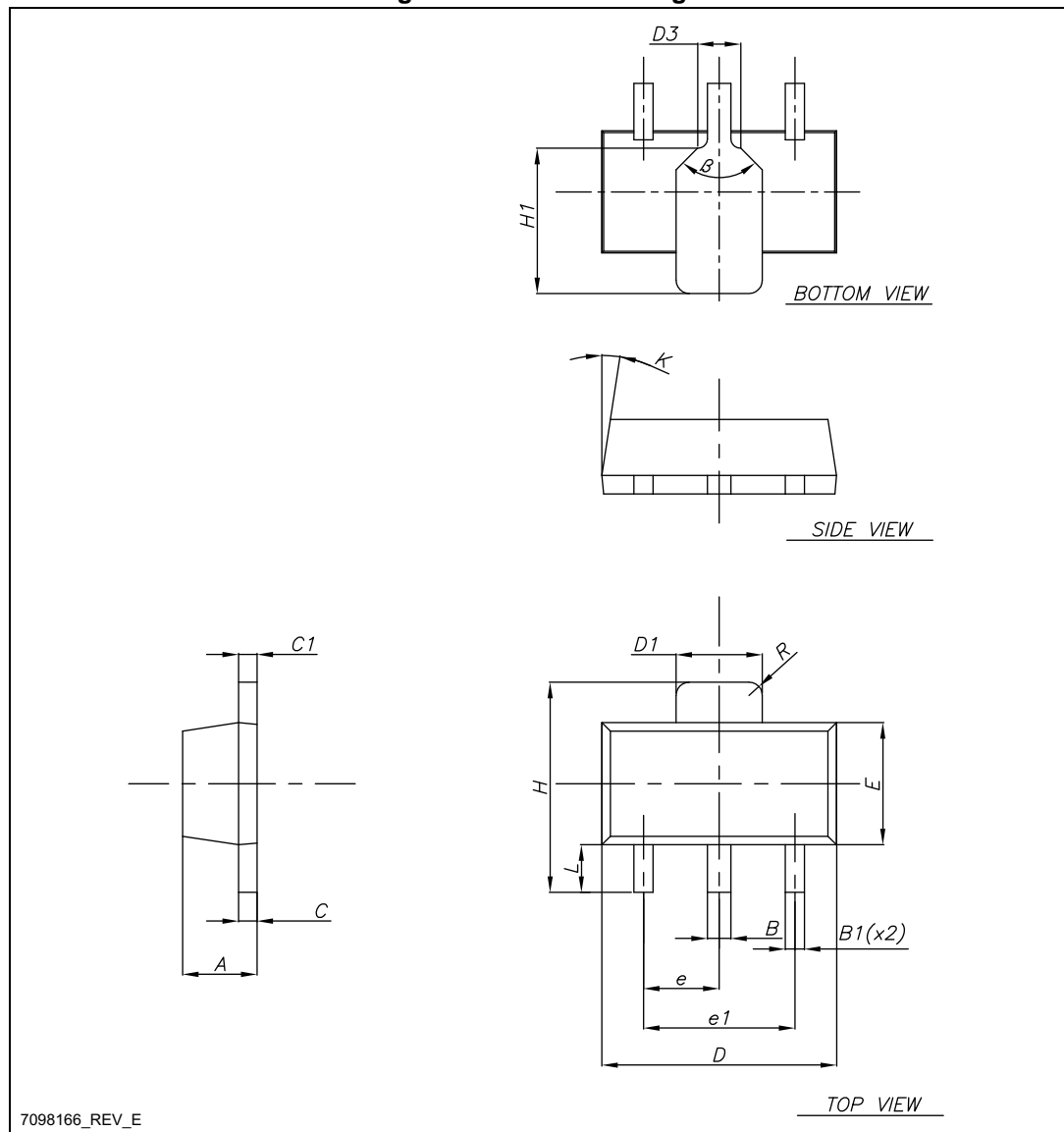
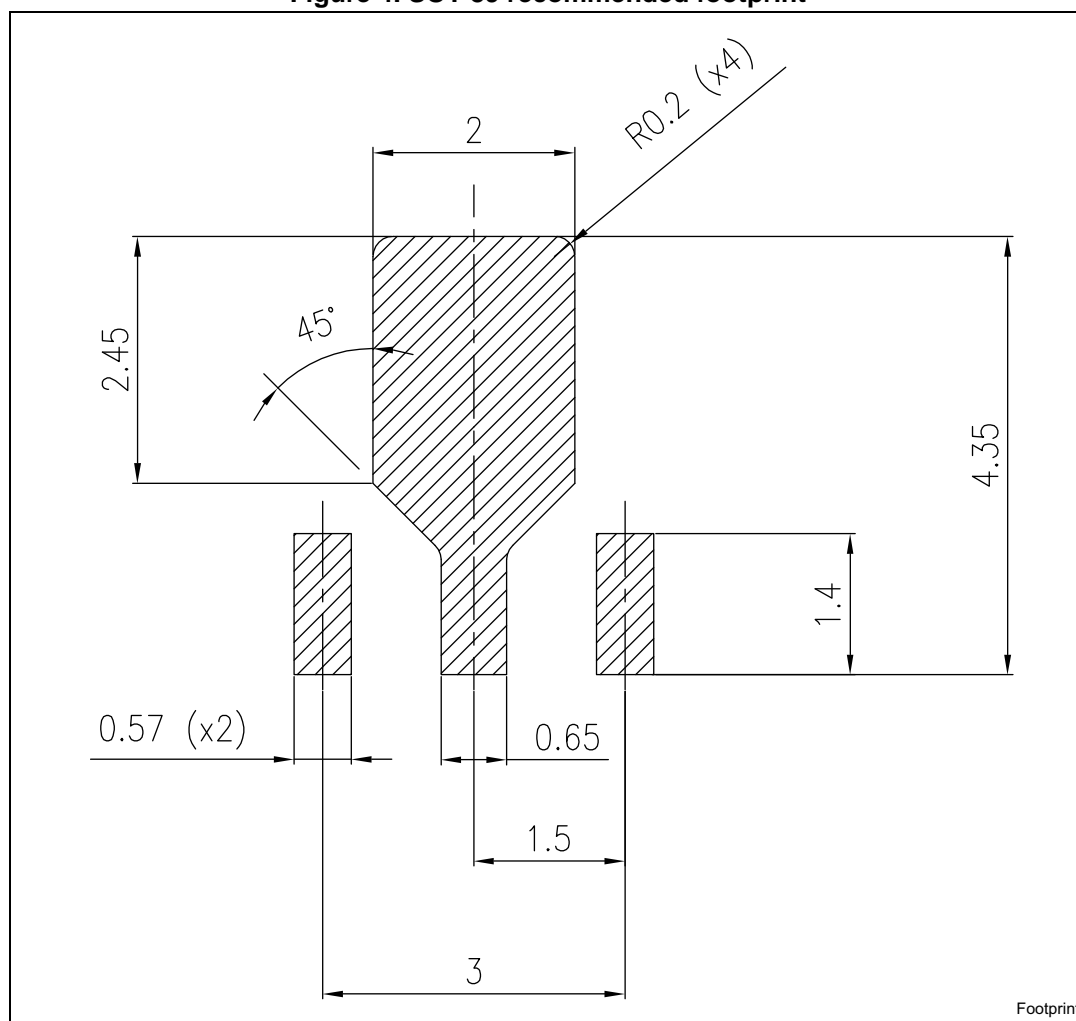

Figure 4. SOT-89 recommended footprint



4 Packaging mechanical data

Table 6. SOT-89 carrier tape dimensions

Dim.	mm.	
	Values	Tolerance
Ao	4.52	± 0.10
Bo	4.91	± 0.10
Ko	1.90	± 0.10
F	5.50	± 0.10
E	1.75	± 0.10
W	12	± 0.30
P2	2	± 0.10
Po	4	± 0.10
P1	8	± 0.10
T	0.30	± 0.10
D	∅ 1.55	± 0.05
D1	∅ 1.60	± 0.10

Figure 5. SOT-89 carrier tape drawing

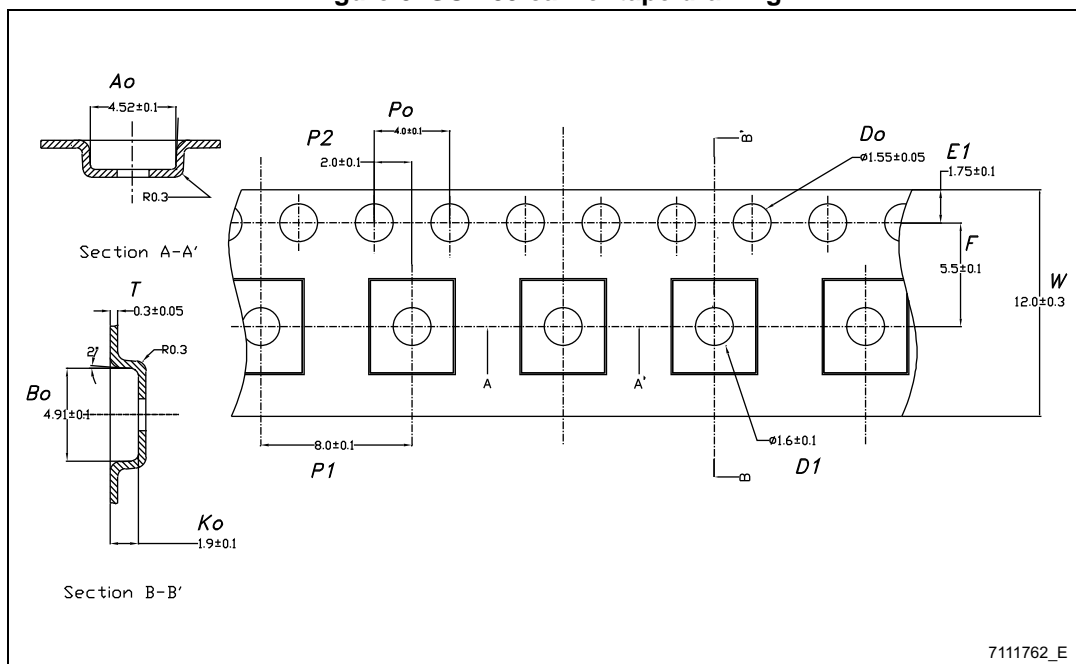
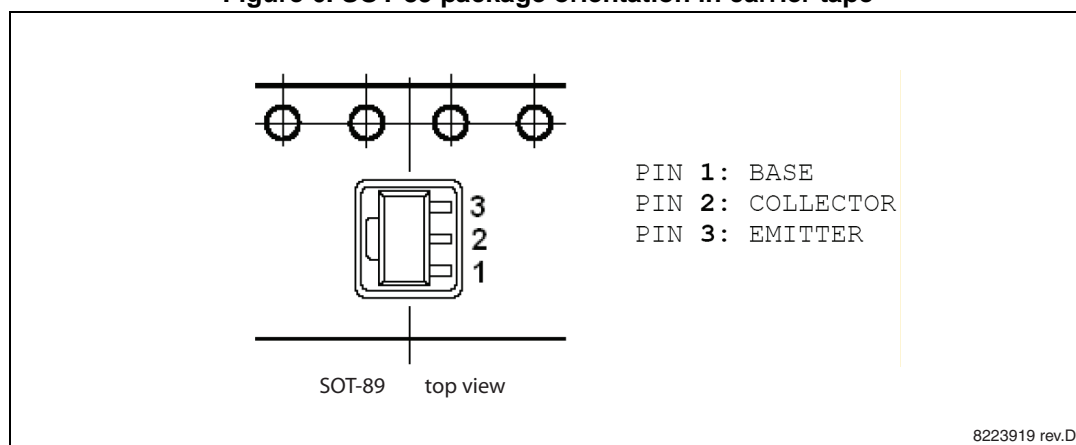

Figure 6. SOT-89 package orientation in carrier tape



5 Revision history

Table 7. Document revision history

Date	Revision	Changes
11-Sep-2012	1	Initial release.
31-Oct-2012	2	Updated title and description on the cover page. Document status promoted from target to preliminary data.
10-Apr-2013	3	<i>Applications</i> and <i>Description</i> have been modified in cover page.

Please Read Carefully:

Information in this document is provided solely in connection with ST products. STMicroelectronics NV and its subsidiaries ("ST") reserve the right to make changes, corrections, modifications or improvements, to this document, and the products and services described herein at any time, without notice.

All ST products are sold pursuant to ST's terms and conditions of sale.

Purchasers are solely responsible for the choice, selection and use of the ST products and services described herein, and ST assumes no liability whatsoever relating to the choice, selection or use of the ST products and services described herein.

No license, express or implied, by estoppel or otherwise, to any intellectual property rights is granted under this document. If any part of this document refers to any third party products or services it shall not be deemed a license grant by ST for the use of such third party products or services, or any intellectual property contained therein or considered as a warranty covering the use in any manner whatsoever of such third party products or services or any intellectual property contained therein.

UNLESS OTHERWISE SET FORTH IN ST'S TERMS AND CONDITIONS OF SALE ST DISCLAIMS ANY EXPRESS OR IMPLIED WARRANTY WITH RESPECT TO THE USE AND/OR SALE OF ST PRODUCTS INCLUDING WITHOUT LIMITATION IMPLIED WARRANTIES OF MERCHANTABILITY, FITNESS FOR A PARTICULAR PURPOSE (AND THEIR EQUIVALENTS UNDER THE LAWS OF ANY JURISDICTION), OR INFRINGEMENT OF ANY PATENT, COPYRIGHT OR OTHER INTELLECTUAL PROPERTY RIGHT.

ST PRODUCTS ARE NOT AUTHORIZED FOR USE IN WEAPONS. NOR ARE ST PRODUCTS DESIGNED OR AUTHORIZED FOR USE IN: (A) SAFETY CRITICAL APPLICATIONS SUCH AS LIFE SUPPORTING, ACTIVE IMPLANTED DEVICES OR SYSTEMS WITH PRODUCT FUNCTIONAL SAFETY REQUIREMENTS; (B) AERONAUTIC APPLICATIONS; (C) AUTOMOTIVE APPLICATIONS OR ENVIRONMENTS, AND/OR (D) AEROSPACE APPLICATIONS OR ENVIRONMENTS. WHERE ST PRODUCTS ARE NOT DESIGNED FOR SUCH USE, THE PURCHASER SHALL USE PRODUCTS AT PURCHASER'S SOLE RISK, EVEN IF ST HAS BEEN INFORMED IN WRITING OF SUCH USAGE, UNLESS A PRODUCT IS EXPRESSLY DESIGNATED BY ST AS BEING INTENDED FOR "AUTOMOTIVE, AUTOMOTIVE SAFETY OR MEDICAL" INDUSTRY DOMAINS ACCORDING TO ST PRODUCT DESIGN SPECIFICATIONS. PRODUCTS FORMALLY ESCC, QML OR JAN QUALIFIED ARE DEEMED SUITABLE FOR USE IN AEROSPACE BY THE CORRESPONDING GOVERNMENTAL AGENCY.

Resale of ST products with provisions different from the statements and/or technical features set forth in this document shall immediately void any warranty granted by ST for the ST product or service described herein and shall not create or extend in any manner whatsoever, any liability of ST.

ST and the ST logo are trademarks or registered trademarks of ST in various countries.

Information in this document supersedes and replaces all information previously supplied.

The ST logo is a registered trademark of STMicroelectronics. All other names are the property of their respective owners.

© 2013 STMicroelectronics - All rights reserved

STMicroelectronics group of companies

Australia - Belgium - Brazil - Canada - China - Czech Republic - Finland - France - Germany - Hong Kong - India - Israel - Italy - Japan - Malaysia - Malta - Morocco - Philippines - Singapore - Spain - Sweden - Switzerland - United Kingdom - United States of America

www.st.com



**Стандарт
Электрон
Связь**

Мы молодая и активно развивающаяся компания в области поставок электронных компонентов. Мы поставляем электронные компоненты отечественного и импортного производства напрямую от производителей и с крупнейших складов мира.

Благодаря сотрудничеству с мировыми поставщиками мы осуществляем комплексные и плановые поставки широчайшего спектра электронных компонентов.

Собственная эффективная логистика и склад в обеспечивает надежную поставку продукции в точно указанные сроки по всей России.

Мы осуществляем техническую поддержку нашим клиентам и предпродажную проверку качества продукции. На все поставляемые продукты мы предоставляем гарантию .

Осуществляем поставки продукции под контролем ВП МО РФ на предприятия военно-промышленного комплекса России , а также работаем в рамках 275 ФЗ с открытием отдельных счетов в уполномоченном банке. Система менеджмента качества компании соответствует требованиям ГОСТ ISO 9001.

Минимальные сроки поставки, гибкие цены, неограниченный ассортимент и индивидуальный подход к клиентам являются основой для выстраивания долгосрочного и эффективного сотрудничества с предприятиями радиоэлектронной промышленности, предприятиями ВПК и научно-исследовательскими институтами России.

С нами вы становитесь еще успешнее!

Наши контакты:

Телефон: +7 812 627 14 35

Электронная почта: sales@st-electron.ru

Адрес: 198099, Санкт-Петербург,
Промышленная ул, дом № 19, литера Н,
помещение 100-Н Офис 331