



Robust, reliable
analog solutions

MC33772 and MC33664 Battery Cell Controller and Transformer Physical Layer

The MC33772 battery six-cell controller and MC33664 transformer physical layer solutions enable reliable, safe and bill of materials (BOM) optimized Li-ion cell control applications with low-cost, robust, high-speed isolated communication.

TARGET APPLICATIONS

Automotive Applications

- ▶ High-voltage battery management systems (200 V–+800 V)
- ▶ 14 V Li-ion battery management systems

Industrial Applications

- ▶ Energy storage systems (ESS)
- ▶ Uninterrupted power supply (UPS)
- ▶ E-bikes, e-scooters

This solution addresses all existing battery management system topologies that support centralized, distributed daisy chain as well as high-speed and robust daisy chain. It is compatible with 14 V Li-ion batteries with one analog front end (AFE) and optional high-speed isolated or SPI communications. These fully integrated battery monitoring devices are for automotive and industrial mission-critical applications.

High-speed and robust daisy chain is used as an alternative to CAN solutions. Fast data acquisition and communication to the pack controller can be achieved in only 0.86 ms for the pack controller to acquire conversions from six cells, seven external temperatures, the current and coulomb counter. The MC33772 controller can work down to three cells and up to six cells. Also, determination of individual cell impedances in one shot is synchronized for cell voltages and current measurements at 113 μ s.

With functional verification and diagnostics, the MC33772 and MC33664 support ISO 26262 SafeAssure[®] functional safety. Functional verification of cell measure, current measure, cell terminal openings or leakage and ADC precision checks are all performed.

FEATURES

- ▶ 5.0 V (7.0 V for TPL) $< V_{PWR} < 30$ V operation, 42 V transient for TPL communication
- ▶ Isolated 2 Mbps differential communication or 4 Mbps SPI
- ▶ Up to six cell voltage (differential) measurements and stack voltage measurements
- ▶ Synchronized cell voltage/current measurement with coulomb counting
- ▶ Seven ADC/GPIO/temperature sensor inputs
- ▶ Addressable on initialization
- ▶ Onboard 300 mA passive cell balancing low ohmic MOSFETS with diagnostics
- ▶ Designed to support ISO 26262, up to ASIL D safety capability
- ▶ Low-power modes
- ▶ 48-pin LQFP package



EXAMPLE: TYPICAL 14 V BATTERY MANAGEMENT SYSTEM CHIPSET FOR SPI COMMUNICATION

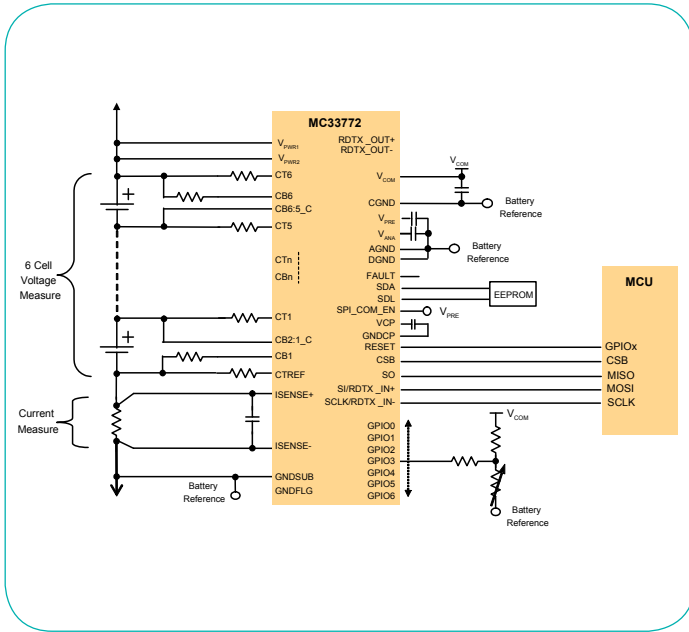

MC33772 AND MC33664 HIGH-VOLTAGE BATTERY MANAGEMENT SYSTEM FOR TPL COMMUNICATION

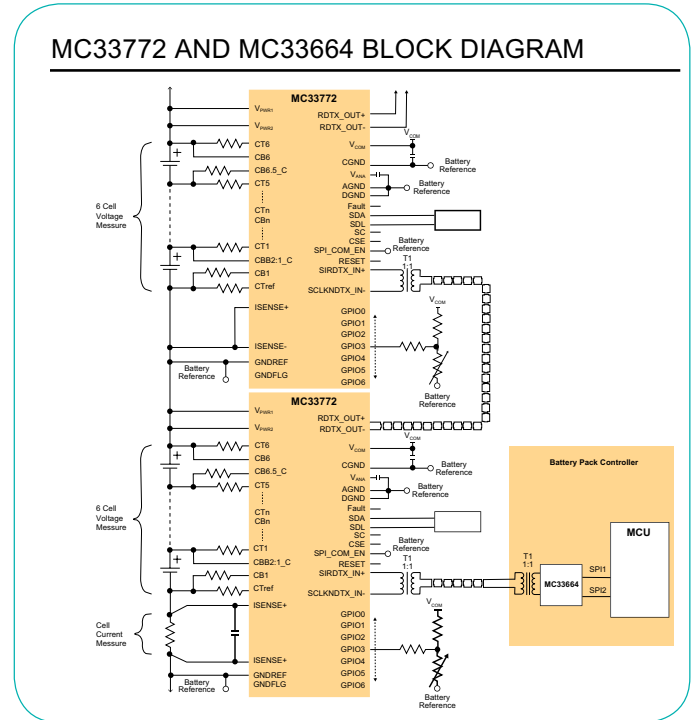

DEVELOPMENT TOOLS

Kit Number	Description
FRDM33772BSPIEVB (SPI mode)	MC33772 evaluation board
FRDM33772BTPLV (TPL mode)	MC33772 evaluation board
FRDM33664BEVB (TPL mode)	MC33664 evaluation board

MC33772 AND MC33664 PRODUCT DIFFERENTIATION

Features	Benefits
Integrated current channel and coulomb counting	Reduces BOM for 14 V Li-ion battery applications (only one AFE required)
Integrated current channel synchronized with cell voltage measurements	Determination of individual cell impedances in one shot for improved SoC/SoH prediction
Optional high-speed isolated or SPI communication	Addresses all existing battery management system topologies (centralized, distributed daisy chain, distributed CAN)
High-speed (2 Mbit/s) isolated high-speed differential communication	Allows BOM cost reduction by transition from CAN to daisy chain without compromise on communication speed
Fast data acquisition and communication to pack controller	Significant improvement of battery diagnostics
Hot plug and random cell connection robustness	No pre-damaging of cell and no damaging of devices during customer battery/electronics assembly
ESD/EMC robustness	ESD/EMC robustness avoids external components for robustness protection (BOM reduction, board space reduction)
Supports ISO 26262 SafeAssure® functional safety with single package solution	Has functional verification and diagnostics



PRODUCT LONGEVITY PROGRAM

These products are/ or may be supported by NXP®'s Product Longevity Program. For terms and conditions and to obtain a list of available products, visit www.nxp.com/ProductLongevity.

www.nxp.com/battery

NXP, the NXP logo and SafeAssure are trademarks of NXP B.V. All other product or service names are the property of their respective owners. © 2015–2018 NXP B.V.

Document Number: MC33772FSA4 REV 4





**Стандарт
Электрон
Связь**

Мы молодая и активно развивающаяся компания в области поставок электронных компонентов. Мы поставляем электронные компоненты отечественного и импортного производства напрямую от производителей и с крупнейших складов мира.

Благодаря сотрудничеству с мировыми поставщиками мы осуществляем комплексные и плановые поставки широчайшего спектра электронных компонентов.

Собственная эффективная логистика и склад в обеспечивает надежную поставку продукции в точно указанные сроки по всей России.

Мы осуществляем техническую поддержку нашим клиентам и предпродажную проверку качества продукции. На все поставляемые продукты мы предоставляем гарантию .

Осуществляем поставки продукции под контролем ВП МО РФ на предприятия военно-промышленного комплекса России , а также работаем в рамках 275 ФЗ с открытием отдельных счетов в уполномоченном банке. Система менеджмента качества компании соответствует требованиям ГОСТ ISO 9001.

Минимальные сроки поставки, гибкие цены, неограниченный ассортимент и индивидуальный подход к клиентам являются основой для выстраивания долгосрочного и эффективного сотрудничества с предприятиями радиоэлектронной промышленности, предприятиями ВПК и научно-исследовательскими институтами России.

С нами вы становитесь еще успешнее!

Наши контакты:

Телефон: +7 812 627 14 35

Электронная почта: sales@st-electron.ru

Адрес: 198099, Санкт-Петербург,
Промышленная ул, дом № 19, литера Н,
помещение 100-Н Офис 331