

PRODUCT NUMBER	DESCRIPTION	NOTES
10117949-XXXXLF	NON-HF	SEE SHT. 3
10117949-XXXXHLF	HALOGEN FREE (H)	SEE SHT. 3

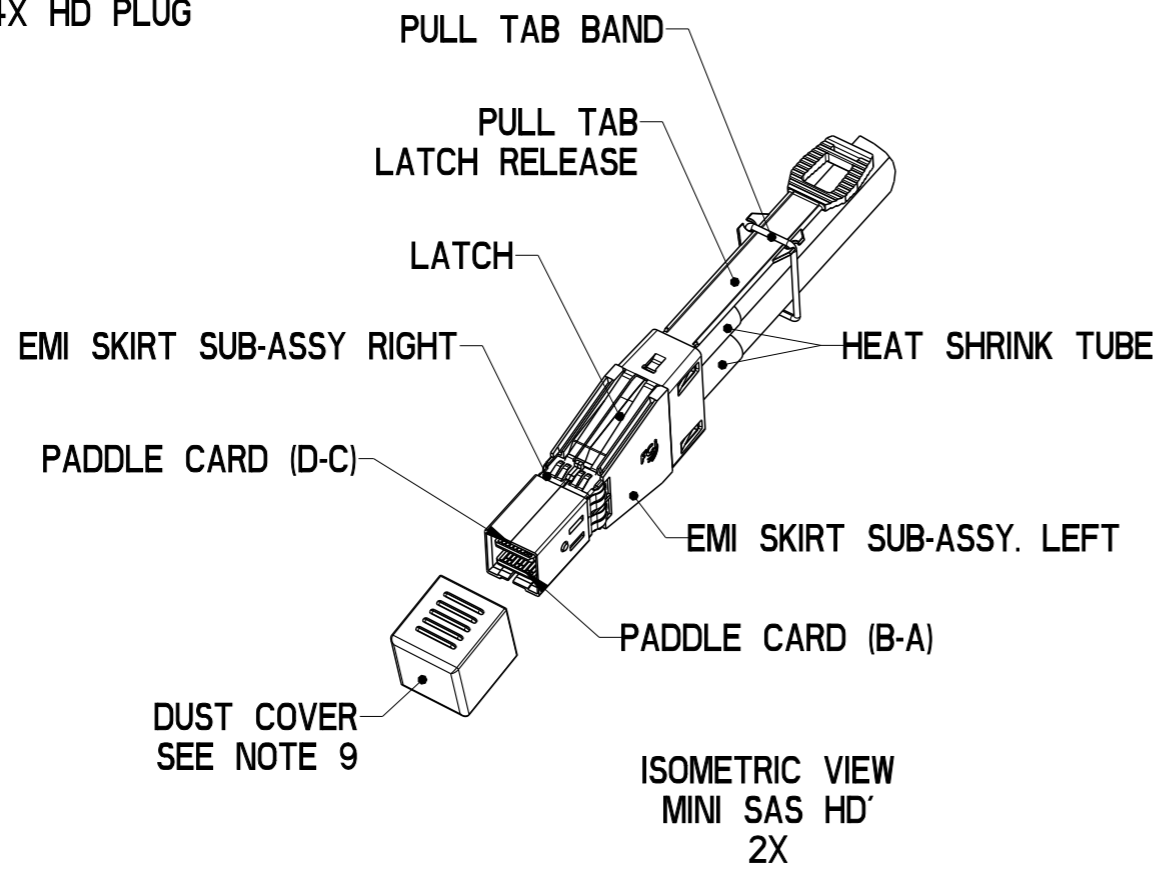

dr	David Lord	2011/09/06	projection	mm	size	A3	scale	1:2
eng	Tommy Lin	2013/05/21			ecn no		ELX-N-14803-1	
chr	-	-			rel level		Released	
appr	Roger Cheng	2013/05/21	product family		C&A		rel level	
			title FINAL ASSEMBLY (PASSIVE) MSAS HD 4X ASSEMBLY (12 Gb/s)			dwg no 10117949		rev G
www.fci.com			cat. no.		-		Product - Customer Drw	
			sheet 1 of 4					

PRODUCT NUMBER	DESCRIPTION	NOTES
10117949-XXXXLF	NON-HF	SEE SHT. 3
10117949-XXXXHLF	HALOGEN FREE (H)	SEE SHT. 3

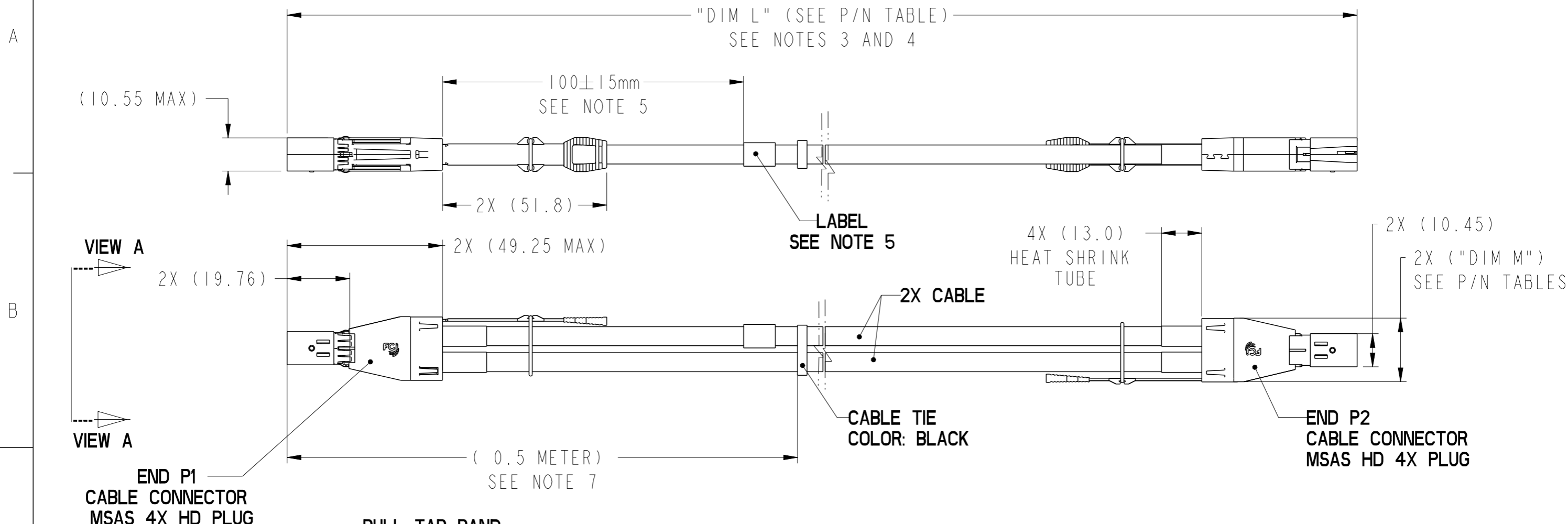
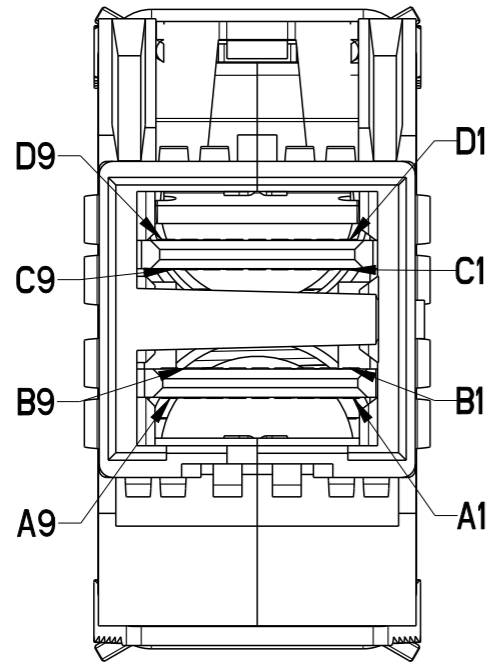

P1  
VIEW A  
SCALE 4:1

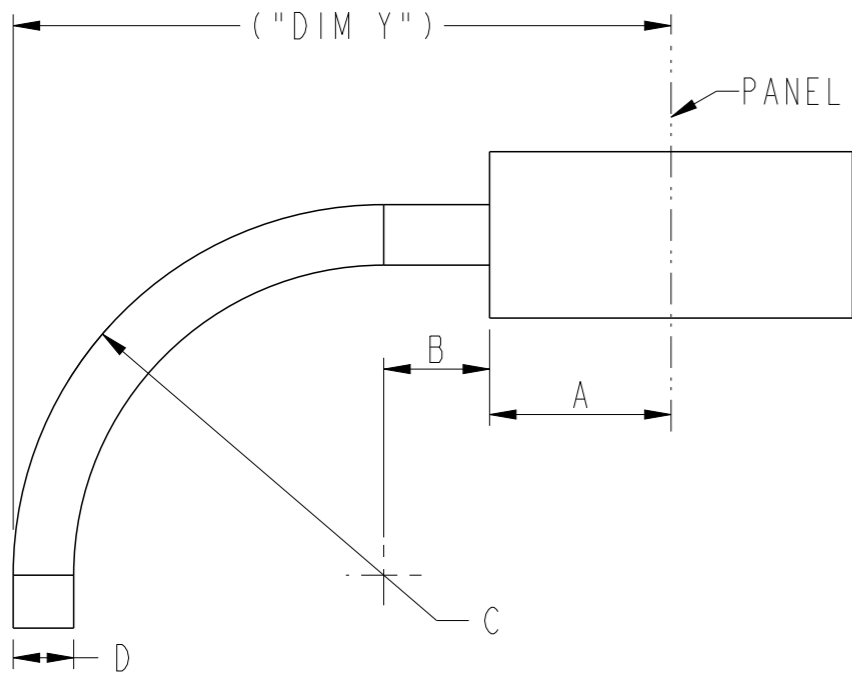

BEND RADIUS  
TOP VIEW OF CONNECTOR



MINIMUM CABLE BEND TABLE					
CABLE	A	B	C	D (nominal)	("DIM Y") NON-HF
24 AWG	29.5	13.0	50.28	∅8.38	92.78
26 AWG			42.6	∅7.1	85.1
28 AWG			36.6	∅6.1	79.1
30 AWG			31.8	∅5.3	74.3

MINIMUM CABLE BEND TABLE					
CABLE	A	B	C	D (nominal)	("DIM Y") HF
24 AWG	29.5	13.0	50.28	∅8.38	92.78
26 AWG			45	∅7.5	87.5
28 AWG			39	∅6.5	81.5
30 AWG			35.4	∅5.9	77.9

WIRING LIST (SEE NOTE 6)					
END P1			END P2		
POSITION	SYMBOL		POSITION	SYMBOL	
D9	GROUND	-----	B9	GROUND	-----
D8	Tx2-	○-----▷	B8	Rx2-	◁-----○
D7	Tx2+	○-----▷	B7	Rx2+	◁-----○
D6	GROUND	-----	B6	GROUND	-----
D5	Tx0-	○-----▷	B5	Rx0-	◁-----○
D4	Tx0+	○-----▷	B4	Rx0+	◁-----○
D3	GROUND	-----	B3	GROUND	-----
D2	Vman	◁-----▷	B2	ModPrsL	◁-----▷
D1	Vact	◁-----▷	B1	Vact	◁-----▷
C1	SCL	◁-----▷	A1	Reserved	◁-----▷
C2	SDA	◁-----▷	A2	IntI	◁-----▷
C3	GROUND	-----	A3	GROUND	-----
C4	Tx1+	○-----▷	A4	Rx1+	◁-----○
C5	Tx1-	○-----▷	A5	Rx1-	◁-----○
C6	GROUND	-----	A6	GROUND	-----
C7	Tx3+	○-----▷	A7	Rx3+	◁-----○
C8	Tx3-	○-----▷	A8	Rx3-	◁-----○
C9	GROUND	-----	A9	GROUND	-----
B9	GROUND	-----	D9	GROUND	-----
B8	Rx2-	◁-----○	D8	Tx2-	○-----▷
B7	Rx2+	◁-----○	D7	Tx2+	○-----▷
B6	GROUND	-----	D6	GROUND	-----
B5	Rx0-	◁-----○	D5	Tx0-	○-----▷
B4	Rx0+	◁-----○	D4	Tx0+	○-----▷
B3	GROUND	-----	D3	GROUND	-----
B2	ModPrsL	◁-----▷	D2	Vman	◁-----▷
B1	Vact	◁-----▷	D1	Vact	◁-----▷
A1	Reserved	◁-----▷	C1	SCL	◁-----▷
A2	IntL	◁-----▷	C2	SDA	◁-----▷
A3	GROUND	-----	C3	GROUND	-----
A4	Rx1+	◁-----○	C4	Tx1+	○-----▷
A5	Rx1-	◁-----○	C5	Tx1-	○-----▷
A6	GROUND	-----	C6	GROUND	-----
A7	Rx3+	◁-----○	C7	Tx3+	○-----▷
A8	Rx3-	◁-----○	C8	Tx3-	○-----▷
A9	GROUND	-----	C9	GROUND	-----

SHIELD-----▷ SHIELD

dr	David Lord	2011/09/06	projection	mm	size	A3	scale	1:2
eng	Tommy Lin	2013/05/21			ecn no	ELX-N-14803-1	rel level	Released
chr	-	-						
appr	Roger Cheng	2013/05/21	product family	C&A	rev no	10117949	cat. no.	-
			FINAL ASSEMBLY (PASSIVE)					
www.fci.com			MSAS HD 4X ASSEMBLY (12 Gb/s)			sheet 2 of 4		

PART NUMBER (NON-HALOGEN FREE) SEE NOTE 12	"DIM L" LENGTH (Meters)	"DIM M" (mm)	AWG
10117949-2003LF	0.3	17.3	30
10117949-2005LF	0.5	17.3	30
10117949-2008LF	0.75	17.3	30
10117949-2010LF	1.0	17.3	30
10117949-2015LF	1.5	17.3	30
10117949-2020LF	2.0	17.3	30
10117949-3010LF	1.0	17.3	28
10117949-3015LF	1.5	17.3	28
10117949-3020LF	2.0	17.3	28
10117949-3025LF	2.5	17.3	28
10117949-3030LF	3.0	17.3	28
10117949-4010LF	1.0	20.1	26
10117949-4020LF	2.0	20.1	26
10117949-4025LF	2.5	20.1	26
10117949-4030LF	3.0	20.1	26
10117949-4035LF	3.5	20.1	26
10117949-4040LF	4.0	20.1	26
10117949-4050LF	5.0	20.1	26
10117949-4060LF	6.0	20.1	26
10117949-5060LF	6.0	20.1	24
10117949-5070LF	7.0	20.1	24
10117949-5080LF	8.0	20.1	24

PART NUMBER (HALOGEN FREE) SEE NOTE 11	"DIM L" LENGTH (Meters)	"DIM M" (mm)	AWG
10117949-2003HLF	0.3	17.3	30
10117949-2005HLF	0.5	17.3	30
10117949-2008HLF	0.75	17.3	30
10117949-2010HLF	1.0	17.3	30
10117949-2015HLF	1.5	17.3	30
10117949-2020HLF	2.0	17.3	30
10117949-3010HLF	1.0	17.3	28
10117949-3015HLF	1.5	17.3	28
10117949-3020HLF	2.0	17.3	28
10117949-3025HLF	2.5	17.3	28
10117949-3030HLF	3.0	17.3	28
10117949-4010HLF	1.0	20.1	26
10117949-4020HLF	2.0	20.1	26
10117949-4025HLF	2.5	20.1	26
10117949-4030HLF	3.0	20.1	26
10117949-4035HLF	3.5	20.1	26
10117949-4040HLF	4.0	20.1	26
10117949-4050HLF	5.0	20.1	26
10117949-4060HLF	6.0	20.1	26
10117949-5060HLF	6.0	20.1	24
10117949-5070HLF	7.0	20.1	24
10117949-5080HLF	8.0	20.1	24



Copyright FCI.

dr	David Lord	2011/09/06			size	A3	scale	1:2
eng	Tommy Lin	2013/05/21			ecn no	ELX-N-14803-1		
chr	-	-			rel level	Released		
appr	Roger Cheng	2013/05/21	product family	C&A		rev	G	
		FINAL ASSEMBLY (PASSIVE) MSAS HD 4X ASSEMBLY (12 Gb/s)			dwg no 10117949	www.fci.com		
cat. no.		-		Product - Customer Drw		sheet 3 of 4		

PRODUCT NUMBER	DESCRIPTION	NOTES
10117949-XXXXLF	NON-HF	SEE SHT. 3
10117949-XXXXHLF	HALOGEN FREE (H)	SEE SHT. 3

NOTES:

- MATERIAL:  
 BACK SHELLS: ZINC ALLOY/ COPPER UNDERPLATE/ NICKEL OVERPLATE  
 PULL TAB: THERMOPLASTIC POLYMER  
 LATCH : STAINLESS STEEL  
 FERRULE: BRASS  
 EMI SKIRT: STAINLESS STEEL  
 LOCTITE  
 PADDLE CARD: PRINTED CIRCUIT SUBSTRATE  
 HEAT SHRINK TUBE: POLYOLEFIN
- THIS PRODUCT MEETS THE RESTRICTION OF HAZARDOUS SUBSTANCES IN ELECTRICAL AND ELECTRONIC EQUIPMENT (RoHS) DIRECTIVE (2002/95/EC)
- THIS DIMENSION IS A FINISHED PRODUCT LENGTH.
- UNLESS OTHERWISE SPECIFIED ASSEMBLED LENGTH TOLERANCE IS TO BE:  
 "DIM L" < 1 METER = ±25mm  
 "DIM L" 1 METER TO 4 METERS = ± 2% OF "DIM L"  
 "DIM L" > 4 METERS = +0.00/-4% OF "DIM L"

- LABEL DETAILS:  

MANUFACTURER CODE OR NAME	COUNTRY OF ORIGIN
CUSTOMER P/N OR FCI P/N	
REVISION	
SERIAL NUMBER	

FONT SHALL BE CLEARLY VISIBLE AND BLACK IN COLOR.  
 SERIAL NUMBER IS ONLY USED FOR TRACKING PRODUCT,DETAIL IS AS BELOW :

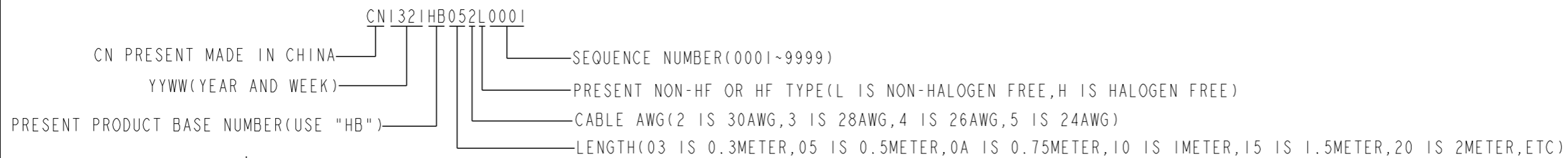

LABEL EXAMPLE ↓

FCI	CHINA
10117949-2005LF	
REV.G	
CN1321HB052L0001	

- ALL CABLE ASSEMBLIES 100% TESTED FOR CONTINUITY AS DEFINED IN WIRING LIST.
- PLACE A CABLE TIE EVERY 0.5 METER ON ALL ASSEMBLIES, UNLESS OTHERWISE SPECIFIED. IN CASE OF 0.5 METER CABLE ASSEMBLY, CABLE TIE IS TO BE APPLIED AT THE MIDWAY POINT.
- OTHER TESTING PERFORMED AS REQUIRED BY PRODUCT SPECIFICATION: GS-12-651.
- PACKAGING OF LEAD FREE PRODUCTS MEETS LABELING AND PACKAGING PER SPECIFICATION GS-14-920. PACKAGE CABLE ASSEMBLIES PER GS-14-1272. DUST COVERS ARE TO BE ASSEMBLED PRIOR TO PACKAGING. FCI PACKAGE TRACKING BAG LABEL IS ONLY FOR REFERENCE.

NOTES CONTINUED:

- A "△" SYMBOL WILL BE NEXT TO ANY DIMENSION, VIEW, OR NOTE WHICH HAS BEEN MODIFIED WITH THE CURRENT DRAWING REVISION. THE CURRENT REVISION WILL BE SHOWN IN THE SYMBOL.
- "H" PRODUCT NUMBERS DESIGNATE THE USE OF HALOGEN FREE RAW CABLE.
- HALOGEN FREE RAW CABLE CAN BE USED AS A SUBSTITUTE ON NON-HF PRODUCT NUMBERS.
- CABLE ASSEMBLY CAN MEET SAS 3.0 SPECIFICATION.
- MATES TO SERIES: 10112626 or 10112627 Or 10112628

dr	David Lord	2011/09/06	projection	mm	size	A3	scale	1:2
eng	Tommy Lin	2013/05/21			ecn no ELX-N-14803-1			
chr	-	-			product family C&A		rel level Released	
appr	Roger Cheng	2013/05/21			title FINAL ASSEMBLY (PASSIVE) MSAS HD 4X ASSEMBLY (12 Gb/s)		dwg no 10117949	rev G
www.fci.com			cat. no. -		Product - Customer Drw			sheet 4 of 4

Copyright FCI.



## Стандарт Электрон Связь

Мы молодая и активно развивающаяся компания в области поставок электронных компонентов. Мы поставляем электронные компоненты отечественного и импортного производства напрямую от производителей и с крупнейших складов мира.

Благодаря сотрудничеству с мировыми поставщиками мы осуществляем комплексные и плановые поставки широчайшего спектра электронных компонентов.

Собственная эффективная логистика и склад в обеспечивает надежную поставку продукции в точно указанные сроки по всей России.

Мы осуществляем техническую поддержку нашим клиентам и предпродажную проверку качества продукции. На все поставляемые продукты мы предоставляем гарантию .

Осуществляем поставки продукции под контролем ВП МО РФ на предприятия военно-промышленного комплекса России , а также работаем в рамках 275 ФЗ с открытием отдельных счетов в уполномоченном банке. Система менеджмента качества компании соответствует требованиям ГОСТ ISO 9001.

Минимальные сроки поставки, гибкие цены, неограниченный ассортимент и индивидуальный подход к клиентам являются основой для выстраивания долгосрочного и эффективного сотрудничества с предприятиями радиоэлектронной промышленности, предприятиями ВПК и научно-исследовательскими институтами России.

С нами вы становитесь еще успешнее!

### Наши контакты:

**Телефон:** +7 812 627 14 35

**Электронная почта:** [sales@st-electron.ru](mailto:sales@st-electron.ru)

**Адрес:** 198099, Санкт-Петербург,  
Промышленная ул, дом № 19, литера Н,  
помещение 100-Н Офис 331