



MAX1556 Evaluation Kit

General Description

The MAX1556 evaluation kit (EV kit) is a fully assembled and tested circuit board that evaluates the MAX1556 and MAX1557 PWM step-down DC-DC converters. The circuit operates from 2.6V to 5.5V. The MAX1556 delivers up to 1.2A and has pin-selectable 1.8V, 2.5V, 3.3V, and adjustable output. The MAX1557 delivers up to 600mA and has pin-selectable 1V, 1.3V, 1.5V, and adjustable output. Each circuit features an on-board shutdown control.

Component List

DESIGNATION	QTY	DESCRIPTION
C1, C6	2	10 μ F \pm 10%, 6.3V X5R ceramic capacitors (0805) Murata GRM21BR60J106K or equivalent
C2, C7	2	22 μ F \pm 10%, 6.3V X5R ceramic capacitors (1206) Murata GRM31CR60J226K or equivalent
C3, C8	0	Not installed, capacitors (0805)
C4, C9	2	0.001 μ F \pm 10%, 50V X7R ceramic capacitors (0402) Murata GRP155R71H102K or equivalent
C5, C10	0	Not installed, capacitors (0603)
C11	1	0.47 μ F \pm 10%, 6.3V X5R ceramic capacitor (0402) Murata GRM155R60J474K or equivalent
JU1–JU6	6	3-pin headers
L1	1	3.3 μ H inductor, 0.036 Ω , 1.3A, 5.0mm x 5.0mm x 2.0mm Taiyo Yuden LMNP04SB3R3N
L2	1	4.7 μ H inductor, 0.05 Ω , 1.2A, 5.0mm x 5.0mm x 2.0mm Taiyo Yuden LMNP04SB4R7N
R1, R3	0	Shorted on PC board, resistors (0603)
R2, R4	0	Not installed, resistors (0603)
R5	1	100 Ω \pm 1% resistor (0402)
U1	1	MAX1556ETB
U2	1	MAX1557ETB
None	6	Shunts, position 2
None	1	MAX1556 EV kit PC board

Features

- ◆ Up to 97% Efficiency
- ◆ 95% Efficiency at 1mA Load Current
- ◆ 1MHz PWM Switching Frequency
- ◆ Tiny Inductors
- ◆ Pin-Selectable Output Voltages
MAX1556: 3.3V, 2.5V, 1.8V, and Adjustable
MAX1557: 1.5V, 1.3V, 1.0V, and Adjustable
- ◆ 1.2A Guaranteed Output Current (MAX1556)
- ◆ Voltage Positioning Optimizes Load-Transient Response
- ◆ Low 16 μ A Quiescent Current
- ◆ Low 27 μ A Quiescent Current in Dropout
- ◆ Low 0.1 μ A Shutdown Current
- ◆ Analog Soft-Start with Zero Overshoot Current
- ◆ Small, 10-Pin, 3mm x 3mm TDFN Package
- ◆ Fully Assembled and Tested

Ordering Information

PART	TEMP RANGE	IC PACKAGE
MAX1556EVKIT	0°C to +70°C	10 TDFN-EP*

*EP = Exposed paddle.

Component Suppliers

SUPPLIER	PHONE	WEBSITE
Murata	814-237-1431	www.murata.com
Taiyo Yuden	408-573-4150	www.t-yuden.com
Vishay	402-563-6866	www.vishay.com

Note: Indicate that you are using the MAX1556 when contacting these component suppliers.

Quick Start

Recommended Equipment

- One variable DC power supply capable of supplying up to 5.5V at 1.2A
- One voltmeter (DMM)

MAX1556 Evaluation Kit

Procedure (MAX1556ETB)

The MAX1556 EV kit is fully assembled and tested. Follow the steps below to verify board operation:

- 1) Select the desired output voltage with JU1, JU2, and JU3 (see Table 1). The EV kit is preset to a 1.8V output.
- 2) Connect the positive terminal of the voltmeter to the pad labeled OUT. Connect the ground terminal of the voltmeter to the pad labeled GND nearest the OUT pad. Connect a load from OUT to the GND pad closest to OUT.
- 3) Preset the power supply to between 2.6V and 5.5V, and turn the power supply off. **Do not turn on the power supply until all connections are completed.**
- 4) Connect the positive power-supply terminal to the pad labeled IN. Connect the power-supply ground to the pad labeled GND nearest the IN pad.
- 5) Turn on the power supply and verify the output voltage is the desired voltage from setting JU1, JU2, and JU3 (default is 1.8V).

Procedure (MAX1557ETB)

The MAX1556 EV kit is fully assembled and tested. Follow the steps below to verify board operation:

- 1) Select the desired output voltage with JU4, JU5, and JU6 (see Table 2). The EV kit is preset to a 1.0V output.
- 2) Connect the positive terminal of the voltmeter to the pad labeled OUT2. Connect the ground terminal of the voltmeter to the pad labeled GND2 nearest the OUT2 pad. Connect a load from OUT2 to the GND2 pad closest to OUT2.
- 3) Preset the power supply to between 2.6V and 5.5V, and turn the power supply off. **Do not turn on the power supply until all connections are completed.**
- 4) Connect the positive power-supply terminal to the pad labeled IN2. Connect the power-supply ground to the pad labeled GND2 nearest the IN2 pad.

- 5) Turn on the power supply and verify the output voltage is the desired voltage from setting JU4, JU5, and JU6 (default is 1.0V).

Detailed Description

The MAX1556 EV kit contains two separate PWM step-down DC-DC converter circuits. Either circuit can be powered from a DC power supply with a 2.6V to 5.5V input range. The top and bottom circuit are separate from each other and do not share a common ground plane.

The top circuit (MAX1556) provides pin-selectable output voltages of 3.3V, 2.5V, 1.8V, and adjustable at 1.2A.

The bottom circuit (MAX1557) provides pin-selectable output voltages of 1.5V, 1.3V, 1.0V, and adjustable at 600mA.

Pin-Selectable Output Voltages

The MAX1556 output voltage is selected with JU1 and JU2, as shown in Table 1.

The MAX1557 output voltage is selected with JU4 and JU5, as shown in Table 2.

Evaluating Other Output Voltages

The MAX1556 EV kit comes with the MAX1556 preset to a 1.8V output and the MAX1557 preset to a 1V output. To evaluate other voltages besides the preset values, set the MAX1556 (or MAX1557) to adjustable mode. The footprints for the feedback resistors are available on the backside of the evaluation kit. Refer to the *Adjusting the Output Voltage* section in the MAX1556 data sheet for a detailed description on calculating these feedback resistor values for the desired output voltage. Resistor R1 for the MAX1556 circuit (R3 on MAX1557) is shorted on the evaluation kit. This short must be cut prior to the placement of a resistor on the footprint. Resistor R2 for the MAX1556 circuit (R4 for MAX1557) is open and requires no modification before placing a resistor on the footprint.

Table 1. Output Voltage Selection (MAX1556ETB)

JU1	JU2	JU3	MAX1556 V _{OUT}
1 and 2	1 and 2	1 and 2	1.8V
1 and 2	2 and 3	1 and 2	2.5V
2 and 3	1 and 2	1 and 2	3.3V
2 and 3	2 and 3	1 and 2	ADJ
—	—	2 and 3	Shutdown

Note: Default configuration is JU1, JU2, and JU3 (1 and 2).

MAX1556 Evaluation Kit

Evaluates: MAX1556/MAX1557

Table 2. Output Voltage Selection (MAX1557ETB)

JU4	JU5	JU6	MAX1557 V _{OUT}
1 and 2	1 and 2	1 and 2	1.0V
1 and 2	2 and 3	1 and 2	1.3V
2 and 3	1 and 2	1 and 2	1.5V
2 and 3	2 and 3	1 and 2	ADJ
—	—	2 and 3	Shutdown

Note: Default configuration is JU4, JU5, and JU6 (1 and 2).

External Shutdown Control

The MAX1556 EV kit comes preset with $\overline{\text{SHDN}}$ and $\overline{\text{SHDN2}}$ pulled high so that the MAX1556 and MAX1557 are enabled when the input voltage is applied. To operate the shutdown control from an external signal, remove the

shunt on JU3 for the MAX1556 (JU6 for the MAX1557). Apply a logic high to SHDN to enable the MAX1556, or apply a logic low to shut down the MAX1556. Apply a logic high to SHDN2 to enable the MAX1557, or apply a logic low to shut down the MAX1557.

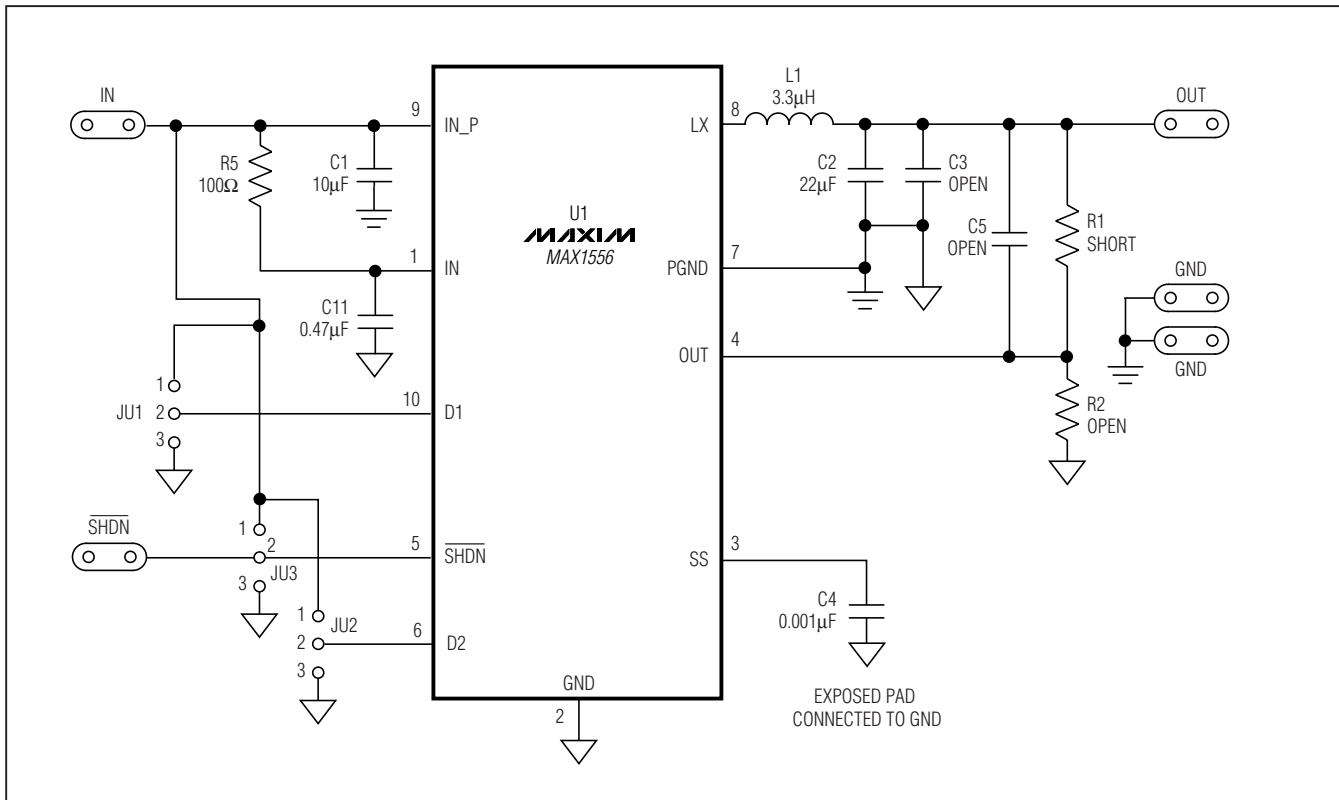

Figure 1a. MAX1556 EV Kit Schematic (MAX1556)

MAX1556 Evaluation Kit

Evaluates: MAX1556/MAX1557

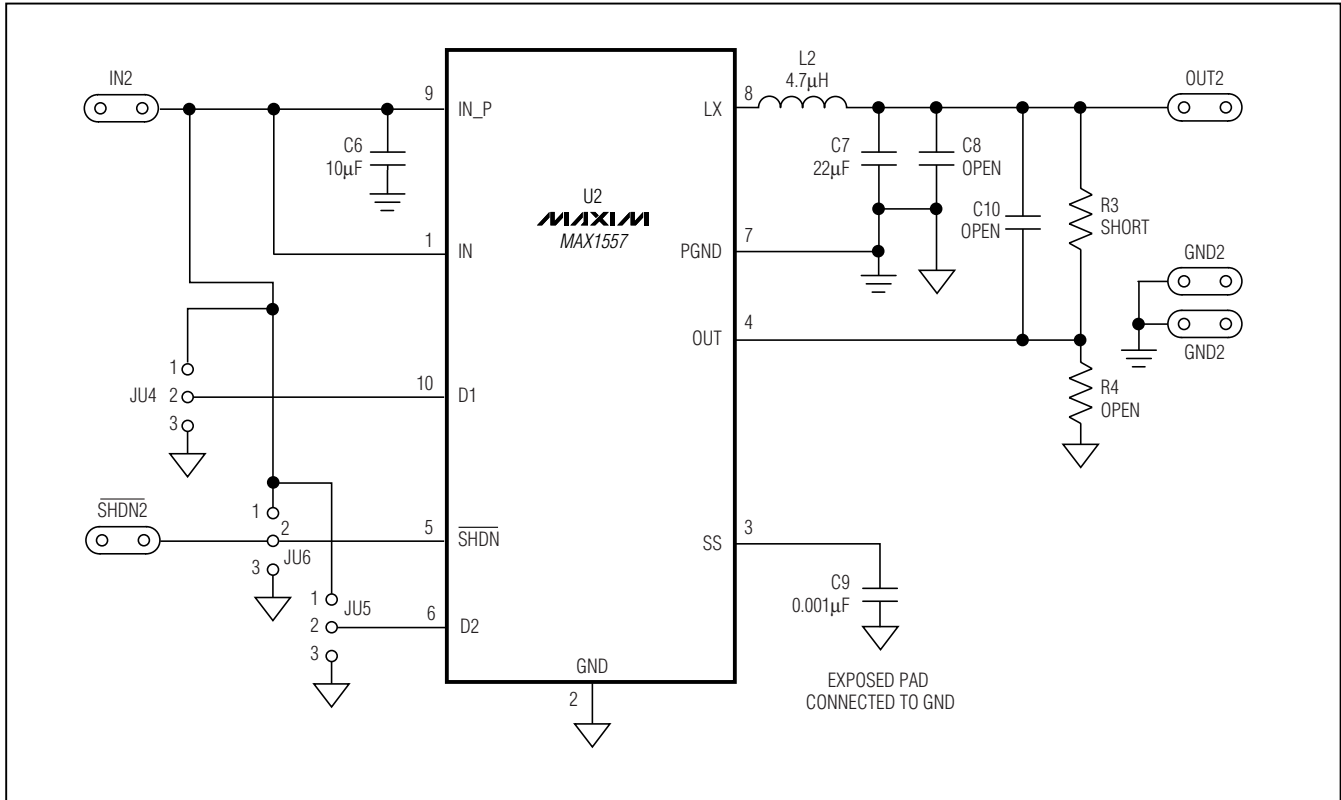

Figure 1b. MAX1556 EV Kit Schematic (MAX1557)

MAX1556 Evaluation Kit

Evaluates: MAX1556/MAX1557

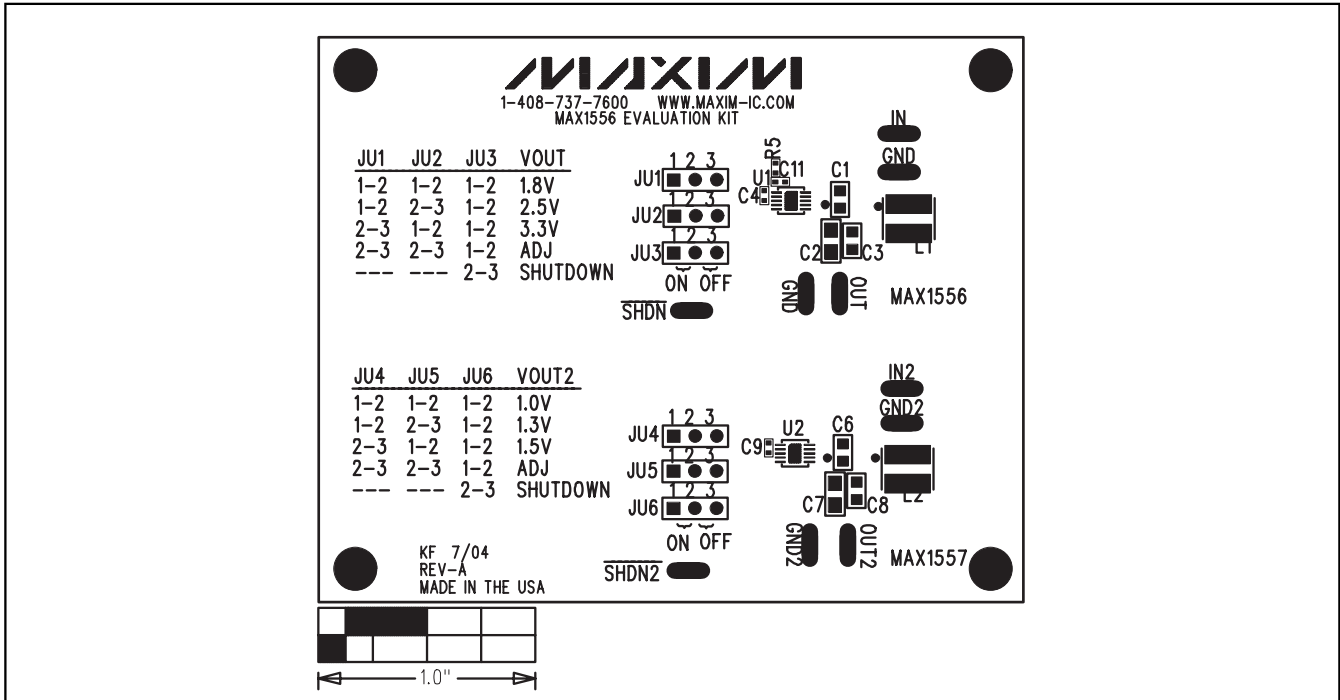

Figure 2. MAX1556 EV Kit Component Placement Guide—Component Side

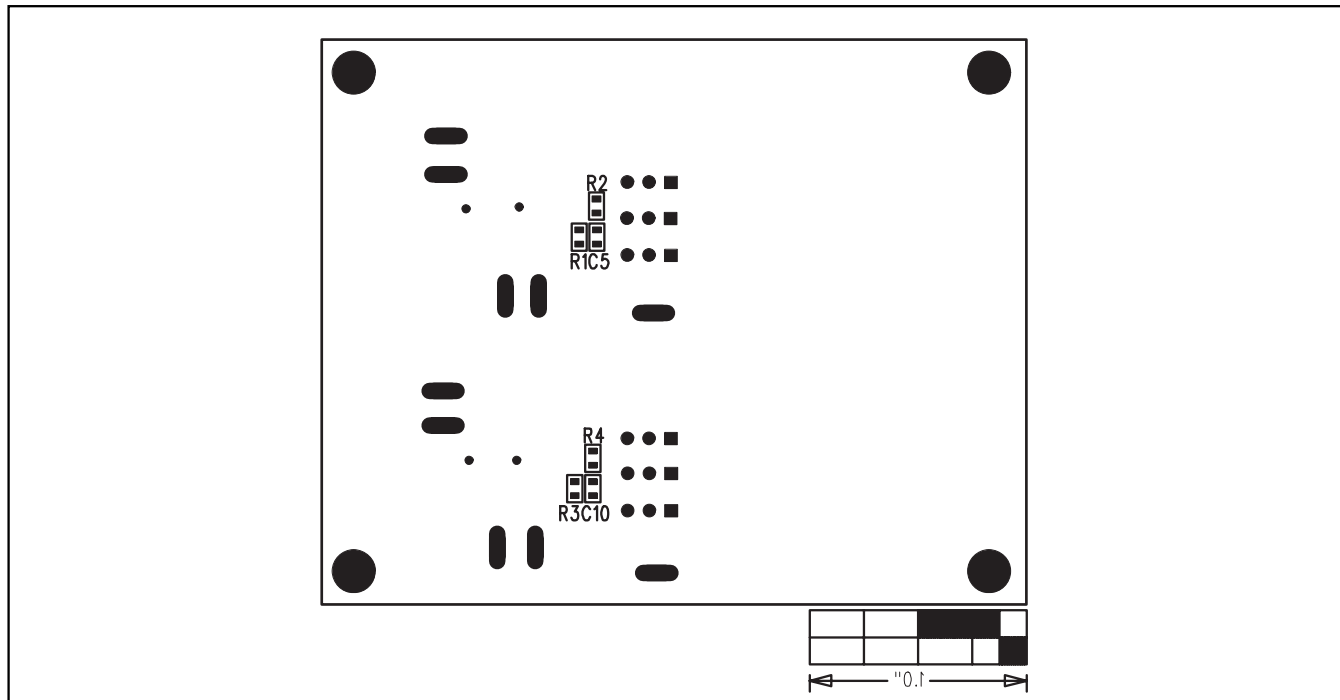

Figure 3. MAX1556 EV Kit Component Placement Guide—Solder Side

MAX1556 Evaluation Kit

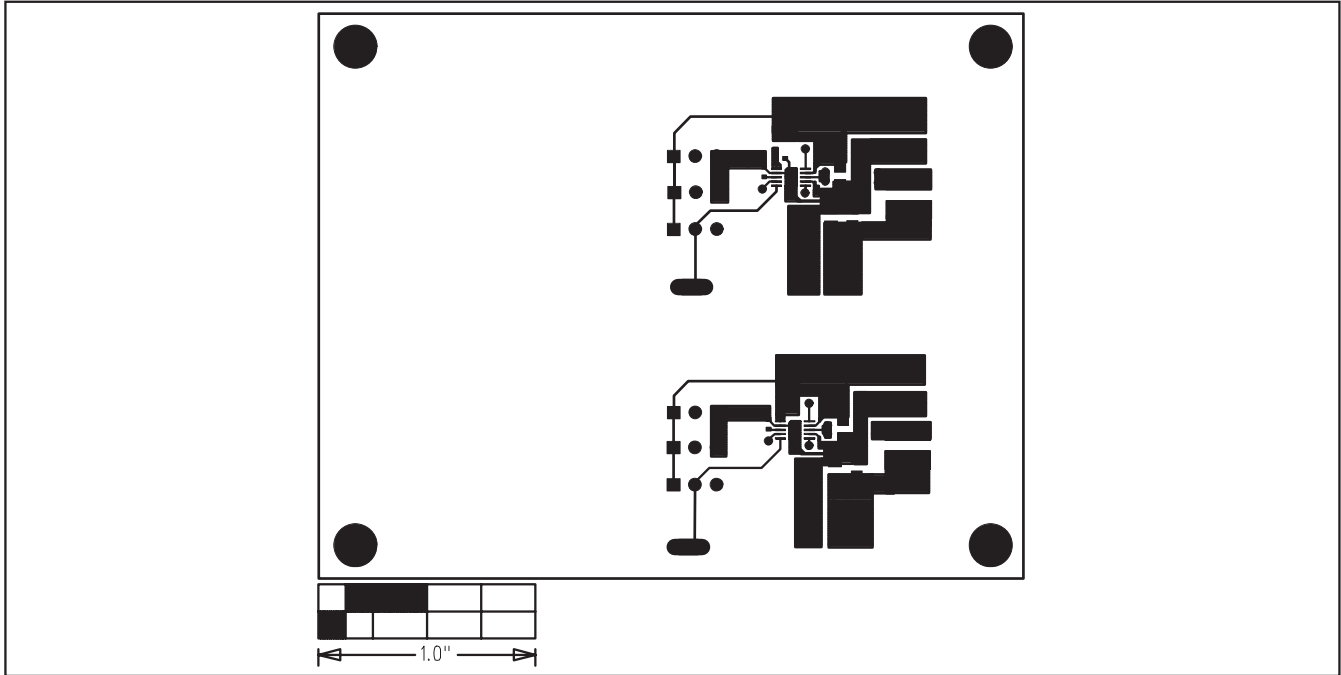

Figure 4. MAX1556 EV Kit PC Board Layout—Component Side

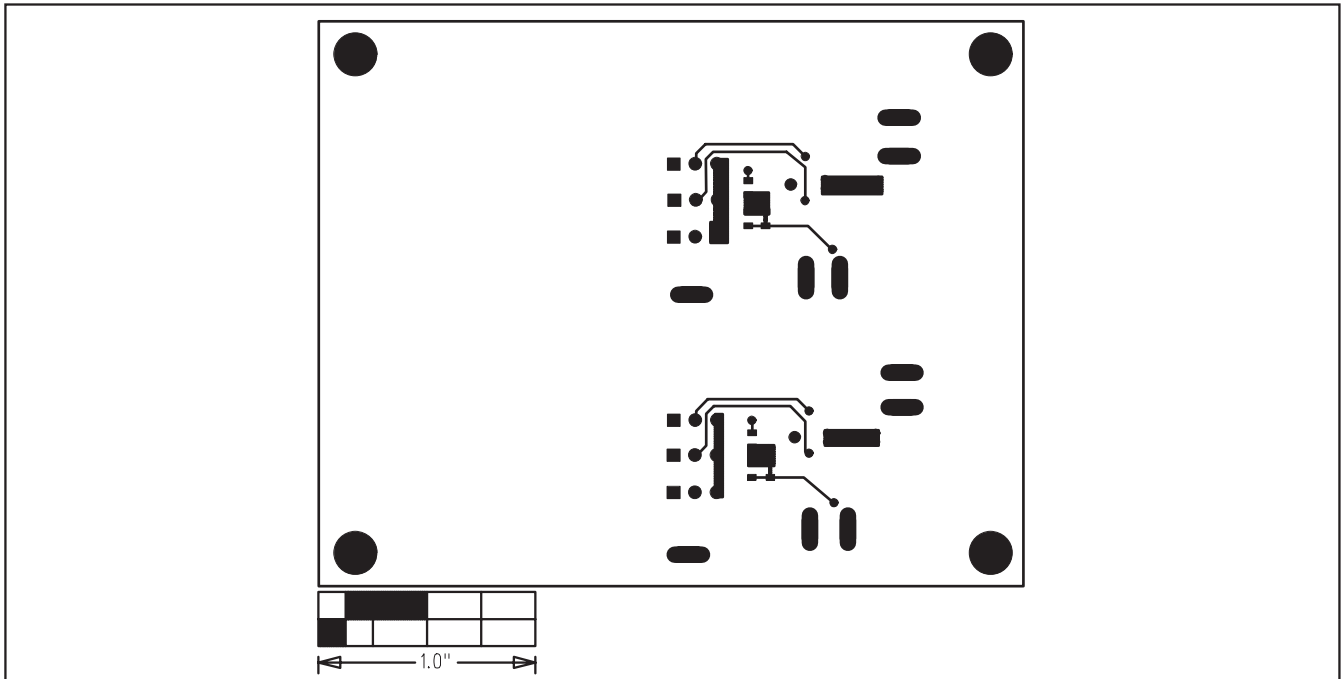

Figure 5. MAX1556 EV Kit PC Board Layout—Solder Side

Maxim cannot assume responsibility for use of any circuitry other than circuitry entirely embodied in a Maxim product. No circuit patent licenses are implied. Maxim reserves the right to change the circuitry and specifications without notice at any time.

6 _____ **Maxim Integrated Products, 120 San Gabriel Drive, Sunnyvale, CA 94086 408-737-7600**



Стандарт Электрон Связь

Мы молодая и активно развивающаяся компания в области поставок электронных компонентов. Мы поставляем электронные компоненты отечественного и импортного производства напрямую от производителей и с крупнейших складов мира.

Благодаря сотрудничеству с мировыми поставщиками мы осуществляем комплексные и плановые поставки широчайшего спектра электронных компонентов.

Собственная эффективная логистика и склад в обеспечивает надежную поставку продукции в точно указанные сроки по всей России.

Мы осуществляем техническую поддержку нашим клиентам и предпродажную проверку качества продукции. На все поставляемые продукты мы предоставляем гарантию .

Осуществляем поставки продукции под контролем ВП МО РФ на предприятия военно-промышленного комплекса России , а также работаем в рамках 275 ФЗ с открытием отдельных счетов в уполномоченном банке. Система менеджмента качества компании соответствует требованиям ГОСТ ISO 9001.

Минимальные сроки поставки, гибкие цены, неограниченный ассортимент и индивидуальный подход к клиентам являются основой для выстраивания долгосрочного и эффективного сотрудничества с предприятиями радиоэлектронной промышленности, предприятиями ВПК и научно-исследовательскими институтами России.

С нами вы становитесь еще успешнее!

Наши контакты:

Телефон: +7 812 627 14 35

Электронная почта: sales@st-electron.ru

Адрес: 198099, Санкт-Петербург,
Промышленная ул, дом № 19, литера Н,
помещение 100-Н Офис 331