

## Features

- Very Low DC Power Consumption: 100  $\mu$ W
- Low Insertion Loss: 0.5 dB
- High Isolation: 25 dB up to 2 GHz
- Very High Intercept Point: 45 dBm IP<sub>3</sub>
- Nanosecond Switching Speed
- Lead-Free SOIC-8 Package
- 100% Matte Tin Plating over Copper
- Halogen-Free "Green" Mold Compound
- 260°C Reflow Compatible
- RoHS\* Compliant Version of the SW-239

## Description

The MASWSS0157 is a GaAs MMIC SPDT switch in a lead-free SOIC 8-lead surface mount plastic package. This device is ideally suited for use where low power consumption is required.

Typical applications include transmit/receive switching, switch matrices and switched filter banks in systems such as radio and cellular equipment, PCM, GPS, fiber optic modules, and other battery powered radio equipment.

The MASWSS0157 is fabricated using a monolithic GaAs MMIC using a mature 1 micron process. The process features full chip passivation for increased performance and reliability.

## Ordering Information <sup>1</sup>

| Part Number       | Package           |
|-------------------|-------------------|
| MASWSS0157        | Bulk Packaging    |
| MASWSS0157TR      | 1000 piece reel   |
| MASWSS0157TR-3000 | 3000 piece reel   |
| MASWSS0157SMB     | Sample Test Board |

1. Reference Application Note M513 for reel size information.

## Functional Schematic

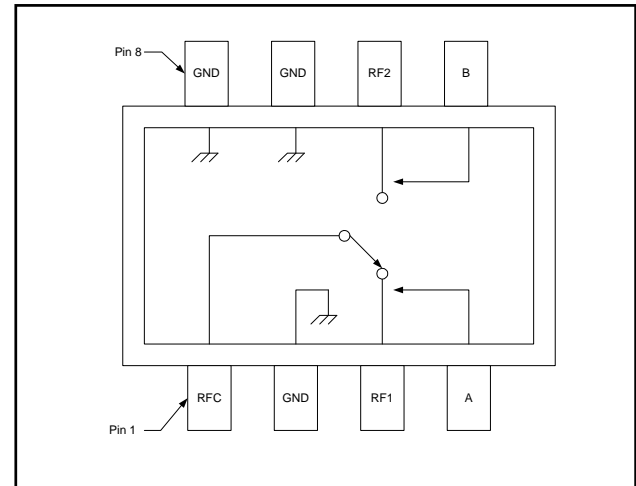

## Pin Configuration

| Pin No. | Function  |
|---------|-----------|
| 1       | RF Common |
| 2       | Ground    |
| 3       | RF Port 1 |
| 4       | Control A |
| 5       | Control B |
| 6       | RF Port 2 |
| 7       | Ground    |
| 8       | Ground    |

\* Restrictions on Hazardous Substances, European Union Directive 2002/95/EC.

**Electrical Specifications:  $T_A = 25^\circ\text{C}$ ,  $V_c = 0\text{ V} / -5\text{ V}$ ,  $Z_0 = 50\ \Omega$  <sup>2</sup>**

| Parameter              | Test Conditions   | Units         | Min. | Typ.  | Max. |
|------------------------|---|---------------|------|-------|------|
| Insertion Loss         | DC - 0.1 GHz  | dB            | —    | 0.4   | —    |
|                        | DC - 0.5 GHz  |               | —    | 0.4   | —    |
|                        | DC - 1.0 GHz  |               | —    | 0.5   | 0.8  |
|                        | DC - 2.0 GHz  |               | —    | 0.6   | —    |
| Isolation              | DC - 0.1 GHz  | dB            | —    | 56    | —    |
|                        | DC - 0.5 GHz  |               | —    | 43    | —    |
|                        | DC - 1.0 GHz  |               | 30   | 33    | —    |
|                        | DC - 2.0 GHz  |               | —    | 24    | —    |
| VSWR                   | DC - 2.0 GHz  | Ratio         | —    | 1.4:1 | —    |
| Trise, Tfall           | 10% to 90% RF, 90% to 10% RF  | ns            | —    | 2     | —    |
| Ton, Toff              | 50% Control to 90% RF, 50% Control to 10% RF  | ns            | —    | 4     | —    |
| Transients             | In-Band   | mV            | —    | 15    | —    |
| 1 dB Compression Point | Input Power, 0.05 GHz   | dBm           | —    | 21    | —    |
|                        | Input Power, 0.5 - 2.0 GHz  |               | —    | 27    | —    |
| 2nd Order Intercept    | Measured Relative to Input Power<br>(for two-tone input power up to +6 dBm)<br>0.05 GHz | dBm           | —    | 55    | —    |
|                        | 0.5 - 2.0 GHz   |               | —    | 68    | —    |
| 3rd Order Intercept    | Measured Relative to Input Power<br>(for two-tone input power up to +6 dBm)<br>0.05 GHz | dBm           | —    | 40    | —    |
|                        | 0.5 - 2.0 GHz   |               | —    | 45    | —    |
| Control Current        | $\frac{1}{2}V_c\frac{1}{2} = 5\text{ V}$  | $\mu\text{A}$ | —    | 20    | 25   |

2. For positive voltage control, external DC blocking capacitors are required on all RF ports as well as the Ground ports which should be pulled up to the positive voltage control level. (Refer to Application Note M521 - "Positive Voltage Control of GaAs MMIC Control Devices").

### Absolute Maximum Ratings <sup>3,4</sup>

| Parameter                                | Absolute Maximum                            |
|--|---|
| Input Power<br>0.05 GHz<br>0.5 - 2.0 GHz | +27 dBm<br>+34 dBm                          |
| Control Voltage                          | $-8.5\text{ V} \leq V_c \leq +5\text{ V}$   |
| Operating Temperature                    | $-40^\circ\text{C}$ to $+85^\circ\text{C}$  |
| Storage Temperature                      | $-65^\circ\text{C}$ to $+150^\circ\text{C}$ |

3. Exceeding any one or combination of these limits may cause permanent damage to this device.  
4. M/A-COM does not recommend sustained operation near these survivability limits.

### Truth Table <sup>5</sup>

| Control Inputs |   | Condition of Switch<br>RF Common to each RF Port |     |
|----------------|---|--|-----|
| A              | B | RF1  | RF2 |
| 1              | 0 | On   | Off |
| 0              | 1 | Off  | On  |

5. 0 = 0 V to -0.2 V, 1 = -5 V to -8 V

2

**ADVANCED:** Data Sheets contain information regarding a product M/A-COM Technology Solutions is considering for development. Performance is based on target specifications, simulated results, and/or prototype measurements. Commitment to develop is not guaranteed.

**PRELIMINARY:** Data Sheets contain information regarding a product M/A-COM Technology Solutions has under development. Performance is based on engineering tests. Specifications are typical. Mechanical outline has been fixed. Engineering samples and/or test data may be available. Commitment to produce in volume is not guaranteed.

• **North America** Tel: 800.366.2266 • **Europe** Tel: +353.21.244.6400  
• **India** Tel: +91.80.43537383 • **China** Tel: +86.21.2407.1588  
Visit [www.macomtech.com](http://www.macomtech.com) for additional data sheets and product information.

M/A-COM Technology Solutions Inc. and its affiliates reserve the right to make changes to the product(s) or information contained herein without notice.

## Typical Performance Curves

**Insertion Loss**

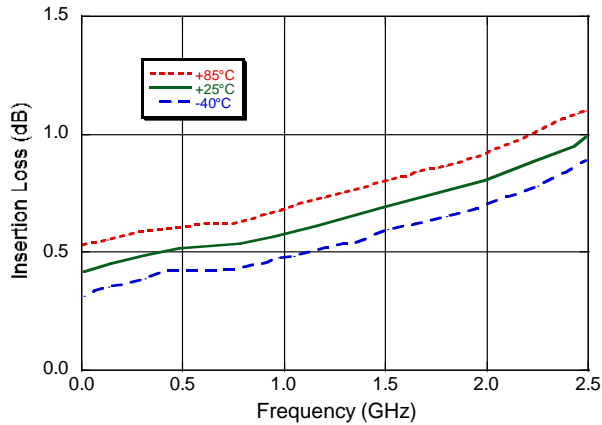

**Isolation**

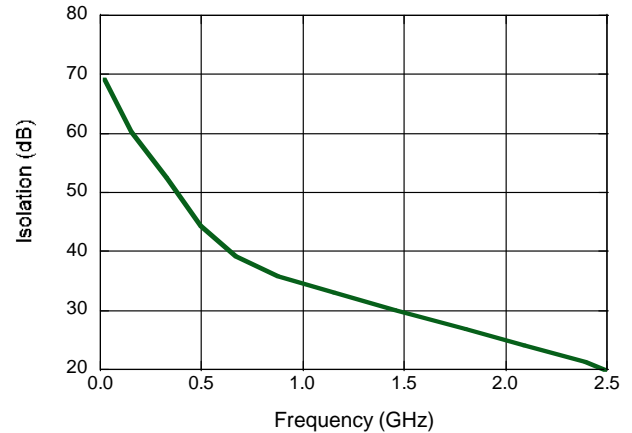

**VSWR**

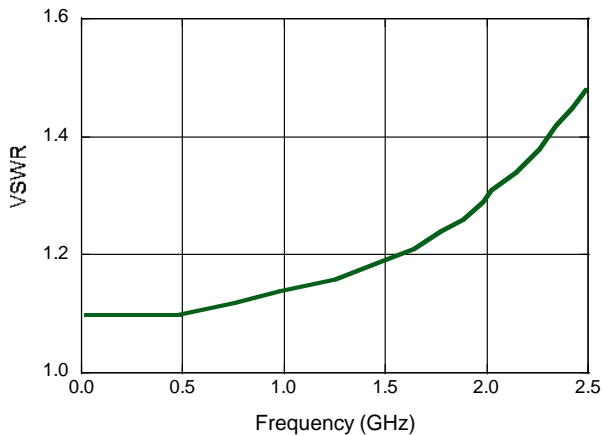

**Electrical Schematic**

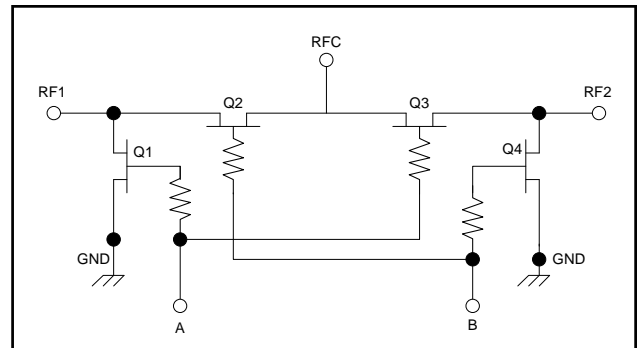

## Lead-Free SOIC-8<sup>†</sup>

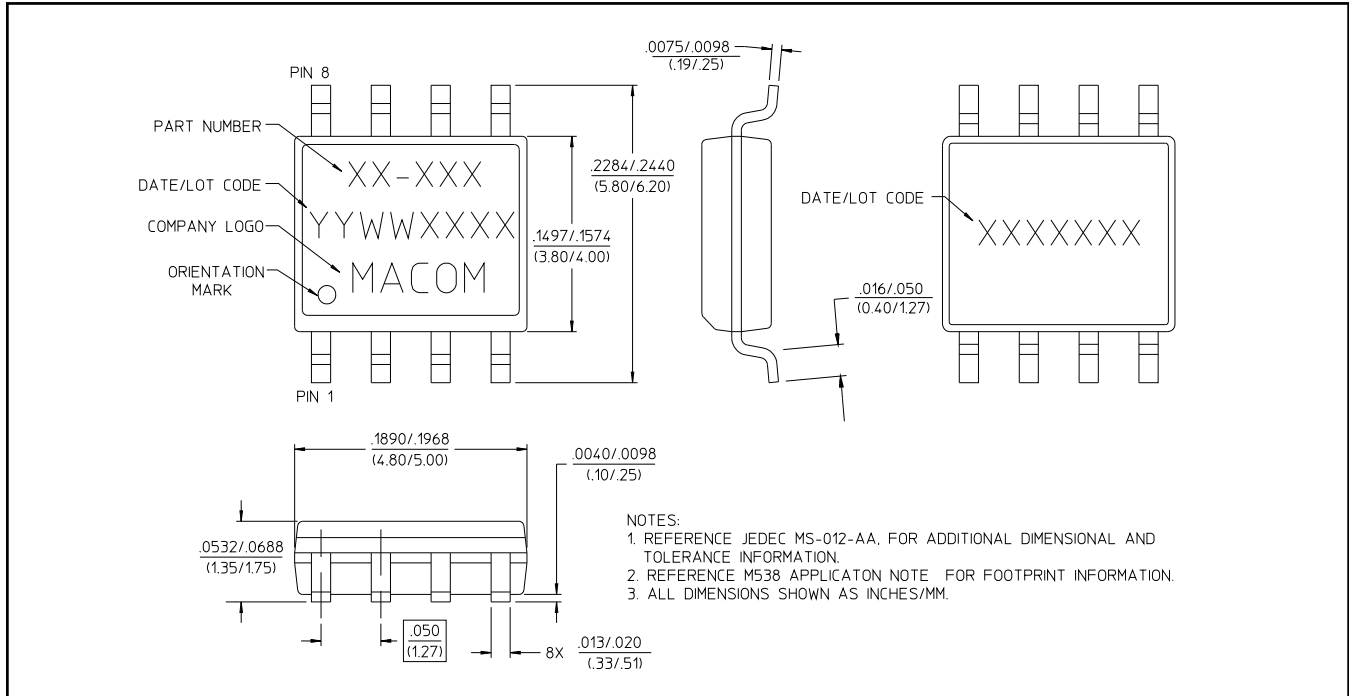

<sup>†</sup> Reference Application Note M538 for lead-free solder reflow recommendations.

## Handling Procedures

Please observe the following precautions to avoid damage:

## Static Sensitivity

Gallium Arsenide Integrated Circuits are sensitive to electrostatic discharge (ESD) and can be damaged by static electricity. Proper ESD control techniques should be used when handling these devices.



## Стандарт Электрон Связь

Мы молодая и активно развивающаяся компания в области поставок электронных компонентов. Мы поставляем электронные компоненты отечественного и импортного производства напрямую от производителей и с крупнейших складов мира.

Благодаря сотрудничеству с мировыми поставщиками мы осуществляем комплексные и плановые поставки широчайшего спектра электронных компонентов.

Собственная эффективная логистика и склад в обеспечивает надежную поставку продукции в точно указанные сроки по всей России.

Мы осуществляем техническую поддержку нашим клиентам и предпродажную проверку качества продукции. На все поставляемые продукты мы предоставляем гарантию .

Осуществляем поставки продукции под контролем ВП МО РФ на предприятия военно-промышленного комплекса России , а также работаем в рамках 275 ФЗ с открытием отдельных счетов в уполномоченном банке. Система менеджмента качества компании соответствует требованиям ГОСТ ISO 9001.

Минимальные сроки поставки, гибкие цены, неограниченный ассортимент и индивидуальный подход к клиентам являются основой для выстраивания долгосрочного и эффективного сотрудничества с предприятиями радиоэлектронной промышленности, предприятиями ВПК и научно-исследовательскими институтами России.

С нами вы становитесь еще успешнее!

### Наши контакты:

**Телефон:** +7 812 627 14 35

**Электронная почта:** [sales@st-electron.ru](mailto:sales@st-electron.ru)

**Адрес:** 198099, Санкт-Петербург,  
Промышленная ул, дом № 19, литера Н,  
помещение 100-Н Офис 331