

## SLLIMM™-nano small low-loss intelligent molded module IPM, 3-phase inverter, 1 A, 3.6 Ω max., 500 V MOSFET

Datasheet - production data

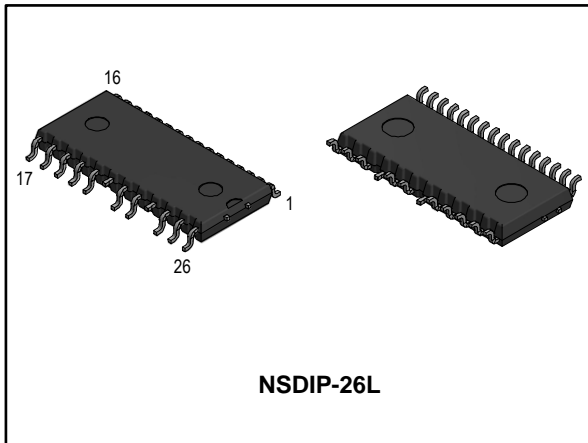

### Applications

- 3-phase inverters for small power motor drives
- Small appliance, roller shutters, heating systems, fans and pumps

### Description

This SLLIMM (small low-loss intelligent molded module) nano provides a compact, high-performance AC motor drive in a simple, rugged design. It is composed of six MOSFETs and three half-bridge HVICs for gate driving, providing low electromagnetic interference (EMI) characteristics with optimized switching speed. The package is optimized for thermal performance and compactness in built-in motor applications, or other low power applications where assembly space is limited. This IPM includes a comparator that can be used to design a fast and efficient protection circuit. SLLIMM™ is a trademark of STMicroelectronics.

### Features

- IPM 1 A, 500 V,  $R_{DS(on)} = 3.6 \Omega$ , 3-phase MOSFET inverter bridge including control ICs for gate driving
- Optimized for low electromagnetic interference
- 3.3 V, 5 V, 15 V CMOS/TTL input comparators with hysteresis and pull-down/pull-up resistors
- Undervoltage lockout
- Internal bootstrap diode
- Interlocking function
- Comparator for fault protection against overtemperature and overcurrent
- Optimized pinout for easy board layout
- NTC for temperature control (UL 1434 CA 2 and 4)
- Moisture sensitive level (MSL) 3

**Table 1: Device summary**

Order code	Marking	Package	Packing
STIPNS1M50SDT-H	IPNS1M50SDT-H	NSDIP-26L	Tape and reel

---

## Contents

<b>1</b>	<b>Internal schematic diagram and pin configuration .....</b>	<b>3</b>
<b>2</b>	<b>Electrical ratings .....</b>	<b>6</b>
2.1	Absolute maximum ratings .....	6
2.2	Thermal data .....	6
<b>3</b>	<b>Electrical characteristics .....</b>	<b>7</b>
3.1	Inverter part .....	7
3.2	Control part .....	9
3.2.1	NTC thermistor .....	11
3.3	Waveform definitions .....	12
<b>4</b>	<b>Smart shutdown function .....</b>	<b>13</b>
<b>5</b>	<b>Application circuit example .....</b>	<b>15</b>
5.1	Guidelines .....	16
<b>6</b>	<b>Package information .....</b>	<b>17</b>
6.1	NSDIP-26L package information .....	17
<b>7</b>	<b>Revision history .....</b>	<b>20</b>

# 1 Internal schematic diagram and pin configuration

Figure 1: Internal schematic diagram

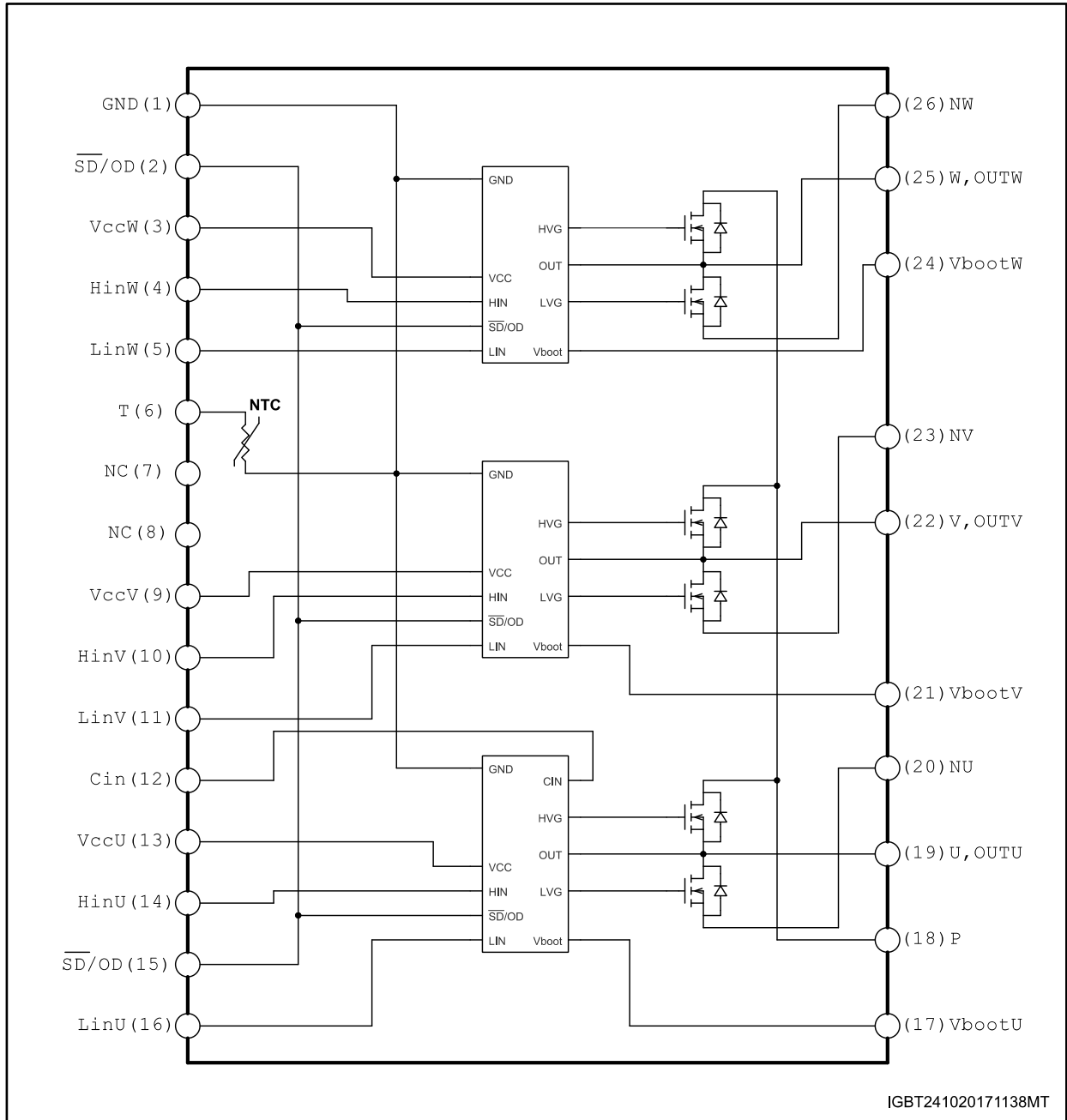
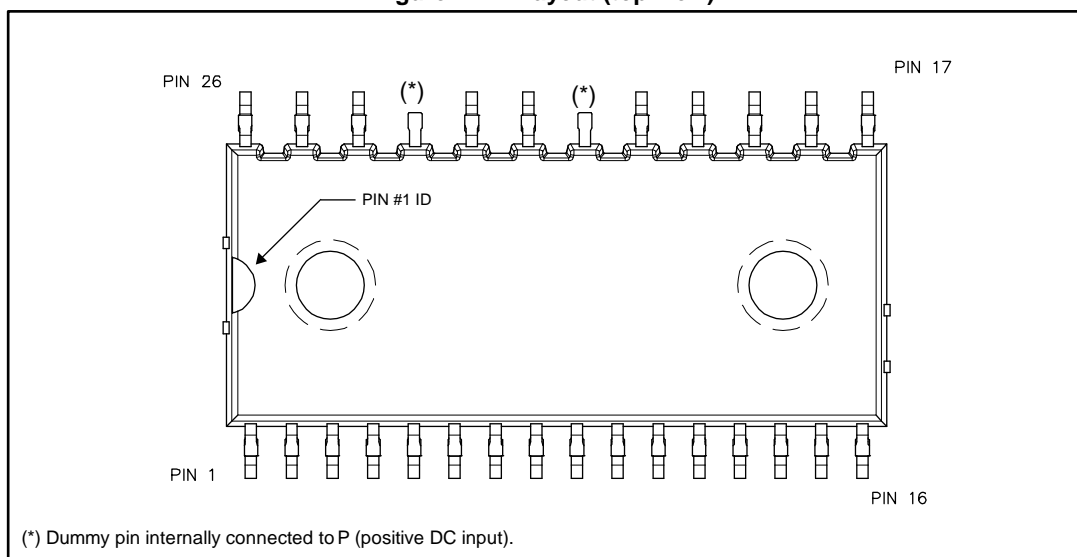

Table 2: Pin description

Pin	Symbol	Description
1	GND	Ground
2	$\overline{SD}/OD$	Shutdown logic input (active low) / open-drain (comparator output)
3	V <sub>CC</sub> W	Low voltage power supply W phase
4	HIN W	High-side logic input for W phase
5	LIN W	Low-side logic input for W phase
6	T	NTC thermistor terminal
7	NC	-
8	NC	-
9	V <sub>CC</sub> V	Low voltage power supply V phase
10	HIN V	High-side logic input for V phase
11	LIN V	Low-side logic input for V phase
12	CIN	Comparator input
13	V <sub>CC</sub> U	Low voltage power supply for U phase
14	HIN U	High-side logic input for U phase
15	$\overline{SD}/OD$	Shutdown logic input (active low) / open-drain (comparator output)
16	LIN U	Low-side logic input for U phase
17	V <sub>BOOT</sub> U	Bootstrap voltage for U phase
18	P	Positive DC input
19	U, OUT <sub>U</sub>	U phase output
20	N <sub>U</sub>	Negative DC input for U phase
21	V <sub>BOOT</sub> V	Bootstrap voltage for V phase
22	V, OUT <sub>V</sub>	V phase output
23	N <sub>V</sub>	Negative DC input for V phase
24	V <sub>BOOT</sub> W	Bootstrap voltage for W phase
25	W, OUT <sub>W</sub>	W phase output
26	N <sub>W</sub>	Negative DC input for W phase

Figure 2: Pin layout (top view)



## 2 Electrical ratings

### 2.1 Absolute maximum ratings

Table 3: Inverter part

Symbol	Parameter	Value	Unit
$V_{DSS}$	MOSFET blocking voltage (or drain-source voltage) for each MOSFET ( $V_{IN}^{(1)} = 0$ )	500	V
$\pm I_D$	Continuous current each MOSFET	1	A
$\pm I_{DP}^{(2)}$	Peak drain current each MOSFET (less than 1 ms)	2	A
$P_{TOT}$	Each MOSFET total dissipation at $T_C = 25\text{ °C}$	10.8	W

**Notes:**

(1) Applied among HINi, LINi and GND for  $i = U, V, W$ .

(2) Pulse width limited by max. junction temperature.

Table 4: Control part

Symbol	Parameter	Min.	Max.	Unit
$V_{OUT}$	Output voltage applied among $OUT_U, OUT_V, OUT_W - GND$	$V_{boot} - 21$	$V_{boot} + 0.3$	V
$V_{CC}$	Low voltage power supply	- 0.3	21	V
$V_{CIN}$	Comparator input voltage	- 0.3	$V_{CC} + 0.3$	V
$V_{boot}$	Bootstrap voltage	- 0.3	620	V
$V_{IN}$	Logic input voltage applied among HIN, LIN and GND	- 0.3	15	V
$V/\overline{SD}/OD$	Open-drain voltage	- 0.3	15	V
$\Delta V_{OUT}/dT$	Allowed output slew rate		50	V/ns

Table 5: Total system

Symbol	Parameter	Value	Unit
$V_{ISO}$	Isolation withstand voltage applied between each pin and heatsink plate (AC voltage, $t = 60\text{ s}$ )	1000	V
$T_j$	Power chip operating junction temperature range	-40 to 150	°C
$T_C$	Module case operation temperature range	-40 to 125	°C

### 2.2 Thermal data

Table 6: Thermal data

Symbol	Parameter	Value	Unit
$R_{th(j-c)}$	Thermal resistance junction-case	11.5	°C/W

### 3 Electrical characteristics

$T_J = 25\text{ }^\circ\text{C}$  unless otherwise specified.

#### 3.1 Inverter part

Table 7: Static

Symbol	Parameter	Test conditions	Min.	Typ.	Max.	Unit
$I_{DSS}$	Zero-gate voltage drain current	$V_{DS} = 500\text{ V}$ , $V_{CC} = 15\text{ V}$ ; $V_{Boot} = 15\text{ V}$			1	mA
$V_{(BR)DSS}$	Drain-source breakdown voltage	$V_{CC} = V_{boot} = 15\text{ V}$ , $V_{IN}^{(1)} = 0\text{ V}$ , $I_D = 1\text{ mA}$	500			V
$R_{DS(on)}$	Static drain source turn-on resistance	$V_{CC} = V_{boot} = 15\text{ V}$ , $V_{IN}^{(1)} = 0 - 5\text{ V}$ , $I_D = 0.5\text{ A}$		3.2	3.6	$\Omega$
$V_{SD}$	Drain-source diode forward voltage	$V_{IN}^{(1)} = 0$ "logic state", $I_D = 1\text{ A}$		0.9	1.6	V

**Notes:**

<sup>(1)</sup>Applied among HINx, LINx and GND for x=U,V,W.

Table 8: Inductive load switching time and energy

Symbol	Parameter	Test conditions	Min.	Typ.	Max.	Unit
$t_{on}^{(1)}$	Turn-on time	$V_{DD} = 300\text{ V}$ , $V_{CC} = V_{boot} = 15\text{ V}$ , $V_{IN}^{(2)} = 0 - 5\text{ V}$ , $I_C = 0.5\text{ A}$ (see <a href="#">Figure 4: "Switching time definition"</a> )	-	226	-	ns
$t_{c(on)}^{(1)}$	Crossover time (on)		-	130	-	
$t_{off}^{(1)}$	Turn-off time		-	248	-	
$t_{c(off)}^{(1)}$	Crossover time (off)		-	56	-	
$t_{rr}$	Reverse recovery time		-	155	-	
$E_{on}$	Turn-on switching energy		-	25	-	$\mu\text{J}$
$E_{off}$	Turn-off switching energy		-	3.8	-	

**Notes:**

<sup>(1)</sup> $t_{ON}$  and  $t_{OFF}$  include the propagation delay time of the internal drive.  $t_{c(ON)}$  and  $t_{c(OFF)}$  are the switching time of MOSFET itself under the internally given gate driving conditions.

<sup>(2)</sup>Applied among HINx, LINx and GND for x=U,V,W.

Figure 3: Switching time test circuit



Figure 4: Switching time definition

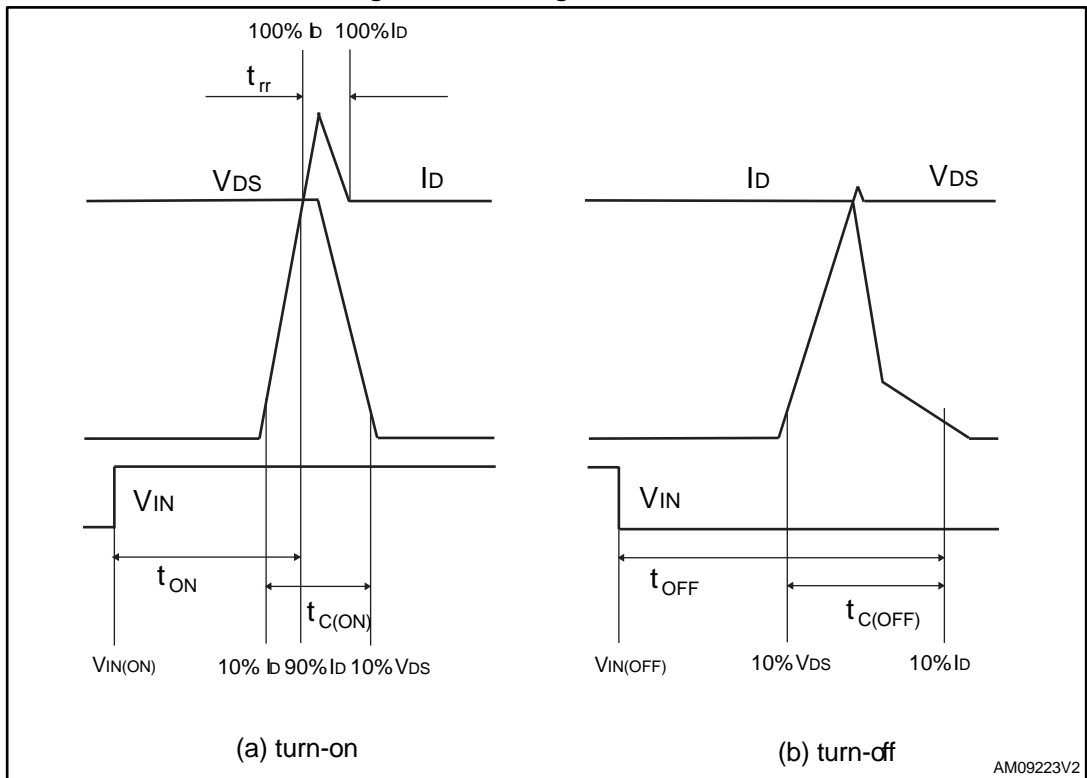

Figure 4: "Switching time definition" refers to HIN, LIN inputs (active high).



### 3.2 Control part

( $V_{CC} = 15\text{ V}$  unless otherwise specified).

**Table 9: Low voltage power supply**

Symbol	Parameter	Test conditions	Min.	Typ.	Max.	Unit
$V_{CC\_hys}$	$V_{CC}$ UV hysteresis		1.2	1.5	1.8	V
$V_{CC\_thON}$	$V_{CC}$ UV turn ON threshold		11.5	12	12.5	V
$V_{CC\_thOFF}$	$V_{CC}$ UV turn OFF threshold		10	10.5	11	V
$I_{qccu}$	Undervoltage quiescent supply current	$V_{CC} = 10\text{ V}$ , $\overline{SD}/OD = 5\text{ V}$ ; $LIN = 0\text{ V}$ ; $HIN = 0$ , $CIN = 0$			150	$\mu\text{A}$
$I_{qcc}$	Quiescent current	$V_{CC} = 15\text{ V}$ , $\overline{SD}/OD = 5\text{ V}$ ; $LIN = 0\text{ V}$ ; $HIN = 0$ , $CIN = 0$			1	mA
$V_{ref}$	Internal comparator (CIN) reference voltage		0.5	0.54	0.58	V

**Table 10: Bootstrapped voltage**

Symbol	Parameter	Test conditions	Min.	Typ.	Max.	Unit
$V_{BS\_hys}$	$V_{BS}$ UV hysteresis		1.2	1.5	1.8	V
$V_{BS\_thON}$	$V_{BS}$ UV turn-ON threshold		11.1	11.5	12.1	V
$V_{BS\_thOFF}$	$V_{BS}$ UV turn-OFF threshold		9.8	10	10.6	V
$I_{qBSU}$	Undervoltage $V_{BS}$ quiescent current	$V_{BS} < 9\text{ V}$ ; $\overline{SD}/OD = 5\text{ V}$ ; $LIN = 0\text{ V}$ and $HIN = 5\text{ V}$ ; $CIN = 0$		70	110	$\mu\text{A}$
$I_{qBS}$	$V_{BS}$ quiescent current	$V_{BS} = 15\text{ V}$ ; $\overline{SD}/OD = 5\text{ V}$ ; $LIN = 0\text{ V}$ and $HIN = 5\text{ V}$ ; $CIN = 0$		200	300	$\mu\text{A}$
$R_{DS(on)}$	Bootstrap driver on-resistance	LVG ON		120		$\Omega$

**Table 11: Logic inputs**

Symbol	Parameter	Test conditions	Min.	Typ.	Max.	Unit
$V_{il}$	Low logic level voltage				0.8	V
$V_{ih}$	High logic level voltage		2.25			V
$I_{HINh}$	HIN logic "1" input bias current	$HIN = 15\text{ V}$	20	40	100	$\mu\text{A}$
$I_{HINl}$	HIN logic "0" input bias current	$HIN = 0\text{ V}$			1	$\mu\text{A}$
$I_{LINh}$	LIN logic "1" input bias current	$LIN = 15\text{ V}$	20	40	100	$\mu\text{A}$
$I_{LINl}$	LIN logic "0" input bias current	$LIN = 0\text{ V}$			1	$\mu\text{A}$
$I_{SDh}$	$\overline{SD}$ logic "0" input bias current	$\overline{SD} = 15\text{ V}$	220	295	370	$\mu\text{A}$
$I_{SDl}$	$\overline{SD}$ logic "1" input bias current	$\overline{SD} = 0\text{ V}$			3	$\mu\text{A}$
$Dt$	Dead time	See <a href="#">Figure 7: "Dead time and interlocking waveform definitions"</a>		180		ns

Table 12: Sense comparator characteristics

Symbol	Parameter	Test conditions	Min.	Typ.	Max.	Unit
$I_{ib}$	Input bias current	$V_{CIN} = 1\text{ V}$			1	$\mu\text{A}$
$V_{od}$	Open-drain low level output voltage	$I_{od} = 3\text{ mA}$			0.5	V
$R_{ON\_OD}$	Open-drain low level output resistance	$I_{od} = 3\text{ mA}$		166		$\Omega$
$R_{PD\_SD}$	$\overline{SD}$ pull-down resistor <sup>(1)</sup>			125		k $\Omega$
$t_{d\_comp}$	Comparator delay	$\overline{SD}/OD$ pulled to 5 V through 100 k $\Omega$ resistor		90	130	ns
SR	Slew rate	$C_L = 180\text{ pF}$ ; $R_{pu} = 5\text{ k}\Omega$		60		V/ $\mu\text{s}$
$t_{sd}$	Shutdown to high- / low-side driver propagation delay	$V_{OUT} = 0$ , $V_{boot} = V_{CC}$ , $V_{IN} = 0$ to 3.3 V	50	125	200	ns
$t_{isd}$	Comparator triggering to high- / low-side driver turn-off propagation delay	Measured applying a voltage step from 0 V to 3.3 V to pin CIN	50	200	250	

**Notes:**

<sup>(1)</sup>Equivalent values as a result of the resistances of three drivers in parallel.

Table 13: Truth table

Condition	Logic input ( $V_i$ )			Output	
	$\overline{SD}/OD$	LIN	HIN	LVG	HVG
Shutdown enable half-bridge tri-state	L	X <sup>(1)</sup>	X <sup>(1)</sup>	L	L
Interlocking half-bridge tri-state	H	H	H	L	L
0 "logic state" half-bridge tri-state	H	L	L	L	L
1 "logic state" low-side direct driving	H	H	L	H	L
1 "logic state" high-side direct driving	H	L	H	L	H

**Notes:**

<sup>(1)</sup>X: don't care.

3.2.1 NTC thermistor

Table 14: NTC thermistor

Symbol	Parameter	Test conditions	Min.	Typ.	Max.	Unit
R25	Resistance	T = 25 °C		85		kΩ
R100	Resistance	T = 100 °C		5388		Ω
B	B-constant	T = 25 °C to 100 °C		4092		K
T	Operating temperature		-25		125	°C

$$R(T) = R_{25} \times e^{B\left(\frac{1}{T} - \frac{1}{298}\right)}$$

Where T are temperatures in Kelvins

Figure 5: NTC resistance vs temperature

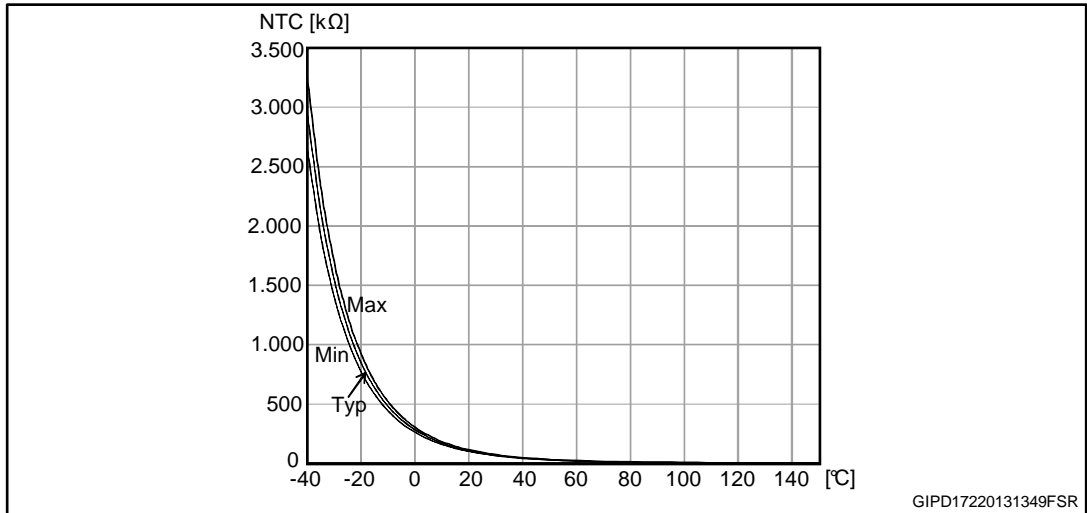
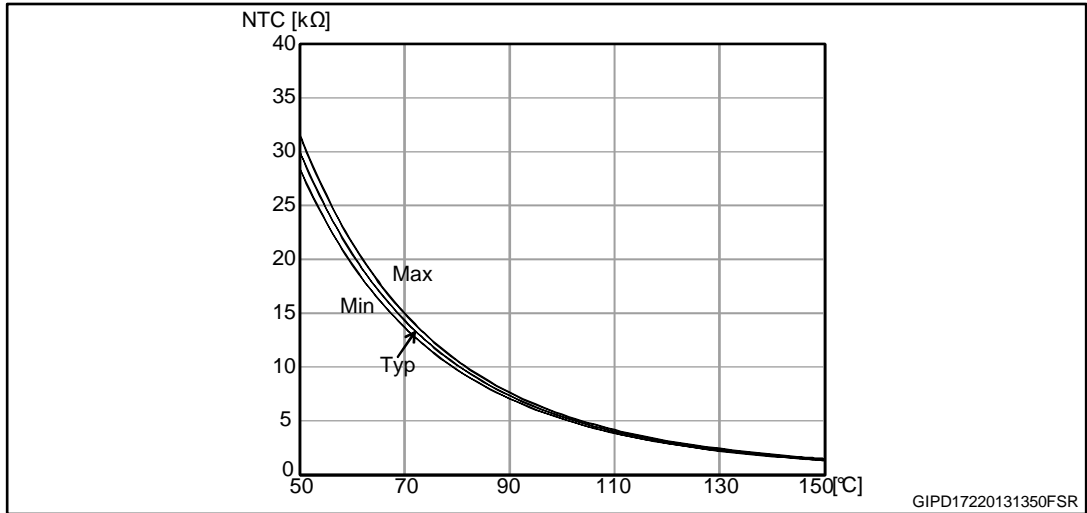
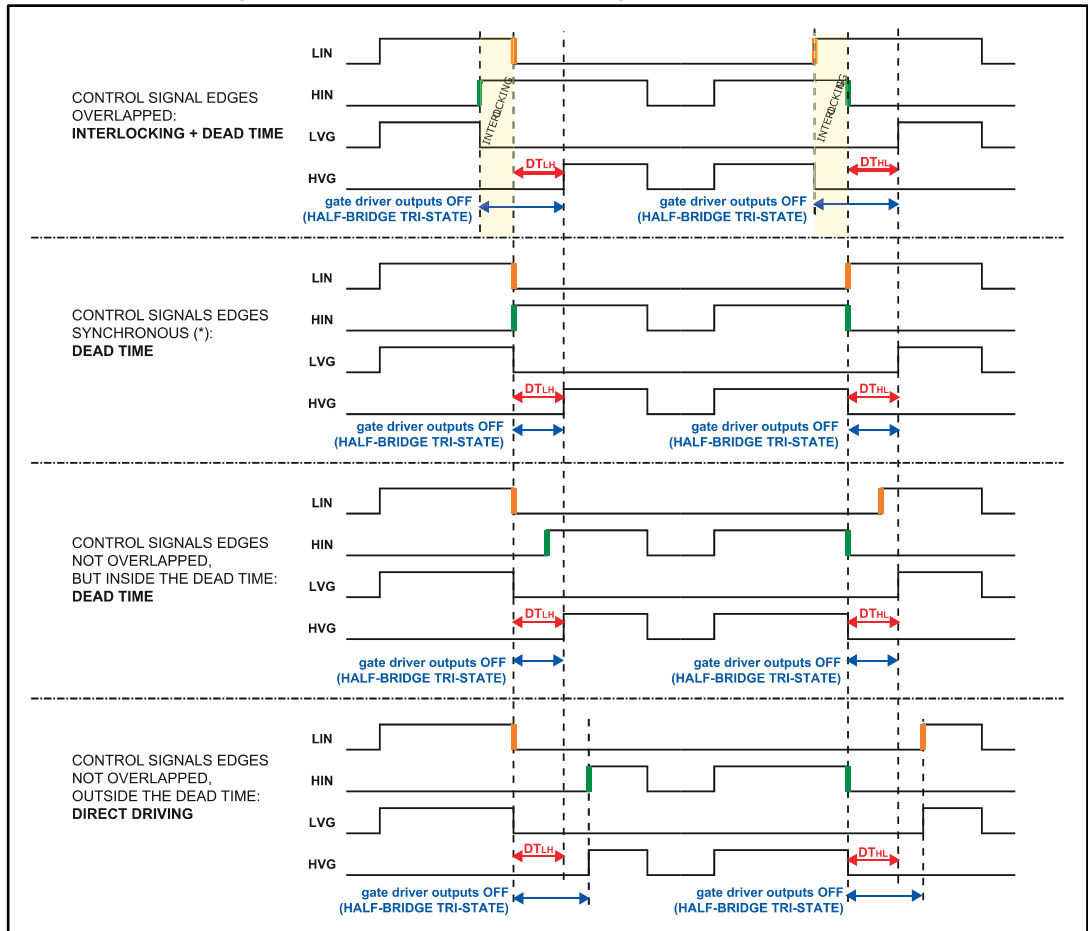

Figure 6: NTC resistance vs temperature (zoom)



### 3.3 Waveform definitions

Figure 7: Dead time and interlocking waveform definitions



## 4 Smart shutdown function

The device integrates a comparator for fault sensing purposes. The comparator has an internal voltage reference  $V_{REF}$  connected to the inverting input, while the non-inverting input on pin (CIN) can be connected to an external shunt resistor for simple overcurrent protection.

When the comparator triggers, the device is set to the shutdown state and both of its outputs are set to the low level, causing the half-bridge to enter a tri-state.

In common overcurrent protection architectures, the comparator output is usually connected to the shutdown input through an RC network so to provide a monostable circuit which implements a protection time following to a fault condition.

Our smart shutdown architecture immediately turns off the output gate driver in case of overcurrent through a preferential path for the fault signal which directly switches off the outputs. The time delay between the fault and output shutdown no longer depends on the RC values of the external network connected to the shutdown pin. At the same time, the DMOS connected to the open-drain output (pin  $\overline{SD}/OD$ ) is turned on by the internal logic, which holds it on until the shutdown voltage is lower than the minimum value of logic input threshold.

Besides, the smart shutdown function allows the real disable time to be increased while the constant time of the external RC network remains as it is.

Figure 8: Smart shutdown timing waveforms

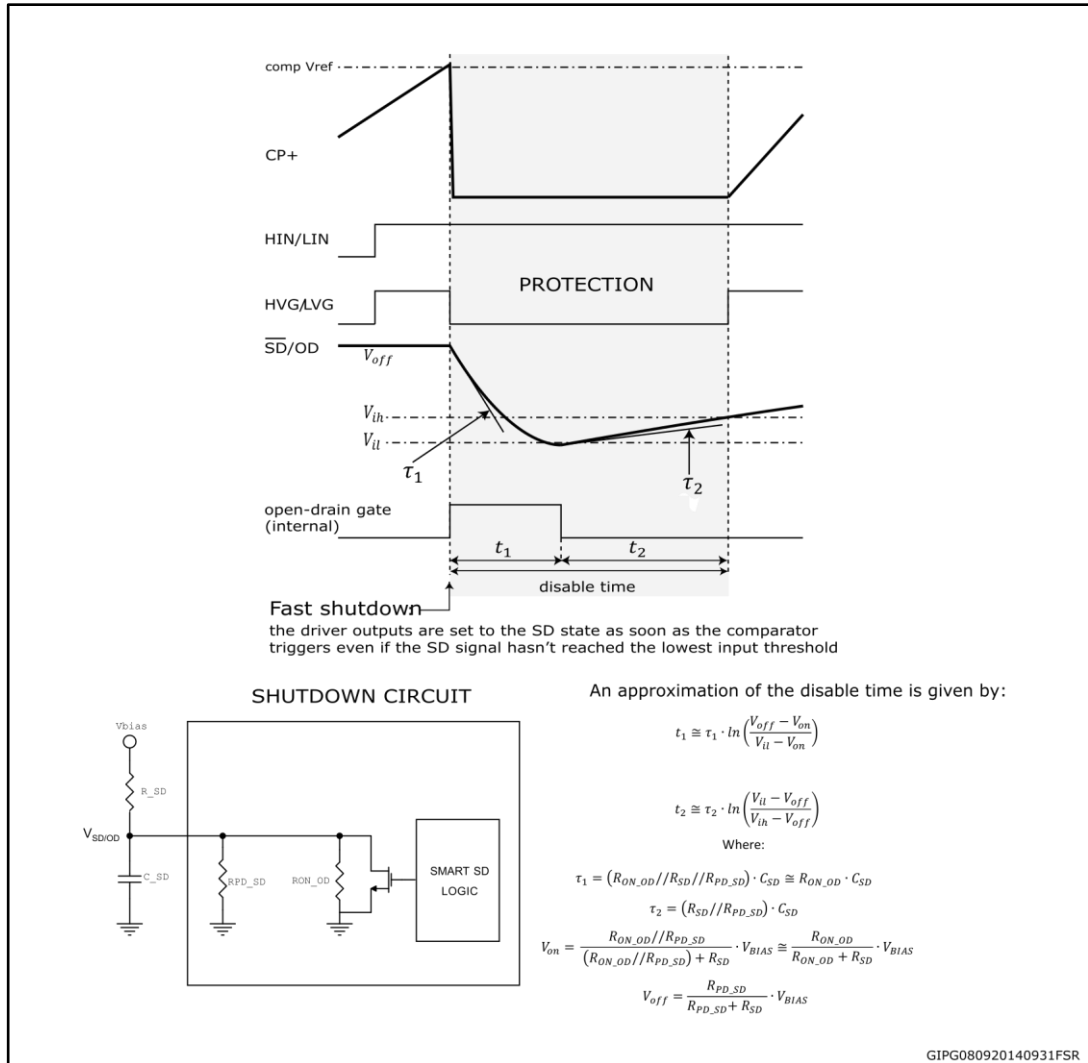

Please refer to [Table 12: "Sense comparator characteristics"](#) for internal propagation delay time details.

# 5 Application circuit example

Figure 9: Application circuit example

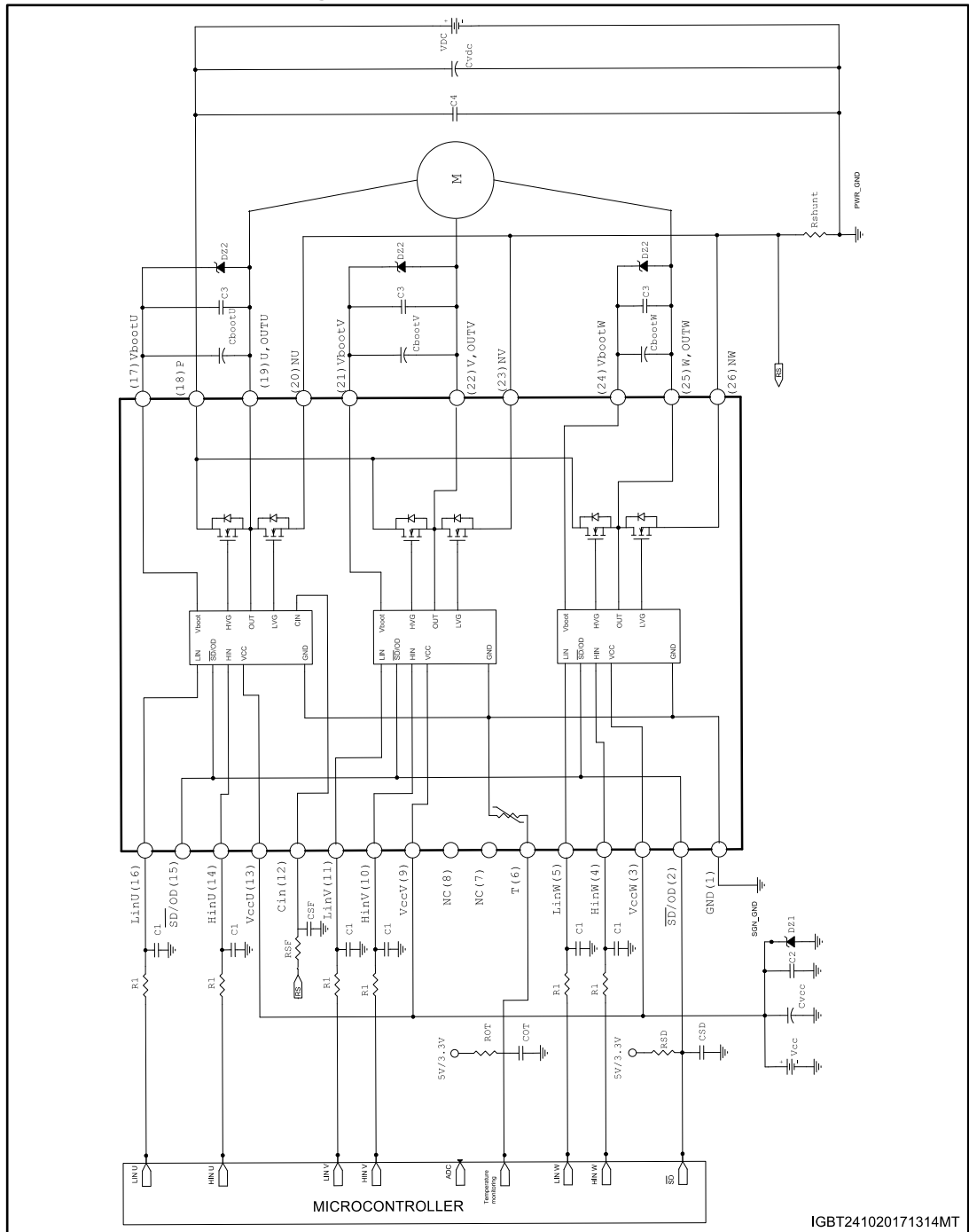

Application designers are free to use a different scheme according to the specifications of the device.

## 5.1 Guidelines

- Input signals HIN, LIN are active high logic. A 375 k $\Omega$  (typ.) pull-down resistor is built-in for each input. To prevent the input signal oscillation, the wiring of each input should be as short as possible and the use of RC filters ( $R_1$ ,  $C_1$ ) on each input signal is suggested. The filters should be with a time constant of about 100 ns and placed as close as possible to the IPM input pins.
- The use of a bypass capacitor CVCC (aluminum or tantalum) can help to reduce the transient circuit demand on the power supply. Besides, to reduce high frequency switching noise distributed on the power lines, a decoupling capacitor  $C_2$  (100 to 220 nF, with low ESR and low ESL) should be placed as close as possible to  $V_{CC}$  pin and in parallel with the bypass capacitor.
- The use of RC filter (RSF, CSF) is recommended to avoid protection circuit malfunction. The time constant ( $RSF \times CSF$ ) should be set to 1  $\mu$ s and the filter must be placed as close as possible to CIN pin.
- The  $\overline{SD}$  is an input/output pin (open-drain type if it is used as output). The CSD capacitor of the filter on  $\overline{SD}$  should be fixed no higher than 3.3 nF in order to ensure the  $\overline{SD}$  activation time  $\tau_1 \leq 500$  ns; the filter should be placed as close as possible to the  $\overline{SD}$  pin.
- The decoupling capacitor  $C_3$  (from 100 to 220 nF, ceramic with low ESR and low ESL), in parallel with each  $C_{boot}$ , filters the high frequency disturbance. Both  $C_{boot}$  and  $C_3$  (if present) should be placed as close as possible to the U, V, W and  $V_{boot}$  pins. Bootstrap negative electrodes should be connected to U, V, W terminals directly and separated from the main output wires.
- To prevent the overvoltage on  $V_{CC}$  pin, a Zener diode (Dz1) can be used. Similarly on the  $V_{boot}$  pin, a Zener diode (Dz2) can be placed in parallel with each  $C_{boot}$ .
- The use of the decoupling capacitor  $C_4$  (100 to 220 nF, with low ESR and low ESL), in parallel with the electrolytic capacitor  $C_{vdc}$  prevents surge destruction. Both capacitors  $C_4$  and  $C_{vdc}$  should be placed as close as possible to the IPM ( $C_4$  has priority over  $C_{vdc}$ ).
- By integrating an application-specific type HVIC inside the module, direct coupling to the MCU terminals without an optocoupler is possible.
- Low inductance shunt resistors should be used for phase leg current sensing.
- In order to avoid malfunctions, the wiring on N pins, the shunt resistor and PWR\_GND should be as short as possible.
- The connection of SGN\_GND to PWR\_GND on one point only (close to the shunt resistor terminal) can help to reduce the impact of power ground fluctuation.

These guidelines ensure the device specifications for application designs. For further details, please refer to the relevant application note.

**Table 15: Recommended operating conditions**

Symbol	Parameter	Test conditions	Min.	Typ.	Max.	Unit
$V_{PN}$	Supply voltage	Applied among P-Nu, Nv, Nw		300	400	V
$V_{CC}$	Control supply voltage	Applied to $V_{CC}$ -GND	13.5	15	18	V
$V_{BS}$	High-side bias voltage	Applied to $V_{BOOTi}$ - $OUT_i$ for $i = U, V, W$	13		18	V
$t_{dead}$	Blanking time to prevent arm-short	For each input signal	1			$\mu$ s
$f_{PWM}$	PWM input signal	-40 $^{\circ}$ C < $T_c$ < 100 $^{\circ}$ C -40 $^{\circ}$ C < $T_j$ < 125 $^{\circ}$ C			25	kHz
$T_c$	Case operation temperature				100	$^{\circ}$ C



## 6 Package information

In order to meet environmental requirements, ST offers these devices in different grades of ECOPACK® packages, depending on their level of environmental compliance. ECOPACK® specifications, grade definitions and product status are available at: [www.st.com](http://www.st.com). ECOPACK® is an ST trademark.

### 6.1 NSDIP-26L package information

Figure 10: NSDIP-26L package outline

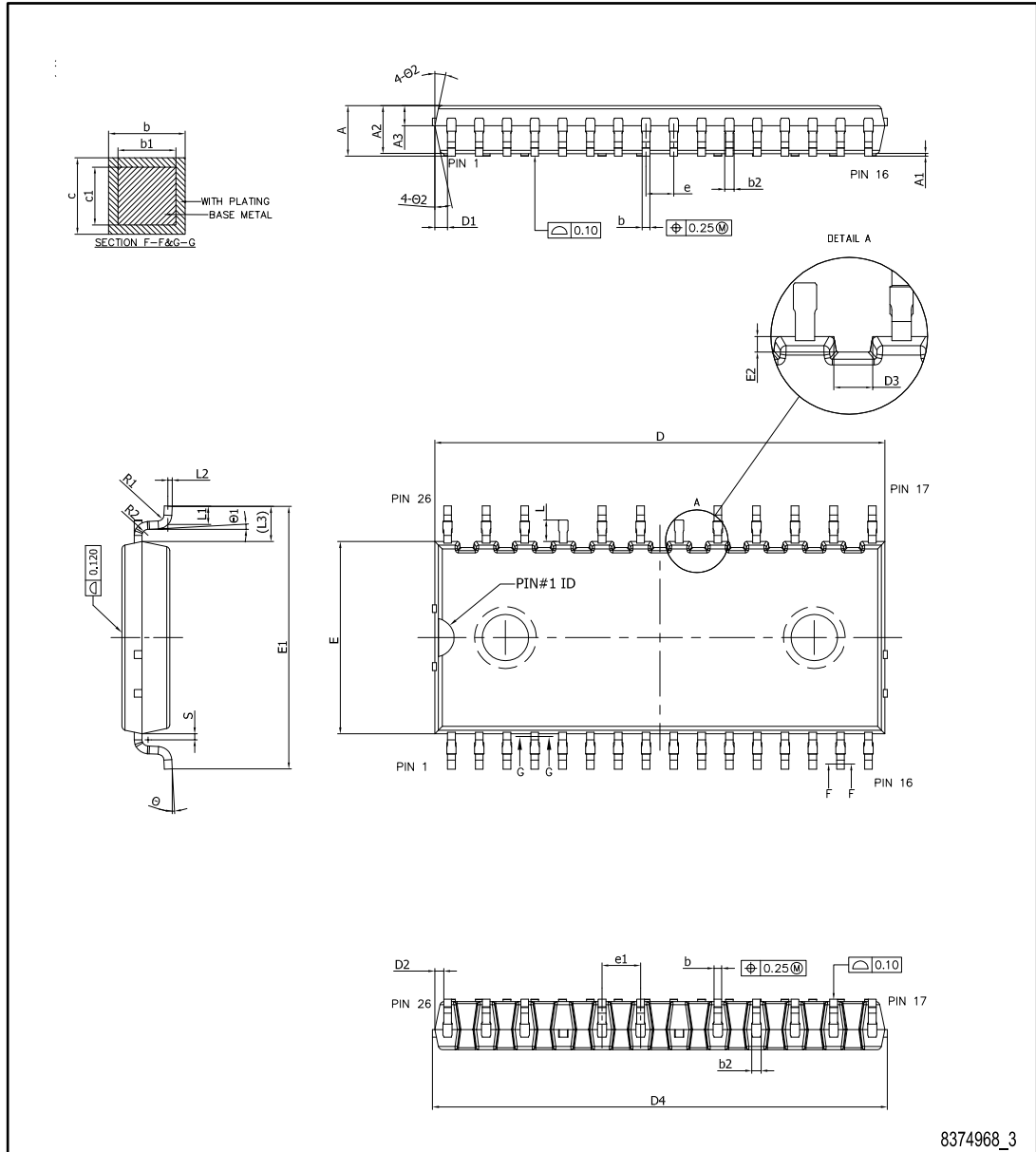
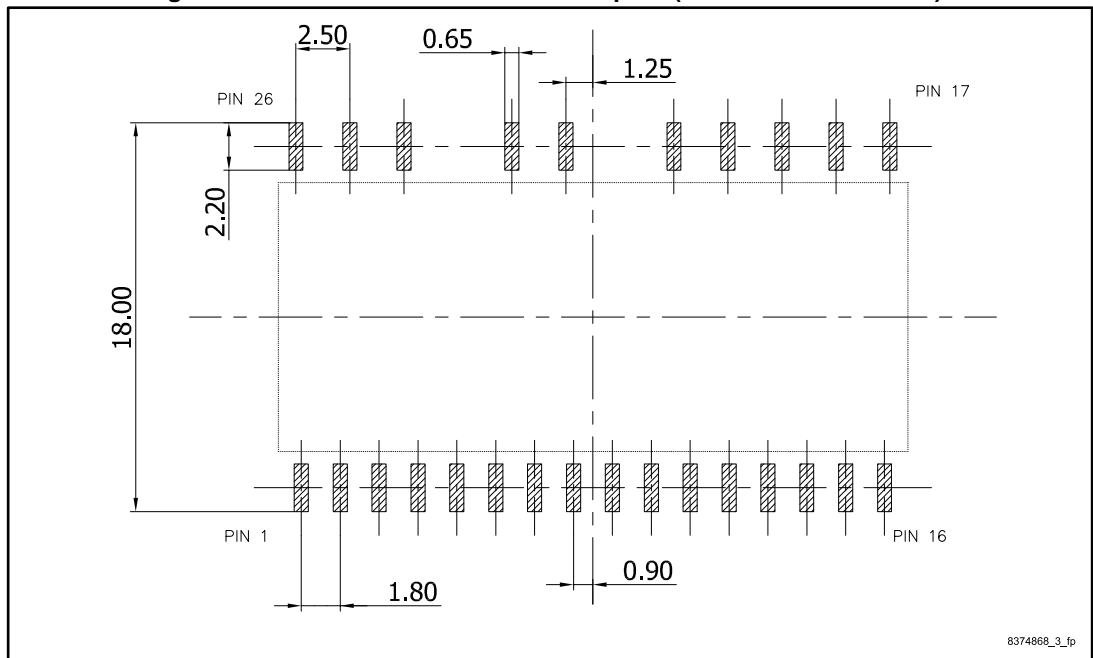

Table 16: NSDIP-26L package mechanical data

Dim.	mm		
	Min.	Typ.	Max.
A			3.45
A1	0.10		0.25
A2	3.00	3.10	3.20
A3	1.70	1.80	1.90
b	0.47		0.57
b1	0.45	0.50	0.55
b2	0.63		0.67
c	0.47		0.57
c1	0.45	0.50	0.55
D	29.05	29.15	29.25
D1	0.70		
D2	0.45		
D3	0.90		
D4			29.65
E	12.35	12.45	12.55
E1	16.70	17.00	17.30
E2	0.35		
e	1.70	1.80	1.90
e1	2.40	2.50	2.60
L	1.24	1.39	1.54
L1	1.00	1.15	1.30
L2	0.25 BSC		
L3	2.275 REF		
R1	0.25	0.40	0.55
R2	0.25	0.40	0.55
S		0.39	0.55
θ	0°		8°
θ1	3° BSC		
θ2	10°	12°	14°

Figure 11: NSDIP-26L recommended footprint (dimensions are in mm)



8374868\_3\_fp

## 7 Revision history

Table 17: Document revision history

Date	Revision	Changes
02-Nov-2017	1	Initial release.
08-Jan-2018	2	Document status promoted from preliminary to production data

**IMPORTANT NOTICE – PLEASE READ CAREFULLY**

STMicroelectronics NV and its subsidiaries ("ST") reserve the right to make changes, corrections, enhancements, modifications, and improvements to ST products and/or to this document at any time without notice. Purchasers should obtain the latest relevant information on ST products before placing orders. ST products are sold pursuant to ST's terms and conditions of sale in place at the time of order acknowledgement.

Purchasers are solely responsible for the choice, selection, and use of ST products and ST assumes no liability for application assistance or the design of Purchasers' products.

No license, express or implied, to any intellectual property right is granted by ST herein.

Resale of ST products with provisions different from the information set forth herein shall void any warranty granted by ST for such product.

ST and the ST logo are trademarks of ST. All other product or service names are the property of their respective owners.

Information in this document supersedes and replaces information previously supplied in any prior versions of this document.

© 2018 STMicroelectronics – All rights reserved



## Стандарт Электрон Связь

Мы молодая и активно развивающаяся компания в области поставок электронных компонентов. Мы поставляем электронные компоненты отечественного и импортного производства напрямую от производителей и с крупнейших складов мира.

Благодаря сотрудничеству с мировыми поставщиками мы осуществляем комплексные и плановые поставки широчайшего спектра электронных компонентов.

Собственная эффективная логистика и склад в обеспечивает надежную поставку продукции в точно указанные сроки по всей России.

Мы осуществляем техническую поддержку нашим клиентам и предпродажную проверку качества продукции. На все поставляемые продукты мы предоставляем гарантию .

Осуществляем поставки продукции под контролем ВП МО РФ на предприятия военно-промышленного комплекса России , а также работаем в рамках 275 ФЗ с открытием отдельных счетов в уполномоченном банке. Система менеджмента качества компании соответствует требованиям ГОСТ ISO 9001.

Минимальные сроки поставки, гибкие цены, неограниченный ассортимент и индивидуальный подход к клиентам являются основой для выстраивания долгосрочного и эффективного сотрудничества с предприятиями радиоэлектронной промышленности, предприятиями ВПК и научно-исследовательскими институтами России.

С нами вы становитесь еще успешнее!

### Наши контакты:

**Телефон:** +7 812 627 14 35

**Электронная почта:** [sales@st-electron.ru](mailto:sales@st-electron.ru)

**Адрес:** 198099, Санкт-Петербург,  
Промышленная ул, дом № 19, литера Н,  
помещение 100-Н Офис 331