



MICROCHIP

**EVB-LAN9252-PICtail™
Add-On Board
User's Guide**

Note the following details of the code protection feature on Microchip devices:

- Microchip products meet the specification contained in their particular Microchip Data Sheet.
- Microchip believes that its family of products is one of the most secure families of its kind on the market today, when used in the intended manner and under normal conditions.
- There are dishonest and possibly illegal methods used to breach the code protection feature. All of these methods, to our knowledge, require using the Microchip products in a manner outside the operating specifications contained in Microchip's Data Sheets. Most likely, the person doing so is engaged in theft of intellectual property.
- Microchip is willing to work with the customer who is concerned about the integrity of their code.
- Neither Microchip nor any other semiconductor manufacturer can guarantee the security of their code. Code protection does not mean that we are guaranteeing the product as "unbreakable."

Code protection is constantly evolving. We at Microchip are committed to continuously improving the code protection features of our products. Attempts to break Microchip's code protection feature may be a violation of the Digital Millennium Copyright Act. If such acts allow unauthorized access to your software or other copyrighted work, you may have a right to sue for relief under that Act.

Information contained in this publication regarding device applications and the like is provided only for your convenience and may be superseded by updates. It is your responsibility to ensure that your application meets with your specifications. MICROCHIP MAKES NO REPRESENTATIONS OR WARRANTIES OF ANY KIND WHETHER EXPRESS OR IMPLIED, WRITTEN OR ORAL, STATUTORY OR OTHERWISE, RELATED TO THE INFORMATION, INCLUDING BUT NOT LIMITED TO ITS CONDITION, QUALITY, PERFORMANCE, MERCHANTABILITY OR FITNESS FOR PURPOSE. Microchip disclaims all liability arising from this information and its use. Use of Microchip devices in life support and/or safety applications is entirely at the buyer's risk, and the buyer agrees to defend, indemnify and hold harmless Microchip from any and all damages, claims, suits, or expenses resulting from such use. No licenses are conveyed, implicitly or otherwise, under any Microchip intellectual property rights unless otherwise stated.

Trademarks

The Microchip name and logo, the Microchip logo, dsPIC, FlashFlex, flexPWR, JukeBlox, KEELOQ, KEELOQ logo, Kleer, LANCheck, MediaLB, MOST, MOST logo, MPLAB, OptoLyzer, PIC, PICSTART, PIC³² logo, RightTouch, SpyNIC, SST, SST Logo, SuperFlash and UNI/O are registered trademarks of Microchip Technology Incorporated in the U.S.A. and other countries.

The Embedded Control Solutions Company and mTouch are registered trademarks of Microchip Technology Incorporated in the U.S.A.

Analog-for-the-Digital Age, BodyCom, chipKIT, chipKIT logo, CodeGuard, dsPICDEM, dsPICDEM.net, ECAN, In-Circuit Serial Programming, ICSP, Inter-Chip Connectivity, KleerNet, KleerNet logo, MiWi, motorBench, MPASM, MPF, MPLAB Certified logo, MPLIB, MPLINK, MultiTRAK, NetDetach, Omniscient Code Generation, PICDEM, PICDEM.net, PICkit, PICtail, RightTouch logo, REAL ICE, SQI, Serial Quad I/O, Total Endurance, TSHARC, USBCheck, VariSense, ViewSpan, WiperLock, Wireless DNA, and ZENA are trademarks of Microchip Technology Incorporated in the U.S.A. and other countries.

SQTP is a service mark of Microchip Technology Incorporated in the U.S.A.

Silicon Storage Technology is a registered trademark of Microchip Technology Inc. in other countries.

GestIC is a registered trademark of Microchip Technology Germany II GmbH & Co. KG, a subsidiary of Microchip Technology Inc., in other countries.

All other trademarks mentioned herein are property of their respective companies.

© 2015, Microchip Technology Incorporated, Printed in the U.S.A., All Rights Reserved.

ISBN: 978-1-63277-928-1

**QUALITY MANAGEMENT SYSTEM
CERTIFIED BY DNV
= ISO/TS 16949 =**

Microchip received ISO/TS-16949:2009 certification for its worldwide headquarters, design and wafer fabrication facilities in Chandler and Tempe, Arizona; Gresham, Oregon and design centers in California and India. The Company's quality system processes and procedures are for its PIC® MCUs and dsPIC® DSCs, KEELOQ® code hopping devices, Serial EEPROMs, microperipherals, nonvolatile memory and analog products. In addition, Microchip's quality system for the design and manufacture of development systems is ISO 9001:2000 certified.

Object of Declaration: EVB-LAN9252-PICtail Add-On Board

EU Declaration of Conformity

Manufacturer: Microchip Technology Inc.
2355 W. Chandler Blvd.
Chandler, Arizona, 85224-6199
USA

This declaration of conformity is issued by the manufacturer.

The development/evaluation tool is designed to be used for research and development in a laboratory environment. This development/evaluation tool is not a Finished Appliance, nor is it intended for incorporation into Finished Appliances that are made commercially available as single functional units to end users under EU EMC Directive 2004/108/EC and as supported by the European Commission's Guide for the EMC Directive 2004/108/EC (8th February 2010).

This development/evaluation tool complies with EU RoHS2 Directive 2011/65/EU.

This development/evaluation tool, when incorporating wireless and radio-telecom functionality, is in compliance with the essential requirement and other relevant provisions of the R&TTE Directive 1999/5/EC and the FCC rules as stated in the declaration of conformity provided in the module datasheet and the module product page available at www.microchip.com.

For information regarding the exclusive, limited warranties applicable to Microchip products, please see Microchip's standard terms and conditions of sale, which are printed on our sales documentation and available at www.microchip.com.

Signed for and on behalf of Microchip Technology Inc. at Chandler, Arizona, USA

Derek Carlson
VP Development Tools

12-Sep-14
Date

NOTES:

Table of Contents

Preface	7
Introduction.....	7
Document Layout	7
Conventions Used in this Guide	8
The Microchip Web Site	9
Development Systems Customer Change Notification Service	9
Customer Support	9
Document Revision History	10
Chapter 1. Overview	
1.1 Introduction	11
1.2 References	12
1.3 Terms and Abbreviations	12
Chapter 2. Board Details	
2.1 Power	14
2.2 PICtail™ Plus Interface	14
2.3 Clock	15
Chapter 3. Board Configuration	
3.1 Straps and LEDs	17
3.1.1 Chip Mode	17
3.1.2 EEPROM Size Configuration	17
3.1.3 LEDs	17
3.2 Process Data Interface	17
3.2.1 IRQ Selection	18
3.2.2 HBI Mode	18
3.2.3 SPI/SQI Mode	19
Appendix A. EVB-LAN9252-PICtail Add-On Board	
A.1 Introduction	21
Appendix B. Schematics	
B.1 Introduction	23
Appendix C. Bill of Materials (BOM)	
C.1 Introduction	27
Worldwide Sales and Service	30

NOTES:

Preface

NOTICE TO CUSTOMERS

All documentation becomes dated, and this manual is no exception. Microchip tools and documentation are constantly evolving to meet customer needs, so some actual dialogs and/or tool descriptions may differ from those in this document. Please refer to our web site (www.microchip.com) to obtain the latest documentation available.

Documents are identified with a “DS” number. This number is located on the bottom of each page, in front of the page number. The numbering convention for the DS number is “DSXXXXA”, where “XXXX” is the document number and “A” is the revision level of the document.

For the most up-to-date information on development tools, see the MPLAB® IDE online help. Select the Help menu, and then Topics to open a list of available online help files.

INTRODUCTION

This chapter contains general information that will be useful to know before using the EVB-LAN9252-PICtail Add-On Board. Items discussed in this chapter include:

- [Document Layout](#)
- [Conventions Used in this Guide](#)
- [The Microchip Web Site](#)
- [Development Systems Customer Change Notification Service](#)
- [Customer Support](#)
- [Document Revision History](#)

DOCUMENT LAYOUT

This document describes how to use the EVB-LAN9252-PICtail Add-On Board as a development tool for the LAN9252 and its connectivity to the Explorer 16 development platform. The manual layout is as follows:

- **Chapter 1. “Overview”** – Shows a brief description of the EVB-LAN9252-PICtail Add-On Board.
- **Chapter 2. “Board Details”** – Describes the various board features of the EVB-LAN9252-PICtail Add-On Board, including jumpers, LEDs, test points, system connections, and switches.
- **Chapter 3. “Board Configuration”** – Provides information about the EVB-LAN9252-PICtail Add-On Board configuration.
- **Appendix A. “EVB-LAN9252-PICtail Add-On Board”** – This appendix shows the EVB-LAN9252-PICtail Add-On Board.
- **Appendix B. “Schematics”** – This appendix shows the EVB-LAN9252-PICtail Add-On Board schematics.
- **Appendix C. “Bill of Materials (BOM)”** – This appendix includes the EVB-LAN9252-PICtail Add-On Board Bill of Materials (BOM).

CONVENTIONS USED IN THIS GUIDE

This manual uses the following documentation conventions:

DOCUMENTATION CONVENTIONS

Description	Represents	Examples
Arial font:		
Italic characters	Referenced books	<i>MPLAB® IDE User's Guide</i>
	Emphasized text	...is the <i>only</i> compiler...
Initial caps	A window	the Output window
	A dialog	the Settings dialog
	A menu selection	select Enable Programmer
Quotes	A field name in a window or dialog	"Save project before build"
Underlined, italic text with right angle bracket	A menu path	<u>File>Save</u>
Bold characters	A dialog button	Click OK
	A tab	Click the Power tab
N'Rnnnn	A number in verilog format, where N is the total number of digits, R is the radix and n is a digit.	4'b0010, 2'hF1
Text in angle brackets < >	A key on the keyboard	Press <Enter>, <F1>
Courier New font:		
Plain Courier New	Sample source code	#define START
	Filenames	autoexec.bat
	File paths	c:\mcc18\h
	Keywords	_asm, _endasm, static
	Command-line options	-Opa+, -Opa-
	Bit values	0, 1
	Constants	0xFF, 'A'
Italic Courier New	A variable argument	<i>file.o</i> , where <i>file</i> can be any valid filename
Square brackets []	Optional arguments	mcc18 [options] <i>file</i> [options]
Curly brackets and pipe character: { }	Choice of mutually exclusive arguments; an OR selection	errorlevel {0 1}
Ellipses...	Replaces repeated text	var_name [, var_name...]
	Represents code supplied by user	void main (void) { ... }

THE MICROCHIP WEB SITE

Microchip provides online support via our web site at www.microchip.com. This web site is used as a means to make files and information easily available to customers. Accessible by using your favorite Internet browser, the web site contains the following information:

- **Product Support** – Data sheets and errata, application notes and sample programs, design resources, user's guides and hardware support documents, latest software releases and archived software
- **General Technical Support** – Frequently Asked Questions (FAQs), technical support requests, online discussion groups, Microchip consultant program member listing
- **Business of Microchip** – Product selector and ordering guides, latest Microchip press releases, listing of seminars and events, listings of Microchip sales offices, distributors and factory representatives

DEVELOPMENT SYSTEMS CUSTOMER CHANGE NOTIFICATION SERVICE

Microchip's customer notification service helps keep customers current on Microchip products. Subscribers will receive e-mail notification whenever there are changes, updates, revisions or errata related to a specified product family or development tool of interest.

To register, access the Microchip web site at www.microchip.com, click on Customer Change Notification and follow the registration instructions.

The Development Systems product group categories are:

- **Compilers** – The latest information on Microchip C compilers, assemblers, linkers and other language tools. These include all MPLAB C compilers; all MPLAB assemblers (including MPASM assembler); all MPLAB linkers (including MPLINK object linker); and all MPLAB librarians (including MPLIB object librarian).
- **Emulators** – The latest information on Microchip in-circuit emulators. This includes the MPLAB REAL ICE and MPLAB ICE 2000 in-circuit emulators.
- **In-Circuit Debuggers** – The latest information on the Microchip in-circuit debuggers. This includes MPLAB ICD 3 in-circuit debuggers and PICkit 3 debug express.
- **MPLAB IDE** – The latest information on Microchip MPLAB IDE, the Windows Integrated Development Environment for development systems tools. This list is focused on the MPLAB IDE, MPLAB IDE Project Manager, MPLAB Editor and MPLAB SIM simulator, as well as general editing and debugging features.
- **Programmers** – The latest information on Microchip programmers. These include production programmers such as MPLAB REAL ICE in-circuit emulator, MPLAB ICD 3 in-circuit debugger and MPLAB PM3 device programmers. Also included are nonproduction development programmers such as PICSTART Plus and PIC-kit 2 and 3.

CUSTOMER SUPPORT

Users of Microchip products can receive assistance through several channels:

- Distributor or Representative
- Local Sales Office
- Field Application Engineer (FAE)
- Technical Support

EVB-LAN9252-PICtail Add-On Board User's Guide

Customers should contact their distributor, representative or field application engineer (FAE) for support. Local sales offices are also available to help customers. A listing of sales offices and locations is included in the back of this document.

Technical support is available through the web site at:

<http://www.microchip.com/support>

DOCUMENT REVISION HISTORY

Revision A (November 2015)

- Initial Release of this Document.

Chapter 1. Overview

1.1 INTRODUCTION

EVB-LAN9252-PICTail™ Add-On Board is used for evaluating Microchip Technology's LAN9252, a 2/3-port EtherCAT® slave controller with dual integrated Ethernet PHYs. It is an expansion board compatible with Explorer 16 development platform.

This document details the EVB-LAN9252-PICTail Add-On Board features and its connectivity to the Explorer 16 development platform. This EVB currently supports 3 plug-in modules (PIMs), namely [MA320003 (PIC32MX795F512L), MA240011 (PIC24FJ128GA010), and MA320012 (PIC32MZxxxxECx100)], on this platform.

Figure 1-1 shows the block diagram.

FIGURE 1-1: EVB-LAN9252-PICTAIL ADD-ON BOARD BLOCK DIAGRAM

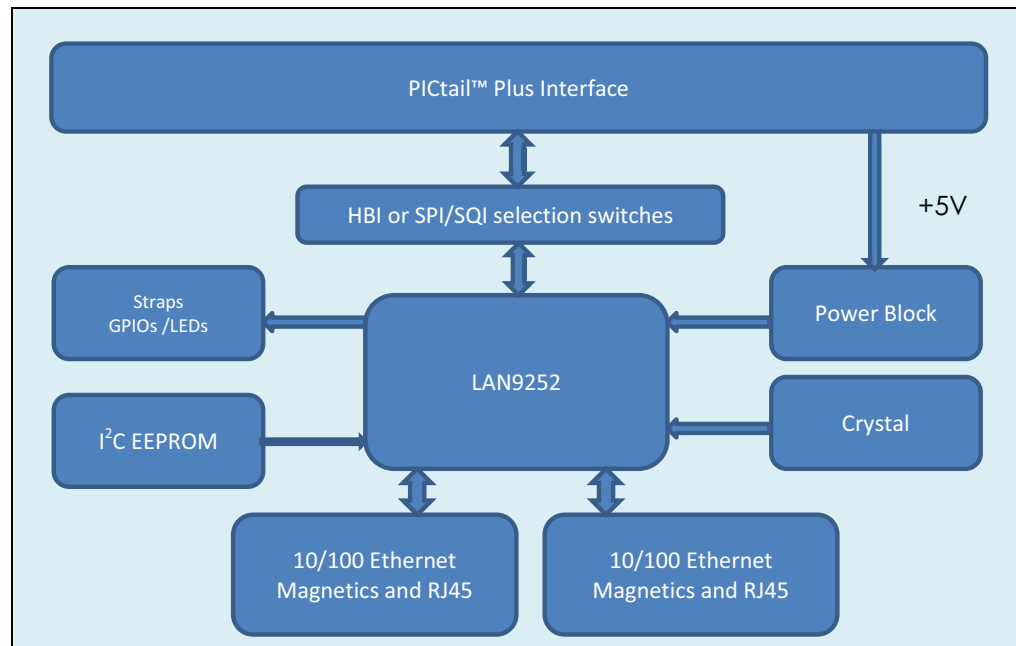

1.2 REFERENCES

Concepts and material available in the following documents may be helpful when reading this document. Visit www.microchip.com for the latest documentation.

Document	Location
LAN9252 Datasheet	Visit www.microchip.com .
AN8-13 Suggested Magnetics	http://www.microchip.com/wwwAppNotes/AppNotes.aspx?appnote=en562793
EVB-LAN9252-PICtail Add-On Board Schematic	Visit www.microchip.com .

1.3 TERMS AND ABBREVIATIONS

- EVB - Evaluation Board
- DNP - Do Not Populate
- 100BASE-TX- 100 Mbps Fast Ethernet, IEEE 802.3u Compliant
- GPIO - General Purpose I/O
- HBI - Host Bus Interface
- SPI - Serial Peripheral Interface
- SQI - Serial Quad Interface
- PIM - Plug-in Module

Chapter 2. Board Details

The following sections describe the various board features, including jumpers, LEDs, test points, system connections, and switches. A top view of the EVB-LAN9252-PICtail Add-On Board is shown in [Figure 2-1](#).

FIGURE 2-1: EVB-LAN9252-PICTAIL ADD-ON BOARD

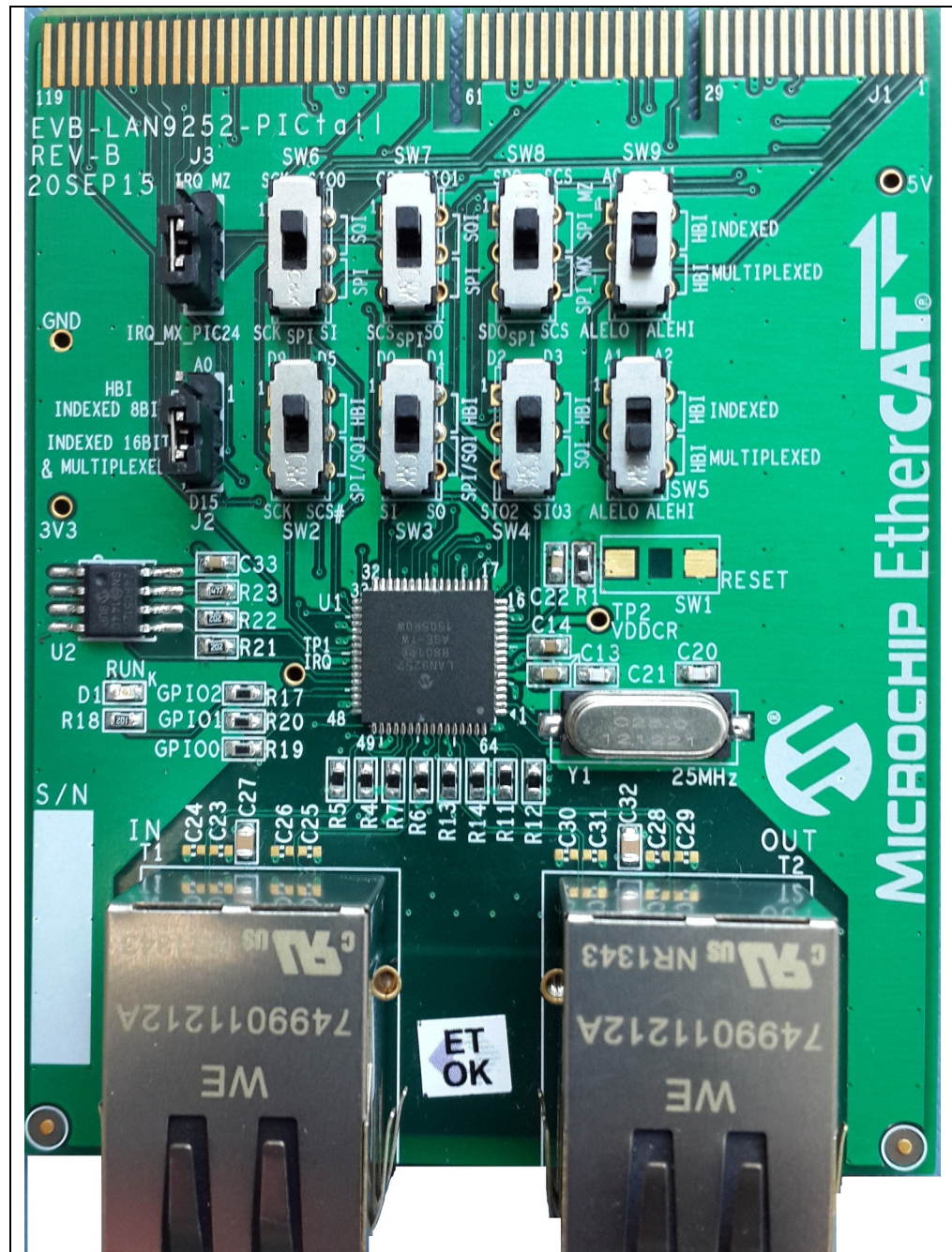

2.1 POWER

Power is supplied as +5V and +3.3V to the board via the PICtail™ Plus interface from the Explorer 16 Development Board. LAN9252 has an internal 1.2 V regulator which supplies power to the internal core logic.

2.2 PICTAIL™ PLUS INTERFACE

Plug the EVB-LAN9252-PICtail Add-On Board J1 edge connector into the topmost position of the J5 slot on the Explorer 16 Board, as shown in [Figure 2-2](#).

FIGURE 2-2: EVB-LAN9252-PICTAIL ADD-ON BOARD WITH EXPLORER 16 DEVELOPMENT BOARD

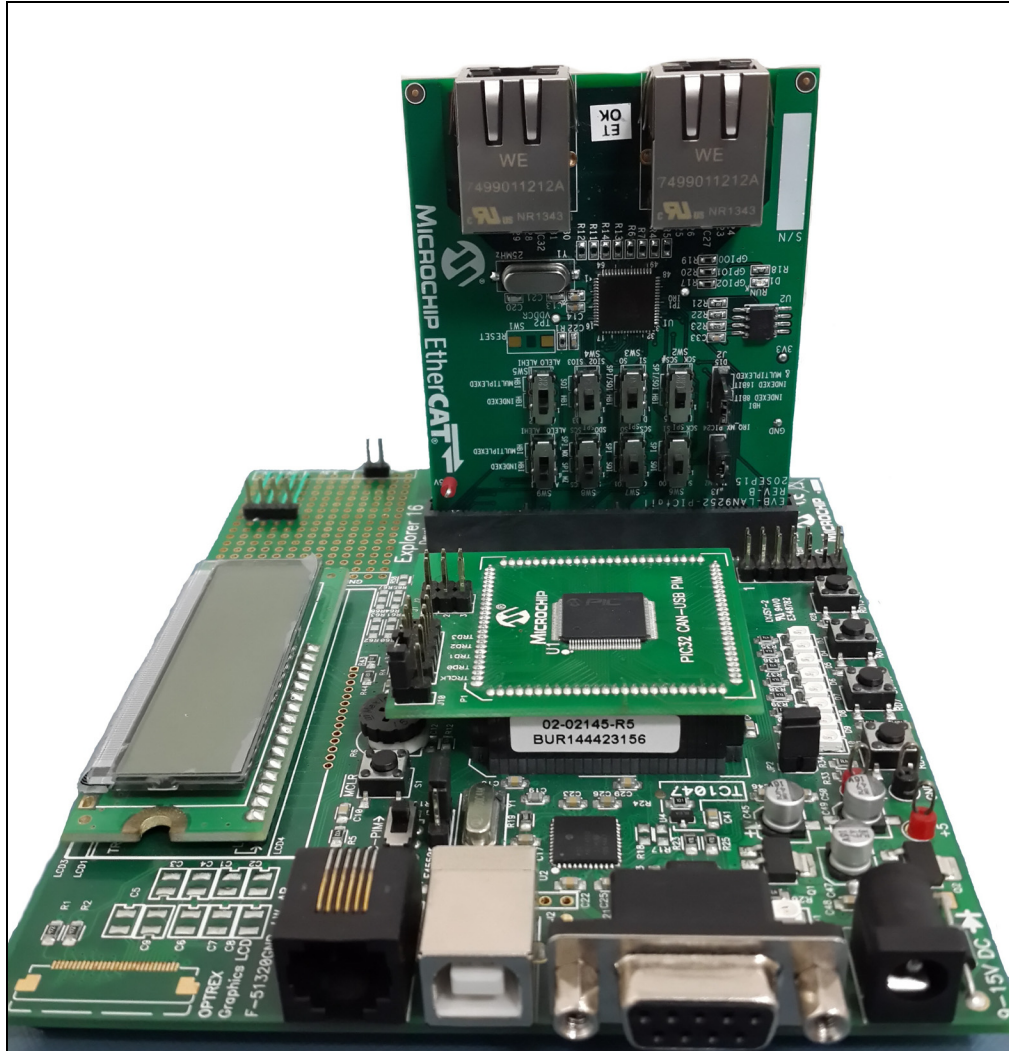

The pin details of the connector J1 of EVB-LAN9252-PICtail Add-On Board are enumerated in [Table 2-1](#).

TABLE 2-1: J1 CONNECTOR PIN DETAILS

Pin Number	Signal	Pin Number	Signal	Pin Number	Signal
1	MX_SCS	4	NC	7	SDI
2	NC	5	MX_SDO	8	NC
3	SCK	6	NC	9	GND

TABLE 2-1: J1 CONNECTOR PIN DETAILS (CONTINUED)

Pin Number	Signal	Pin Number	Signal	Pin Number	Signal
10	GND	47	GND	86	NC
11	NC	48	GND	87	NC
12	NC	49	IRQ_MX- _PIC24	88	NC
13	NC	50	NC	89	NC
14	NC	51	NC	90	NC
15	NC	52	NC	91	NC
16	NC	53	3V3	92	NC
17	SYNC1/LATC H1	54	3V3	93	SQI_D0
18	SYNC0/LATC H0	55	5V	94	NC
19	NC	56	5V	95	NC
20	NC	57	NC	96	NC
21	3V3	58	NC	97	WR/ENB
22	3V3	59	NC	98	RD/RD_WR
23	5V	60	D8	99	D14
24	5V	61	NC	100	D15
25	NC	62	D9	101	NC
26	NC	65	NC	102	SQI_CS0
27	NC	66	SQI_D2	103	CS
28	D11	67	SQI_D1	104	NC
29	NC	68	NC	105	D12
30	D10	69	NC	106	D13
31	NC	70	NC	107	3V3
32	NC	71	NC	108	3V3
33	A2	72	NC	109	D0
34	NC	73	SQI_SCK	110	D1
35	NC	74	SQI_D3	111	D2
36	IRQ_MZ	75	NC	112	D3
37	A4	76	NC	113	D4
38	NC	77	NC	114	D5
39	A3	78	NC	115	D6
40	NC	79	MZ_SDO	116	D7
41	GND	80	NC	117	NC
42	GND	81	NC	118	NC
43	NC	82	MZ_SCS	119	GND
44	NC	83	ALEHI_A1_J5	120	GND
45	NC	84	ALELO_A0_J 5		
46	NC	85	NC		

2.3 CLOCK

The LAN9252 requires a fixed-frequency 25 MHz clock source for use by the internal clock oscillator and phase-locked loop (PLL). This is typically provided by attaching a 25 MHz crystal to the OSCI and OSCO pins.

NOTES:

Chapter 3. Board Configuration

3.1 STRAPS AND LEADS

The following tables describe the default settings and jumper descriptions for the EVB-LAN9252-PICtail Add-On Board. These defaults are the recommended configurations for evaluation of the LAN9252. These settings may be changed as needed, however, any deviation from the defaults settings should be approached with care and knowledge of the schematics and datasheet. An incorrect jumper setting may disable the board.

3.1.1 Chip Mode

By default, EVB-LAN9252-PICtail Add-On Board supports only the 2-port mode (CHIP_MODE0 and CHIP_MODE1 signals pulled down).

3.1.2 EEPROM Size Configuration

By default, the EEPROM size in this EVB-LAN9252-PICtail Add-On Board is 512k.

3.1.3 LEDs

D1 LED is used as a RUN indicator (green) to show the AL status of the EtherCAT State Machine (ESM), as detailed in [Table 3-1](#).

TABLE 3-1: D1 RUN LED STATUS INDICATOR

State	Description
Off	The device is in the INITIALIZATION state
Blinking (on 200ms, off 200ms)	The device is in the PRE-OPERATIONAL state
Single Flash (on 200ms, off 1000ms)	The device is in the SAFE-OPERATIONAL state
On	The device is in the OPERATIONAL state
Flickering (on 50ms, off 50ms)	The device is booting and has not yet entered the INITIALIZATION state, or the device is in the BOOTSTRAP state and firmware download is in progress. (Optional. Off when not implemented.)

3.2 PROCESS DATA INTERFACE

The Process Data Interface (PDI) is used to communicate with external system-on-chip (SoC). The EVB-LAN9252-PICtail Add-On Board supports three different PDI configurations:

- HBI (8-bit mode only)
- SPI (default)
- SQI [supported only with MA320003 (PIC32MX795F512L)]

The following sections detail the hardware configurations required for the EVB-LAN9252-PICtail Add-On Board for all three PDI options.

3.2.1 IRQ Selection

Based on the PIMs on the Explorer 16 Development Board [MA320003 (PIC32MX-795F512L), MA240011 (PIC24FJ128GA010) or with MA320012 (PIC32MZxxxx-ECx100)] the following configuration in [Table 3-2](#) has to be done in J3 for Interrupt Request (IRQ) signal.

TABLE 3-2: IRQ SELECTION

Short Pins (J3)	Plug-In Board with Explorer 16 Development Board
2-3	MA320003 (PIC32MX795F512L) MA240011 (PIC24FJ128GA010)
1-2	MA320012 (PIC32MZxxxxECx100)

3.2.2 HBI Mode

The Host Bus Interface (HBI) module provides a high-speed asynchronous slave interface that facilitates communication between LAN9252 and the host system. The HBI allows access to the System CSRs and the internal FIFOs and memories, and also handles byte swapping based on the endianness select.

To select HBI Mode, configuration should be done based on [Table 3-3](#). However, to further configure in indexed or multiplexed mode, refer to the subsections below.

TABLE 3-3: HBI MODE SWITCH CONFIGURATION

Switch	Short Pins
SW2 (D9 and D5)	1-2 & 4-5
SW3 (D0 and D1)	1-2 & 4-5
SW4 (D2 and D3)	1-2 & 4-5

3.2.2.1 HBI MULTIPLEXED MODE CONFIGURATION

In Multiplexed Address/Data mode, the address, FIFO Direct Select and endianness select inputs are shared with the data bus.

To operate in the HBI Multiplexed mode, the following switch configurations in [Table 3-4](#) must be enabled.

TABLE 3-4: HBI MULTIPLEXED MODE SWITCH CONFIGURATION

Switch	Short Pins
SW9 (ALELO)	2-3 & 5-6
SW5 (ALEHI)	2-3 & 5-6

Along with the switch configuration the following jumper configuration in [Table 3-5](#) must be enabled.

TABLE 3-5: HBI MULTIPLEXED MODE JUMPER CONFIGURATION

Jumper	Short Pins
J2 (D15)	2-3

3.2.2.2 HBI INDEXED MODE

In Indexed Address mode, access to the internal registers and memory of the device are indirectly mapped using Index and Data registers.

To operate in the HBI Multiplexed mode, the following switch configurations in [Table 3-6](#) must be enabled.

TABLE 3-6: HBI INDEXED MODE SWITCH CONFIGURATION

Switch	Short Pins
SW9 (A0 and A1)	1-2 & 4-5
SW5 (A2 and A1)	1-2 & 4-5

Along with the switch configuration, the following jumper configuration in [Table 3-7](#) must be done for 8-bit/16-bit mode.

TABLE 3-7: HBI INDEXED MODE JUMPER CONFIGURATION

Jumper	Short Pins	Mode
J2 (D15)	2-3	Indexed 8-bit
J3 (A0)	1-2	Indexed 16-bit

3.2.3 SPI/SQI Mode

The SPI/SQI Slave module provides a low pin count synchronous slave interface that facilitates communication between the device and a host system. The SPI/SQI Slave allows access to the System CSRs and the internal FIFOs and memories. It supports single and multiple register read and write commands with incrementing, decrementing and static addressing. Single-bit lanes are supported in SPI mode.

To select SPI/SQI Mode, configuration should be done as in [Table 3-8](#).

TABLE 3-8: SPI/SQI MODE SWITCH CONFIGURATION

Jumper	Short Pins
SW2 (SPI/SQI_CLK and SCS#)	2-3 & 5-6
SW3 (SI/SIO0 and SO/SIO1)	2-3 & 5-6
SW4 (SQI_D2 and SQI_D3)	2-3 & 5-6

3.2.3.1 SPI MODE CONFIGURATION

The following switches need to be configured as in [Table 3-9](#) to enable the SPI mode to communicate with the Explorer 16 Development Board.

TABLE 3-9: SPI MODE SWITCH CONFIGURATION

Jumper	Short Pins
SW6 (SCK and SDI)	2-3 & 5-6
SW7 (SCS and SO)	2-3 & 5-6

Based on the plug-in boards on the Explorer 16 Development Board, [MA320003 (PIC32MX795F512L), MA240011 (PIC24FJ128GA010) or with MA320012 (PIC32MZxxxxECx100)] the following configuration in [Table 3-10](#) has to be done in SW8.

TABLE 3-10: SPI CONFIGURATION

Short Pins	Plug-In Board with Explorer 16 Development Board
1-2 & 4-5	MA320003 (PIC32MX795F512L) MA240011 (PIC24FJ128GA010)
2-3 & 5-6	MA320012 (PIC32MZxxxxECx100)

3.2.3.2 SQI MODE CONFIGURATION [MA320012 (PIC32MZXXXECX100) ONLY]

The following switches need to be configured to enable the SPI mode to communicate with the Explorer 16 Development Board.

TABLE 3-11: SQI MODE SWITCH CONFIGURATION

Jumper	Short Pins
SW6 (SQI_SCI and SQI_D0)	1-2 & 4-5
SW7 (SQI_CS0 and SQI_D1)	1-2 & 4-5

Appendix A. EVB-LAN9252-PICtail Add-On Board

A.1 INTRODUCTION

This appendix shows the EVB-LAN9252-PICtail Add-On Board.

FIGURE A-1: EVB-LAN9252-PICTAIL ADD-ON BOARD

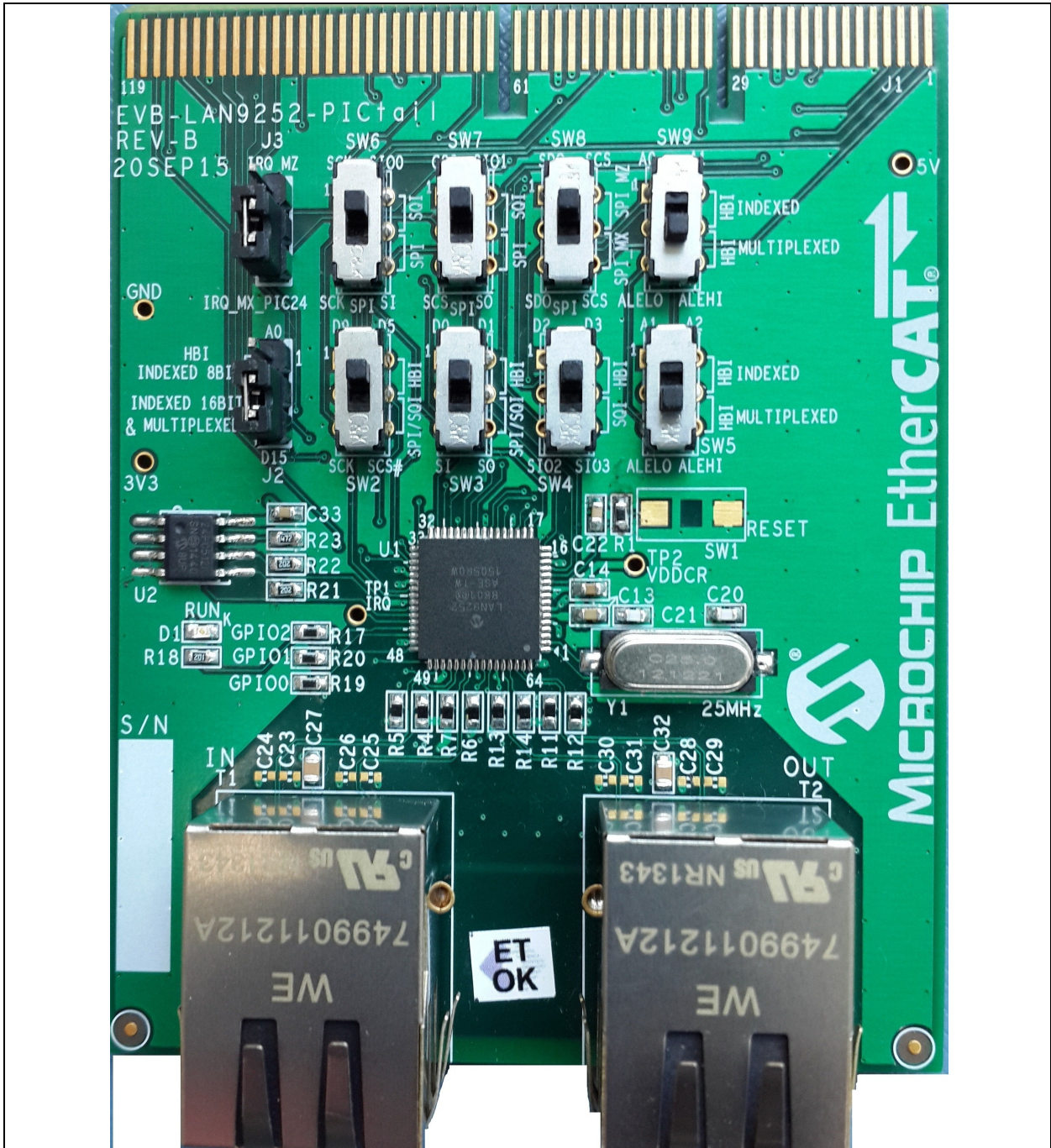

NOTES:



Appendix B. Schematics

B.1 INTRODUCTION

This appendix shows the EVB-LAN9252-PICtail Add-On Board Schematics.

FIGURE B-1: LAN9252

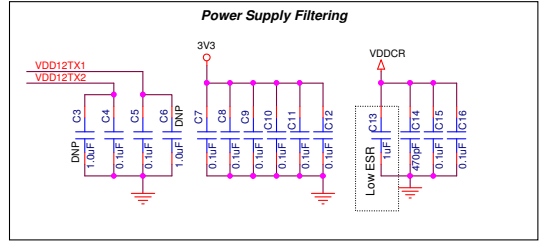
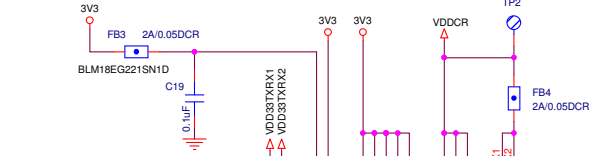
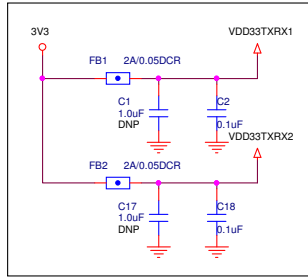

Note:
OSC VSS need to connect to Chip gnd.

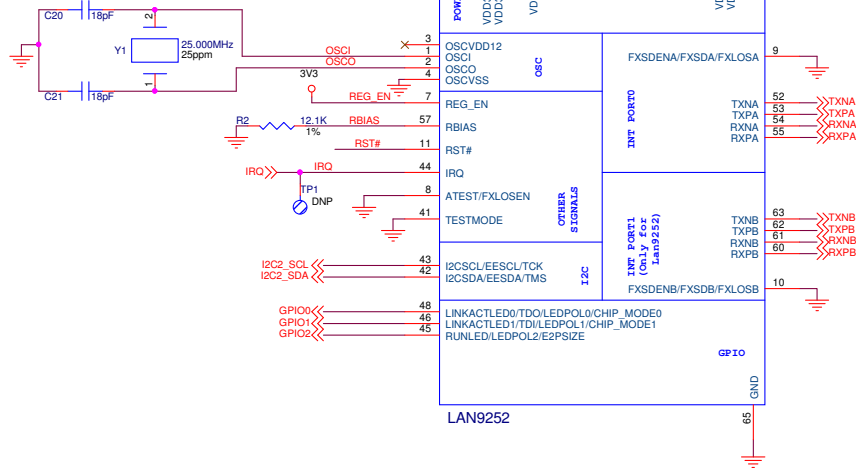
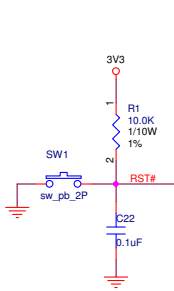
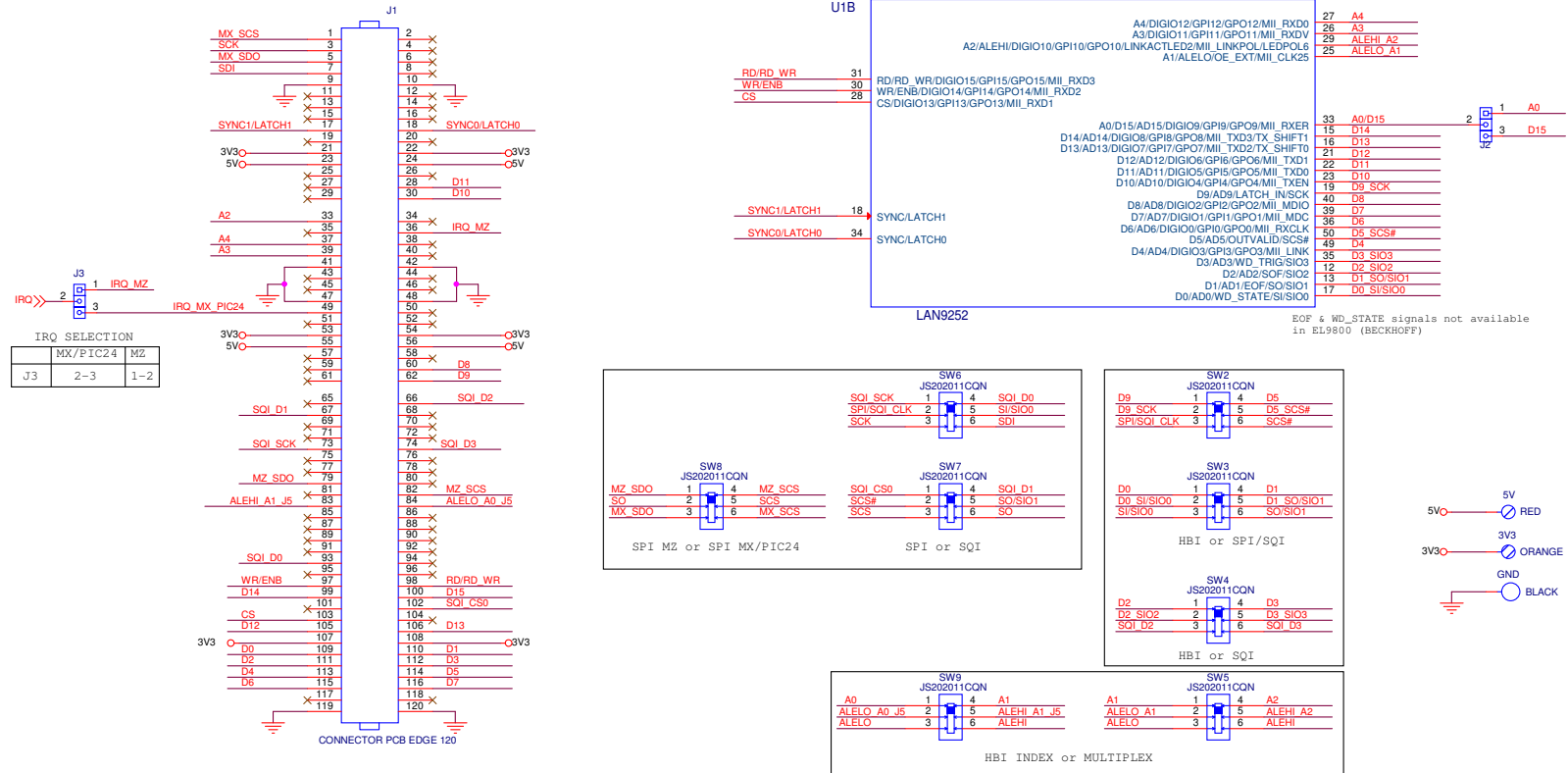

FIGURE B-2: COPPER MODE INTERFACE



	J2	SW2, SW3, SW4	SW5, SW9	SW6 & SW7	SW8
HBI	1-2=A0 2-3=D15	1-2 4-5	1-2 & 4-5 = A0, A1, A2 2-3 & 5-6 = ALELO, ALEHI	NA	NA
SPI	NA	2-3 5-6	NA	2-3 5-6	1-2 & 4-5 = SPI_MZ 2-3 & 5-6 = SPI_MX/PIC24
SQI	NA	2-3 5-6	NA	1-2 4-5	NA

INTERFACE AVAILABILITY DETAILS			
	MX MA320003 PIC32MX795P512L	MZ MA320012 PIC32MZxxxECx100	PIC24 MA240011 PIC24FJ128GA010
HBI	8 BIT & 16 BIT	8 BIT ONLY 16BIT = NA	8 BIT ONLY 16BIT = NA
SPI	YES	YES	YES
SQI	NO	YES	NO

FIGURE B-3: B2B INTERFACE

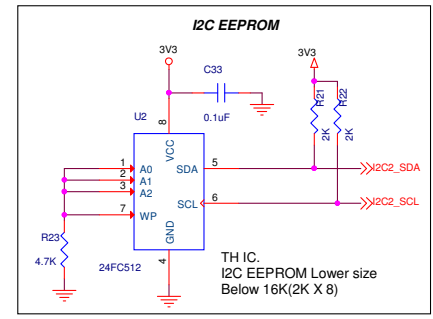
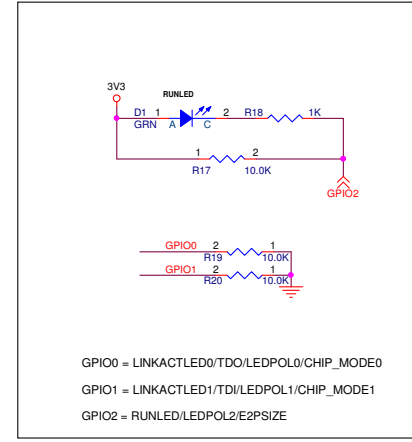
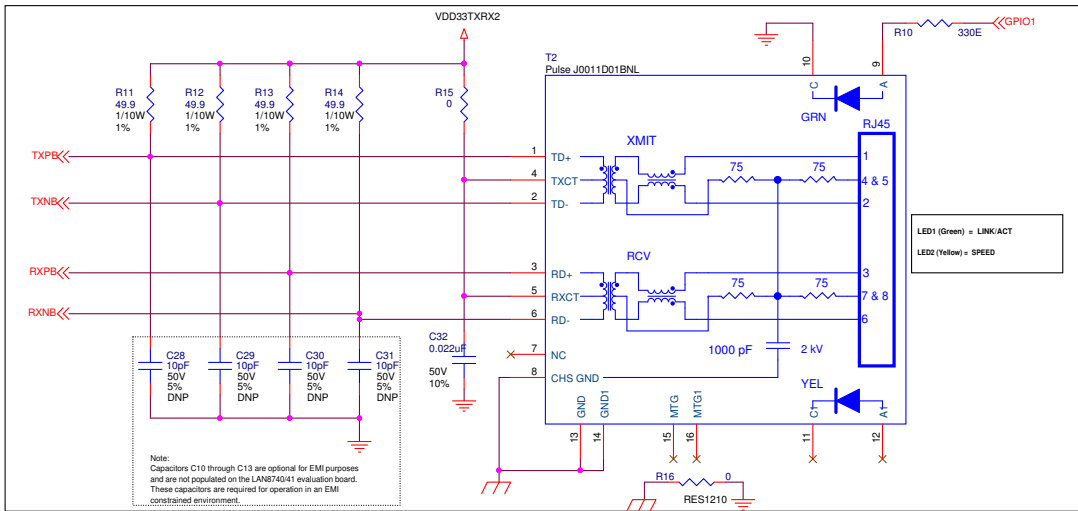
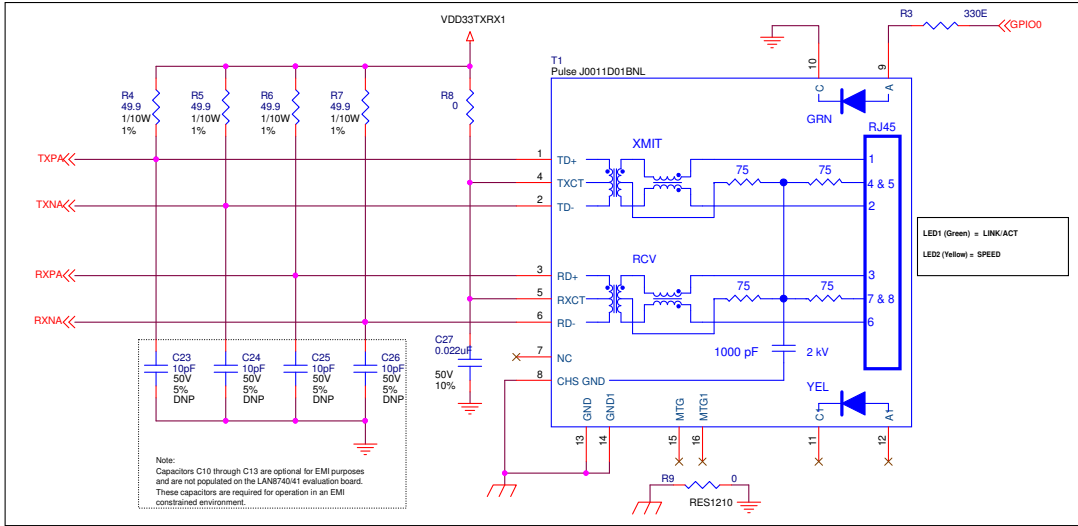



Appendix C. Bill of Materials (BOM)

C.1 INTRODUCTION

This appendix includes the EVB-LAN9252-PICtail Add-On Board Bill of Materials (BOM).

TABLE C-1: EVB-LAN9252-PICTAIL EVALUATION BOARD BILL OF MATERIALS

Item	Qty	Reference	Part	PCB Footprint	DNP	Manufacturer	Manufacturer Part Number
2	15	C2,C4,C5,C7,C8,C9,C10,C11,C12,C15,C16,C18,C19,C22,C33	0.1uF	CAP0603	No	Murata	GRM188R71E104KA01D
3	1	C13	1uF	CAP0603	No	Murata	GRM188R61C105KA93D
4	1	C14	470pF	CAP0603	No	Murata	GRM188R71H471KA01D
5	2	C20,C21	18pF	CAP0603	No	Murata	GRM1885C1H180JA01D
7	2	C27,C32	0.022uF	CAP0603	No	Murata	GRM188R71H223KA01D
8	1	D1	GRN	LED0603	No	Würth electronics	150 060 GS7 500 0
9	4	FB1,FB2,FB3,FB4	2A/0.05DCR	RES0603	No	Murata	BLM18EG221SN1D
10	1	GND	BLACK	TH_TP_60D40	No	Keystone	5001
12	2	J2,J3	HDR_1x3	TH_CONN_1X3P	No	FCI	68000-103HLF
13	4	R1,R17,R19,R20	10.0K	RES0603	No	Panasonic	ERJ-3EKF1002V
14	1	R2	12.1K	RES0603	No	Rohm	CR03ERTF1212
15	2	R3,R10	330E	RES0603	No	Panasonic	ERJ-3EKF3300V
16	8	R4,R5,R6,R7,R11,R12,R13,R14	49.9E	RES0603	No	Yageo America	9C06031A49R9FKHFT
17	2	R8,R15	0E	RES0603	No	Panasonic	ERJ-3GEY0R00V
18	2	R9,R16	0E	RES1210	No	Vishay	CRCW12100000Z0EA
19	1	R18	1K	RES0603	No	Panasonic	ERJ-3GEYJ102V
20	2	R21,R22	2K	RES0603	No	Panasonic	ERJ-3GEYJ202V
21	1	R23	4.7K	RES0603	No	Panasonic	ERJ-3EKF4701V
23	8	SW2,SW3,SW4,SW5,SW6,SW7,SW8,SW9	JS202011CQN	TH_SW_DPDT_6P	No	C&K Components	JS202011CQN
25	2	T1,T2	Pulse - J0011D01BNL	th_conn_pulse_rj45_j0026	No	Pulse Electronics	J0011D01BNL
26	1	U1	LAN9252	IC_QFN64	No	Microchip	LAN9252
27	1	U2	24FC512	IC_SO8	No	Microchip	24FC512
28	1	Y1	25.000MHz	XTAL_HCM49	No	Cardinal Components Inc or Abracon LLC	CSM1Z-A5B2C5-40-25.0D18-F or ABLS-25.000MHZ-B2F-T
29	1	5V	RED	TH_TP_60D40	No	Keystone	5000
30	1	3V3	ORANGE	TH_TP_60D40	No	Keystone	5003

TABLE C-2: EVB-LAN9252-PICTAIL EVALUATION BOARD BILL OF MATERIALS

Item	Qty	Reference	Part	PCB Footprint	DNP
1	4	C1,C3,C6,C17	1.0uF	CAP0603	DNP
6	8	C23,C24,C25,C26,C28,C29,C30,C31	10pF	CAP0402	DNP
11	1	J1	CONNECTOR PCB EDGE 120	Mec_edge_120	DNP
22	1	SW1	sw_pb_2P	sw_pb_2P	DNP
24	2	TP1,TP2	BergStick	TH_TP_60D40	DNP



MICROCHIP

Worldwide Sales and Service

AMERICAS

Corporate Office

2355 West Chandler Blvd.
Chandler, AZ 85224-6199

Tel: 480-792-7200

Fax: 480-792-7277

Technical Support:

[http://www.microchip.com/
support](http://www.microchip.com/support)

Web Address:

www.microchip.com

Atlanta

Duluth, GA

Tel: 678-957-9614

Fax: 678-957-1455

Austin, TX

Tel: 512-257-3370

Boston

Westborough, MA

Tel: 774-760-0087

Fax: 774-760-0088

Chicago

Itasca, IL

Tel: 630-285-0071

Fax: 630-285-0075

Cleveland

Independence, OH

Tel: 216-447-0464

Fax: 216-447-0643

Dallas

Addison, TX

Tel: 972-818-7423

Fax: 972-818-2924

Detroit

Novi, MI

Tel: 248-848-4000

Houston, TX

Tel: 281-894-5983

Indianapolis

Noblesville, IN

Tel: 317-773-8323

Fax: 317-773-5453

Los Angeles

Mission Viejo, CA

Tel: 949-462-9523

Fax: 949-462-9608

New York, NY

Tel: 631-435-6000

San Jose, CA

Tel: 408-735-9110

Canada - Toronto

Tel: 905-673-0699

Fax: 905-673-6509

ASIA/PACIFIC

Asia Pacific Office

Suites 3707-14, 37th Floor
Tower 6, The Gateway
Harbour City, Kowloon

Hong Kong

Tel: 852-2943-5100

Fax: 852-2401-3431

Australia - Sydney

Tel: 61-2-9868-6733

Fax: 61-2-9868-6755

China - Beijing

Tel: 86-10-8569-7000

Fax: 86-10-8528-2104

China - Chengdu

Tel: 86-28-8665-5511

Fax: 86-28-8665-7889

China - Chongqing

Tel: 86-23-8980-9588

Fax: 86-23-8980-9500

China - Dongguan

Tel: 86-769-8702-9880

China - Hangzhou

Tel: 86-571-8792-8115

Fax: 86-571-8792-8116

China - Hong Kong SAR

Tel: 852-2943-5100

Fax: 852-2401-3431

China - Nanjing

Tel: 86-25-8473-2460

Fax: 86-25-8473-2470

China - Qingdao

Tel: 86-532-8502-7355

Fax: 86-532-8502-7205

China - Shanghai

Tel: 86-21-5407-5533

Fax: 86-21-5407-5066

China - Shenyang

Tel: 86-24-2334-2829

Fax: 86-24-2334-2393

China - Shenzhen

Tel: 86-755-8864-2200

Fax: 86-755-8203-1760

China - Wuhan

Tel: 86-27-5980-5300

Fax: 86-27-5980-5118

China - Xian

Tel: 86-29-8833-7252

Fax: 86-29-8833-7256

ASIA/PACIFIC

China - Xiamen

Tel: 86-592-2388138

Fax: 86-592-2388130

China - Zhuhai

Tel: 86-756-3210040

Fax: 86-756-3210049

India - Bangalore

Tel: 91-80-3090-4444

Fax: 91-80-3090-4123

India - New Delhi

Tel: 91-11-4160-8631

Fax: 91-11-4160-8632

India - Pune

Tel: 91-20-3019-1500

Japan - Osaka

Tel: 81-6-6152-7160

Fax: 81-6-6152-9310

Japan - Tokyo

Tel: 81-3-6880-3770

Fax: 81-3-6880-3771

Korea - Daegu

Tel: 82-53-744-4301

Fax: 82-53-744-4302

Korea - Seoul

Tel: 82-2-554-7200

Fax: 82-2-558-5932 or

82-2-558-5934

Malaysia - Kuala Lumpur

Tel: 60-3-6201-9857

Fax: 60-3-6201-9859

Malaysia - Penang

Tel: 60-4-227-8870

Fax: 60-4-227-4068

Philippines - Manila

Tel: 63-2-634-9065

Fax: 63-2-634-9069

Singapore

Tel: 65-6334-8870

Fax: 65-6334-8850

Taiwan - Hsin Chu

Tel: 886-3-5778-366

Fax: 886-3-5770-955

Taiwan - Kaohsiung

Tel: 886-7-213-7828

Taiwan - Taipei

Tel: 886-2-2508-8600

Fax: 886-2-2508-0102

Thailand - Bangkok

Tel: 66-2-694-1351

Fax: 66-2-694-1350

EUROPE

Austria - Wels

Tel: 43-7242-2244-39

Fax: 43-7242-2244-393

Denmark - Copenhagen

Tel: 45-4450-2828

Fax: 45-4485-2829

France - Paris

Tel: 33-1-69-53-63-20

Fax: 33-1-69-30-90-79

Germany - Dusseldorf

Tel: 49-2129-3766400

Germany - Karlsruhe

Tel: 49-721-625370

Germany - Munich

Tel: 49-89-627-144-0

Fax: 49-89-627-144-44

Italy - Milan

Tel: 39-0331-742611

Fax: 39-0331-466781

Italy - Venice

Tel: 39-049-7625286

Netherlands - Drunen

Tel: 31-416-690399

Fax: 31-416-690340

Poland - Warsaw

Tel: 48-22-3325737

Spain - Madrid

Tel: 34-91-708-08-90

Fax: 34-91-708-08-91

Sweden - Stockholm

Tel: 46-8-5090-4654

UK - Wokingham

Tel: 44-118-921-5800

Fax: 44-118-921-5820

07/14/15

Mouser Electronics

Authorized Distributor

Click to View Pricing, Inventory, Delivery & Lifecycle Information:

[Microchip:](#)

[EVB-LAN9252-PICTAIL](#)



Стандарт Электрон Связь

Мы молодая и активно развивающаяся компания в области поставок электронных компонентов. Мы поставляем электронные компоненты отечественного и импортного производства напрямую от производителей и с крупнейших складов мира.

Благодаря сотрудничеству с мировыми поставщиками мы осуществляем комплексные и плановые поставки широчайшего спектра электронных компонентов.

Собственная эффективная логистика и склад в обеспечивает надежную поставку продукции в точно указанные сроки по всей России.

Мы осуществляем техническую поддержку нашим клиентам и предпродажную проверку качества продукции. На все поставляемые продукты мы предоставляем гарантию .

Осуществляем поставки продукции под контролем ВП МО РФ на предприятия военно-промышленного комплекса России , а также работаем в рамках 275 ФЗ с открытием отдельных счетов в уполномоченном банке. Система менеджмента качества компании соответствует требованиям ГОСТ ISO 9001.

Минимальные сроки поставки, гибкие цены, неограниченный ассортимент и индивидуальный подход к клиентам являются основой для выстраивания долгосрочного и эффективного сотрудничества с предприятиями радиоэлектронной промышленности, предприятиями ВПК и научно-исследовательскими институтами России.

С нами вы становитесь еще успешнее!

Наши контакты:

Телефон: +7 812 627 14 35

Электронная почта: sales@st-electron.ru

Адрес: 198099, Санкт-Петербург,
Промышленная ул, дом № 19, литера Н,
помещение 100-Н Офис 331