

MLX90326

Analog 0-5V Sensor Interface IC

1. Features and Benefits

- Analog 0-5V ratiometric output
- Single pin programming (through output)
- Fast response time
- Extended temperature range
- Cost effective “electronic trimming”
- Second order compensation of offset and gain
- Internal temperature sensor provided

2. Application Examples

- Pressure transducers, strain gauges, accelerometers, position sensors, etc...
- Industrial sensors
- Automotive after market sensors
- All resistive bridge sensors

3. Ordering information

Product Code	Temperature Code	Package Code	Option Code	Packing Form Code
MLX90326LFR	L	FR	AAA-000	TU
MLX90326LFR	L	FR	AAA-000	RE

Legend:

Temperature Code: L for Temperature Range -40°C to 150°C
Package Code: FR for SSOP 209 mil
Option Code: xxx-000: Standard version
Packing Form: RE for Reel, TU for Tube
Ordering example: MLX90326LFR-AAA-000-TU

4. Functional Diagram

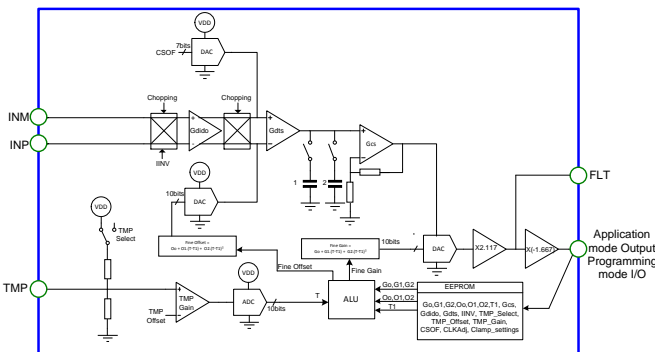

5. General Description

The MLX90326 covers the most typical resistive type of Wheatstone bridge applications for use in an industrial or automotive after market environment. It is a monolithic silicon analog integrated sensor interface that converts small changes in resistors, configured in a full Wheatstone bridge on a sensing element, to large output voltage variations.

The signal conditioning includes gain adjustment, offset control and second order temperature compensation in order to accommodate variations of the different resistive sensing elements. Compensation values are stored in EEPROM and can be reprogrammed with an interface circuit and a provided software.

The MLX90326 is programmed with a single wire serial interface through the output pin.

Contents

1. Features and Benefits.....	1
2. Application Examples.....	1
3. Ordering information.....	1
4. Functional Diagram	1
5. General Description.....	1
6. Absolute Maximum Ratings	3
7. Pin Definitions and Descriptions	4
8. General Electrical Specifications	5
9. General Description.....	7
10. Unique Features	7
11. Application Information.....	8
11.1. Ratio-metric mode with external temperature sensor.	8
11.2. Ratio-metric mode with no external temperature sensor.	9
11.3. Non Ratio-metric mode with external temperature sensor.	9
11.4. Non Ratio-metric mode with no external temperature sensor.	10
12. Standard information regarding manufacturability of Melexis products with different soldering processes.....	11
13. ESD Precautions.....	11
14. Package Information.....	12
15. Contact.....	13
16. Disclaimer.....	13

6. Absolute Maximum Ratings

Parameter.	Min	Max	Units	Comments
Supply Voltage, $V_{DD} - V_{SS}$	4.5	5.5	V	Operating within specifications
Operating Temperature Range, $T_{environment}$	-40	150	°C	
Storage Temperature Range	-50	150	°C	
Programming Temperature Range	-40	125	°C	
Package Thermal Resistance		130	°C/W	
ESD Sensitivity	2		kV	HBM CDF - AEC - Q100-002

Table 1: Absolute maximum ratings

Exceeding the absolute maximum ratings may cause permanent damage. Exposure to absolute-maximum-rated conditions for extended periods may affect device reliability.

7. Pin Definitions and Descriptions

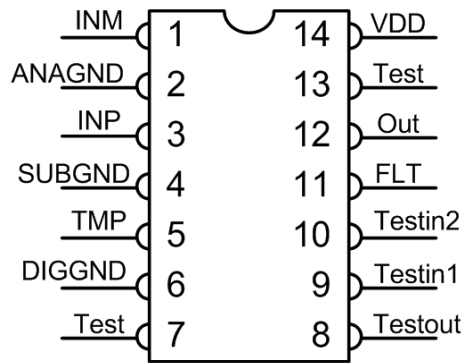

Package Pin Nr	Short Name	Dir	Type	Function / Description
1	INM	IN	Analog	Bridge Sensor Negative
2	ANAGND	gnd		Analog Ground
3	INP	IN	Analog	Bridge Sensor Positive
4	SUBGND	gnd		Substrate Ground
5	TMP	IN	Temp	External Temperature Sensor (Resistor to supply)
6	DIGGND	gnd		Digital Ground
7	Test	NC		On module to ground.
8	TESTOUT	OUT	Test	Test Output. On module to ground
9	TESTIN1	IN	Test	Test Input 1: CLKEXT, TEST (3 level)
10	TESTIN2	IN	Test	Test Input 2: DATAIN, SCAN (3 level)
11	FLT	OUT	Analog	Filter pin
12	OUT	BI	Analog	Analog output and communication pin
13	Test	NC		On module to ground
14	VDD	Power	Supply	Supply

Table 2: Pin definitions and descriptions

8. General Electrical Specifications

DC Operating Parameters $T_A = -40^{\circ}\text{C}$ to 150°C , $V_{DD} = 5.0\text{V}$ (unless otherwise specified)

Parameter.	Symbol	Comments	Min	Typ	Max	Units
Supply Voltage	VDD		4.5		5.5	V
Supply Current	IDD	No output load, $V_{DD}=5\text{V}\pm 10\%$	4		9	mA
Output capacitive load		$10\Omega < R_{\text{SERIES}} < 10\text{ k}\Omega$	0		100	nF
Output resistive load		To reach 5%VDD to 95%VDD	2.4			$\text{k}\Omega$
Output current capability			± 1.9			mA
Output short circuit current		$V_{DD}=5\text{V}\pm 10\%$			± 50	mA
Digital output current			± 2		± 5	mA
V_{DD} line inductance			0		22	μH

Signal path general Specifications						
Parameter.	Symbol	Comments	Min	Typ	Max	Units
Overall gain			12.7		442	V/V
Coarse gain	G_{dido}	1bit programmable	3.25 ($G_{dido} = 0$) 13 ($G_{dido} = 1$)			V/V
	G_{dts}	1bit programmable	2 ($G_{dts} = 0$) 5 ($G_{dts} = 1$)			V/V
	G_{cs}	1bit programmable	1.24 ($G_{cs} = 0$) 1.9375 ($G_{cs} = 1$)			V/V
Fine gain	Fgain	10 bit programmable	0.448		0.99	V/V
Typical sensor output span that can be accommodated to achieve 4V output span			1.8		63	mV/V _{supply}
Typical sensor offset that can be compensated					97.2	mV/V _{supply}
Output Offset programmable			10		90	%V _{DD}
Output Offset resolution					0.1	%V _{DD}
Overall non linearity		Best fit value			±0.1	%V _{DD}
Wake-up time at power up					10	ms
Output noise		47nF FLT capacitance with maximum gain			5	mV _{rms}
Response time		Set by an external capacitor			0.1	ms

Table 3: Electrical specifications

9. General Description

The MLX90326 can be used with almost any type of resistive bridge sensor without the need of any additional signal conditioning.

The differential input signal is offset compensated and amplified to achieve the desired output voltage. With a coarse gain calibration the MLX90326 can easily accommodate sensor output spans in the 1.8mV/V to 63mV/V range to achieve 4 V output span. Sensor output offsets up to 97.2mV/V (depending on the sensor output span and on the desired output offset) can be compensated with the coarse offset calibration to achieve an output offset in the 0.5V to 4.5V range.

10. Unique Features

Offset canceling

The offset of amplifier DIDO is cancelled by using a chopping mechanism. Also the amplifier DTS and all sample-and-hold circuits make use of an offset canceling mechanism. This means that the contribution of the on-chip offsets and offset drifts is negligible compared to the external sensor offset and offset drift.

Coarse and fine second order calibration of the sensitivity and offset.

The MLX90326 can be calibrated to achieve 4V output span for a sensor output span in the 1.8mV/V to 63mV/V and can compensate 0.4mV/V to 97.2mV/V input offset depending on the sensor output span and on the desired MLX90326 output offset voltage. A wide range of sensor sensitivity and offset temperature drift can be compensated with the second order fine gain and offset calibration.

EEPROM

All the calibration data is stored three times on an EEPROM and a majority voting is done when accessing data. Parity check is used to diagnose data corruption. After all calibrations parameters were successfully written to EEPROM, the EEPROM can be locked by sending a 'Lock EEPROM' command (see paragraph 6). This is strongly recommended to avoid in application mode data corruption. For reliability reasons, actually each calibration bit is stored three times in the EEPROM and the circuit uses a hardware majority voting system when accessing data.

11. Application Information

11.1. Ratio-metric mode with external temperature sensor.

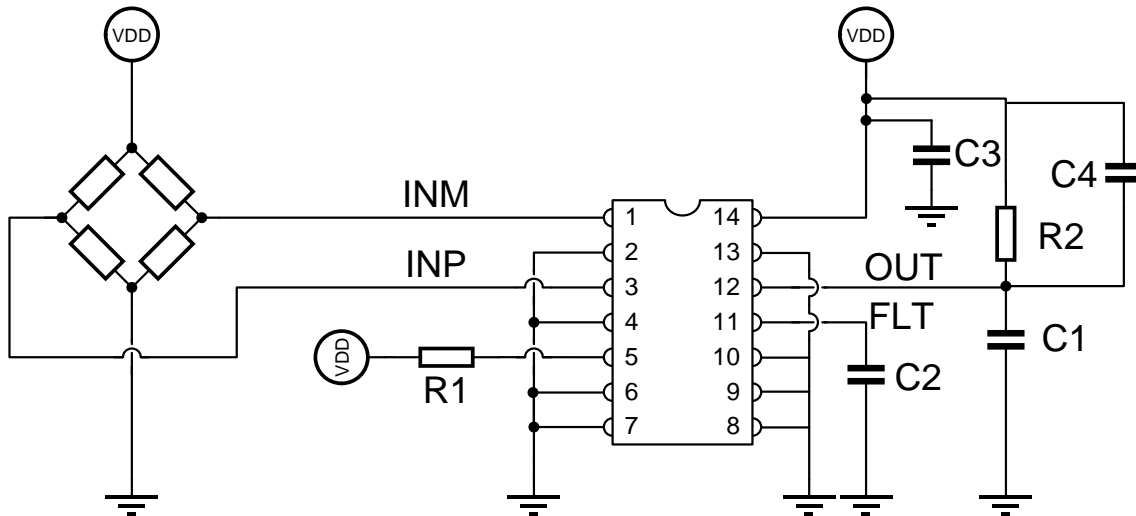

The external temperature sensor is only needed for applications where the temperature surrounding the customer sensor is different from the temperature surrounding the MLX90326. In the ratio-metric application mode, to keep the accuracy, the same supply should be used for the customer sensor, the MLX90326 and an ADC that makes the digital conversion of the analog output signal.

The C1 capacitor value (output) is typically 47nF. Range: 0 – 100nF.

The capacitor C2 on the FLT pin is optional. Typical value = 10nF. Range: 0 – 100nF. It is used to decrease the noise and set the bandwidth of the system. The decoupling capacitors C3 between the supply and the ground and C4 between output and supply have a typical value of 47nF.

The external resistor R1 is placed between the TMP pin and the supply. It is used as an external temperature sensor. The external temperature sensor could be of type Panasonic, ERAS15J103V (R1 = 10k +/- 5%, TCR = 1500ppm/degC +/- 200ppm/degC) for the -40°C to 140°C temperature range.

Typical pull up resistor R2 value is 2.4kOhm.

11.2. Ratio-metric mode with no external temperature sensor.

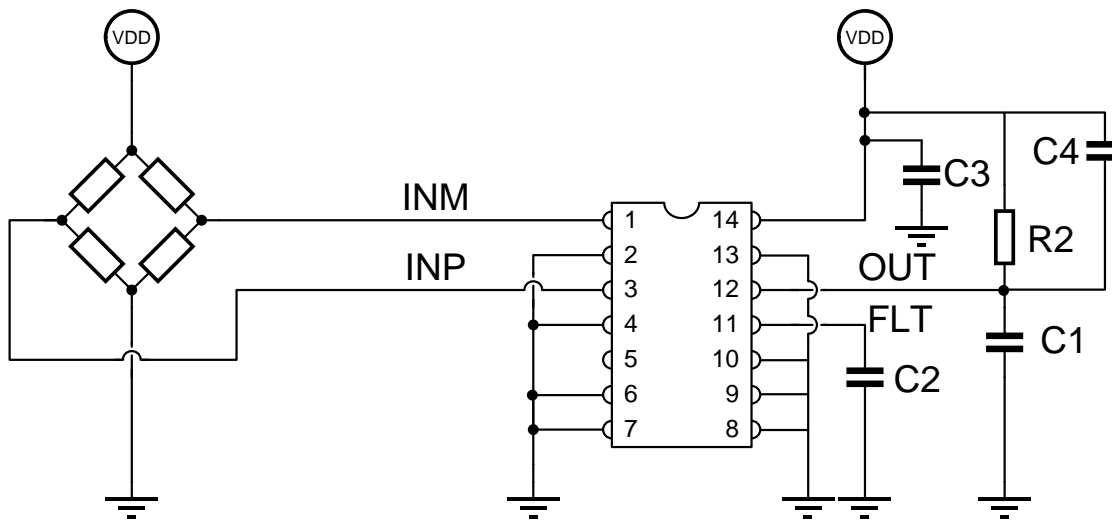

C1, C2, C3, C4 and R2 have the same values as for the ratio-metric application with use of external temperature sensor.

The internal temperature sensor can be used when the temperature surrounding the customer sensor and the MLX90326 is the same.

11.3. Non Ratio-metric mode with external temperature sensor.

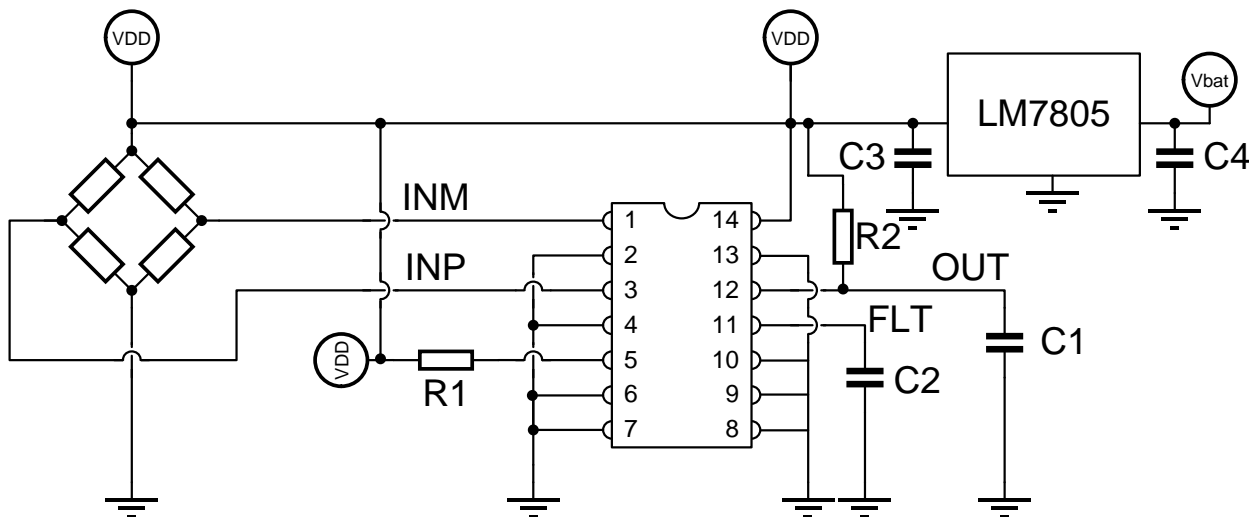

With the use of an external voltage regulator to supply the sensor, the MLX90326 as well as an ADC used for converting the analog output signal, the MLX90326 can be used in a non ratio-metric mode. An example of standard voltage regulator is the LM7805. C1, C2, R1 and R2 are the same as in the ratio-metric application mode. C4 has a typical value of 330nF and C3 of 100nF in this application mode.

11.4. Non Ratio-metric mode with no external temperature sensor.

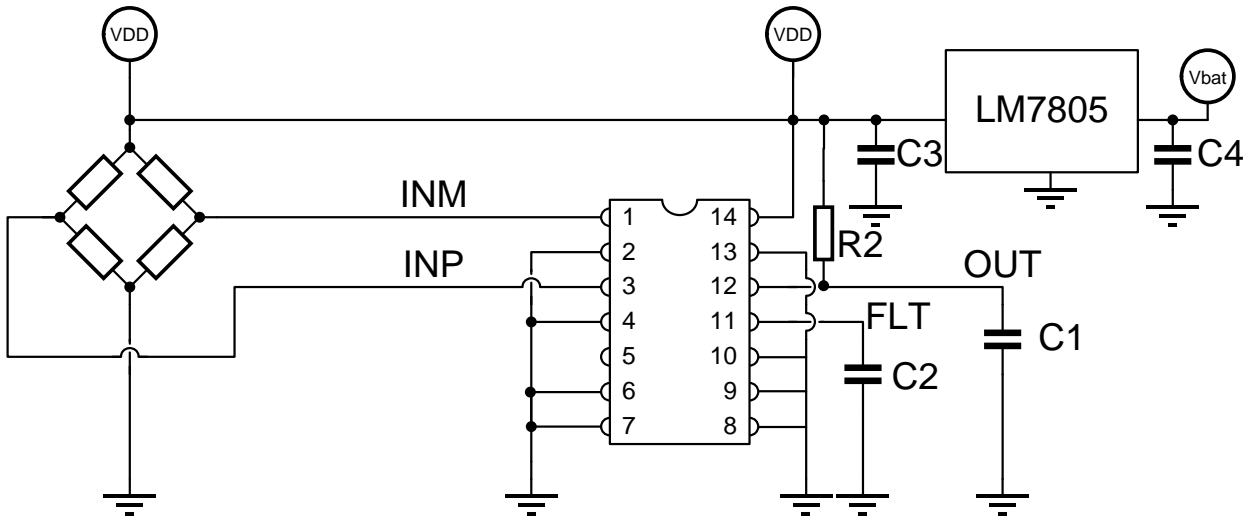

In this application mode the LM7805 generates the supply for the sensor, for the MLX90326 and for an ADC used to convert the analog output signal in a digital value. C1, C2, C3, C4 and R2 are the same as in the non ratio-metric application mode with external temperature sensor.

12. Standard information regarding manufacturability of Melexis products with different soldering processes

Our products are classified and qualified regarding soldering technology, solderability and moisture sensitivity level according to following test methods:

Reflow Soldering SMD's (Surface Mount Devices)

- IPC/JEDEC J-STD-020
Moisture/Reflow Sensitivity Classification for Nonhermetic Solid State Surface Mount Devices (classification reflow profiles according to table 5-2)
- EIA/JEDEC JESD22-A113
Preconditioning of Nonhermetic Surface Mount Devices Prior to Reliability Testing (reflow profiles according to table 2)

Wave Soldering SMD's (Surface Mount Devices) and THD's (Through Hole Devices)

- EN60749-20
Resistance of plastic- encapsulated SMD's to combined effect of moisture and soldering heat
- EIA/JEDEC JESD22-B106 and EN60749-15
Resistance to soldering temperature for through-hole mounted devices

Iron Soldering THD's (Through Hole Devices)

- EN60749-15
Resistance to soldering temperature for through-hole mounted devices

Solderability SMD's (Surface Mount Devices) and THD's (Through Hole Devices)

- EIA/JEDEC JESD22-B102 and EN60749-21
Solderability

For all soldering technologies deviating from above mentioned standard conditions (regarding peak temperature, temperature gradient, temperature profile etc) additional classification and qualification tests have to be agreed upon with Melexis.

The application of Wave Soldering for SMD's is allowed only after consulting Melexis regarding assurance of adhesive strength between device and board.

Melexis is contributing to global environmental conservation by promoting **lead free** solutions. For more information on qualifications of **RoHS** compliant products (RoHS = European directive on the Restriction Of the use of certain Hazardous Substances) please visit the quality page on our website:

<http://www.melexis.com/quality.aspx>

13. ESD Precautions

Electronic semiconductor products are sensitive to Electro Static Discharge (ESD). Always observe Electro Static Discharge control procedures whenever handling semiconductor products.

14. Package Information

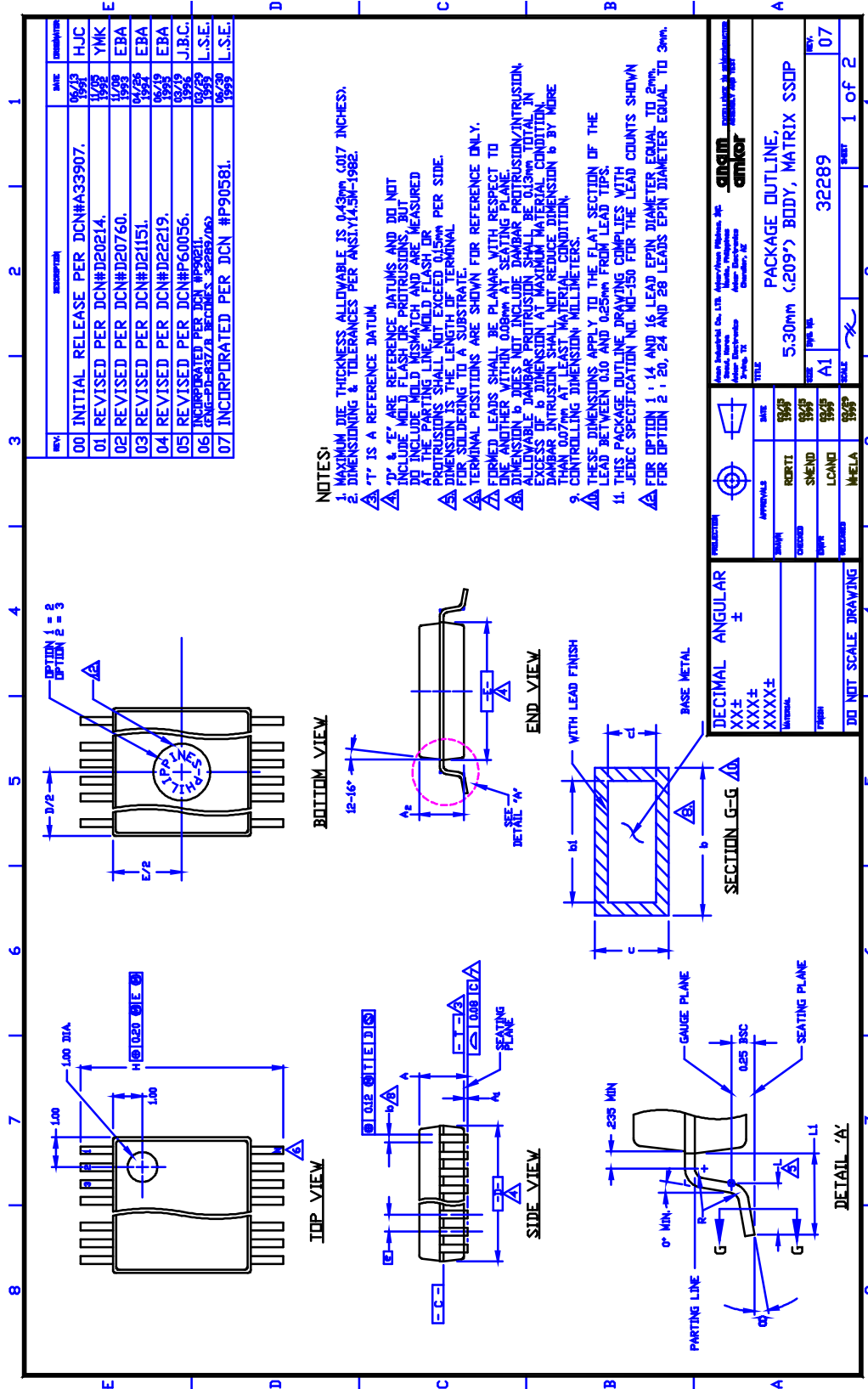

15. Contact

For the latest version of this document, go to our website at www.melexis.com.

For additional information, please contact our Direct Sales team and get help for your specific needs:

Europe, Africa	Telephone: +32 13 67 04 95
	Email : sales_europe@melexis.com
Americas	Telephone: +1 603 223 2362
	Email : sales_usa@melexis.com
Asia	Email : sales_asia@melexis.com

16. Disclaimer

The information furnished by Melexis herein ("Information") is believed to be correct and accurate. Melexis disclaims (i) any and all liability in connection with or arising out of the furnishing, performance or use of the technical data or use of the product(s) as described herein ("Product") (ii) any and all liability, including without limitation, special, consequential or incidental damages, and (iii) any and all warranties, express, statutory, implied, or by description, including warranties of fitness for particular purpose, non-infringement and merchantability. No obligation or liability shall arise or flow out of Melexis' rendering of technical or other services.

The Information is provided "as is" and Melexis reserves the right to change the Information at any time and without notice. Therefore, before placing orders and/or prior to designing the Product into a system, users or any third party should obtain the latest version of the relevant information to verify that the information being relied upon is current.

Users or any third party must further determine the suitability of the Product for its application, including the level of reliability required and determine whether it is fit for a particular purpose.

The Information is proprietary and/or confidential information of Melexis and the use thereof or anything described by the Information does not grant, explicitly or implicitly, to any party any patent rights, licenses, or any other intellectual property rights.

This document as well as the Product(s) may be subject to export control regulations. Please be aware that export might require a prior authorization from competent authorities.

The Product(s) are intended for use in normal commercial applications. Unless otherwise agreed upon in writing, the Product(s) are not designed, authorized or warranted to be suitable in applications requiring extended temperature range and/or unusual environmental requirements. High reliability applications, such as medical life-support or life-sustaining equipment are specifically not recommended by Melexis.

The Product(s) may not be used for the following applications subject to export control regulations: the development, production, processing, operation, maintenance, storage, recognition or proliferation of 1) chemical, biological or nuclear weapons, or for the development, production, maintenance or storage of missiles for such weapons; 2) civil firearms, including spare parts or ammunition for such arms; 3) defense related products, or other material for military use or for law enforcement; 4) any applications that, alone or in combination with other goods, substances or organisms could cause serious harm to persons or goods and that can be used as a means of violence in an armed conflict or any similar violent situation.

The Products sold by Melexis are subject to the terms and conditions as specified in the Terms of Sale, which can be found at <https://www.melexis.com/en/legal/terms-and-conditions>.

This document supersedes and replaces all prior information regarding the Product(s) and/or previous versions of this document.

Melexis NV © - No part of this document may be reproduced without the prior written consent of Melexis. (2016)

ISO/TS 16949 and ISO14001 Certified



Стандарт Электрон Связь

Мы молодая и активно развивающаяся компания в области поставок электронных компонентов. Мы поставляем электронные компоненты отечественного и импортного производства напрямую от производителей и с крупнейших складов мира.

Благодаря сотрудничеству с мировыми поставщиками мы осуществляем комплексные и плановые поставки широчайшего спектра электронных компонентов.

Собственная эффективная логистика и склад в обеспечивает надежную поставку продукции в точно указанные сроки по всей России.

Мы осуществляем техническую поддержку нашим клиентам и предпродажную проверку качества продукции. На все поставляемые продукты мы предоставляем гарантию .

Осуществляем поставки продукции под контролем ВП МО РФ на предприятия военно-промышленного комплекса России , а также работаем в рамках 275 ФЗ с открытием отдельных счетов в уполномоченном банке. Система менеджмента качества компании соответствует требованиям ГОСТ ISO 9001.

Минимальные сроки поставки, гибкие цены, неограниченный ассортимент и индивидуальный подход к клиентам являются основой для выстраивания долгосрочного и эффективного сотрудничества с предприятиями радиоэлектронной промышленности, предприятиями ВПК и научно-исследовательскими институтами России.

С нами вы становитесь еще успешнее!

Наши контакты:

Телефон: +7 812 627 14 35

Электронная почта: sales@st-electron.ru

Адрес: 198099, Санкт-Петербург,
Промышленная ул, дом № 19, литера Н,
помещение 100-Н Офис 331