



User Guide

UG000440

AS6204

Eval Kit

AS6204-EK

v1-01 • 2019-Apr-17

Content Guide

1	Introduction.....	3	4.2	Temperature Register	8
1.1	Kit Content.....	3	5	Schematics, Layers and BOM	9
1.2	Ordering Information	3	5.1	Schematics.....	9
2	Getting Started.....	4	5.2	Layout and Board Dimensions.....	9
3	Hardware Description.....	5	5.3	Bill of Materials.....	11
3.1	Hardware Architecture	5	6	Revision Information.....	12
3.2	AS6204 Configuration	6	7	Legal Information	13
3.3	Power Supply and Connections	6			
4	Software Description.....	7			
4.1	Index Register	7			

1 Introduction

The AS6204 adapter board is a small PCB allowing a simple and quick evaluation of the AS6204 digital temperature sensors without the need to design a custom PCB. This small form factor board is fully assembled with the AS6204 temperature sensor and its necessary external components.

1.1 Kit Content

This kit contains following material listed in Figure 1

Figure 1:
Kit Content

Pos.	Item	Comment
1	AS6204-EK-AB	Eval Kit Adapter Board

1.2 Ordering Information

Figure 2:
Ordering Code

Ordering Code	Description
AS6204-EK	AS6204 Eval Kit

2 Getting Started

The AS6204 adapter board is ideal for rapid setup of a digital temperature sensor. To get started connect the board to your microcontroller configuration as described in Figure 4. Add a command in your source code to request two bytes from the selected I²C address. Finally convert the returned data as described in chapter 4.2 to get the actual temperature value.

Figure 3:
Adapter Board

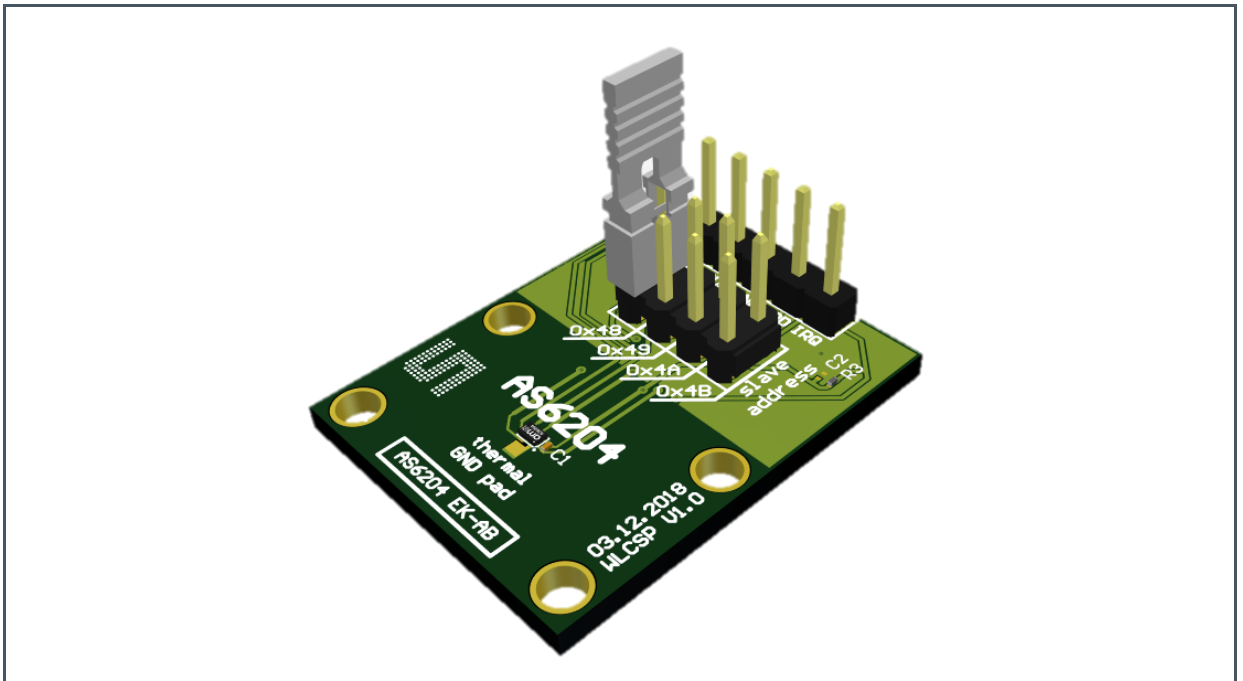

3 Hardware Description

The P1 connector does provide all relevant signals, which can be easily wired to a microcontroller and to the power supply

Figure 4:
Adapter Board Pin-Out

Pin	Symbol	Description	Info
1	SCL	I ² C clock	Use R1 if pull-up is required
2	SDA	I ² C data	Use R2 if pull-up is required
3	GND	Ground	
4	VDD	Power supply	According datasheet
5	IRQ	Digital output pin	Alert interrupt output

3.1 Hardware Architecture

Figure 5:
AS6204 Adapter Board

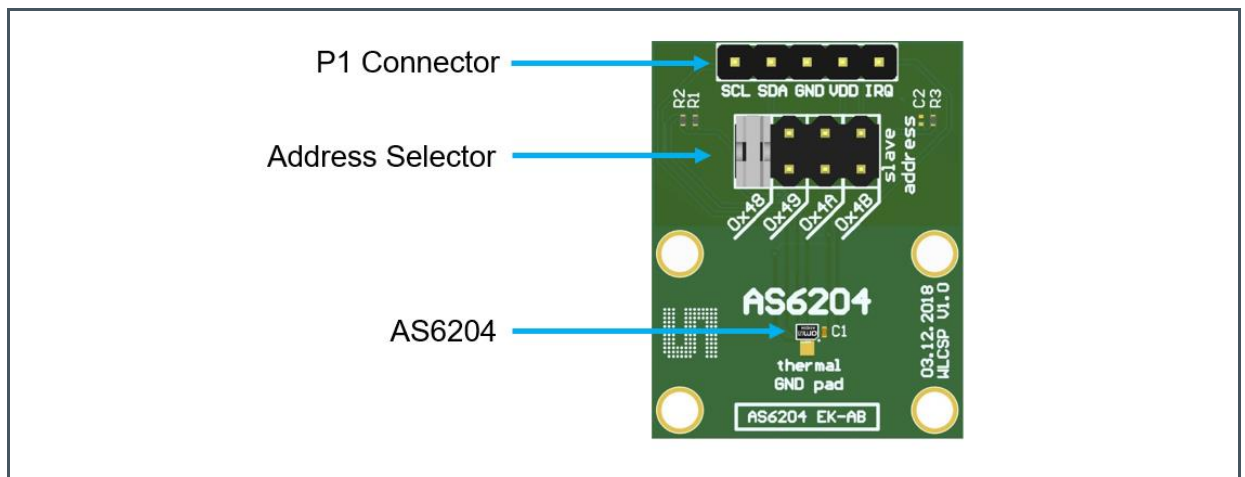

R1, R2 and R3 are pull-up resistors for the I²C interface and the Alert pin. Depending on the application, it is recommended to either populate the decoupling capacitor C1 or C2.

3.2 AS6204 Configuration

With the address selector, it is possible to choose the I²C address of the device. The included jumper is an easy way of setting the I²C address of the sensor. The address selector must not be left open.

Figure 6:
I²C Address

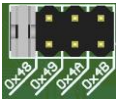
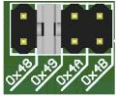
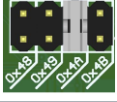
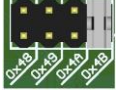
Jumper Settings	Address Selector	Device Address
	GND	100 1000 0x48
	VDD	100 1001 0x49
	SDA	100 1010 0x4A
	SCL	100 1011 0x4B

3.3 Power Supply and Connections

The PCB has to be connected to an external microcontroller. P1 is populated with a 1x5 pin header and is required for power supply as well as I²C communication. In addition to that, it can be used to monitor the interrupt status via pin 5 (IRQ).

Figure 7:
MCU and AS6204 Connections

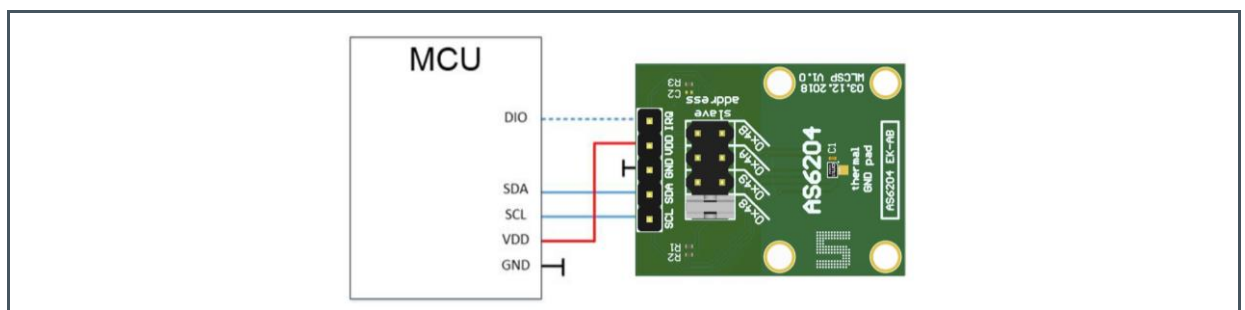

4 Software Description

The AS6204 has 4 data registers. With the use of the index register, it is possible to address the specific data register. When powered up the address register is set to 0x0.

Figure 8:
Data Registers

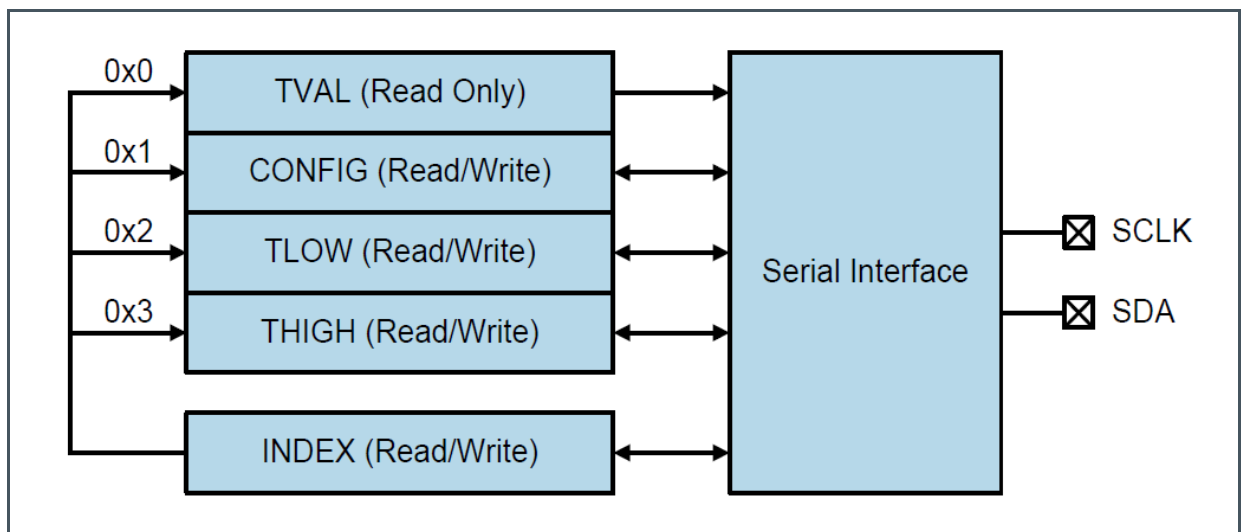

For additional configuration settings, the Config register (0x1) has to be addressed. Please refer the data sheet for details.

Figure 9:
Configuration Register

Address	Symbol	Register	Description
0x0	TVAL		Contains the temperature value
0x1	CONFIG	Configuration Register	Configuration settings of the temperature sensor
0x2	TLOW	T _{LOW} Register	Low temperature threshold value
0x3	THIGH	T _{HIGH} Register	High temperature threshold value

4.1 Index Register

The index register contains 8-bit, but only D0 and D1 are used.

Figure 10:
Index Register

Bit	D7	D6	D5	D4	D3	D2	D1	D0
Value	0	0	0	0	0	0	Address Bits	

4.2 Temperature Register

Figure 11:
Temperature Register

D15	D14	D13	D12	D11	D10	D9	D8	D7	D6	D5	D4	D3	D2	D1	D0
T11	T10	T9	T8	T7	T6	T5	T4	T3	T2	T1	T0	0	0	0	0
MSB Byte								LSB Byte							

The temperature register contains the digitally converted temperature value. It consists of 2 bytes and can be converted according to the following formula:

Positive values= $|Value| / LSB$

Negative values= $Complement(|Value| / LSB) + 1$

Example +75°C

$$75^{\circ}C / 0.0625^{\circ}C = 1200 = Binary\ 0100\ 1011\ 0000 = Hex\ 4B0$$

Example -40°C

$$|-40^{\circ}C| / 0.0625^{\circ}C + 1 = 640 + 1 = Binary\ 0010\ 1000\ 0000 + 1 = 1101\ 0111\ 1111 + 1 = 1101\ 10000\ 0000 = Hex\ D80$$

5 Schematics, Layers and BOM

The schematics, layout and BOM of the adapter board are shown below for reference.

5.1 Schematics

The schematics of the board is shown below in Figure 12:

Figure 12:
Schematics

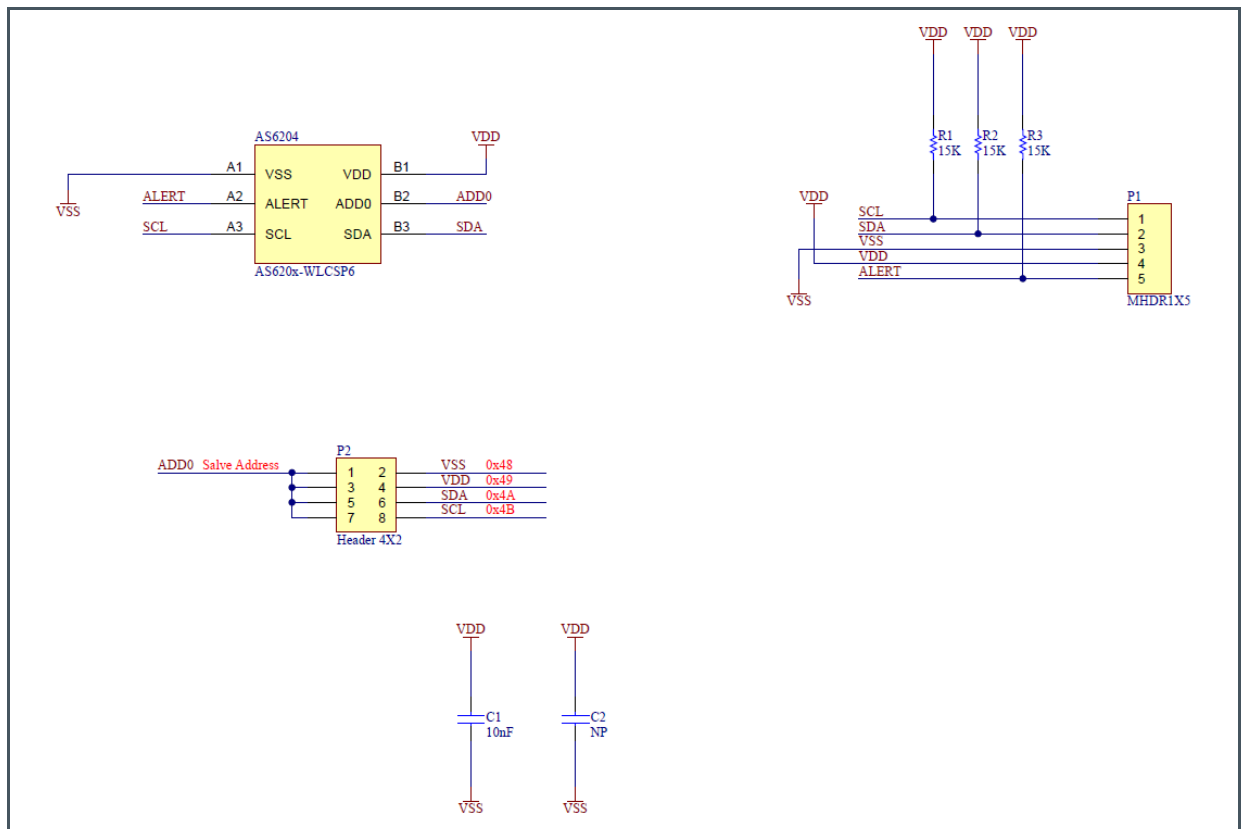

5.2 Layout and Board Dimensions.

The PCB layout is shown below in Figure 13 and Figure 14

Figure 13:
Top Layer

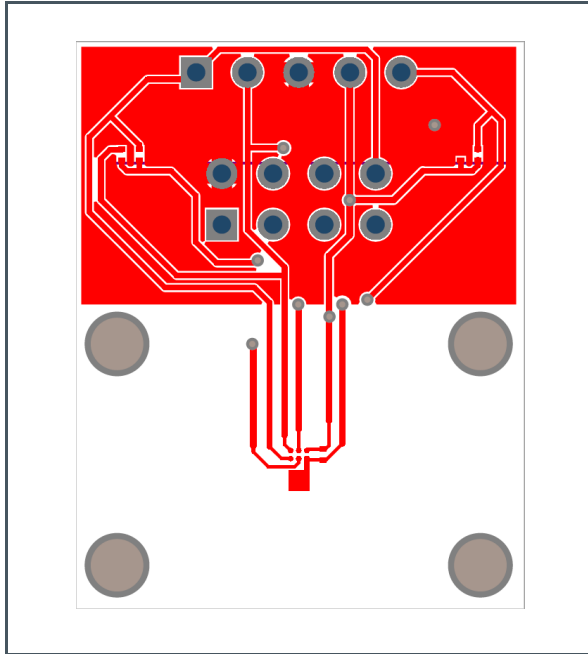
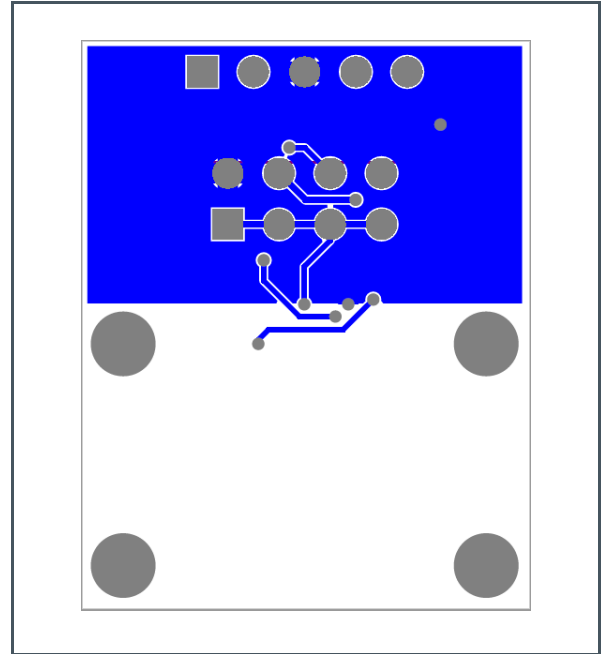
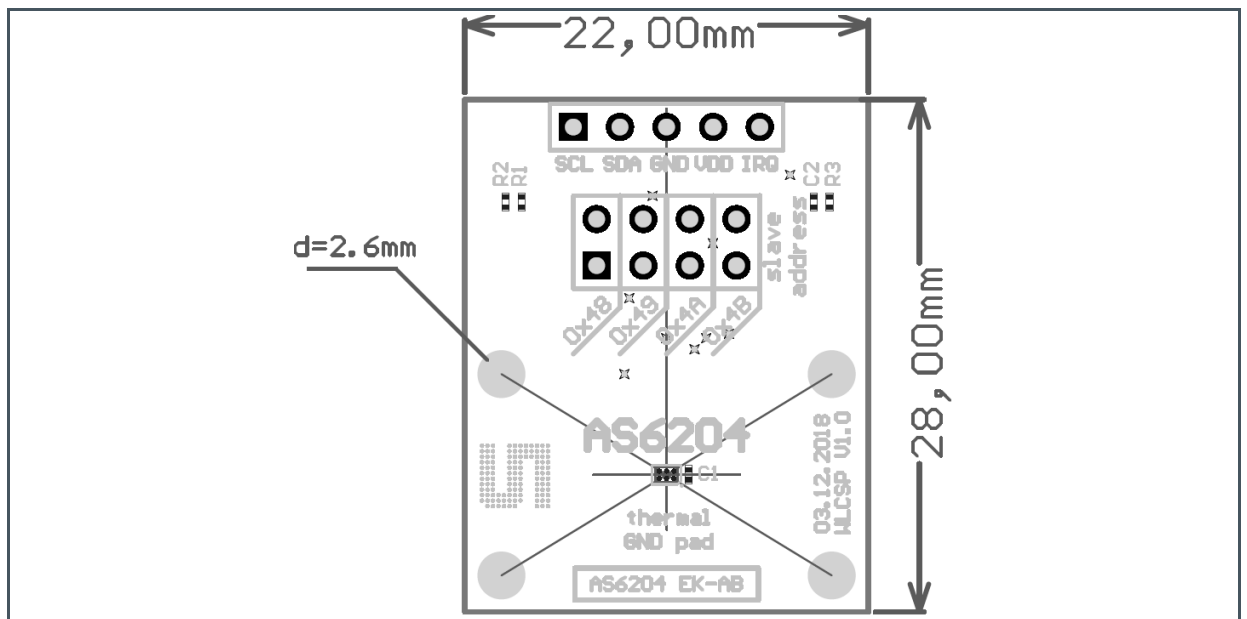

Figure 14:
Bottom Layer



The board dimensions are shown below in Figure 15

Figure 15:
Dimensions



5.3 Bill of Materials

The BOM of the Board is shown below in Figure 16

Figure 16:
BOM

Position	Name	Value
1	R7	NP
2	R6	NP
3	R5	NP
4	R4	NP
5	R3	10 K
6	R2	10 K
7	R1	10 K
8	P1	Header 5
9	C2	NP
10	C1	10 nF
11	AS6204	AS6204 WLCSP

6 Revision Information

Changes from previous version to current revision v1-01	Page
Initial version	

- Page and figure numbers for the previous version may differ from page and figure numbers in the current revision.
- Correction of typographical errors is not explicitly mentioned.

7 Legal Information

Copyrights & Disclaimer

Copyright ams AG, Tobelbader Strasse 30, 8141 Premstaetten, Austria-Europe. Trademarks Registered. All rights reserved. The material herein may not be reproduced, adapted, merged, translated, stored, or used without the prior written consent of the copyright owner.

Demo Kits, Evaluation Kits and Reference Designs are provided to recipient on an "as is" basis for demonstration and evaluation purposes only and are not considered to be finished end-products intended and fit for general consumer use, commercial applications and applications with special requirements such as but not limited to medical equipment or automotive applications. Demo Kits, Evaluation Kits and Reference Designs have not been tested for compliance with electromagnetic compatibility (EMC) standards and directives, unless otherwise specified. Demo Kits, Evaluation Kits and Reference Designs shall be used by qualified personnel only.

ams AG reserves the right to change functionality and price of Demo Kits, Evaluation Kits and Reference Designs at any time and without notice.

Any express or implied warranties, including, but not limited to the implied warranties of merchantability and fitness for a particular purpose are disclaimed. Any claims and demands and any direct, indirect, incidental, special, exemplary or consequential damages arising from the inadequacy of the provided Demo Kits, Evaluation Kits and Reference Designs or incurred losses of any kind (e.g. loss of use, data or profits or business interruption however caused) as a consequence of their use are excluded.

ams AG shall not be liable to recipient or any third party for any damages, including but not limited to personal injury, property damage, loss of profits, loss of use, interruption of business or indirect, special, incidental or consequential damages, of any kind, in connection with or arising out of the furnishing, performance or use of the technical data herein. No obligation or liability to recipient or any third party shall arise or flow out of ams AG rendering of technical or other services.

RoHS Compliant & ams Green Statement

RoHS Compliant: The term RoHS compliant means that ams AG products fully comply with current RoHS directives. Our semiconductor products do not contain any chemicals for all 6 substance categories, including the requirement that lead not exceed 0.1% by weight in homogeneous materials. Where designed to be soldered at high temperatures, RoHS compliant products are suitable for use in specified lead-free processes.

ams Green (RoHS compliant and no Sb/Br): ams Green defines that in addition to RoHS compliance, our products are free of Bromine (Br) and Antimony (Sb) based flame retardants (Br or Sb do not exceed 0.1% by weight in homogeneous material).

Important Information: The information provided in this statement represents ams AG knowledge and belief as of the date that it is provided. ams AG bases its knowledge and belief on information provided by third parties, and makes no representation or warranty as to the accuracy of such information. Efforts are underway to better integrate information from third parties. ams AG has taken and continues to take reasonable steps to provide representative and accurate information but may not have conducted destructive testing or chemical analysis on incoming materials and chemicals. ams AG and ams AG suppliers consider certain information to be proprietary, and thus CAS numbers and other limited information may not be available for release.

Headquarters

ams AG
Tobelbader Strasse 30
8141 Premstaetten
Austria, Europe
Tel: +43 (0) 3136 500 0

Please visit our website at www.ams.com

Buy our products or get free samples online at www.ams.com/Products

Technical Support is available at www.ams.com/Technical-Support

Provide feedback about this document at www.ams.com/Document-Feedback

For sales offices, distributors and representatives go to www.ams.com/Contact

For further information and requests, e-mail us at ams_sales@ams.com



Стандарт Электрон Связь

Мы молодая и активно развивающаяся компания в области поставок электронных компонентов. Мы поставляем электронные компоненты отечественного и импортного производства напрямую от производителей и с крупнейших складов мира.

Благодаря сотрудничеству с мировыми поставщиками мы осуществляем комплексные и плановые поставки широчайшего спектра электронных компонентов.

Собственная эффективная логистика и склад в обеспечивает надежную поставку продукции в точно указанные сроки по всей России.

Мы осуществляем техническую поддержку нашим клиентам и предпродажную проверку качества продукции. На все поставляемые продукты мы предоставляем гарантию .

Осуществляем поставки продукции под контролем ВП МО РФ на предприятия военно-промышленного комплекса России , а также работаем в рамках 275 ФЗ с открытием отдельных счетов в уполномоченном банке. Система менеджмента качества компании соответствует требованиям ГОСТ ISO 9001.

Минимальные сроки поставки, гибкие цены, неограниченный ассортимент и индивидуальный подход к клиентам являются основой для выстраивания долгосрочного и эффективного сотрудничества с предприятиями радиоэлектронной промышленности, предприятиями ВПК и научно-исследовательскими институтами России.

С нами вы становитесь еще успешнее!

Наши контакты:

Телефон: +7 812 627 14 35

Электронная почта: sales@st-electron.ru

Адрес: 198099, Санкт-Петербург,
Промышленная ул, дом № 19, литера Н,
помещение 100-Н Офис 331