

General Description

The MAX5911 evaluation kit (EV kit) is a fully assembled and tested surface-mount circuit board that demonstrates the MAX5911 fully integrated hot-swap solution for negative supply rails. The device allows the safe insertion and removal of circuit cards into live backplanes or ports without causing problematic glitches on the negative power-supply rail. The EV kit operates over a -16V to -65V voltage range and has an adjustable undervoltage lockout (UVLO) set by default to -28V. During startup, the device regulates the current between the backplane power source and the load to 280mA and monitors four fault parameters: UVLO, power-not-good, zero-current detection, and thermal shutdown.

Features

- Provides Safe Hot Swap for -16V to -65V Power Supplies
- 280mA Current Limit
- Adjustable Undervoltage Threshold with a Default Set to -28V
- Zero-Current Detection
- Enable Input/Fault Output
- Adjustable Output-Voltage Gate Ramp
- Proven PCB Layout
- Fully Assembled and Tested

Ordering Information appears at end of data sheet.

Component List

DESIGNATION	QTY	DESCRIPTION
C1	1	0.1µF ±10%, 100V X7R ceramic capacitor (0805) TDK C2012X7R2A104K
C2	0	Not installed, capacitor (E-case)
C3	2	1µF ±10%, 25V X7R ceramic capacitor (0603) Murata GRM188R71E105K TDK C1608X5R1E105M
C4, C5	0	Not installed, ceramic capacitors (0603)
C6	0	Not installed, ceramic capacitor (1210)

DESIGNATION	QTY	DESCRIPTION
FAULT	1	Red test point
JU1	1	2-pin header
R1, R2	0	Not installed, resistors (0603)
R3	1	10kΩ ±5% resistor (0603)
R4	1	3.3kΩ ±5% resistor (0603)
R5	1	0Ω resistor (1206)
R6	0	Not installed, resistor (2512)
U1	1	-48V hot-swap switch (8 SO) Maxim MAX5911ESA
—	1	Shunts
—	1	PCB: MAX5911 EVKIT

Component Suppliers

SUPPLIER	PHONE	WEBSITE
Murata Electronics North America, Inc.	770-436-1300	www.murata-northamerica.com
TDK Corp.	847-803-6100	www.component.tdk.com

Note: Indicate that you are using the MAX5911 when contacting these component suppliers.



Quick Start

Recommended Equipment

- MAX5911 EV kit
- -65V, 0.5A DC power supply (PS1)
- +3.3V, 0.5A DC power supply for logic supply (PS2)
- Dummy load capable of sinking up to 280mA (the current should be above ~15mA)
- Digital voltmeter

Procedure

The EV kit is fully assembled and tested. Follow the steps below to verify operation. **Caution: Do not turn on the power supply until all connections are completed.**

- 1) Connect the negative DC power supply (PS1) across the VIN and AGND PCB pads.
- 2) Connect the +3.3V DC power supply (PS2) across the LOGIC and DGND PCB pads.
- 3) Connect the load across the VOUT and AGND PCB pads.
- 4) Connect a voltmeter between the VOUT and AGND PCB pads.
- 5) Verify that no shunt is installed across jumper JU1.
- 6) Turn on the load and set it to a level between 15mA and 280mA.
- 7) Turn on the +3.3V power supply (PS2) and set the voltage to +3.3V.
- 8) Turn on the negative power supply (PS1) and increase the input voltage to above -28V.
- 9) The EV kit is now ready for further evaluation.

Detailed Description of Hardware

The MAX5911 EV kit demonstrates the MAX5911 fully integrated hot-swap solution for negative supply rails and allows the safe insertion/removal of circuit cards into live backplanes or ports without causing problematic glitches on the negative power-supply rail. The EV kit operates over a -16V to -65V voltage range and has a resistor-adjustable UVLO set internally to -28V. During startup, the device regulates the current between the backplane power source and the load to 280mA and monitors four fault parameters: UVLO, power-not-good, zero-current detection, and thermal shutdown.

Changing the Undervoltage-Lockout Setting

The UVLO value is internally set to -28V if the UVLO pin is left open circuit. The lockout voltage can be changed with a resistive divider from V_{IN} to AGND. Resistor footprints R1 and R2 are provided on the EV kit to provide an option to adjust the UVLO threshold. Use $R1 \geq 10k\Omega$, then calculate R2 using the following equation:

$$R2 = R1 \times \left(\frac{V_{IN(UVLO)}}{1.258} - 1 \right)$$

where $V_{IN(UVLO)}$ is the desired lockout voltage.

Logic Control/Enable Input

The enable input responds to +3.3V or +5V logic signals and forces the internal FET off if it is pulled low. This feature allows the host to disconnect the load from the power bus, if required. Additionally, all fault conditions that latch the internal FET off must be cleared by pulsing ENABLE low for at least 200ns, then reasserting ENABLE before normal operation can resume.

The EV kit provides PCB pads (LOGIC and DGND) to apply the +3.3V or +5V logic supply and jumper JU1 to control the ENABLE input. See Table 1 for jumper JU1 configuration.

Table 1. Enable Input (ENABLE) Jumper JU1 Description

SHUNT POSITION	$\overline{\text{SHDN PIN}}$	DEVICES
Installed	Connected to DGND	Disabled
Not installed*	Pulled high to V_{LOGIC} through resistor R3	Enabled

*Default position.

Gate Connections

GATE connects to the gate of the internal n-channel power MOSFET. Normally this pin should be left open circuit. To slow down the voltage ramp at VOUT, connect capacitors from GATE to VOUT and VIN. Size the capacitors so that the GATE to VIN capacitor (C5) is 10 times the size of the GATE to VOUT capacitor (C4). This technique to slow down the output voltage ramp also causes the output discharge time to increase if the capacitor values exceed approximately 1nF. Additionally, this technique causes the time delay for a power-not-good fault to increase.

Zero-Current Detection

If the load current drops below 8mA (typ) for over 350ms, $\overline{\text{FAULT}}$ is pulled low and the FET is latched off. ENABLE must be pulsed low and then brought high again to release $\overline{\text{FAULT}}$ and enable VOUT.

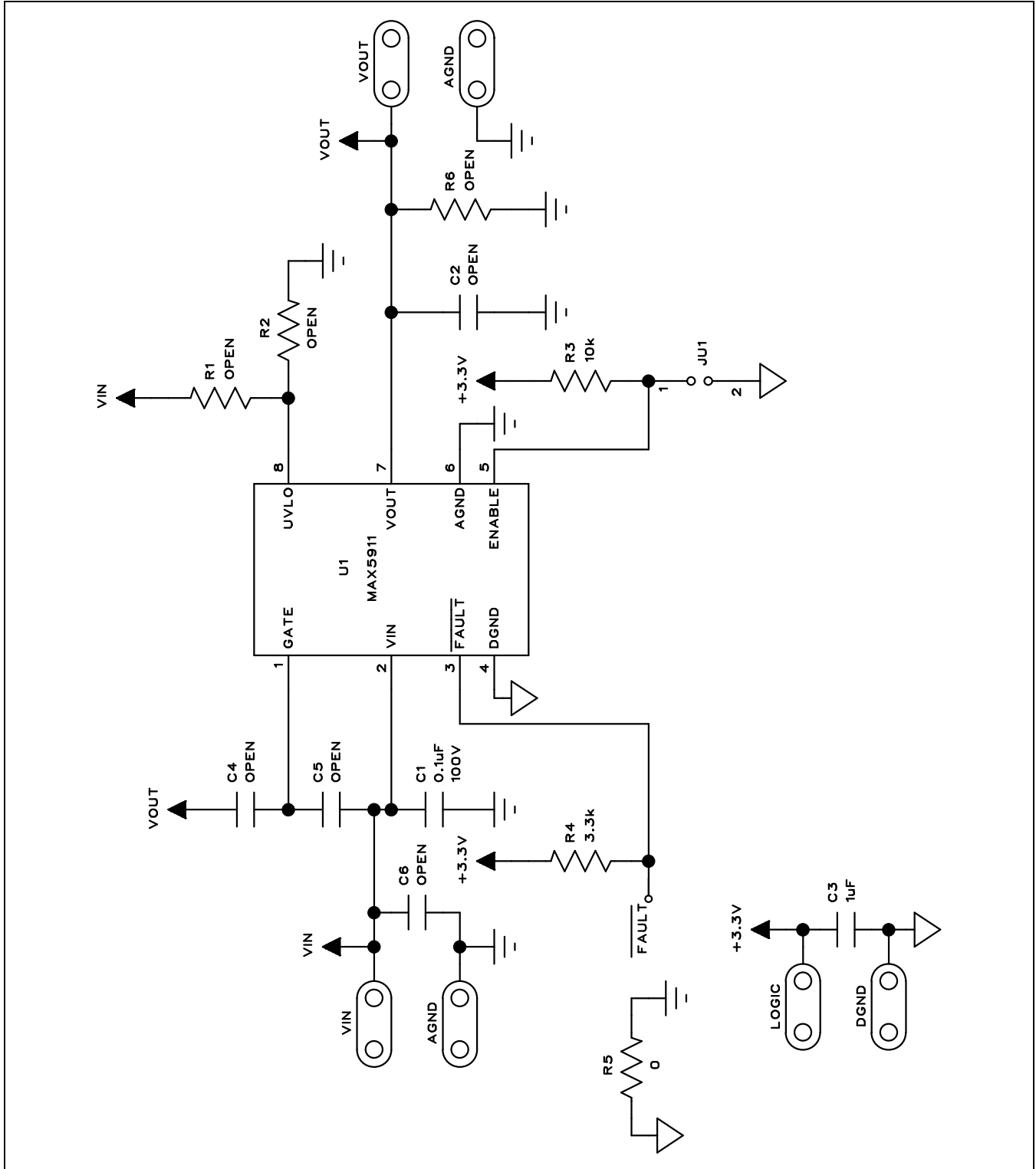

Figure 1. MAX5911 EV Kit Schematic

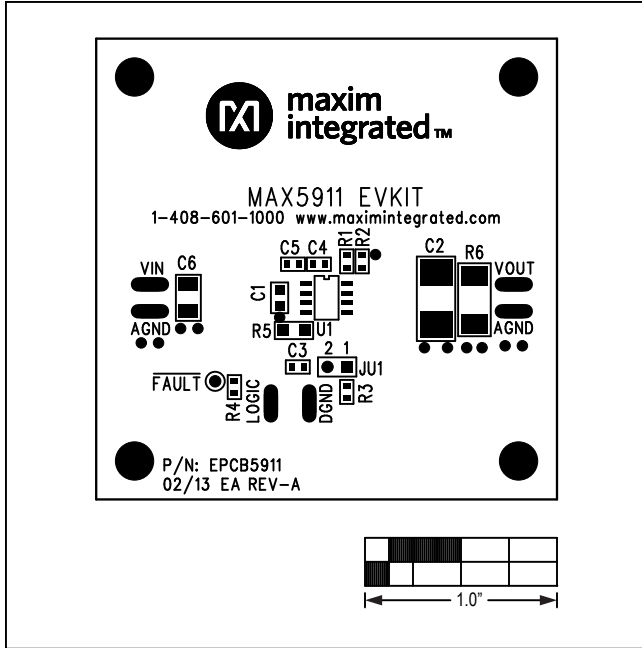

Figure 2. MAX5911 EV Kit Component Placement Guide—Component Side

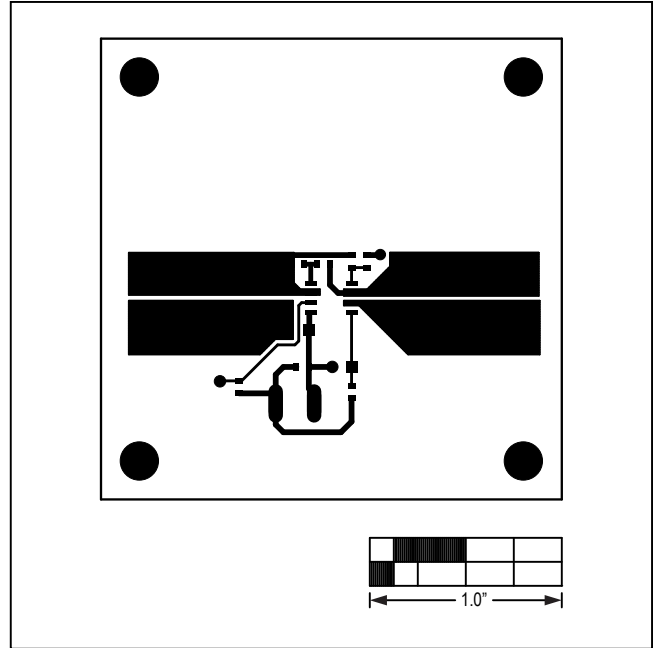

Figure 3. MAX5911 EV Kit PCB Layout—Component Side

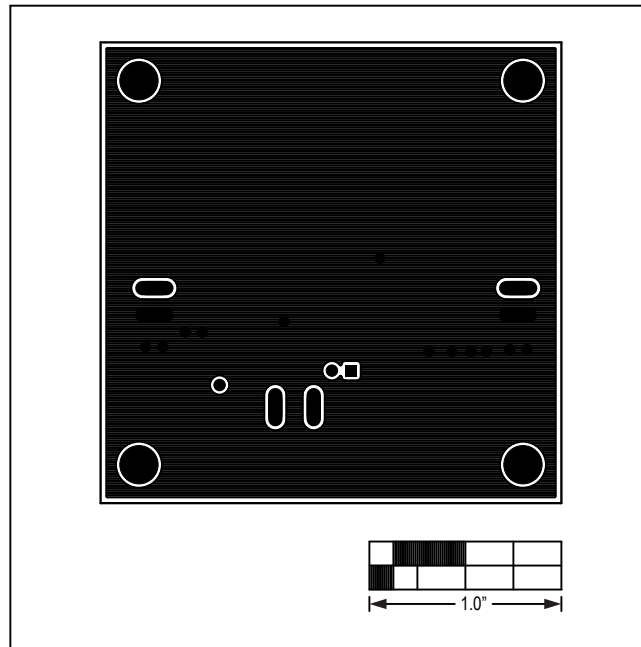

Figure 4. MAX5911 EV Kit PCB Layout—Solder Side

Ordering Information

PART	TYPE
MAX5911EVKIT#	EV Kit

#Denotes RoHS compliant.

Revision History

REVISION NUMBER	REVISION DATE	DESCRIPTION	PAGES CHANGED
0	3/13	Initial release	—

For pricing, delivery, and ordering information, please contact Maxim Direct at 1-888-629-4642, or visit Maxim Integrated's website at www.maximintegrated.com.

Maxim Integrated cannot assume responsibility for use of any circuitry other than circuitry entirely embodied in a Maxim Integrated product. No circuit patent licenses are implied. Maxim Integrated reserves the right to change the circuitry and specifications without notice at any time.



Стандарт Электрон Связь

Мы молодая и активно развивающаяся компания в области поставок электронных компонентов. Мы поставляем электронные компоненты отечественного и импортного производства напрямую от производителей и с крупнейших складов мира.

Благодаря сотрудничеству с мировыми поставщиками мы осуществляем комплексные и плановые поставки широчайшего спектра электронных компонентов.

Собственная эффективная логистика и склад в обеспечивает надежную поставку продукции в точно указанные сроки по всей России.

Мы осуществляем техническую поддержку нашим клиентам и предпродажную проверку качества продукции. На все поставляемые продукты мы предоставляем гарантию .

Осуществляем поставки продукции под контролем ВП МО РФ на предприятия военно-промышленного комплекса России , а также работаем в рамках 275 ФЗ с открытием отдельных счетов в уполномоченном банке. Система менеджмента качества компании соответствует требованиям ГОСТ ISO 9001.

Минимальные сроки поставки, гибкие цены, неограниченный ассортимент и индивидуальный подход к клиентам являются основой для выстраивания долгосрочного и эффективного сотрудничества с предприятиями радиоэлектронной промышленности, предприятиями ВПК и научно-исследовательскими институтами России.

С нами вы становитесь еще успешнее!

Наши контакты:

Телефон: +7 812 627 14 35

Электронная почта: sales@st-electron.ru

Адрес: 198099, Санкт-Петербург,
Промышленная ул, дом № 19, литера Н,
помещение 100-Н Офис 331