

## FEATURES

- 16-element FIFO for event recording
- 10 configurable I/Os allowing for such functions as
  - Keypad decoding for a matrix of up to 5 × 5
  - Key press/release interrupts
- GPIO functions
  - GPI with selectable interrupt level
  - 100 kΩ or 300 kΩ pull-up resistors
  - 300 kΩ pull-down resistors
- GPO with push-pull or open drain
- Programmable logic block
- Pulse generators
  - Periods and on times
    - Above 30 sec in 125 ms increments
    - Up to 255 ms in 1 ms increments
- Reset generator
- I<sup>2</sup>C interface with Fast-mode Plus (Fm+) support of up to 1 MHz
- Open-drain interrupt output
- 16-ball WLCSP, 1.59 mm × 1.59 mm

## APPLICATIONS

- Keypad entries and input/output expansion capabilities
- Smartphones, remote controls, and cameras
- Healthcare, industrial, and instrumentation

## GENERAL DESCRIPTION

The [ADP5586](#) is a 10-input/output port expander with a built-in keypad matrix decoder, programmable logic, reset generator, and pulse generators. Input/output expander ICs are used in portable devices (phones, remote controls, and cameras) and nonportable applications (healthcare, industrial, and instrumentation). I/O expanders can be used to increase the number of I/Os available to a processor or to reduce the number of I/Os required through interface connectors for front panel designs.

The [ADP5586](#) handles all key scanning and decoding and can flag the main processor, via an interrupt line, that new key events have occurred. GPI changes and logic changes can also be tracked



Figure 1.

as events via the FIFO, eliminating the need to monitor different registers for event changes. The [ADP5586](#) is equipped with a FIFO to store up to 16 events. Events can be read back by the processor via an I<sup>2</sup>C-compatible interface.

The [ADP5586](#) eliminates the need for the main processor to monitor the keypad, thus reducing power consumption and/or increasing processor bandwidth for performing other functions.

The programmable logic functions allow common logic requirements to be integrated as part of the GPIO expander, thus saving board area and cost.

**TABLE OF CONTENTS**

Features .....	1	Event FIFO .....	9
Applications.....	1	Key Scan Control.....	10
Functional Block Diagram .....	1	GPI Input .....	13
General Description .....	1	GPO Output .....	13
Revision History .....	2	Logic Block.....	14
Specifications.....	3	Reset Block .....	15
I <sup>2</sup> C Timing Specifications.....	4	Interrupts.....	15
Absolute Maximum Ratings.....	5	Pulse Generators.....	16
Thermal Resistance .....	5	Register Interface.....	17
ESD Caution.....	5	Register Map .....	19
Pin Configuration and Function Descriptions.....	6	Detailed Register Descriptions .....	21
Theory of Operation .....	7	Applications Schematic.....	41
Device Enable.....	8	Outline Dimensions .....	42
Device Overview .....	8	Ordering Guide .....	42
Functional Description .....	9		

**REVISION HISTORY**

3/13—Revision 0: Initial Version

## SPECIFICATIONS

VDD = 1.8 V to 3.3 V, T<sub>A</sub> = T<sub>J</sub> = -40°C to +85°C, unless otherwise noted.<sup>1</sup>

Table 1.

Parameter	Symbol	Test Conditions/Comments	Min	Typ	Max	Unit
<b>SUPPLY VOLTAGE</b>						
VDD Input Voltage Range	VDD		1.65		3.6	V
Undervoltage Lockout Threshold	UVLO <sub>VDD</sub>	UVLO active, VDD falling	1.2	1.3		V
		UVLO inactive, VDD rising		1.4	1.6	V
<b>SUPPLY CURRENT</b>						
Standby Current	I <sub>STNBY</sub>	VDD = 1.65 V		1	4	μA
		VDD = 3.3 V		1	10	μA
Operating Current (One Key Press)	I <sub>SCAN1</sub>	Scan = 10 ms, CORE_FREQ = 50 kHz, scan active, 300 kΩ pull-up, VDD = 1.65 V		30	40	μA
	I <sub>SCAN2</sub>	Scan = 10 ms, CORE_FREQ = 50 kHz, scan active, 300 kΩ pull-up, VDD = 3.3 V		75	85	μA
<b>PULL-UP, PULL-DOWN RESISTANCE</b>						
Pull-Up						
Option 1			50	100	150	kΩ
Option 2			150	300	450	kΩ
Pull-Down			150	300	450	kΩ
<b>INPUT LOGIC LEVEL (RST, SCL, SDA, R0, R1, R2, R3, R4, R5, C0, C1, C2, C3, C4)</b>						
Input Voltage						
Logic Low	V <sub>IL</sub>				0.3 × VDD	V
Logic High	V <sub>IH</sub>		0.7 × VDD			V
Input Leakage Current (Per Pin)	V <sub>I-LEAK</sub>			0.1	1	μA
<b>PUSH-PULL OUTPUT LOGIC LEVEL (R0, R1, R2, R3, R4, R5, C0, C1, C2, C3, C4)</b>						
Output Voltage						
Logic Low	V <sub>OL1</sub>	Sink current = 10 mA, maximum of five GPIOs active simultaneously			0.4	V
	V <sub>OL2</sub>	Sink current = 10 mA, all GPIOs active simultaneously			0.5	V
Logic High	V <sub>OH</sub>	Source current = 5 mA	0.7 × VDD			V
Logic High Output Leakage Current (Per Pin)	V <sub>OH-LEAK</sub>			0.1	1	μA
<b>OPEN-DRAIN OUTPUT LOGIC LEVEL (INT, SDA)</b>						
Output Voltage						
Logic Low						
INT	V <sub>OL3</sub>	I <sub>SINK</sub> = 10 mA			0.4	V
SDA	V <sub>OL4</sub>	I <sub>SINK</sub> = 20 mA			0.4	V
Logic High Output Leakage Current (Per Pin)	V <sub>OH-LEAK</sub>			0.1	1	μA
Logic Propagation Delay				125	300	ns
Flip-Flop (FF) Hold Time <sup>2</sup>				0		ns
FF Setup Time <sup>2</sup>				175		ns
GPIO Debounce <sup>2</sup>					70	μs
Internal Oscillator Frequency <sup>3</sup>	OSC <sub>FREQ</sub>		720	800	880	kHz

<sup>1</sup> All limits at temperature extremes are guaranteed via correlation, using standard statistical quality control (SQC). Typical values are at T<sub>A</sub> = 25°C, VDD = 1.8 V.

<sup>2</sup> Guaranteed by design.

<sup>3</sup> All timers are referenced from the base oscillator and have the same ±10% accuracy.

I<sup>2</sup>C TIMING SPECIFICATIONS

Table 2.

Parameter	Description	Min	Max	Unit
<b>I<sup>2</sup>C TIMING SPECIFICATIONS</b>				
Delay from UVLO/RST Inactive to I <sup>2</sup> C Access			60	μs
f <sub>SCL</sub>	SCL clock frequency	0	1000	kHz
t <sub>HIGH</sub>	SCL high time	0.26		μs
t <sub>LOW</sub>	SCL low time	0.5		μs
t <sub>SU; DAT</sub>	Data setup time	50		ns
t <sub>HD; DAT</sub>	Data hold time	0		μs
t <sub>SU; STA</sub>	Setup time for repeated start	0.26		μs
t <sub>HD; STA</sub>	Hold time for start/repeated start	0.26		μs
t <sub>BUF</sub>	Bus free time for stop and start conditions	0.5		μs
t <sub>SU; STO</sub>	Setup time for stop condition	0.26		μs
t <sub>VD; DAT</sub>	Data valid time		0.45	μs
t <sub>VD; ACK</sub>	Data valid acknowledge		0.45	μs
t <sub>R</sub>	Rise time for SCL and SDA		120	ns
t <sub>F</sub>	Fall time for SCL and SDA		120	ns
t <sub>SP</sub>	Pulse width of suppressed spike	0	50	ns
C <sub>B</sub> <sup>1</sup>	Capacitive load for each bus line		550	pF

<sup>1</sup> C<sub>B</sub> is the total capacitance of one bus line in picofarads (pF).

Timing Diagram

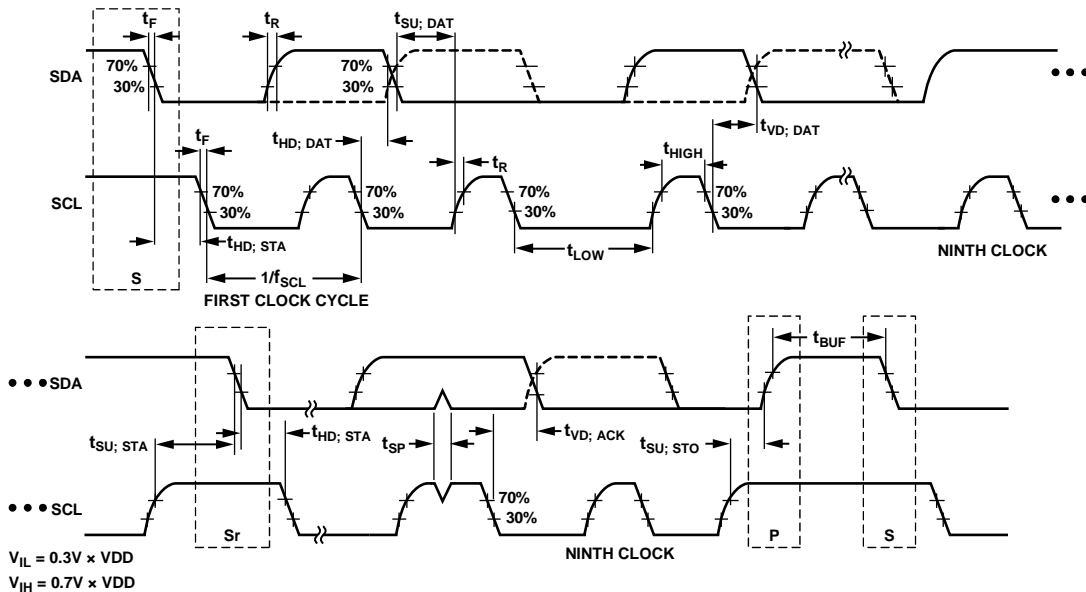

Figure 2. I<sup>2</sup>C Interface Timing Diagram

11148P-002

## ABSOLUTE MAXIMUM RATINGS

Table 3.

Parameter	Rating
VDD to GND	−0.3 V to +4 V
SCL, SDA, $\overline{\text{RST}}$ , $\overline{\text{INT}}$ , R0, R1, R2, R3, R4, C0, C1, C2, C3, C4	−0.3 V to (VDD + 0.3 V)
Temperature Range	
Operating (Ambient)	−40°C to +85°C <sup>1</sup>
Operating (Junction)	−40°C to +125°C
Storage	−65°C to +150°C

<sup>1</sup> In applications where high power dissipation and poor thermal resistance are present, the maximum ambient temperature may need to be derated. Maximum ambient temperature ( $T_{A(MAX)}$ ) is dependent on the maximum operating junction temperature ( $T_{J(MAXOP)} = 125^{\circ}\text{C}$ ), the maximum power dissipation of the device ( $P_{D(MAX)}$ ), and the junction-to-ambient thermal resistance of the device/package in the application ( $\theta_{JA}$ ), using the following equation:  $T_{A(MAX)} = T_{J(MAXOP)} - (\theta_{JA} \times P_{D(MAX)})$ .

Stresses above those listed under Absolute Maximum Ratings may cause permanent damage to the device. This is a stress rating only; functional operation of the device at these or any other conditions above those indicated in the operational section of this specification is not implied. Exposure to absolute maximum rating conditions for extended periods may affect device reliability.

Absolute maximum ratings apply individually only, not in combination. Unless otherwise specified, all other voltages are referenced to GND.

## THERMAL RESISTANCE

$\theta_{JA}$  is specified for the worst-case conditions, that is, a device soldered in a printed circuit board (PCB) for surface-mount packages.

Table 4.

Thermal Resistance	$\theta_{JA}$	Unit
16-Ball WLCSP	62	$^{\circ}\text{C}/\text{W}$
Maximum Power Dissipation	70	mW

## ESD CAUTION



**ESD (electrostatic discharge) sensitive device.** Charged devices and circuit boards can discharge without detection. Although this product features patented or proprietary protection circuitry, damage may occur on devices subjected to high energy ESD. Therefore, proper ESD precautions should be taken to avoid performance degradation or loss of functionality.

## PIN CONFIGURATION AND FUNCTION DESCRIPTIONS



Figure 3. Pin Configuration

Table 5. Pin Function Descriptions

Pin No.	Mnemonic	Description
A1	VDD	Supply Voltage Input.
A2	SDA	I <sup>2</sup> C Data Input/Output.
A3	SCL	I <sup>2</sup> C Clock Input.
A4	GND	Ground.
B1	R0	GPIO 1 (GPIO Alternate Function: Logic Block Output LY). This pin functions as Row 0 when configured in keypad mode.
B2	$\overline{\text{INT}}$	Open-Drain Interrupt Output.
B3	$\overline{\text{RST/R5}}$	Input Reset Signal ( $\overline{\text{RST}}$ ). The reset signal function applies to all models except the ADP5586ACBZ-01-R7. GPIO 6/Row 5 (R5). This function applies only to the ADP5586ACBZ-01-R7 model.
B4	C0	GPIO 7 (GPIO Alternate Function: PULSE_GEN_1). This pin functions as Column 0 when configured in keypad mode.
C1	R2	GPIO 3 (GPIO Alternate Function: Logic Block Input LB). This pin functions as Row 2 when configured in keypad mode.
C2	R1	GPIO 2 (GPIO Alternate Function: Logic Block Input LA). This pin functions as Row 1 when configured in keypad mode.
C3	C1	GPIO 8 (GPIO Alternate Function: PULSE_GEN_2). This pin functions as Column 1 when configured in keypad mode.
C4	C2	GPIO 9. This pin functions as Column 2 when configured in keypad mode.
D1	R4	GPIO 5 (GPIO Alternate Function: RESET_OUT). This pin functions as Row 4 when configured in keypad mode.
D2	R3	GPIO 4 (GPIO Alternate Function: Logic Block Input LC). This pin functions as Row 3 when configured in keypad mode.
D3	C3	GPIO 10. This pin functions as Column 3 when configured in keypad mode.
D4	C4	GPIO 11. This pin functions as Column 4 when configured in keypad mode.

THEORY OF OPERATION



\*R5 AVAILABLE ON ADP5586ACBZ-01-R7 ONLY.

Figure 4. Internal Block Diagram

11148-004

**DEVICE ENABLE**

When sufficient voltage is applied to VDD and the  $\overline{\text{RST}}$  pin is driven with a logic high level, the ADP5586 starts up in standby mode with all settings at default. The user can configure the device via the I<sup>2</sup>C interface. When the  $\overline{\text{RST}}$  pin is low, the ADP5586 enters a reset state and all settings return to default. The  $\overline{\text{RST}}$  pin features a debounce filter.

If the ADP5586ACBZ-01-R7 device model is used, the  $\overline{\text{RST}}$  pin acts as an additional row pin (R5). To reset the part without a reset pin, either bring VDD below the UVLO threshold, or set the SW\_RESET bit to 1 (Register 0x3D, Bit 2).

**DEVICE OVERVIEW**

The ADP5586 contains 10 multiconfigurably input/output pins. Each pin can be programmed to enable the device to carry out its various functions, as follows:

- Keypad matrix decoding (five-column by five-row matrix maximum)
- General-purpose I/O expansion (up to 10 inputs/outputs)
- Reset generator
- Logic function building blocks (up to three inputs and one output)
- Two pulse generators

All 10 input/output pins have an I/O structure as shown in Figure 5.

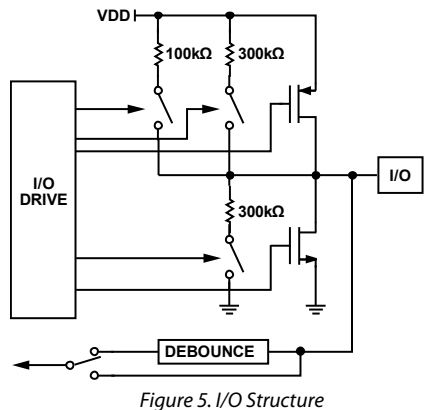

Each I/O can be pulled up with a 100 kΩ or 300 kΩ resistor or pulled down with a 300 kΩ resistor. For logic output drive, each I/O has a 5 mA PMOS source and a 10 mA NMOS sink for a push-pull type output. For open-drain output situations, the 5 mA PMOS source is not enabled. For logic input applications, each I/O can be sampled directly or, alternatively, sampled through a debounce filter.

The I/O structure shown in Figure 5 allows for all GPI and GPO functions, as well as PWM and clock divide functions. For key matrix scan and decode, the scanning circuit uses the 100 kΩ or 300 kΩ resistor for pulling up the keypad row pins and the 10 mA NMOS sinks for grounding the keypad column pins (see the Key Scan Control section for details about key decoding).

Configuration of the device is carried out by programming an array of internal registers via the I<sup>2</sup>C interface. Feedback of device status and pending interrupts can be flagged to an external processor by using the INT pin.

The ADP5586 is offered with three feature sets. Table 6 lists the options that are available for each model of the ADP5586. Contact your local Analog Devices, Inc., field applications engineers for availability and/or alternate configurations.

**Table 6. Matrix Options by Device Model<sup>1</sup>**

Model	Description
ADP5586ACBZ-00-R7	GPIO pull-down on startup
ADP5586ACBZ-01-R7	5-row × 5-column matrix
ADP5586ACBZ-02-R7	Row 5 added to GPIOs
ADP5586ACBZ-03-R7	6-row × 5-column matrix
ADP5586ACBZ-04-R7	Alternate I <sup>2</sup> C address (0x30)
ADP5586ACBZ-05-R7	5-row × 5-column matrix

<sup>1</sup> Contact Analog Devices for availability of configurations not shown here.



# FUNCTIONAL DESCRIPTION

## EVENT FIFO

Before going into detail on the various blocks of the [ADP5586](#), it is important to understand the function of the event FIFO that is featured in the [ADP5586](#). The event FIFO (Register 0x03 to Register 0x12) can record as many as 16 events. By default, the FIFO primarily records key events, such as key press and key release. However, it is possible to configure the general-purpose input (GPI) and logic activity to generate event information on the FIFO, as well. An event count, EC[4:0] (Register 0x02, Bits[4:0]), is composed of five bits and works in tandem with the FIFO so that the user knows how many events are stored in the FIFO.

The FIFO consists of sixteen 8-bit elements. Bits[6:0] of each element store the event identifier, and Bit 7 stores the event state. The user can read the top element of the FIFO from any of the FIFO\_1 through FIFO\_16 registers. The [ADP5586](#) has multiple copies of the FIFO register to allow reading of the complete FIFO with a single I<sup>2</sup>C burst read.

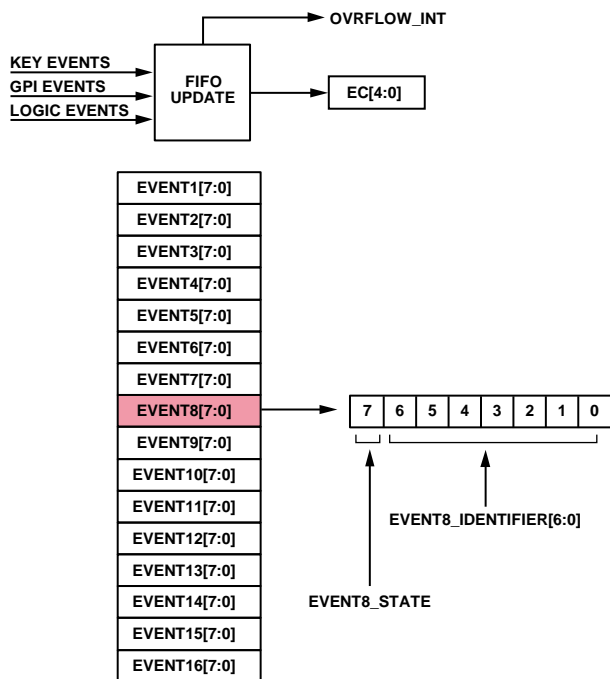

Figure 6. Breakdown of Eventx[7:0] Bits

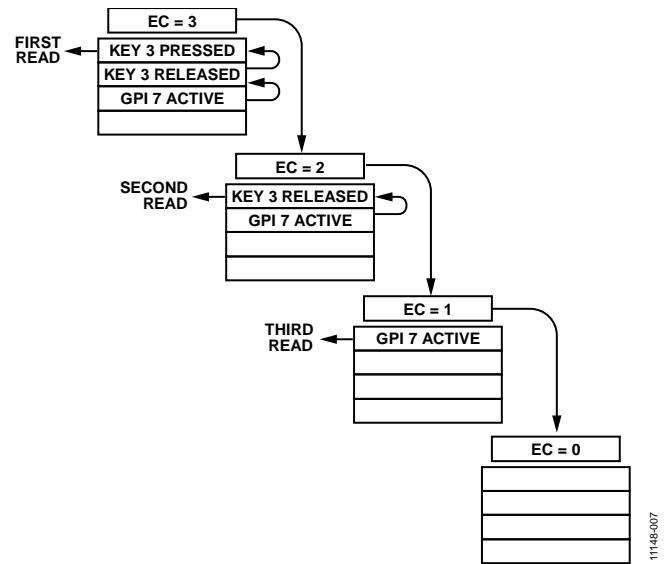

Figure 7. FIFO Operation

The FIFO registers always point to the top of the FIFO (that is, the location of EVENT1[7:0]). If the user tries to read back from any location in a FIFO, data is always obtained from the top of that FIFO. This ensures that events can be read back only in the order in which they occurred, thereby ensuring the integrity of the FIFO system.

As stated previously, some of the on-board functions of the [ADP5586](#) can be programmed to generate events on the FIFO. A FIFO update control block manages updates to the FIFO. If an I<sup>2</sup>C transaction is accessing any of the FIFO address locations, updates are paused until the I<sup>2</sup>C transaction is complete.

A FIFO overflow event occurs when more than 16 events are generated prior to an external processor reading a FIFO and clearing it.

If an overflow condition occurs, the overflow interrupt status bit is set (OVRFLOW\_INT, Register 0x01, Bit 2). An interrupt is generated if an overflow interrupt is enabled, signaling to the processor that more than 16 events have occurred.

**KEY SCAN CONTROL**

**General**

The 10 input/output pins can be configured to decode a keypad matrix up to a maximum size of 25 switches (5 × 5 matrix) using the PIN\_CONFIG\_A, PIN\_CONFIG\_B, and PIN\_CONFIG\_C registers (Registers 0x3A through 0x3C). Smaller matrices can also be configured, making the unused row and column pins available for other I/O functions.

The R0 through R4 I/O pins comprise the rows of the keypad matrix. The C0 through C4 I/O pins comprise the columns of the keypad matrix. Pins that are used as rows are pulled up via the internal 300 kΩ (or 100 kΩ) resistors. Pins that are used as columns are driven low via the internal NMOS current sink.



Figure 8. Simplified Key Scan Block

11148-008

Figure 8 shows a simplified representation of the key scan block using three row pins and three column pins connected to a small 3 × 3, nine-switch keypad matrix. When the key scanner is idle, the row pins are pulled high and the column pins are driven low. The key scanner operates by checking the row pins to see if they are low.

If Switch 6 in the matrix is pressed, R1 connects to C2. The key scan circuit senses that one of the row pins has been pulled low, and a key scan cycle begins. Key scanning involves driving all column pins high, then driving each column pin low, one at a time, and sensing whether a row pin is low. All row/column pairs are scanned; therefore, if multiple keys are pressed, they are detected.

To prevent a glitch or narrow press time from being registered as a valid key press, the key scanner requires that the key be pressed for two scan cycles. The key scanner has a wait time between each scan cycle; therefore, the key must be pressed and held for at least this wait time to register as being pressed. If the key is continuously pressed, the key scanner continues to scan and wait for as long as the key is pressed.

If Switch 6 is released, the connection between R1 and C2 breaks, and R1 is pulled high. The key scanner requires that the key be released for two scan cycles because the release of a key is not necessarily in sync with the key scanner. Up to two full wait/scan cycles may be required for a key to register as released. When the key registers as released, and no other keys are pressed, the key scanner returns to idle mode.

For the remainder of this data sheet, the press/release status of a key is represented as simply a logic signal in the figures. A logic high level represents the key status as pressed, and a logic low level represents released. This eliminates the need to draw individual row/column signals when describing key events.

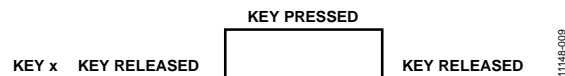

Figure 9. Logic Low: Key Released; Logic High: Key Pressed

11148-009



Figure 10. Detailed Key Scan Block

Figure 10 shows a detailed representation of the key scan block and its associated control and status signals. When all row and column pins are used, a matrix of 25 unique keys can be scanned.

Use the PIN\_CONFIG\_A[5:0] and PIN\_CONFIG\_B[4:0] registers (Register 0x3A and Register 0x3B, respectively) to configure the I/Os for keypad decoding. The number label on each key switch represents the event identifier that is recorded if that switch is pressed. If all row/column pins are configured, it is possible to observe all 25 key identifiers on the FIFO.

If a smaller 2 × 2 matrix is configured, for example, by using the C2 and C3 column pins and the R1 and R2 row pins, only four event identifiers (8, 9, 13, and 14) can possibly be observed on the FIFO, as shown in Figure 10.

By default, the ADP5586 records key presses and releases on the FIFO. Figure 11 illustrates what happens when a single key is pressed and released. Initially, the key scanner is idle. When Key 3 is pressed, the scanner begins scanning through all configured row/column pairs. After the scan wait time, the scanner again scans through all configured row/column pairs and detects that Key 3 has remained pressed, which sets the EVENT\_INT interrupt bit (Register 0x01, Bit 0). The event counter, EC[4:0] (Register 0x02, Bits[4:0]), is then incremented to 1; EVENT1\_IDENTIFIER[6:0] of the FIFO is updated with its event identifier set to 3; and its EVENT1\_STATE bit is set to 1, indicating a key press.

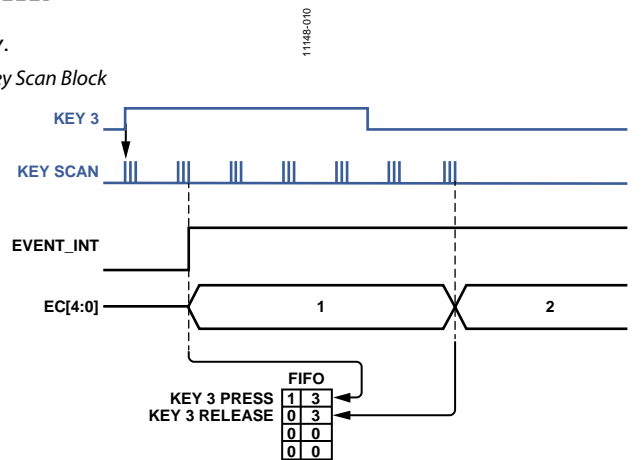

Figure 11. Press and Release Event

The key scanner continues the scan/wait cycles while the key remains pressed. If the scanner detects that the key has been released for two consecutive scan cycles, the event counter, EC[4:0], is incremented to 2, and EVENT2\_IDENTIFIER[6:0] of the FIFO is updated with its event identifier set to 3. The EVENT2\_STATE bit is set to 0, indicating a release. The key scanner returns to idle mode because no other keys are pressed.

The EVENT\_INT interrupt (Register 0x01, Bit 0) can be triggered by both press and release key events. As shown in Figure 12, if Key 3 is pressed, EVENT\_INT is asserted, EC[4:0] is updated, and the FIFO is updated. During the time that the key remains pressed, it is possible for the FIFO to be read, the event counter decremented to 0, and EVENT\_INT cleared. When the key is finally released, EVENT\_INT is asserted, the event counter is incremented, and the FIFO is updated with the release event information.



Figure 12. Asserting the EVENT\_INT Interrupt Keypad Extension

As shown in Figure 10, the keypad can be extended if each row is connected directly to ground by a switch. If the switch placed between R0 and ground is pressed, the entire row is grounded. When the key scanner completes scanning, it normally detects Key 1 to Key 5 as being pressed; however, this unique condition is decoded by the ADP5586, and Key Event 31 is assigned to it. Up to five more key event assignments are possible, allowing the keypad size to extend up to 30. However, if one of the extended keys is pressed, none of the keys on that row is detectable. The activation of a ground key causes all other keys sharing that row to be undetectable.

**Precharge Time**

During a scan sequence, a row scans through the columns sequentially. Each row/column combination is tested at a rate that is defined by the KEY\_POLL\_TIME bits (Register 0x39, Bits[1:0]). Within each of these scan times, each column is scanned for a time defined by the PRECHARGE\_TIME bit (Register 0x39, Bit 3). As shown in Figure 13, the resistance capacitance (RC) time constant, which is defined by the series resistance (from pull-up/pull-down, for example) and parallel capacitance that is seen on the individual columns, affects the sampling of a key press event.

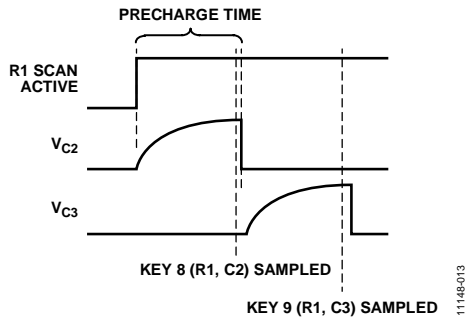

Figure 13. Precharge Time

The ADP5586 samples the state of the row/column pairs near the end of the precharge time. By extending this time, higher RC time constants can be accommodated. For applications that use physical buttons, the RC time constant is usually not an issue, but if external relay switches or multiple external muxes are attached to columns, the RC constant may increase. Using a smaller pull-up resistor on the rows (Register 0x3C, Bit 7) reduces the RC time constant.

**Ghosting**

Ghosting is an occurrence where, given certain key press combinations on a keypad matrix, a false positive reading of an additional key is detected. Ghosting is created when three or more keys are pressed simultaneously on multiple rows or columns (see Figure 14). Key combinations that form a right angle on the keypad matrix may cause ghosting.

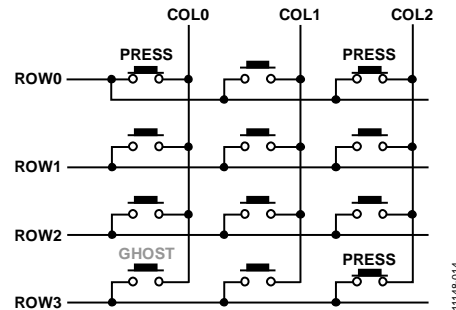

Figure 14. Ghosting Example: Column 0/Row 3 is a Ghost Key Due to a Short Among Row 0, Column 0, Column 2, and Row 3 During Key Press

The solution to ghosting is to select a keypad matrix layout that takes into account three key combinations that are most likely to be pressed together. Multiple keys that are pressed across one row or across one column do not cause ghosting. Staggering keys so that they do not share a column also avoids ghosting. The most common practice is to place keys in the same row or column that are likely to be pressed at the same time. Some examples of keys that are likely to be pressed at the same time are as follows:

- The navigation keys in combination with the Select key
- The navigation keys in combination with the space bar
- The reset combination keys, such as CTRL + ALT + DEL

**GPI INPUT**

Each of the 10 input/output lines can be configured as a general-purpose logic input line using the GPIO\_INP\_EN\_A and GPIO\_INP\_EN\_B registers (Register 0x29 and Register 0x2A). GPIO lines can be configured to allow both input and output at the same time. Figure 15 shows a detailed representation of the GPI scan and detect block and its associated control and status signals.

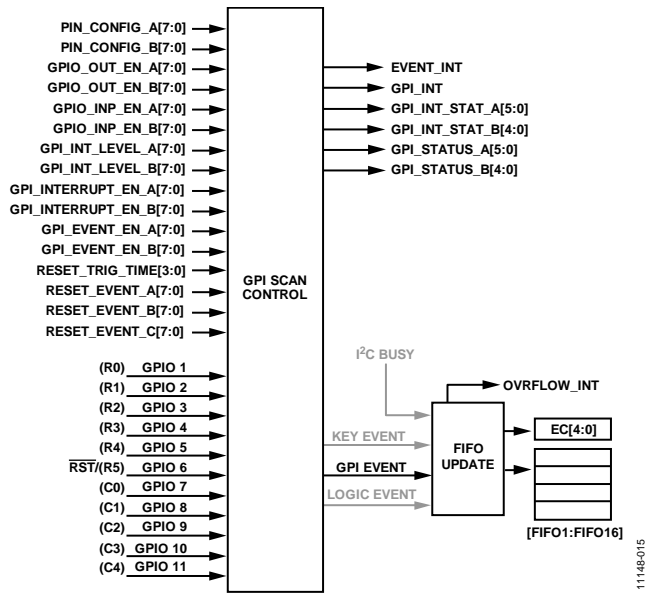

Figure 15. GPI Scan and Detect Block

The current input state of each GPI can be read back using the GPI\_STATUS\_x registers (Register 0x15 and Register 0x16). Each GPI can be programmed to generate an interrupt via the GPI\_INTERRUPT\_EN\_x registers (Register 0x1F and Register 0x20). The interrupt status is stored in the GPI\_INT\_STAT\_x registers (Register 0x13 and Register 0x14). GPI interrupts can be programmed to trigger on the positive or negative edge by configuring the GPI\_INT\_LEVEL\_x registers (Register 0x1B and Register 0x1C). If any GPI interrupt is triggered, the master GPI\_INT interrupt bit (Register 0x01, Bit 1) is also triggered. Figure 16 shows a single GPI and how it affects its corresponding status and the interrupt status bits.

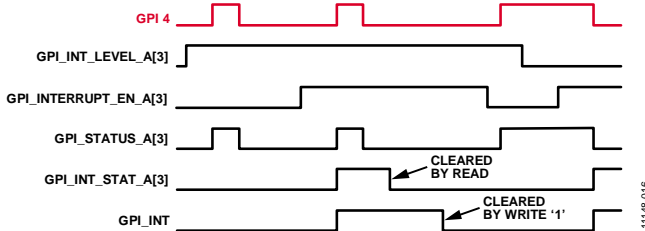

Figure 16. Single GPI Example

GPIs can be programmed to generate FIFO events via the GPI\_EVENT\_EN\_x registers (Register 0x1D and Register 0x1E). GPIs in this mode do not generate GPI\_INT interrupts. Instead, they generate EVENT\_INT interrupts (Register 0x01, Bit 0). Figure 17 shows several GPI lines and their effects on the FIFO and event count, EC[4:0].



Figure 17. Multiple GPI Example

The GPI scanner is idle until it detects a level transition. It then scans the GPI inputs and updates accordingly. After updating, it returns immediately to idle; it does not scan/wait, like the key scanner. As a result, the GPI scanner can detect both edges of narrow pulses after they pass the 70 μs input debounce filter.

**GPO OUTPUT**

Each of the 10 input/output lines can be configured as a general-purpose output (GPO) line using the GPIO\_OUT\_EN\_A and GPIO\_OUT\_EN\_B registers (Register 0x27 and Register 0x28). GPIO lines can be configured to allow both input and output at the same time (see Figure 5 for a detailed diagram of the I/O structure). GPO configuration and usage are programmed in the GPO\_DATA\_OUT\_x and GPO\_OUT\_MODE\_x registers (Register 0x23 to Register 0x26). See the Detailed Register Descriptions section for more information.

**LOGIC BLOCK**

Several of the ADP5586 input/output lines can be used as inputs and outputs for implementing some common logic functions.

The R1, R2, and R3 input/output pins can be used as inputs, and the R0 input/output pin can be used as an output for the logic block. When the R1, R2, and R3 input lines are used, the GPIO\_4\_INP\_EN, GPIO\_3\_INP\_EN, and GPIO\_2\_INP\_EN bits (Register 0x29, Bits[3:1]) must be enabled to accept inputs.

When the R0 pin is used as an output for the logic block, the GPIO\_1\_OUT\_EN bit (Register 0x27, Bit 0) must be enabled.

The outputs from the logic block can be configured to generate interrupts. They can also be configured to generate events on the FIFO.

Figure 19 shows a detailed diagram of the internal makeup of the logic block, illustrating the possible logic functions that can be implemented.



Figure 18. Logic Block Overview



Figure 19. Logic Block Internal Makeup

### RESET BLOCK

The ADP5586 features a reset block that can generate reset conditions if certain events are detected simultaneously. Up to three reset trigger events can be programmed for RESET\_OUT. The event scan control blocks monitor whether these events are present for the duration of RESET\_TRIG\_TIME[3:0] (Register 0x2E, Bits[5:2]). If they are present, reset-initiate signals are sent to the reset generator blocks. The generated reset signal pulse width is programmable.



Figure 20. Reset Blocks

The RESET\_OUT signal uses the R4 I/O pin as its output, which must be configured via the GPIO\_5\_OUT\_EN bit (Register 0x27, Bit 4) to enable the output function. A pass-through mode also allows the RST pin function to be output on the R4 pin.

The reset generation signals are useful in situations where the system processor has locked up and the system is unresponsive to input events. The user can press one of the reset event combinations and initiate a system-wide reset, which eliminates the need to remove the battery from the system and perform a hard reset.

The use of the immediate trigger time setting (see Table 55) is recommended only in very low noise conditions with good debounce; otherwise, false triggering may occur.

### INTERRUPTS

The INT pin can be asserted low if any of the internal interrupt sources is active. The user can select which internal interrupts interact with the external interrupt pin in Register 0x3E (see Table 71). Register 0x3D allows the user to choose whether the external interrupt pin remains asserted, or deasserts for 50 μs and then reasserts, as in the case where multiple internal interrupts are asserted and one is cleared (see Table 70).

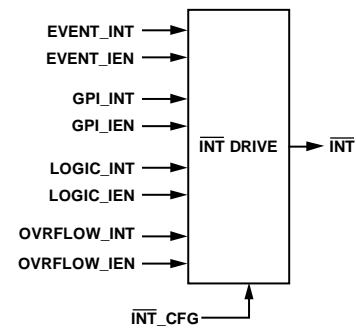

Figure 21. Asserting INT Low

**PULSE GENERATORS**

The ADP5586 contains two pulse generators that are suitable for driving indicator LED drive signals, as well as watchdog timers and other extended time pulsed applications. The ADP5586 allows for eight bits of definition for both the on time and period of the generated pulse. To allow for extended timings, the user can choose between a 1 ms clock and a 125 ms clock to increment these timers. The PULSE\_GEN\_1\_PERIOD and PULSE\_GEN\_2\_PERIOD registers (Register 0x30 and Register 0x33, respectively) define the periods of the two pulse generators. Choosing a clock period of 125 ms in the PULSE\_GEN\_CONFIG register (Register 0x35, Bit 1 and Bit 5) allows for the setting of pulse generator periods of up to 31.875 sec. Setting the PULSE\_GEN\_x\_ON\_CLK bit to a step size of 125 ms and the PULSE\_GEN\_x\_PRD\_CLK bit to a step size of 1 ms is not a supported configuration.

To support active low applications, a signal inversion can be programmed in the PULSE\_GEN\_CONFIG register, using Bit 7 and Bit 3 (PULSE\_GEN\_x\_INV). Delays can be introduced to create synchronized offsets between the channels. If both channels are enabled at the same time (that is, enabled from the same I<sup>2</sup>C write), the difference in delays is the offset between the channels. If a single channel is active and delays are to be synchronized, the user must first disable both pulse generators before enabling both pulse generators with the same I<sup>2</sup>C write command. The delay counter uses the same clock selection as the period counter. See Table 56 through Table 61 for more details. To enable pulse generator output on C1 and/or C0, the GPIO\_8\_OUT\_EN bit and/or the GPIO\_7\_OUT\_EN bit (Register 0x28, Bits[1:0]) must be enabled.



Figure 22. Pulse Generator Block Diagram

11148-022

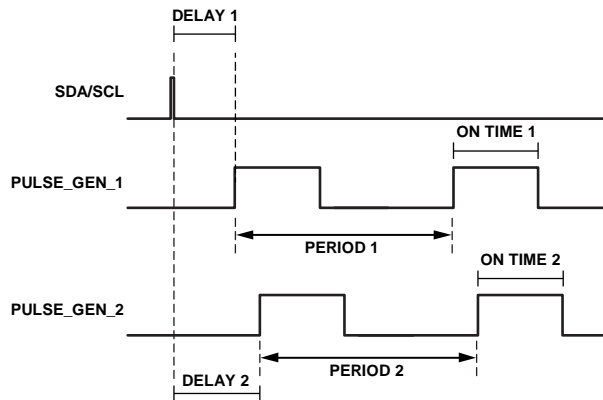

Figure 23. Example Pulse Generator Timing

11148-023



## REGISTER INTERFACE

Register access to the [ADP5586](#) is acquired via its I<sup>2</sup>C-compatible serial interface. The interface can support clock frequencies of up to 1 MHz. If the user is accessing the FIFO or key event counter (KEC), FIFO/KEC updates are paused. If the clock frequency is very low, events may not be recorded in a timely manner. FIFO or KEC updates can happen up to 23 μs after an interrupt is asserted because of the number of I<sup>2</sup>C cycles required to perform an I<sup>2</sup>C read or write. This delay should not present an issue to the user.

Figure 24 shows a typical write sequence for programming an internal register. The cycle begins with a start condition, followed by the hard coded 7-bit device address, which for the [ADP5586](#) is 0x34, followed by the R/W bit set to 0 for a write cycle. The [ADP5586](#) acknowledges the address byte by pulling the data line low. The address of the register to which data is to be written is sent next. The [ADP5586](#) acknowledges the register pointer byte by pulling the data line low. The data byte to be written is sent next. The [ADP5586](#) acknowledges the data byte by pulling the data line low. A stop condition completes the sequence.

Figure 25 shows a typical multibyte write sequence for programming internal registers. The cycle begins with a start condition followed by the 7-bit device address (0x34), followed by the

R/W bit, which is set to 0 for a write cycle. The [ADP5586](#) acknowledges the address byte by pulling the data line low. The address of the register to which data is to be written is sent next. The [ADP5586](#) acknowledges the register pointer byte by pulling the data line low. The data byte to be written is sent next. The [ADP5586](#) acknowledges the data byte by pulling the data line low. The pointer address is then incremented to write the next data byte, until it finishes writing the n data byte. The [ADP5586](#) pulls the data line low after every byte, and a stop condition completes the sequence.

Figure 26 shows a typical byte read sequence for reading internal registers. The cycle begins with a start condition followed by the 7-bit device address, followed by the R/W bit set to 0 for a write cycle. The [ADP5586](#) acknowledges the address byte by pulling the data line low. The address of the register from which data is to be read is sent next. The [ADP5586](#) acknowledges the register pointer byte by pulling the data line low. A start condition is repeated, followed by the 7-bit device address (0x34), followed by the R/W bit set to 1 for a read cycle. The [ADP5586](#) acknowledges the address byte by pulling the data line low. The 8-bit data is then read. The host pulls the data line high (no acknowledge), and a stop condition completes the sequence.



Figure 24. I<sup>2</sup>C Single Byte Write Sequence



Figure 25. I<sup>2</sup>C Multibyte Write Sequence

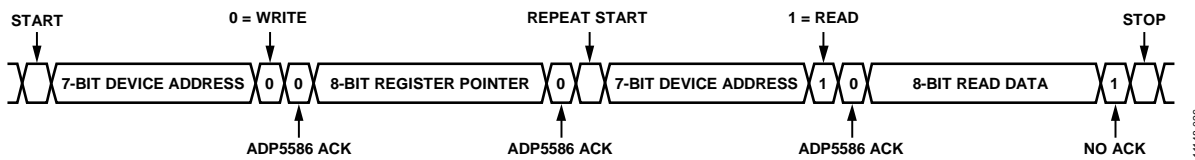

Figure 26. I<sup>2</sup>C Single Byte Read Sequence

Figure 27 shows a typical multibyte read sequence for reading internal registers. The cycle begins with a start condition followed by the 7-bit device address (0x34), followed by the R/W bit set to 0 for a write cycle. The ADP5586 acknowledges the address byte by pulling the data line low. The address of the register from which data is to be read is sent next. The ADP5586 acknowledges the register pointer byte by pulling the data line low. A start condition is repeated, followed by the 7-bit device address (0x34),

followed by the R/W bit set to 1 for a read cycle. The ADP5586 acknowledges the address byte by pulling the data line low. Next, the 8-bit data is then read. The address pointer is then incremented to read the next data byte, and the host continues to pull the data line low for each byte (master acknowledge) until the n data byte is read. The host pulls the data line high (no acknowledge) after the last byte is read, and a stop condition completes the sequence.



Figure 27. I<sup>2</sup>C Multibyte Read Sequence

11148-027

## REGISTER MAP

Table 7.

Reg Addr	Register Name	R/W <sup>1</sup>	Bit 7	Bit 6	Bit 5	Bit 4	Bit 3	Bit 2	Bit 1	Bit 0
0x00	ID	R	MAN_ID				REV_ID			
0x01	INT_STATUS	R/W	Reserved			LOGIC_INT	Reserved	OVRFLOW_INT	GPI_INT	EVENT_INT
0x02	Status	R	Reserved	LOGIC_STAT	Reserved	EC[4:0]				
0x03	FIFO_1	R	EVENT1_STATE	EVENT1_IDENTIFIER[6:0]						
0x04	FIFO_2	R	EVENT2_STATE	EVENT2_IDENTIFIER[6:0]						
0x05	FIFO_3	R	EVENT3_STATE	EVENT3_IDENTIFIER[6:0]						
0x06	FIFO_4	R	EVENT4_STATE	EVENT4_IDENTIFIER[6:0]						
0x07	FIFO_5	R	EVENT5_STATE	EVENT5_IDENTIFIER[6:0]						
0x08	FIFO_6	R	EVENT6_STATE	EVENT6_IDENTIFIER[6:0]						
0x09	FIFO_7	R	EVENT7_STATE	EVENT7_IDENTIFIER[6:0]						
0x0A	FIFO_8	R	EVENT8_STATE	EVENT8_IDENTIFIER[6:0]						
0x0B	FIFO_9	R	EVENT9_STATE	EVENT9_IDENTIFIER[6:0]						
0x0C	FIFO_10	R	EVENT10_STATE	EVENT10_IDENTIFIER[6:0]						
0x0D	FIFO_11	R	EVENT11_STATE	EVENT11_IDENTIFIER[6:0]						
0x0E	FIFO_12	R	EVENT12_STATE	EVENT12_IDENTIFIER[6:0]						
0x0F	FIFO_13	R	EVENT13_STATE	EVENT13_IDENTIFIER[6:0]						
0x10	FIFO_14	R	EVENT14_STATE	EVENT14_IDENTIFIER[6:0]						
0x11	FIFO_15	R	EVENT15_STATE	EVENT15_IDENTIFIER[6:0]						
0x12	FIFO_16	R	EVENT16_STATE	EVENT16_IDENTIFIER[6:0]						
0x13	GPI_INT_STAT_A	R	Reserved		GPI_6_INT	GPI_5_INT	GPI_4_INT	GPI_3_INT	GPI_2_INT	GPI_1_INT
0x14	GPI_INT_STAT_B	R	Reserved			GPI_11_INT	GPI_10_INT	GPI_9_INT	GPI_8_INT	GPI_7_INT
0x15	GPI_STATUS_A	R	Reserved		GPI_6_STAT	GPI_5_STAT	GPI_4_STAT	GPI_3_STAT	GPI_2_STAT	GPI_1_STAT
0x16	GPI_STATUS_B	R	Reserved			GPI_11_STAT	GPI_10_STAT	GPI_9_STAT	GPI_8_STAT	GPI_7_STAT
0x17	R_PULL_CONFIG_A	R/W	R3_PULL_CFG		R2_PULL_CFG		R1_PULL_CFG		R0_PULL_CFG	
0x18	R_PULL_CONFIG_B	R/W	Reserved				R5_PULL_CFG		R4_PULL_CFG	
0x19	R_PULL_CONFIG_C	R/W	C3_PULL_CFG		C2_PULL_CFG		C1_PULL_CFG		C0_PULL_CFG	
0x1A	R_PULL_CONFIG_D	R/W	Reserved						C4_PULL_CFG	
0x1B	GPI_INT_LEVEL_A	R/W	Reserved		GPI_6_INT_LEVEL	GPI_5_INT_LEVEL	GPI_4_INT_LEVEL	GPI_3_INT_LEVEL	GPI_2_INT_LEVEL	GPI_1_INT_LEVEL
0x1C	GPI_INT_LEVEL_B	R/W	Reserved			GPI_11_INT_LEVEL	GPI_10_INT_LEVEL	GPI_9_INT_LEVEL	GPI_8_INT_LEVEL	GPI_7_INT_LEVEL
0x1D	GPI_EVENT_EN_A	R/W	Reserved		GPI_6_EVENT_EN	GPI_5_EVENT_EN	GPI_4_EVENT_EN	GPI_3_EVENT_EN	GPI_2_EVENT_EN	GPI_1_EVENT_EN
0x1E	GPI_EVENT_EN_B	R/W	Reserved			GPI_11_EVENT_EN	GPI_10_EVENT_EN	GPI_9_EVENT_EN	GPI_8_EVENT_EN	GPI_7_EVENT_EN
0x1F	GPI_INTERRUPT_EN_A	R/W	Reserved		GPI_6_INT_EN	GPI_5_INT_EN	GPI_4_INT_EN	GPI_3_INT_EN	GPI_2_INT_EN	GPI_1_INT_EN
0x20	GPI_INTERRUPT_EN_B	R/W	Reserved			GPI_11_INT_EN	GPI_10_INT_EN	GPI_9_INT_EN	GPI_8_INT_EN	GPI_7_INT_EN
0x21	DEBOUNCE_DIS_A	R/W	Reserved		GPI_6_DEB_DIS	GPI_5_DEB_DIS	GPI_4_DEB_DIS	GPI_3_DEB_DIS	GPI_2_DEB_DIS	GPI_1_DEB_DIS
0x22	DEBOUNCE_DIS_B	R/W	Reserved			GPI_11_DEB_DIS	GPI_10_DEB_DIS	GPI_9_DEB_DIS	GPI_8_DEB_DIS	GPI_7_DEB_DIS
0x23	GPO_DATA_OUT_A	R/W	Reserved		GPO_6_DATA	GPO_5_DATA	GPO_4_DATA	GPO_3_DATA	GPO_2_DATA	GPO_1_DATA
0x24	GPO_DATA_OUT_B	R/W	Reserved			GPO_11_DATA	GPO_10_DATA	GPO_9_DATA	GPO_8_DATA	GPO_7_DATA
0x25	GPO_OUT_MODE_A	R/W	Reserved		GPO_6_OUT_MODE	GPO_5_OUT_MODE	GPO_4_OUT_MODE	GPO_3_OUT_MODE	GPO_2_OUT_MODE	GPO_1_OUT_MODE
0x26	GPO_OUT_MODE_B	R/W	Reserved			GPO_11_OUT_MODE	GPO_10_OUT_MODE	GPO_9_OUT_MODE	GPO_8_OUT_MODE	GPO_7_OUT_MODE
0x27	GPIO_OUT_EN_A	R/W	Reserved		GPIO_6_OUT_EN	GPIO_5_OUT_EN	GPIO_4_OUT_EN	GPIO_3_OUT_EN	GPIO_2_OUT_EN	GPIO_1_OUT_EN
0x28	GPIO_OUT_EN_B	R/W	Reserved			GPIO_11_OUT_EN	GPIO_10_OUT_EN	GPIO_9_OUT_EN	GPIO_8_OUT_EN	GPIO_7_OUT_EN

Reg Addr	Register Name	R/W <sup>1</sup>	Bit 7	Bit 6	Bit 5	Bit 4	Bit 3	Bit 2	Bit 1	Bit 0
0x29	GPIO_INP_EN_A	R/W	Reserved		GPIO_6_INP_EN	GPIO_5_INP_EN	GPIO_4_INP_EN	GPIO_3_INP_EN	GPIO_2_INP_EN	GPIO_1_INP_EN
0x2A	GPIO_INP_EN_B	R/W	Reserved			GPIO_11_INP_EN	GPIO_10_INP_EN	GPIO_9_INP_EN	GPIO_8_INP_EN	GPIO_7_INP_EN
0x2B	RESET_EVENT_A	R/W	RESET_EVENT_A_LEVEL	RESET_EVENT_A, Bits[6:0]						
0x2C	RESET_EVENT_B	R/W	RESET_EVENT_B_LEVEL	RESET_EVENT_B, Bits[6:0]						
0x2D	RESET_EVENT_C	R/W	RESET_EVENT_C_LEVEL	RESET_EVENT_C, Bits[6:0]						
0x2E	RESET_CFG	R/W	RESET_POL	RST_PASSTHRU_EN	RESET_TRIG_TIME, Bits[3:0]				RESET_PULSE_WIDTH, Bits[1:0]	
0x2F	PULSE_GEN_1_DELAY	R/W	PULSE_GEN_1_DELAY, Bits[7:0]							
0x30	PULSE_GEN_1_PERIOD	R/W	PULSE_GEN_1_PERIOD, Bits[7:0]							
0x31	PULSE_GEN_1_ON_TIME	R/W	PULSE_GEN_1_ON_TIME, Bits[7:0]							
0x32	PULSE_GEN_2_DELAY	R/W	PULSE_GEN_2_DELAY, Bits[7:0]							
0x33	PULSE_GEN_2_PERIOD	R/W	PULSE_GEN_2_PERIOD, Bits[7:0]							
0x34	PULSE_GEN_2_ON_TIME	R/W	PULSE_GEN_2_ON_TIME, Bits[7:0]							
0x35	PULSE_GEN_CONFIG	R/W	PULSE_GEN_1_INV	PULSE_GEN_1_ON_CLK	PULSE_GEN_1_PRD_CLK	PULSE_GEN_1_EN	PULSE_GEN_2_INV	PULSE_GEN_2_ON_CLK	PULSE_GEN_2_PRD_CLK	PULSE_GEN_2_EN
0x36	LOGIC_CFG	R/W	Reserved	LY_INV	LC_INV	LB_INV	LA_INV	LOGIC_SEL, Bits[2:0]		
0x37	LOGIC_FF_CFG	R/W	Reserved						FF_SET	FF_CLR
0x38	LOGIC_INT_EVENT_EN	R/W	Reserved					LY_DBNC_DIS	LOGIC_EVENT_EN	LOGIC_INT_LEVEL
0x39	POLL_TIME_CFG	R/W	Reserved				PRECHARGE_TIME	Reserved	KEY_POLL_TIME, Bits[1:0]	
0x3A	PIN_CONFIG_A	R/W	Reserved		R5_CONFIG	R4_CONFIG	R3_CONFIG	R2_CONFIG	R1_CONFIG	R0_CONFIG
0x3B	PIN_CONFIG_B	R/W	Reserved			C4_CONFIG	C3_CONFIG	C2_CONFIG	C1_CONFIG	C0_CONFIG
0x3C	PIN_CONFIG_C	R/W	PULL_SELECT	CO_EXTEND_CFG	R4_EXTEND_CFG	C1_EXTEND_CFG	R3_EXTEND_CFG	Reserved		R0_EXTEND_CFG
0x3D	GENERAL_CFG	R/W	OSC_EN	OSC_FREQ, Bits[1:0]		Reserved		SW_RESET	INT_CFG	RST_CFG
0x3E	INT_EN	R/W	Reserved			LOGIC_IEN	Reserved	OVRFLOW_IEN	GPI_IEN	EVENT_IEN

<sup>1</sup> R means read, W means write, and R/W means read/write.

**DETAILED REGISTER DESCRIPTIONS**

Note that all registers default to 0000 0000, unless otherwise specified.

**ID, Register 0x00**

Default: 0011 XXXX (where X = don't care)

**Table 8. ID Bit Descriptions**

Bits	Bit Name	Access	Description
[7:4]	MAN_ID	Read only	Manufacturer ID, default = 0011
[3:0]	REV_ID	Read only	Revision ID

**INT\_STATUS, Register 0x01****Table 9. INT\_STATUS Bit Descriptions**

Bits	Bit Name	Access	Description <sup>1</sup>
[7:5]	Reserved	Reserved	Reserved.
4	LOGIC_INT	Read/write	0 = no interrupt. 1 = interrupt due to a general logic condition.
3	Reserved	Reserved	Reserved.
2	OVERFLOW_INT	Read/write	0 = no interrupt. 1 = interrupt due to an overflow condition.
1	GPI_INT	Read/write	This bit is not set by a GPI that has been configured to update the FIFO and event count. This bit cannot be cleared until all GPI_x_INT bits are cleared. 0 = no interrupt. 1 = interrupt due to a general GPI condition.
0	EVENT_INT	Read/write	0 = no interrupt. 1 = interrupt due to key event (press/release), GPI event (GPI programmed for FIFO updates), or logic event (programmed for FIFO updates).

<sup>1</sup> Interrupt bits are cleared by writing a 1 to the flag; writing a 0 or reading the flag has no effect.

**Status, Register 0x02****Table 10. Status Bit Descriptions**

Bits	Bit Name	Access	Description
7	Reserved	Reserved	Reserved.
6	LOGIC_STAT	Read only	0 = output from logic block (LY) is low. 1 = output from logic block (LY) is high.
5	Reserved	Reserved	Reserved.
[4:0]	EC[4:0]	Read only	Event count value. Indicates how many events are currently stored on the FIFO.

**FIFO\_1, Register 0x03****Table 11. FIFO\_1 Bit Descriptions**

Bits	Bit Name	Access	Description
7	EVENT1_STATE	Read only	This bit represents the state of the event that is recorded in the EVENT1_IDENTIFIER[6:0] bits. For key events from Event 1 to Event 36, use the following settings: 1 = key is pressed. 0 = key is released. For GPI and logic events from Event 37 to Event 48, use the following settings: 1 = GPI/logic is active. 0 = GPI/logic is inactive. Active and inactive states for Event 37 to Event 48 are programmable.
[6:0]	EVENT1_IDENTIFIER[6:0]	Read only	Contains the event identifier for the pin. See Table 12 for event decoding information.

Table 12. Event Decoding

Event No.	Meaning	Event No.	Meaning
0	No event	25	Key 25 (R4, C4)
1	Key 1 (R0, C0)	26	Key 26 (R5, C0)
2	Key 2 (R0, C1)	27	Key 27 (R5, C1)
3	Key 3 (R0, C2)	28	Key 28 (R5, C2)
4	Key 4 (R0, C3)	29	Key 29 (R5, C3)
5	Key 5 (R0, C4)	30	Key 30 (R5, C4)
6	Key 6 (R1, C0)	31	Key 31 (R0, GND)
7	Key 7 (R1, C1)	32	Key 32 (R1, GND)
8	Key 8 (R1, C2)	33	Key 33 (R2, GND)
9	Key 9 (R1, C3)	34	Key 34 (R3, GND)
10	Key 10 (R1, C4)	35	Key 35 (R4, GND)
11	Key 11 (R2, C0)	36	Key 36 (R5, GND)
12	Key 12 (R2, C1)	37	GPI 1 (R0)
13	Key 13 (R2, C2)	38	GPI 2 (R1)
14	Key 14 (R2, C3)	39	GPI 3 (R2)
15	Key 15 (R2, C4)	40	GPI 4 (R3)
16	Key 16 (R3, C0)	41	GPI 5 (R4)
17	Key 17 (R3, C1)	42	GPI 6 (R5)
18	Key 18 (R3, C2)	43	GPI 7 (C0)
19	Key 19 (R3, C3)	44	GPI 8 (C1)
20	Key 20 (R3, C4)	45	GPI 9 (C2)
21	Key 21 (R4, C0)	46	GPI 10 (C3)
22	Key 22 (R4, C1)	47	GPI 11 (C4)
23	Key 23 (R4, C2)	48	Logic
24	Key 24 (R4, C3)	49 to 127	Unused

**FIFO\_2, Register 0x04**

Table 13. FIFO\_2 Bit Descriptions

Bits	Bit Name	Access	Description
7	EVENT2_STATE	Read only	See Table 11 for bit descriptions.
[6:0]	EVENT2_IDENTIFIER[6:0]	Read only	See Table 11 for bit descriptions.

**FIFO\_3, Register 0x05**

Table 14. FIFO\_3 Bit Descriptions

Bits	Bit Name	Access	Description
7	EVENT3_STATE	Read only	See Table 11 for bit descriptions.
[6:0]	EVENT3_IDENTIFIER[6:0]	Read only	See Table 11 for bit descriptions.

**FIFO\_4, Register 0x06**

Table 15. FIFO\_4 Bit Descriptions

Bits	Bit Name	Access	Description
7	EVENT4_STATE	Read only	See Table 11 for bit descriptions.
[6:0]	EVENT4_IDENTIFIER[6:0]	Read only	See Table 11 for bit descriptions.

**FIFO\_5, Register 0x07**

Table 16. FIFO\_5 Bit Descriptions

Bits	Bit Name	Access	Description
7	EVENT5_STATE	Read only	See Table 11 for bit descriptions.
[6:0]	EVENT5_IDENTIFIER[6:0]	Read only	See Table 11 for bit descriptions.

**FIFO\_6 Register 0x08**

Table 17. FIFO\_6 Bit Descriptions

Bits	Bit Name	Access	Description
7	EVENT6_STATE	Read only	See Table 11 for bit descriptions.
[6:0]	EVENT6_IDENTIFIER[6:0]	Read only	See Table 11 for bit descriptions.

**FIFO\_7, Register 0x09**

Table 18. FIFO\_7 Bit Descriptions

Bits	Bit Name	Access	Description
7	EVENT7_STATE	Read only	See Table 11 for bit descriptions.
[6:0]	EVENT7_IDENTIFIER[6:0]	Read only	See Table 11 for bit descriptions.

**FIFO\_8, Register 0x0A**

Table 19. FIFO\_8 Bit Descriptions

Bits	Bit Name	Access	Description
7	EVENT8_STATE	Read only	See Table 11 for bit descriptions.
[6:0]	EVENT8_IDENTIFIER[6:0]	Read only	See Table 11 for bit descriptions.

**FIFO\_9, Register 0x0B**

Table 20. FIFO\_9 Bit Descriptions

Bits	Bit Name	Access	Description
7	EVENT9_STATE	Read only	See Table 11 for bit descriptions.
[6:0]	EVENT9_IDENTIFIER[6:0]	Read only	See Table 11 for bit descriptions.

**FIFO\_10, Register 0x0C**

Table 21. FIFO\_10 Bit Descriptions

Bits	Bit Name	Access	Description
7	EVENT10_STATE	Read only	See Table 11 for bit descriptions.
[6:0]	EVENT10_IDENTIFIER[6:0]	Read only	See Table 11 for bit descriptions.

**FIFO\_11, Register 0x0D**

Table 22. FIFO\_11 Bit Descriptions

Bits	Bit Name	Access	Description
7	EVENT11_STATE	Read only	See Table 11 for bit descriptions.
[6:0]	EVENT11_IDENTIFIER[6:0]	Read only	See Table 11 for bit descriptions.

**FIFO\_12, Register 0x0E**

Table 23. FIFO\_12 Bit Descriptions

Bits	Bit Name	Access	Description
7	EVENT12_STATE	Read only	See Table 11 for bit descriptions.
[6:0]	EVENT12_IDENTIFIER[6:0]	Read only	See Table 11 for bit descriptions.

**FIFO\_13, Register 0x0F**

Table 24. FIFO\_13 Bit Descriptions

Bits	Bit Name	Access	Description
7	EVENT13_STATE	Read only	See Table 11 for bit descriptions.
[6:0]	EVENT13_IDENTIFIER[6:0]	Read only	See Table 11 for bit descriptions.

**FIFO\_14, Register 0x10**

Table 25. FIFO\_14 Bit Descriptions

Bits	Bit Name	Access	Description
7	EVENT14_STATE	Read only	See Table 11 for bit descriptions.
[6:0]	EVENT14_IDENTIFIER[6:0]	Read only	See Table 11 for bit descriptions.

**FIFO\_15, Register 0x11**

Table 26. FIFO\_15 Bit Descriptions

Bits	Bit Name	Access	Description
7	EVENT15_STATE	Read only	See Table 11 for bit descriptions.
[6:0]	EVENT15_IDENTIFIER[6:0]	Read only	See Table 11 for bit descriptions.

**FIFO\_16, Register 0x12**

Table 27. FIFO\_16 Bit Descriptions

Bits	Bit Name	Access	Description
7	EVENT16_STATE	Read only	See Table 11 for bit descriptions.
[6:0]	EVENT16_IDENTIFIER[6:0]	Read only	See Table 11 for bit descriptions.

**GPI\_INT\_STAT\_A, Register 0x13**

Table 28. GPI\_INT\_STAT\_A Bit Descriptions

Bits	Bit Name	Access	Description
[7:6]	Reserved	Reserved	Reserved.
5	GPI_6_INT	Read only	0 = no interrupt 1 = interrupt due to GPI 6 (R5 pin). Cleared on read.
4	GPI_5_INT	Read only	0 = no interrupt 1 = interrupt due to GPI 5 (R4 pin). Cleared on read.
3	GPI_4_INT	Read only	0 = no interrupt 1 = interrupt due to GPI 4 (R3 pin). Cleared on read.
2	GPI_3_INT	Read only	0 = no interrupt 1 = interrupt due to GPI 3 (R2 pin). Cleared on read.
1	GPI_2_INT	Read only	0 = no interrupt 1 = interrupt due to GPI 2 (R1 pin). Cleared on read.
0	GPI_1_INT	Read only	0 = no interrupt 1 = interrupt due to GPI 1 (R0 pin). Cleared on read.

**GPI\_INT\_STAT\_B, Register 0x14**

Table 29. GPI\_INT\_STAT\_B Bit Descriptions

Bits	Bit Name	Access	Description
[7:5]	Reserved	Reserved	Reserved.
4	GPI_11_INT	Read only	0 = no interrupt. 1 = interrupt due to GPI 11 (C4 pin). Cleared on read.
3	GPI_10_INT	Read only	0 = no interrupt. 1 = interrupt due to GPI 10 (C3 pin). Cleared on read.
2	GPI_9_INT	Read only	0 = no interrupt. 1 = interrupt due to GPI 9 (C2 pin). Cleared on read.
1	GPI_8_INT	Read only	0 = no interrupt. 1 = interrupt due to GPI 8 (C1 pin). Cleared on read.
0	GPI_7_INT	Read only	0 = no interrupt. 1 = interrupt due to GPI 7 (C0 pin). Cleared on read.



**GPI\_STATUS\_A, Register 0x15****Table 30. GPI\_STATUS\_A Bit Descriptions**

Bits	Bit Name	Access	Description
[7:6]	Reserved	Reserved	Reserved.
5	GPI_6_STAT	Read only	0 = GPI 6 (R5 pin) is low. 1 = GPI 6 (R5 pin) is high.
4	GPI_5_STAT	Read only	0 = GPI 5 (R4 pin) is low. 1 = GPI 5 (R4 pin) is high.
3	GPI_4_STAT	Read only	0 = GPI 4 (R3 pin) is low. 1 = GPI 4 (R3 pin) is high.
2	GPI_3_STAT	Read only	0 = GPI 3 (R2 pin) is low. 1 = GPI 3 (R2 pin) is high.
1	GPI_2_STAT	Read only	0 = GPI 2 (R1 pin) is low. 1 = GPI 2 (R1 pin) is high.
0	GPI_1_STAT	Read only	0 = GPI 1 (R0 pin) is low. 1 = GPI 1 (R0 pin) is high.

**GPI\_STATUS\_B, Register 0x16****Table 31. GPI\_STATUS\_B Bit Descriptions**

Bits	Bit Name	Access	Description
[7:5]	Reserved	Reserved	Reserved.
4	GPI_11_STAT	Read only	0 = GPI 11 (C4 pin) is low. 1 = GPI 11 (C4 pin) is high.
3	GPI_10_STAT	Read only	0 = GPI 10 (C3 pin) is low. 1 = GPI 10 (C3 pin) is high.
2	GPI_9_STAT	Read only	0 = GPI 9 (C2 pin) is low. 1 = GPI 9 (C2 pin) is high.
1	GPI_8_STAT	Read only	0 = GPI 8 (C1 pin) is low. 1 = GPI 8 (C1 pin) is high.
0	GPI_7_STAT	Read only	0 = GPI 7 (C0 pin) is low. 1 = GPI 7 (C0 pin) is high.

**R\_PULL\_CONFIG\_A, Register 0x17**

Default = 0101 0101

**Table 32. R\_PULL\_CONFIG\_A Bit Descriptions**

Bits	Bit Name	Access	Description
[7:6]	R3_PULL_CFG	Read/write	00 = enables 300 kΩ pull-up resistor. 01 = enables 300 kΩ pull-down resistor. 10 = enables 100 kΩ pull-up resistor. 11 = disables all pull-up/pull-down resistors.
[5:4]	R2_PULL_CFG	Read/write	00 = enables 300 kΩ pull-up resistor. 01 = enables 300 kΩ pull-down resistor. 10 = enables 100 kΩ pull-up resistor. 11 = disables all pull-up/pull-down resistors.
[3:2]	R1_PULL_CFG	Read/write	00 = enables 300 kΩ pull-up resistor. 01 = enables 300 kΩ pull-down resistor. 10 = enables 100 kΩ pull-up resistor. 11 = disables all pull-up/pull-down resistors.
[1:0]	R0_PULL_CFG	Read/write	00 = enables 300 kΩ pull-up resistor. 01 = enables 300 kΩ pull-down resistor. 10 = enables 100 kΩ pull-up resistor. 11 = disables all pull-up/pull-down resistors.

**R\_PULL\_CONFIG\_B, Register 0x18**

Default = 0000 0101

**Table 33. R\_PULL\_CONFIG\_B Bit Descriptions**

Bits	Bit Name	Access	Description
[7:4]	Reserved	Reserved	Reserved.
[3:2]	R5_PULL_CFG	Read/write	Reserved except for the ADP5586ACBZ-01-R7 options. 00 = enables 300 kΩ pull-up resistor. 01 = enables 300 kΩ pull-down resistor. 10 = enables 100 kΩ pull-up resistor. 11 = disables all pull-up/pull-down resistors.
[1:0]	R4_PULL_CFG	Read/write	00 = enables 300 kΩ pull-up resistor. 01 = enables 300 kΩ pull-down resistor. 10 = enables 100 kΩ pull-up resistor. 11 = disables all pull-up/pull-down resistors.

**R\_PULL\_CONFIG\_C, Register 0x19**

Default = 0101 0001

**Table 34. R\_PULL\_CONFIG\_C Bit Descriptions**

Bits	Bit Name	Access	Description
[7:6]	C3_PULL_CFG	Read/write	00 = enables 300 kΩ pull-up resistor. 01 = enables 300 kΩ pull-down resistor. 10 = enables 100 kΩ pull-up resistor. 11 = disables all pull-up/pull-down resistors.
[5:4]	C2_PULL_CFG	Read/write	00 = enables 300 kΩ pull-up resistor. 01 = enables 300 kΩ pull-down resistor. 10 = enables 100 kΩ pull-up resistor. 11 = disables all pull-up/pull-down resistors.
[3:2]	C1_PULL_CFG	Read/write	00 = enables 300 kΩ pull-up resistor. 01 = enables 300 kΩ pull-down resistor. 10 = enables 100 kΩ pull-up resistor. 11 = disables all pull-up/pull-down resistors.
[1:0]	C0_PULL_CFG	Read/write	00 = enables 300 kΩ pull-up resistor. 01 = enables 300 kΩ pull-down resistor. 10 = enables 100 kΩ pull-up resistor. 11 = disables all pull-up/pull-down resistors.

**R\_PULL\_CONFIG\_D, Register 0x1A**

Default = 0000 0001

**Table 35. R\_PULL\_CONFIG\_D Bit Descriptions**

Bits	Bit Name	Access	Description
[7:2]	Reserved	Reserved	Reserved.
[1:0]	C4_PULL_CFG	Read/write	00 = enables 300 kΩ pull-up resistor. 01 = enables 300 kΩ pull-down resistor. 10 = enables 100 kΩ pull-up resistor. 11 = disables all pull-up/pull-down resistors.

**GPI\_INT\_LEVEL\_A, Register 0x1B****Table 36. GPI\_INT\_LEVEL\_A Bit Descriptions**

Bits	Bit Name	Access	Description
[7:6]	Reserved	Reserved	Reserved.
5	GPI_6_INT_LEVEL	Read/write	0 = GPI 6 interrupt is active low (GPI_6_INT sets whenever R5 is low). 1 = GPI 6 interrupt is active high (GPI_6_INT sets whenever R5 is high).
4	GPI_5_INT_LEVEL	Read/write	0 = GPI 5 interrupt is active low (GPI_5_INT sets whenever R4 is low). 1 = GPI 5 interrupt is active high (GPI_5_INT sets whenever R4 is high).
3	GPI_4_INT_LEVEL	Read/write	0 = GPI 4 interrupt is active low (GPI_4_INT sets whenever R3 is low). 1 = GPI 4 interrupt is active high (GPI_4_INT sets whenever R3 is high).
2	GPI_3_INT_LEVEL	Read/write	0 = GPI 3 interrupt is active low (GPI_3_INT sets whenever R2 is low). 1 = GPI 3 interrupt is active high (GPI_3_INT sets whenever R2 is high).
1	GPI_2_INT_LEVEL	Read/write	0 = GPI 2 interrupt is active low (GPI_2_INT sets whenever R1 is low). 1 = GPI 2 interrupt is active high (GPI_2_INT sets whenever R1 is high).
0	GPI_1_INT_LEVEL	Read/write	0 = GPI 1 interrupt is active low (GPI_1_INT sets whenever R0 is low). 1 = GPI 1 interrupt is active high (GPI_1_INT sets whenever R0 is high).

**GPI\_INT\_LEVEL\_B, Register 0x1C****Table 37. GPI\_INT\_LEVEL\_B Bit Descriptions**

Bits	Bit Name	Access	Description
[7:5]	Reserved	Reserved	Reserved.
4	GPI_11_INT_LEVEL	Read/write	0 = GPI 11 interrupt is active low (GPI_11_INT sets whenever R10 is low). 1 = GPI 11 interrupt is active high (GPI_11_INT sets whenever R10 is high).
3	GPI_10_INT_LEVEL	Read/write	0 = GPI 10 interrupt is active low (GPI_10_INT sets whenever R9 is low). 1 = GPI 10 interrupt is active high (GPI_10_INT sets whenever R9 is high).
2	GPI_9_INT_LEVEL	Read/write	0 = GPI 9 interrupt is active low (GPI_9_INT sets whenever R8 is low). 1 = GPI 9 interrupt is active high (GPI_9_INT sets whenever R8 is high).
1	GPI_8_INT_LEVEL	Read/write	0 = GPI 8 interrupt is active low (GPI_8_INT sets whenever R7 is low). 1 = GPI 8 interrupt is active high (GPI_8_INT sets whenever R7 is high).
0	GPI_7_INT_LEVEL	Read/write	0 = GPI 7 interrupt is active low (GPI_7_INT sets whenever R6 is low). 1 = GPI 7 interrupt is active high (GPI_7_INT sets whenever R6 is high).

**GPI\_EVENT\_EN\_A, Register 0x1D****Table 38. GPI\_EVENT\_EN\_A Bit Descriptions**

Bits	Bit Name	Access	Description
[7:6]	Reserved	Reserved	Reserved.
5	GPI_6_EVENT_EN	Read/write	0 = disables GPI events from GPI 6. 1 = allows GPI 6 activity to generate events on the FIFO. <sup>1</sup>
4	GPI_5_EVENT_EN	Read/write	0 = disables GPI events from GPI 5. 1 = allows GPI 5 activity to generate events on the FIFO. <sup>1</sup>
3	GPI_4_EVENT_EN	Read/write	0 = disables GPI events from GPI 4. 1 = allows GPI 4 activity to generate events on the FIFO. <sup>1</sup>
2	GPI_3_EVENT_EN	Read/write	0 = disables GPI events from GPI 3. 1 = allows GPI 3 activity to generate events on the FIFO. <sup>1</sup>
1	GPI_2_EVENT_EN	Read/write	0 = disables GPI events from GPI 2. 1 = allows GPI 2 activity to generate events on the FIFO. <sup>1</sup>
0	GPI_1_EVENT_EN	Read/write	0 = disables GPI events from GPI 1. 1 = allows GPI 1 activity to generate events on the FIFO. <sup>1</sup>

<sup>1</sup> GPIs in this mode are considered FIFO events and can be used for unlock purposes. GPI activity in this mode causes EVENT\_INT interrupts. GPIs in this mode do not generate GPI\_INT interrupts.

**GPI\_EVENT\_EN\_B, Register 0x1E****Table 39. GPI\_EVENT\_EN\_B Bit Descriptions**

Bits	Bit Name	Access	Description
[7:5]	Reserved	Reserved	Reserved.
4	GPI_11_EVENT_EN	Read/write	0 = disables GPI events from GPI 11. 1 = allows GPI 11 activity to generate events on the FIFO. <sup>1</sup>
3	GPI_10_EVENT_EN	Read/write	0 = disables GPI events from GPI 10. 1 = allows GPI 10 activity to generate events on the FIFO. <sup>1</sup>
2	GPI_9_EVENT_EN	Read/write	0 = disables GPI events from GPI 9. 1 = allows GPI 9 activity to generate events on the FIFO. <sup>1</sup>
1	GPI_8_EVENT_EN	Read/write	0 = disables GPI events from GPI 8. 1 = allows GPI 8 activity to generate events on the FIFO. <sup>1</sup>
0	GPI_7_EVENT_EN	Read/write	0 = disables GPI events from GPI 7. 1 = allows GPI 7 activity to generate events on the FIFO. <sup>1</sup>

<sup>1</sup> GPIs in this mode are considered FIFO events and can be used for unlock purposes. GPI activity in this mode causes EVENT\_INT interrupts. GPIs in this mode do not generate GPI\_INT interrupts.

**GPI\_INTERRUPT\_EN\_A, Register 0x1F****Table 40. GPI\_INTERRUPT\_EN\_A Bit Descriptions**

Bits	Bit Name	Access	Description
[7:6]	Reserved	Reserved	Reserved.
5	GPI_6_INT_EN	Read/write	0 = GPI_6_INT is disabled. 1 = GPI_6_INT enabled. Asserts the GPI_INT bit (Register 0x01, Bit 1) if GPI_6_INT is set and the GPI 6 interrupt condition is met.
4	GPI_5_INT_EN	Read/write	0 = GPI_5_INT is disabled. 1 = GPI_5_INT enabled. Asserts the GPI_INT bit (Register 0x01, Bit 1) if GPI_5_INT is set and the GPI 5 interrupt condition is met.
3	GPI_4_INT_EN	Read/write	0 = GPI_4_INT is disabled. 1 = GPI_4_INT enabled. Asserts the GPI_INT bit (Register 0x01, Bit 1) if GPI_4_INT is set and the GPI 4 interrupt condition is met.
2	GPI_3_INT_EN	Read/write	0 = GPI_3_INT is disabled. 1 = GPI_3_INT enabled. Asserts the GPI_INT bit (Register 0x01, Bit 1) if GPI_3_INT is set and the GPI 3 interrupt condition is met.
1	GPI_2_INT_EN	Read/write	0 = GPI_2_INT is disabled. 1 = GPI_2_INT enabled. Asserts the GPI_INT bit (Register 0x01, Bit 1) if GPI_2_INT is set and the GPI 2 interrupt condition is met.
0	GPI_1_INT_EN	Read/write	0 = GPI_1_INT is disabled. 1 = GPI_1_INT enabled. Asserts the GPI_INT bit (Register 0x01, Bit 1) if GPI_1_INT is set and the GPI 1 interrupt condition is met.

**GPI\_INTERRUPT\_EN\_B, Register 0x20****Table 41. GPI\_INTERRUPT\_EN\_B Bit Descriptions**

Bits	Bit Name	Access	Description
[7:5]	Reserved	Reserved	Reserved.
4	GPI_11_INT_EN	Read/write	0 = GPI_11_INT is disabled. 1 = GPI_11_INT enabled. Asserts the GPI_INT bit (Register 0x01, Bit 1) if GPI_11_INT is set and the GPI 11 interrupt condition is met.
3	GPI_10_INT_EN	Read/write	0 = GPI_10_INT is disabled. 1 = GPI_10_INT enabled. Asserts the GPI_INT bit (Register 0x01, Bit 1) if GPI_10_INT is set and the GPI 10 interrupt condition is met.
2	GPI_9_INT_EN	Read/write	0 = GPI_9_INT is disabled. 1 = GPI_9_INT enabled. Asserts the GPI_INT bit (Register 0x01, Bit 1) if GPI_9_INT is set and the GPI 9 interrupt condition is met.
1	GPI_8_INT_EN	Read/write	0 = GPI_8_INT is disabled. 1 = GPI_8_INT enabled. Asserts the GPI_INT bit (Register 0x01, Bit 1) if GPI_8_INT is set and the GPI 8 interrupt condition is met.
0	GPI_7_INT_EN	Read/write	0 = GPI_7_INT is disabled. 1 = GPI_7_INT enabled. Asserts the GPI_INT bit (Register 0x01, Bit 1) if GPI_7_INT is set and the GPI 7 interrupt condition is met.

**DEBOUNCE\_DIS\_A, Register 0x21****Table 42. DEBOUNCE\_DIS\_A Bit Descriptions**

Bits	Bit Name	Access	Description
[7:6]	Reserved	Reserved	Reserved.
5	GPI_6_DEB_DIS	Read/write	0 = debounce enabled on GPI 6. 1 = debounce disabled on GPI 6.
4	GPI_5_DEB_DIS	Read/write	0 = debounce enabled on GPI 5. 1 = debounce disabled on GPI 5.
3	GPI_4_DEB_DIS	Read/write	0 = debounce enabled on GPI 4. 1 = debounce disabled on GPI 4.
2	GPI_3_DEB_DIS	Read/write	0 = debounce enabled on GPI 3. 1 = debounce disabled on GPI 3.
1	GPI_2_DEB_DIS	Read/write	0 = debounce enabled on GPI 2. 1 = debounce disabled on GPI 2.
0	GPI_1_DEB_DIS	Read/write	0 = debounce enabled on GPI 1. 1 = debounce disabled on GPI 1.

**DEBOUNCE\_DIS\_B, Register 0x22****Table 43. DEBOUNCE\_DIS\_B Bit Descriptions**

Bits	Bit Name	Access	Description
[7:5]	Reserved	Reserved	Reserved.
4	GPI_11_DEB_DIS	Read/write	0 = debounce enabled on GPI 11. 1 = debounce disabled on GPI 11.
3	GPI_10_DEB_DIS	Read/write	0 = debounce enabled on GPI 10. 1 = debounce disabled on GPI 10.
2	GPI_9_DEB_DIS	Read/write	0 = debounce enabled on GPI 9. 1 = debounce disabled on GPI 9.
1	GPI_8_DEB_DIS	Read/write	0 = debounce enabled on GPI 8. 1 = debounce disabled on GPI 8.
0	GPI_7_DEB_DIS	Read/write	0 = debounce enabled on GPI 7. 1 = debounce disabled on GPI 7.

**GPO\_DATA\_OUT\_A, Register 0x23****Table 44. GPO\_DATA\_OUT\_A Bit Descriptions**

Bits	Bit Name	Access	Description
[7:6]	Reserved	Reserved	Reserved.
5	GPO_6_DATA	Read/write	0 = sets output low. 1 = sets output high.
4	GPO_5_DATA	Read/write	0 = sets output low. 1 = sets output high.
3	GPO_4_DATA	Read/write	0 = sets output low. 1 = sets output high.
2	GPO_3_DATA	Read/write	0 = sets output low. 1 = sets output high.
1	GPO_2_DATA	Read/write	0 = sets output low. 1 = sets output high.
0	GPO_1_DATA	Read/write	0 = sets output low. 1 = sets output high.

**GPO\_DATA\_OUT\_B, Register 0x24**

Table 45. GPO\_DATA\_OUT\_B Bit Descriptions

Bits	Bit Name	Access	Description
[7:5]	Reserved	Reserved	Reserved.
4	GPO_11_DATA	Read/write	0 = sets output low. 1 = sets output high.
3	GPO_10_DATA	Read/write	0 = sets output low. 1 = sets output high.
2	GPO_9_DATA	Read/write	0 = sets output low. 1 = sets output high.
1	GPO_8_DATA	Read/write	0 = sets output low. 1 = sets output high.
0	GPO_7_DATA	Read/write	0 = sets output low. 1 = sets output high.

**GPO\_OUT\_MODE\_A, Register 0x25**

Table 46. GPO\_OUT\_MODE\_A Bit Descriptions

Bits	Bit Name	Access	Description
[7:6]	Reserved	Reserved	Reserved.
5	GPO_6_OUT_MODE	Read/write	0 = push-pull. 1 = open drain.
4	GPO_5_OUT_MODE	Read/write	0 = push-pull. 1 = open drain.
3	GPO_4_OUT_MODE	Read/write	0 = push-pull. 1 = open drain.
2	GPO_3_OUT_MODE	Read/write	0 = push-pull. 1 = open drain.
1	GPO_2_OUT_MODE	Read/write	0 = push-pull. 1 = open drain.
0	GPO_1_OUT_MODE	Read/write	0 = push-pull. 1 = open drain.

**GPO\_OUT\_MODE\_B, Register 0x26**

Table 47. GPO\_OUT\_MODE\_B Bit Descriptions

Bits	Bit Name	Access	Description
[7:5]	Reserved	Reserved	Reserved.
4	GPO_11_OUT_MODE	Read/write	0 = push-pull. 1 = open drain.
3	GPO_10_OUT_MODE	Read/write	0 = push-pull. 1 = open drain.
2	GPO_9_OUT_MODE	Read/write	0 = push-pull. 1 = open drain.
1	GPO_8_OUT_MODE	Read/write	0 = push-pull. 1 = open drain.
0	GPO_7_OUT_MODE	Read/write	0 = push-pull. 1 = open drain.

**GPIO\_OUT\_EN\_A, Register 0x27**

Table 48. GPIO\_OUT\_EN\_A Bit Descriptions

Bits	Bit Name	Access	Description
[7:6]	Reserved	Reserved	Reserved.
5	GPIO_6_OUT_EN	Read/write	0 = GPIO 6 output disabled. 1 = GPIO 6 output enabled.
4	GPIO_5_OUT_EN	Read/write	0 = GPIO 5 output disabled. 1 = GPIO 5 output enabled.
3	GPIO_4_OUT_EN	Read/write	0 = GPIO 4 output disabled. 1 = GPIO 4 output enabled.
2	GPIO_3_OUT_EN	Read/write	0 = GPIO 3 output disabled. 1 = GPIO 3 output enabled.
1	GPIO_2_OUT_EN	Read/write	0 = GPIO 2 output disabled. 1 = GPIO 2 output enabled.
0	GPIO_1_OUT_EN	Read/write	0 = GPIO 1 output disabled. 1 = GPIO 1 output enabled.

**GPIO\_OUT\_EN\_B, Register 0x28**

Table 49. GPIO\_OUT\_EN\_B Bit Descriptions

Bits	Bit Name	Access	Description
[7:5]	Reserved	Reserved	Reserved.
4	GPIO_11_OUT_EN	Read/write	0 = GPIO 11 output disabled. 1 = GPIO 11 output enabled.
3	GPIO_10_OUT_EN	Read/write	0 = GPIO 10 output disabled. 1 = GPIO 10 output enabled.
2	GPIO_9_OUT_EN	Read/write	0 = GPIO 9 output disabled. 1 = GPIO 9 output enabled.
1	GPIO_8_OUT_EN	Read/write	0 = GPIO 8 output disabled. 1 = GPIO 8 output enabled.
0	GPIO_7_OUT_EN	Read/write	0 = GPIO 7 output disabled. 1 = GPIO 7 output enabled.

**GPIO\_INP\_EN\_A, Register 0x29**

Table 50. GPIO\_INP\_EN\_A Bit Descriptions

Bits	Bit Name	Access	Description
[7:6]	Reserved	Reserved	Reserved.
5	GPIO_6_INP_EN	Read/write	0 = GPIO 6 input disabled. 1 = GPIO 6 input enabled.
4	GPIO_5_INP_EN	Read/write	0 = GPIO 5 input disabled. 1 = GPIO 5 input enabled.
3	GPIO_4_INP_EN	Read/write	0 = GPIO 4 input disabled. 1 = GPIO 4 input enabled.
2	GPIO_3_INP_EN	Read/write	0 = GPIO 3 input disabled. 1 = GPIO 3 input enabled.
1	GPIO_2_INP_EN	Read/write	0 = GPIO 2 input disabled. 1 = GPIO 2 input enabled.
0	GPIO_1_INP_EN	Read/write	0 = GPIO 1 input disabled. 1 = GPIO 1 input enabled.



**GPIO\_INP\_EN\_B, Register 0x2A**

Table 51. GPIO\_INP\_EN\_B Bit Descriptions

Bits	Bit Name	Access	Description
[7:5]	Reserved	Reserved	Reserved.
4	GPIO_11_INP_EN	Read/write	0 = GPIO 11 input disabled. 1 = GPIO 11 input enabled.
3	GPIO_10_INP_EN	Read/write	0 = GPIO 10 input disabled. 1 = GPIO 10 input enabled.
2	GPIO_9_INP_EN	Read/write	0 = GPIO 9 input disabled. 1 = GPIO 9 input enabled.
1	GPIO_8_INP_EN	Read/write	0 = GPIO 8 input disabled. 1 = GPIO 8 input enabled.
0	GPIO_7_INP_EN	Read/write	0 = GPIO 7 input disabled. 1 = GPIO 7 input enabled.

**RESET\_EVENT\_A, Register 0x2B**

Table 52. RESET\_EVENT\_A Bit Descriptions

Bits	Bit Name	Access	Description
7	RESET_EVENT_A_LEVEL	Read/write	Defines which level the first reset event should be to generate the RESET_OUT signal. For key events, use the following settings: 0 = inactive event used as a reset condition. 1 = active event used as a reset condition. For GPIOs and logic outputs configured for FIFO updates, use the following settings: 0 = not applicable; releases not used for reset generation. 1 = press is used as a reset event.
[6:0]	RESET_EVENT_A[6:0]	Read/write	Defines an event that can be used to generate the RESET_OUT signal. Up to three events can be defined for generating the RESET_OUT signal, using RESET_EVENT_A[6:0], RESET_EVENT_B[6:0], and RESET_EVENT_C[6:0]. If one of the registers is 0, that register is not used for reset generation. All reset events must be detected at the same time to trigger the reset.

**RESET\_EVENT\_B, Register 0x2C**

Table 53. RESET\_EVENT\_B Bit Descriptions

Bits	Bit Name	Access	Description
7	RESET_EVENT_B_LEVEL	Read/write	Defines which level the second reset event should be to generate the RESET_OUT signal. Refer to Table 52.
[6:0]	RESET_EVENT_B[6:0]	Read/write	Defines an event that can be used to generate the RESET_OUT signal. See Table 12.

**RESET\_EVENT\_C, Register 0x2D**

Table 54. RESET\_EVENT\_C Bit Descriptions

Bits	Bit Name	Access	Description
7	RESET_EVENT_C_LEVEL	Read/write	Defines which level the third reset event should be to generate the RESET_OUT signal. Refer to Table 52.
[6:0]	RESET_EVENT_C[6:0]	Read/write	Defines an event that can be used to generate the RESET_OUT signal. See Table 12.

**RESET\_CFG, Register 0x2E**

Table 55. RESET\_CFG Bit Descriptions

Bits	Bit Name	Access	Description
7	RESET_POL	Read/write	Sets the polarity of the RESET_OUT signal. 0 = RESET_OUT is active low. 1 = RESET_OUT is active high.
6	RST_PASSTHRU_EN	Read/write	Allows the $\overline{\text{RST}}$ pin to override (OR with) the RESET_OUT signal.
[5:2]	RESET_TRIG_TIME[3:0]	Read/write	Defines the length of time that the reset events must be active before a RESET_OUT signal is generated. All events must be active at the same time for the same duration. 0000 = immediate. 0001 = 1.0 sec. 0010 = 1.5 sec. 0011 = 2.0 sec. 0100 = 2.5 sec. 0101 = 3.0 sec. 0110 = 3.5 sec. 0111 = 4.0 sec. 1000 = 5.0 sec. 1001 = 6.0 sec. 1010 = 7.0 sec. 1011 = 8.0 sec. 1100 = 9.0 sec. 1101 = 10.0 sec. 1110 = 11.0 sec. 1111 = 12.0 sec.
[1:0]	RESET_PULSE_WIDTH[1:0]	Read/write	Defines the pulse width of the RESET_OUT signal. 00 = 500 $\mu\text{s}$ . 01 = 1 ms. 10 = 2 ms. 11 = 10 ms.

**PULSE\_GEN\_1\_DELAY, Register 0x2F**

Table 56. PULSE\_GEN\_1\_DELAY Bit Descriptions

Bits	Bit Name	Access	Description																													
[7:0]	PULSE_GEN_1_DELAY[7:0]	Read/write	Defines initial delay from the first clock of the first enable of Pulse Generator 1. Delay is defined as the number of clock cycles of the chosen period clock speed (see Register 0x35). For example,																													
			<table border="1"> <thead> <tr> <th rowspan="2">PULSE_GEN_1_DELAY</th> <th colspan="2">PULSE_GEN_1_PRD_CLK</th> </tr> <tr> <th>0</th> <th>1</th> </tr> </thead> <tbody> <tr> <td>0000 0000</td> <td>0</td> <td>0 ms</td> </tr> <tr> <td>0000 0001</td> <td>1</td> <td>125 ms</td> </tr> <tr> <td>0000 0010</td> <td>2</td> <td>250 ms</td> </tr> <tr> <td>0000 0011</td> <td>3</td> <td>375 ms</td> </tr> <tr> <td>0000 0100</td> <td>4</td> <td>500 ms</td> </tr> <tr> <td>...</td> <td>...</td> <td>...</td> </tr> <tr> <td>1111 1110</td> <td>254 ms</td> <td>31.750 sec</td> </tr> <tr> <td>1111 1111</td> <td>255 ms</td> <td>31.875 sec</td> </tr> </tbody> </table>	PULSE_GEN_1_DELAY	PULSE_GEN_1_PRD_CLK		0	1	0000 0000	0	0 ms	0000 0001	1	125 ms	0000 0010	2	250 ms	0000 0011	3	375 ms	0000 0100	4	500 ms	...	...	...	1111 1110	254 ms	31.750 sec	1111 1111	255 ms	31.875 sec
PULSE_GEN_1_DELAY	PULSE_GEN_1_PRD_CLK																															
	0	1																														
0000 0000	0	0 ms																														
0000 0001	1	125 ms																														
0000 0010	2	250 ms																														
0000 0011	3	375 ms																														
0000 0100	4	500 ms																														
...	...	...																														
1111 1110	254 ms	31.750 sec																														
1111 1111	255 ms	31.875 sec																														

**PULSE\_GEN\_1\_PERIOD, Register 0x30**

Table 57. PULSE\_GEN\_1\_PERIOD Bit Descriptions

Bits	Bit Name	Access	Description																													
[7:0]	PULSE_GEN_1_PERIOD[7:0]	Read/write	Defines period of Pulse Generator 1. Period is defined as the number of clock cycles of the chosen period clock speed (see Register 0x35). For example,																													
			<table border="1"> <thead> <tr> <th rowspan="2">PULSE_GEN_1_PERIOD</th> <th colspan="2">PULSE_GEN_1_PRD_CLK</th> </tr> <tr> <th>0</th> <th>1</th> </tr> </thead> <tbody> <tr> <td>0000 0000</td> <td>0 ms</td> <td>0 ms</td> </tr> <tr> <td>0000 0001</td> <td>1 ms</td> <td>125 ms</td> </tr> <tr> <td>0000 0010</td> <td>2 ms</td> <td>250 ms</td> </tr> <tr> <td>0000 0011</td> <td>3 ms</td> <td>375 ms</td> </tr> <tr> <td>0000 0100</td> <td>4 ms</td> <td>500 ms</td> </tr> <tr> <td>...</td> <td>...</td> <td>...</td> </tr> <tr> <td>1111 1110</td> <td>254 ms</td> <td>31.750 sec</td> </tr> <tr> <td>1111 1111</td> <td>255 ms</td> <td>31.875 sec</td> </tr> </tbody> </table>	PULSE_GEN_1_PERIOD	PULSE_GEN_1_PRD_CLK		0	1	0000 0000	0 ms	0 ms	0000 0001	1 ms	125 ms	0000 0010	2 ms	250 ms	0000 0011	3 ms	375 ms	0000 0100	4 ms	500 ms	...	...	...	1111 1110	254 ms	31.750 sec	1111 1111	255 ms	31.875 sec
PULSE_GEN_1_PERIOD	PULSE_GEN_1_PRD_CLK																															
	0	1																														
0000 0000	0 ms	0 ms																														
0000 0001	1 ms	125 ms																														
0000 0010	2 ms	250 ms																														
0000 0011	3 ms	375 ms																														
0000 0100	4 ms	500 ms																														
...	...	...																														
1111 1110	254 ms	31.750 sec																														
1111 1111	255 ms	31.875 sec																														

**PULSE\_GEN\_1\_ON\_TIME, Register 0x31**

Table 58. PULSE\_GEN\_1\_ON\_TIME Bit Descriptions

Bits	Bit Name	Access	Description																													
[7:0]	PULSE_GEN_1_ON_TIME[7:0]	Read/write	Defines on time of Pulse Generator 1. On time is defined as the number of clock cycles of the chosen clock speed (see Register 0x35). For example,																													
			<table border="1"> <thead> <tr> <th rowspan="2">PULSE_GEN_1_ON_TIME</th> <th colspan="2">PULSE_GEN_1_ON_CLK</th> </tr> <tr> <th>0</th> <th>1</th> </tr> </thead> <tbody> <tr> <td>0000 0000</td> <td>0 ms</td> <td>0 ms</td> </tr> <tr> <td>0000 0001</td> <td>1 ms</td> <td>125 ms</td> </tr> <tr> <td>0000 0010</td> <td>2 ms</td> <td>250 ms</td> </tr> <tr> <td>0000 0011</td> <td>3 ms</td> <td>375 ms</td> </tr> <tr> <td>0000 0100</td> <td>4 ms</td> <td>500 ms</td> </tr> <tr> <td>...</td> <td>...</td> <td>...</td> </tr> <tr> <td>1111 1110</td> <td>254 ms</td> <td>31.750 sec</td> </tr> <tr> <td>1111 1111</td> <td>255 ms</td> <td>31.875 sec</td> </tr> </tbody> </table>	PULSE_GEN_1_ON_TIME	PULSE_GEN_1_ON_CLK		0	1	0000 0000	0 ms	0 ms	0000 0001	1 ms	125 ms	0000 0010	2 ms	250 ms	0000 0011	3 ms	375 ms	0000 0100	4 ms	500 ms	...	...	...	1111 1110	254 ms	31.750 sec	1111 1111	255 ms	31.875 sec
PULSE_GEN_1_ON_TIME	PULSE_GEN_1_ON_CLK																															
	0	1																														
0000 0000	0 ms	0 ms																														
0000 0001	1 ms	125 ms																														
0000 0010	2 ms	250 ms																														
0000 0011	3 ms	375 ms																														
0000 0100	4 ms	500 ms																														
...	...	...																														
1111 1110	254 ms	31.750 sec																														
1111 1111	255 ms	31.875 sec																														

**PULSE\_GEN\_2\_DELAY, Register 0x32**

Table 59. PULSE\_GEN\_2\_DELAY Bit Descriptions

Bits	Bit Name	Access	Description																													
[7:0]	PULSE_GEN_2_DELAY[7:0]	Read/write	Defines initial delay from the first clock of the first enable of Pulse Generator 2. Delay is defined as the number of clock cycles of the chosen period clock speed (see Register 0x35). For example,																													
			<table border="1"> <thead> <tr> <th rowspan="2">PULSE_GEN_2_DELAY</th> <th colspan="2">PULSE_GEN_2_PRD_CLK</th> </tr> <tr> <th>0</th> <th>1</th> </tr> </thead> <tbody> <tr> <td>0000 0000</td> <td>0 ms</td> <td>0 ms</td> </tr> <tr> <td>0000 0001</td> <td>1 ms</td> <td>125 ms</td> </tr> <tr> <td>0000 0010</td> <td>2 ms</td> <td>250 ms</td> </tr> <tr> <td>0000 0011</td> <td>3 ms</td> <td>375 ms</td> </tr> <tr> <td>0000 0100</td> <td>4 ms</td> <td>500 ms</td> </tr> <tr> <td>...</td> <td>...</td> <td>...</td> </tr> <tr> <td>1111 1110</td> <td>254 ms</td> <td>31.750 sec</td> </tr> <tr> <td>1111 1111</td> <td>255 ms</td> <td>31.875 sec</td> </tr> </tbody> </table>	PULSE_GEN_2_DELAY	PULSE_GEN_2_PRD_CLK		0	1	0000 0000	0 ms	0 ms	0000 0001	1 ms	125 ms	0000 0010	2 ms	250 ms	0000 0011	3 ms	375 ms	0000 0100	4 ms	500 ms	...	...	...	1111 1110	254 ms	31.750 sec	1111 1111	255 ms	31.875 sec
PULSE_GEN_2_DELAY	PULSE_GEN_2_PRD_CLK																															
	0	1																														
0000 0000	0 ms	0 ms																														
0000 0001	1 ms	125 ms																														
0000 0010	2 ms	250 ms																														
0000 0011	3 ms	375 ms																														
0000 0100	4 ms	500 ms																														
...	...	...																														
1111 1110	254 ms	31.750 sec																														
1111 1111	255 ms	31.875 sec																														

**PULSE\_GEN\_2\_PERIOD, Register 0x33**

Table 60. PULSE\_GEN\_2\_PERIOD Bit Descriptions

Bits	Bit Name	Access	Description																													
[7:0]	PULSE_GEN_2_PERIOD[7:0]	Read/write	Defines period of Pulse Generator 2. Period is defined as the number of clock cycles of the chosen period clock speed (see Register 0x35). For example,																													
			<table border="1"> <thead> <tr> <th rowspan="2">PULSE_GEN_2_PERIOD</th> <th colspan="2">PULSE_GEN_2_PRD_CLK</th> </tr> <tr> <th>0</th> <th>1</th> </tr> </thead> <tbody> <tr> <td>0000 0000</td> <td>0 ms</td> <td>0 ms</td> </tr> <tr> <td>0000 0001</td> <td>1 ms</td> <td>125 ms</td> </tr> <tr> <td>0000 0010</td> <td>2 ms</td> <td>250 ms</td> </tr> <tr> <td>0000 0011</td> <td>3 ms</td> <td>375 ms</td> </tr> <tr> <td>0000 0100</td> <td>4 ms</td> <td>500 ms</td> </tr> <tr> <td>...</td> <td>...</td> <td>...</td> </tr> <tr> <td>1111 1110</td> <td>254 ms</td> <td>31.750 sec</td> </tr> <tr> <td>1111 1111</td> <td>255 ms</td> <td>31.875 sec</td> </tr> </tbody> </table>	PULSE_GEN_2_PERIOD	PULSE_GEN_2_PRD_CLK		0	1	0000 0000	0 ms	0 ms	0000 0001	1 ms	125 ms	0000 0010	2 ms	250 ms	0000 0011	3 ms	375 ms	0000 0100	4 ms	500 ms	...	...	...	1111 1110	254 ms	31.750 sec	1111 1111	255 ms	31.875 sec
PULSE_GEN_2_PERIOD	PULSE_GEN_2_PRD_CLK																															
	0	1																														
0000 0000	0 ms	0 ms																														
0000 0001	1 ms	125 ms																														
0000 0010	2 ms	250 ms																														
0000 0011	3 ms	375 ms																														
0000 0100	4 ms	500 ms																														
...	...	...																														
1111 1110	254 ms	31.750 sec																														
1111 1111	255 ms	31.875 sec																														

**PULSE\_GEN\_2\_ON\_TIME, Register 0x34**

Table 61. PULSE\_GEN\_2\_ON\_TIME Bit Descriptions

Bits	Bit Name	Access	Description																													
[7:0]	PULSE_GEN_2_ON_TIME[7:0]	Read/write	Defines on time of Pulse Generator 2. On time is defined as the number of clock cycles of the chosen clock speed (see Register 0x35). For example,																													
			<table border="1"> <thead> <tr> <th rowspan="2">PULSE_GEN_2_ON_TIME</th> <th colspan="2">PULSE_GEN_2_ON_CLK</th> </tr> <tr> <th>0</th> <th>1</th> </tr> </thead> <tbody> <tr> <td>0000 0000</td> <td>0 ms</td> <td>0 ms</td> </tr> <tr> <td>0000 0001</td> <td>1 ms</td> <td>125 ms</td> </tr> <tr> <td>0000 0010</td> <td>2 ms</td> <td>250 ms</td> </tr> <tr> <td>0000 0011</td> <td>3 ms</td> <td>375 ms</td> </tr> <tr> <td>0000 0100</td> <td>4 ms</td> <td>500 ms</td> </tr> <tr> <td>...</td> <td>...</td> <td>...</td> </tr> <tr> <td>1111 1110</td> <td>254 ms</td> <td>31.750 sec</td> </tr> <tr> <td>1111 1111</td> <td>255 ms</td> <td>31.875 sec</td> </tr> </tbody> </table>	PULSE_GEN_2_ON_TIME	PULSE_GEN_2_ON_CLK		0	1	0000 0000	0 ms	0 ms	0000 0001	1 ms	125 ms	0000 0010	2 ms	250 ms	0000 0011	3 ms	375 ms	0000 0100	4 ms	500 ms	...	...	...	1111 1110	254 ms	31.750 sec	1111 1111	255 ms	31.875 sec
PULSE_GEN_2_ON_TIME	PULSE_GEN_2_ON_CLK																															
	0	1																														
0000 0000	0 ms	0 ms																														
0000 0001	1 ms	125 ms																														
0000 0010	2 ms	250 ms																														
0000 0011	3 ms	375 ms																														
0000 0100	4 ms	500 ms																														
...	...	...																														
1111 1110	254 ms	31.750 sec																														
1111 1111	255 ms	31.875 sec																														

**PULSE\_GEN\_CONFIG, Register 0x35**

Table 62. PULSE\_GEN\_CONFIG Bit Descriptions

Bits	Bit Name	Access	Description
7	PULSE_GEN_1_INV	Read/write	0 = no inversion on Pulse Generator 1. On time is defined as the length of time a high signal is output. 1 = inverted output on Pulse Generator 1. On time is defined as the length of time a high signal is output.
6	PULSE_GEN_1_ON_CLK	Read/write	Defines clock speed for the on time of Pulse Generator 1. 0 = 1 ms. 1 = 125 ms. Setting PULSE_GEN_1_ON_CLK = 1 and PULSE_GEN_1_PRD_CLK = 0 is not a supported configuration.
5	PULSE_GEN_1_PRD_CLK	Read/write	Defines clock speed for the period of Pulse Generator 1. 0 = 1 ms. 1 = 125 ms. Setting PULSE_GEN_1_ON_CLK = 1 and PULSE_GEN_1_PRD_CLK = 0 is not a supported configuration.
4	PULSE_GEN_1_EN	Read/write	0 = Pulse Generator 1 is disabled. The off signal is output constantly. 1 = Pulse Generator 1 is enabled.
3	PULSE_GEN_2_INV	Read/write	0 = no inversion on Pulse Generator 2. On time is defined as the length of time a high signal is output. 1 = inverted output on Pulse Generator 2. On time is defined as the length of time a low signal is output.
2	PULSE_GEN_2_ON_CLK	Read/write	Defines clock speed for the on time of Pulse Generator 2. 0 = 1 ms. 1 = 125 ms. Setting PULSE_GEN_2_ON_CLK = 1 and PULSE_GEN_2_PRD_CLK = 0 is not a supported configuration.
1	PULSE_GEN_2_PRD_CLK	Read/write	Defines clock speed for the period of Pulse Generator 2. 0 = 1 ms. 1 = 125 ms. Setting PULSE_GEN_2_ON_CLK = 1 and PULSE_GEN_2_PRD_CLK = 0 is not a supported configuration.
0	PULSE_GEN_2_EN	Read/write	0 = Pulse Generator 2 is disabled. The off signal is output constantly. 1 = Pulse Generator 2 is enabled.

**LOGIC\_CFG, Register 0x36**

Table 63. LOGIC\_CFG Bit Descriptions

Bits	Bit Name	Access	Description
7	Reserved	Reserved	Reserved.
6	LY_INV	Read/write	0 = the LY output is not inverted before passing into the logic block. 1 = inverts the LY output from the logic block.
5	LC_INV	Read/write	0 = the LC input is not inverted before passing into the logic block. 1 = inverts LC input before passing it into the logic block.
4	LB_INV	Read/write	0 = the LB input is not inverted before passing into the logic block. 1 = inverts LB input before passing it into the logic block.
3	LA_INV	Read/write	0 = the LA input is not inverted before passing into the logic block. 1 = inverts LA input before passing it into the logic block.
[2:0]	LOGIC_SEL[2:0]	Read/write	Configures the digital mux for the logic block. Refer to Figure 19. 000 = off/disable. 001 = AND. 010 = OR. 011 = XOR. 100 = FF. 101 = IN_LA. 110 = IN_LB. 111 = IN_LC.

**LOGIC\_FF\_CFG, Register 0x37**

Table 64. LOGIC\_FF\_CFG Bit Descriptions

Bits	Bit Name	Access	Description
[7:2]	Reserved	Reserved	Reserved.
1	FF_SET	Read/write	0 = FF not set in the logic block. Refer to Figure 19. 1 = sets FF in the logic block.
0	FF_CLR	Read/write	0 = FF not cleared in the logic block. Refer to Figure 19. 1 = clears FF in the logic block.

**LOGIC\_INT\_EVENT\_EN, Register 0x38**

Table 65. LOGIC\_INT\_EVENT\_EN Bit Descriptions

Bits	Bit Name	Access	Description
[7:3]	Reserved	Reserved	Reserved.
2	LY_DBNC_DIS	Read/write	0 = output of the logic block is debounced before entering the event/interrupt block. 1 = output of the logic block is not debounced before entering the event/interrupt block. Use with caution because glitches may generate interrupts prematurely.
1	LOGIC_EVENT_EN	Read/write	0 = LY cannot generate interrupt. 1 = allows LY activity to generate events on the FIFO.
0	LOGIC_INT_LEVEL	Read/write	Configures the logic level of LY that generates an interrupt. 0 = LY is active low. 1 = LY is active high.

**POLL\_TIME\_CFG, Register 0x39**

Table 66. POLL\_TIME\_CFG Bit Descriptions

Bits	Bit Name	Access	Description
[7:4]	Reserved	Reserved	Reserved.
3	PRECHARGE_TIME	Read/write	Defines time to allow precharge. 0 = 100 $\mu$ s. 1 = 200 $\mu$ s.
2	Reserved	Reserved	Reserved.
[1:0]	KEY_POLL_TIME[1:0]	Read/write	Configures time between consecutive scan cycles. 00 = 10 ms. 01 = 20 ms. 10 = 30 ms. 11 = 40 ms.

**PIN\_CONFIG\_A, Register 0x3A**

Table 67. PIN\_CONFIG\_A Bit Descriptions

Bits	Bit Name	Access	Description
[7:6]	Reserved	Reserved	Reserved.
5	R5_CONFIG	Read/write	0 = GPIO 6. 1 = Row 5.
4	R4_CONFIG	Read/write	0 = GPIO 5 (see R4_EXTEND_CFG in Table 69 for alternate configuration, RESET). 1 = Row 4
3	R3_CONFIG	Read/write	0 = GPIO 4 (see R3_EXTEND_CFG in Table 69 for alternate configuration, LC). 1 = Row 3
2	R2_CONFIG	Read/write	0 = GPIO 3 1 = Row 2
1	R1_CONFIG	Read/write	0 = GPIO 2 1 = Row 1
0	R0_CONFIG	Read/write	0 = GPIO 1/LY (see R0_EXTEND_CFG in Table 69 for alternate configuration, LY). 1 = Row 0

**PIN\_CONFIG\_B, Register 0x3B**

Table 68. PIN\_CONFIG\_B Bit Descriptions

Bits	Bit Name	Access	Description
[7:5]	Reserved	Reserved	Reserved.
4	C4_CONFIG	Read/write	0 = GPIO 11. 1 = Column 4.
3	C3_CONFIG	Read/write	0 = GPIO 10. 1 = Column 3.
2	C2_CONFIG	Read/write	0 = GPIO 9. 1 = Column 2.
1	C1_CONFIG	Read/write	0 = GPIO 8 (see C1_EXTEND_CFG in Table 69 for alternate configuration, PULSE_GEN_2). 1 = Column 1.
0	C0_CONFIG	Read/write	0 = GPIO 7 (see C0_EXTEND_CFG in Table 69 for alternate configuration, PULSE_GEN_1). 1 = Column 0.

**PIN\_CONFIG\_C, Register 0x3C**

Table 69. PIN\_CONFIG\_C Bit Descriptions

Bits	Bit Name	Access	Description
7	PULL_SELECT	Read/write	0 = 300 k $\Omega$ resistor used for row pull-up during key scanning. 1 = 100 k $\Omega$ resistor used for row pull-up during key scanning.
6	C0_EXTEND_CFG	Read/write	0 = C0 remains configured as GPIO 7. 1 = C0 reconfigured as PULSE_GEN_1 output.
5	R4_EXTEND_CFG	Read/write	0 = R4 remains configured as GPIO 5. 1 = R4 reconfigured as RESET_OUT output.
4	C1_EXTEND_CFG	Read/write	0 = C1 remains configured as GPIO 8. 1 = C1 reconfigured as PULSE_GEN_2 output.
3	R3_EXTEND_CFG	Read/write	0 = R3 remains configured as GPIO 4. 1 = R3 reconfigured as LC input for the logic block.
[2:1]	Reserved	Reserved	Reserved.
0	R0_EXTEND_CFG	Read/write	0 = R0 remains configured as GPIO 1. 1 = R0 reconfigured as LY output from the logic block.

**GENERAL\_CFG, Register 0x3D**

Table 70. GENERAL\_CFG Bit Descriptions

Bits	Bit Name	Access	Description
7	OSC_EN	Read/write	0 = disables internal 800 kHz oscillator. 1 = enables internal 800 kHz oscillator.
[6:5]	OSC_FREQ[1:0]	Read/write	Sets the input clock frequency fed from the base 800 kHz oscillator to the digital core. Slower frequencies result in less quiescent current, but key and GPI scan times increase. 00 = 50 kHz. 01 = 100 kHz. 10 = 200 kHz. 11 = 400 kHz.
[4:3]	Reserved	Reserved	Reserved.
2	SW_RESET	Read/write	Software reset. Set to 1 to reset the ADP5586. This function is similar to bringing RST low, then high. Wait at least 200 $\mu$ s before reprogramming the device.
1	INT_CFG	Read/write	Configures the behavior of the INT pin if the user tries to clear it while an interrupt is pending. 0 = INT pin remains asserted if an interrupt is pending. 1 = INT pin deasserts for 50 $\mu$ s and reasserts if an interrupt is pending.
0	RST_CFG	Read/write	Configures the response of the ADP5586 to the RST pin and the SW_RESET bit. 0 = the ADP5586 resets if RST is low. 1 = the ADP5586 does not reset if RST is low.

**INT\_EN, Register 0x3E**

Table 71. INT\_EN Bit Descriptions

Bits	Bit Name	Access	Description
[7:5]	Reserved	Reserved	Reserved.
4	LOGIC_IEN	Read/write	0 = Logic 1 interrupt is disabled. 1 = asserts the $\overline{\text{INT}}$ pin if the LOGIC_INT bit is set (Register 0x01, Bit 4).
3	Reserved	Reserved	Reserved.
2	OVRFLOW_IEN	Read/write	0 = overflow interrupt is disabled. 1 = asserts the $\overline{\text{INT}}$ pin if the OVRFLOW_INT bit is set (Register 0x01, Bit 2).
1	GPI_IEN	Read/write	0 = GPI interrupt is disabled. 1 = asserts the $\overline{\text{INT}}$ pin if the GPI_INT is set (Register 0x01, Bit 1).
0	EVENT_IEN	Read/write	0 = event interrupt is disabled. 1 = asserts the $\overline{\text{INT}}$ pin if the EVENT_INT is set (Register 0x01, Bit 0).



APPLICATIONS SCHEMATIC

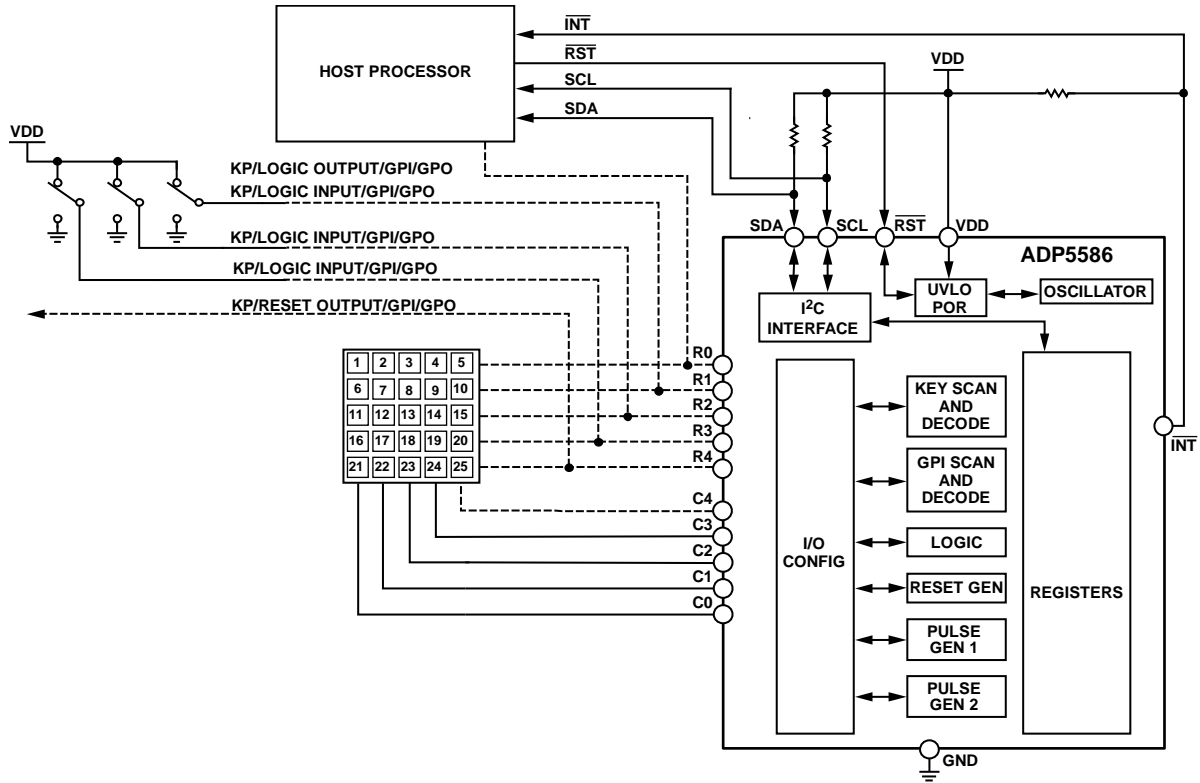

Figure 28. Typical Applications Schematic

11148-028

OUTLINE DIMENSIONS



01-20-2011-A

Figure 29. 16-Ball Wafer Level Chip Scale Package [WLCSP] (CB-16-10)  
Dimensions shown in millimeters

ORDERING GUIDE

Model <sup>1</sup>	Temperature Range	Package Description	Package Option
ADP5586ACBZ-00-R7	-40°C to +85°C	16-Ball Wafer Level Chip Scale Package [WLCSP]	CB-16-10
ADP5586ACBZ-01-R7	-40°C to +85°C	16-Ball Wafer Level Chip Scale Package [WLCSP]	CB-16-10
ADP5586ACBZ-03-R7	-40°C to +85°C	16-Ball Wafer Level Chip Scale Package [WLCSP]	CB-16-10
ADP5586CB-EVALZ		WLCSP Evaluation Board	CB-16-10

<sup>1</sup> Z = RoHS Compliant Part.

**NOTES**

**NOTES**

I<sup>2</sup>C refers to a communications protocol originally developed by Philips Semiconductors (now NXP Semiconductors).



## Стандарт Электрон Связь

Мы молодая и активно развивающаяся компания в области поставок электронных компонентов. Мы поставляем электронные компоненты отечественного и импортного производства напрямую от производителей и с крупнейших складов мира.

Благодаря сотрудничеству с мировыми поставщиками мы осуществляем комплексные и плановые поставки широчайшего спектра электронных компонентов.

Собственная эффективная логистика и склад в обеспечивает надежную поставку продукции в точно указанные сроки по всей России.

Мы осуществляем техническую поддержку нашим клиентам и предпродажную проверку качества продукции. На все поставляемые продукты мы предоставляем гарантию .

Осуществляем поставки продукции под контролем ВП МО РФ на предприятия военно-промышленного комплекса России , а также работаем в рамках 275 ФЗ с открытием отдельных счетов в уполномоченном банке. Система менеджмента качества компании соответствует требованиям ГОСТ ISO 9001.

Минимальные сроки поставки, гибкие цены, неограниченный ассортимент и индивидуальный подход к клиентам являются основой для выстраивания долгосрочного и эффективного сотрудничества с предприятиями радиоэлектронной промышленности, предприятиями ВПК и научно-исследовательскими институтами России.

С нами вы становитесь еще успешнее!

### Наши контакты:

**Телефон:** +7 812 627 14 35

**Электронная почта:** [sales@st-electron.ru](mailto:sales@st-electron.ru)

**Адрес:** 198099, Санкт-Петербург,  
Промышленная ул, дом № 19, литера Н,  
помещение 100-Н Офис 331