



31.2 x 17.8 mm

# AMW004 'Wallaby'

## Cloud-Connected Wi-Fi Module

Connecting your device to the cloud just got a whole lot easier

### IT'S ALL ABOUT THE CLOUD

Using a Wi-Fi module to connect your device to the internet only solves half the problem. ACKme Wi-Fi modules bridge the gap by providing ultra-low power cloud connectivity coupled with an easy-to-use serial communication command set.

### FEATURES

- Standalone WICED Wi-Fi Networking module including an apps processor and on-board antenna
- Multiple serial interfaces: UART, SPI, I2C
- Sensors.com cloud API for remote device monitoring and control
- Ultra-low power mode for battery operation
- On-board TCP/IP stack includes SSL/TLS/HTTPS security
- Secure over-the-air (OTA) upgrade using industry standard security protocols
- Various Wi-Fi provisioning options including WPS and softAP/webserver

### HIGHLIGHTS

The AMW004 'Wallaby' module is a fully certified small form factor, low power WICED-based Wi-Fi networking module perfectly suited to deeply embedded applications for medium to high volumes.

The module runs an embedded TCP/IP networking stack with SSL/TLS/HTTPS security and includes an onboard PCB trace antenna and u.FL connector for external antenna all in a physical footprint of just 31.2mm x 17.8mm (1.25" x 0.7").

ACKme WiConnect firmware is pre-installed on all AMW004 modules. WiConnect is an intuitive and reliable serial Wi-Fi networking application that includes free (optional) support for cloud connectivity powered by Sensors.com.

### APPLICATIONS

- Environmental & energy monitoring
- Wireless Sensing, remote data logging
- HVAC, power, light & thermostat control
- Appliance control
- Security cameras
- Door/window monitoring
- Entry control and monitoring
- Fitness equipment
- Home health monitoring
- Medical devices
- Audio
- Toys & robots
- And more...

### AMW004 SYSTEM ARCHITECTURE

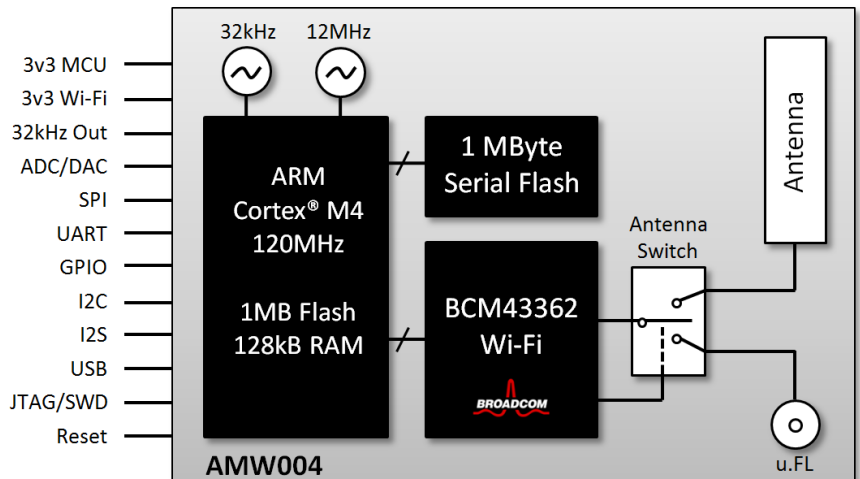

## AMW004 SPECIFICATIONS

Networking Standards	802.11b/g/n
Frequency Band	2.4GHz – Channels 1-14
Wi-Fi Security	Open, WEP, WPA, WPA2
Network Protocols	UDP, TCP, ARP, ICMP, DNS, SNTP, HTTP, DHCP, SMTP, Sensors.com
Network Security	SSL3.0/TLS1.2, HTTPS, Secure OTA Upgrade
Communications Interfaces	UART, SPI, I2C, USB, JTAG
Data Throughput	>10Mbit/s SPI, 4Mbit/s UART
Microprocessor & Memory	ARM CM4 @ 120MHz incl. 1MB flash and 128kB RAM, on-board 8Mbit (1MByte) SPI-serial flash
Peripherals	GPIO, ADC, DAC, PWM, I2S
Real Time Clock	Time-of-day, low power alarms/wakeup
Max. RF Transmit Power	+18.5dBm (11b), +15.5dBm (11g), +13.5dBm (11n)
Min. Receive Sensitivity	-94dBm (11b/g), -86dBm (11n)
Communications Range	>330m (1000ft) line of sight
Antenna	On-board PCB-style & u.FL connector for external antenna
Power Consumption @ 25°C	Standby: 1.8µA (incl. 32kHz RTC) Sleep: 28µA Wi-Fi Powersave: 0.77mA (DTIM=3) Active Receive: 6.9mA (1Mbit/s UDP) Active Transmit: 12.5mA (1Mbit/s UDP)
Supply Voltage	+3.3V ±10%
Operating Temperature	-30°C to +85°C
Size	31.8mm x 17.8mm x 3.1mm (1.25" x 0.7" x 0.08")
Certifications	FCC, CE, IC
Software	ACKme WiConnect serial Wi-Fi Application is pre-installed on all modules

## AMW004 EVALUATION BOARD

Evaluating the AMW004 module using ACKme’s WiConnect serial Wi-Fi software is easy. Simply plug the board into a PC using a standard USB cable, open a terminal and start typing!

The evaluation board includes:

- USB-serial interface for simplified UART communications & power
- Peripheral interface including two buttons, five LEDs for I/O control and status indication, and a thermistor for temperature measurement
- Expansion headers to break out every pin on the module
- Reset button

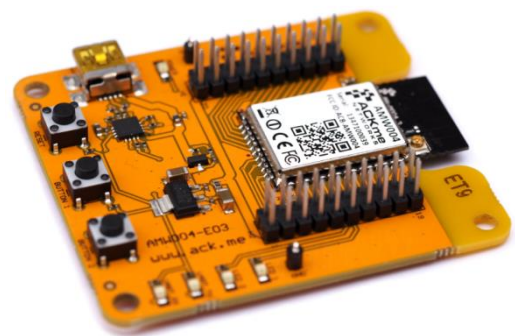

➔ Contact us: <http://ack.me/contact> or +1 (408) 402 5708  
Or for more information, visit us online at <http://ack.me>

AMW004 (Wallaby)	AMW004 surface mount module
AMW004-A01 (Hornet)	AMW004 with pluggable module adapter (2mm pin pitch)
AMW004-E03 (Mackerel)	AMW004 surface-mounted on WiConnect Evaluation Board
AMW004-E02 (Marlin+Hornet)	AMW004 pluggable module adapter with WiConnect Eval Board
AMW004-E01 (Snapper)	AMW004 surface-mounted on WICED SDK Evaluation Board



### ABOUT ACKme NETWORKS, INC.

ACKme Networks offers a range of industry leading cloud-connected wireless communication modules including Wi-Fi, Bluetooth, Bluetooth Low Energy and GPRS cellular. ACKme is headquartered in Silicon Valley, USA with a design centre in Sydney, Australia and a range of international distributors.



## Стандарт Электрон Связь

Мы молодая и активно развивающаяся компания в области поставок электронных компонентов. Мы поставляем электронные компоненты отечественного и импортного производства напрямую от производителей и с крупнейших складов мира.

Благодаря сотрудничеству с мировыми поставщиками мы осуществляем комплексные и плановые поставки широчайшего спектра электронных компонентов.

Собственная эффективная логистика и склад в обеспечивает надежную поставку продукции в точно указанные сроки по всей России.

Мы осуществляем техническую поддержку нашим клиентам и предпродажную проверку качества продукции. На все поставляемые продукты мы предоставляем гарантию .

Осуществляем поставки продукции под контролем ВП МО РФ на предприятия военно-промышленного комплекса России , а также работаем в рамках 275 ФЗ с открытием отдельных счетов в уполномоченном банке. Система менеджмента качества компании соответствует требованиям ГОСТ ISO 9001.

Минимальные сроки поставки, гибкие цены, неограниченный ассортимент и индивидуальный подход к клиентам являются основой для выстраивания долгосрочного и эффективного сотрудничества с предприятиями радиоэлектронной промышленности, предприятиями ВПК и научно-исследовательскими институтами России.

С нами вы становитесь еще успешнее!

### Наши контакты:

**Телефон:** +7 812 627 14 35

**Электронная почта:** [sales@st-electron.ru](mailto:sales@st-electron.ru)

**Адрес:** 198099, Санкт-Петербург,  
Промышленная ул, дом № 19, литера Н,  
помещение 100-Н Офис 331