

Evaluating the **AD5321** 12-Bit, Single-Channel Voltage Output Digital-to-Analog Converter (DAC)

FEATURES

- Full featured evaluation board (**EVAL-AD5321DBZ**) in conjunction with the nanoDAC motherboard (**EVAL-MBnanoDAC-SDZ**)
- On-board references
- Various link options
- PC control in conjunction with Analog Devices, Inc., system demonstration platform (SDP)

EVALUATION KIT CONTENTS

- EVAL-AD5321DBZ** evaluation board
- EVAL-MBnanoDAC-SDZ** motherboard
- USB cable

SOFTWARE REQUIRED

- EVAL-AD5321DBZ** evaluation software

HARDWARE REQUIRED

- EVAL-SDP-CB1Z** controller board (**SDP-B** controller board), must be purchased separately

GENERAL DESCRIPTION

This user guide details the operation of the **EVAL-AD5321DBZ** evaluation board for the **AD5321**.

The **EVAL-AD5321DBZ** evaluation board is designed to quickly prototype **AD5321** circuits and reduce design time. The **AD5321** operates from a single 2.7 V to 5.5 V supply.

The **EVAL-AD5321DBZ** evaluation board interfaces with the USB port of a PC via the **SDP-B** controller board. Software can be downloaded via the **EVAL-AD5321DBZ** product page that allows users to program the **AD5321**.

This evaluation board requires the **SDP-B** controller board, which is available for order on the Analog Devices, Inc., website.

Full data on the **AD5321** can be found in the **AD5321** data sheet available from Analog Devices and should be consulted in conjunction with this user guide when using the evaluation board.

PHOTOGRAPH OF THE **EVAL-AD5321DBZ**, **EVAL-MBnanoDAC-SDZ**, AND THE **EVAL-SDP-CB1Z**

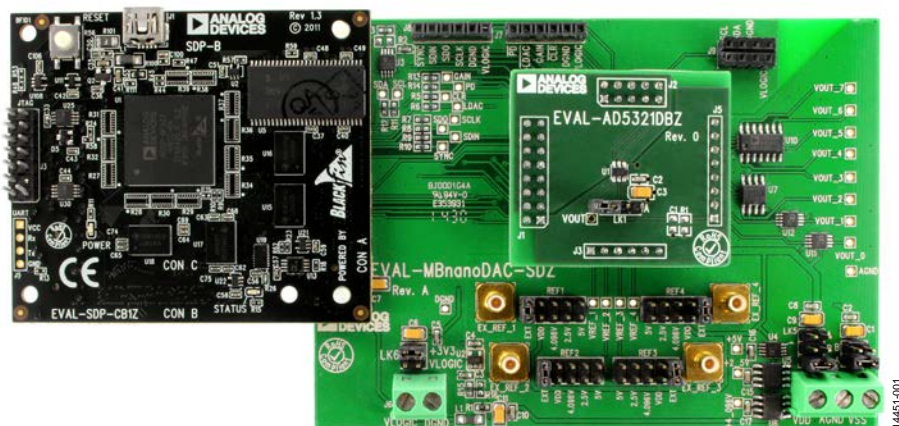

Figure 1.

TABLE OF CONTENTS

Features	1	Installing the AD5321 Evaluation Software	4
Evaluation Kit Contents.....	1	Running the Software.....	4
Software Required	1	Evaluation Software.....	5
Hardware Required	1	Write to DAC Register	5
General Description	1	Power-Down Control.....	5
EVAL-AD5321DBZ, EVAL-MBnanoDAC-SDZ, and the EVAL-SDP-CB1Z Boards	1	Evaluation Board Schematics and Artwork	6
Revision History	2	EVAL-MBnanoDAC-SDZ Motherboard.....	6
Evaluation Board Hardware.....	3	EVAL-AD5321DBZ Daughter Board	9
Power Supplies	3	Ordering Information	11
EVAL-AD5321DBZ Daughter board Link Options	3	Bill of Materials	11
Evaluation Software.....	4		

REVISION HISTORY

3/2017—Revision 0: Initial Version

EVALUATION BOARD HARDWARE

POWER SUPPLIES

The *nanoDAC*® EVAL-MBnanoDAC-SDZ motherboard supports single and dual power supplies.

The EVAL-AD5321DBZ evaluation board can be powered either from the SDP-B port or externally by the J5 and J6 connectors, as described in Table 1.

Both AGND and DGND inputs are provided on the EVAL-AD5321DBZ. The AGND and DGND planes connect at one location on the EVAL-MBnanoDAC-SDZ. It is recommended that AGND and DGND do not connect elsewhere in the system to avoid ground loop problems.

All supplies are decoupled to ground with a 10 μ F tantalum capacitor and 0.1 μ F ceramic capacitor.

Table 1. Power Supply Connectors

Connector	Label	Voltage
J5, Pin 1 (J5-1)	VDD	Analog positive power supply, V_{DD} ; 5.5 V single and dual supply
J5, Pin 2 (J5-2)	AGND	Analog ground
J5, Pin 3 (J5-3)	VSS	Analog negative power supply, V_{SS} ; -5.5 V dual supply
J6, Pin1 (J6-1)	VLOGIC	Digital supply from 1.8 V to V_{DD}
J6, Pin 2 (J6-2)	DGND	Digital Ground

Link Options

A number of link options are incorporated in the EVAL-MBnanoDAC-SDZ and must be set for the required operating conditions before using the EVAL-AD5321DBZ. Table 2 describes the positions of the links to control the evaluation board via the SDP-B controller board using a PC and external power supplies. The functions of these link options are described in detail in Table 4. The positions listed in Table 2 to Table 4 match the evaluation board imprints (see Figure 10).

Table 2. Link Options Setup for SDP-B Control (Default)

Link Number	Position
REF1	EXT
REF2	EXT
REF3	EXT
REF4	EXT
LK5	C
LK6	+3V3
LK7	B

EVAL-AD5321DBZ DAUGHTER BOARD LINK OPTIONS

The EVAL-AD5321DBZ daughter board has a link option. This link sets the LSB of the I²C address of the DAC. Table 3 describes the function of this link. For proper device operation, set the LK1 position to B.

Table 3. Link Options for Daughterboard

Link	Pin	Position
LK1	A0	A (high) B (low, default)

Table 4. Link Functions

Link Number	Position
REF1 to REF4	These links select the reference source. Position EXT selects an off board voltage reference via the appropriate EXT_REF connector. Position VDD selects V_{DD} as the reference source. Position 4.096V selects the on-board 4.096 V reference as the reference source. Position 2.5V selects the on-board 2.5 V reference as the reference source. Position 5V selects the on-board 5 V reference as the reference source.
LK5	This link selects the positive DAC analog voltage source. Position A selects the internal voltage source from the SDP-B controller board. Position B selects the internal voltage source +3.3 V from the ADP121 on the motherboard. Position C selects an external supply voltage, V_{DD} .
LK6	This link selects the VLOGIC voltage source. Position +3V3 selects the digital voltage source from the SDP-B board (+3V3). Position VLOGIC selects an external digital supply voltage, V_{LOGIC} .
LK7	This link selects the negative DAC analog voltage source. Position A selects V_{SS} . Position B selects AGND.

EVALUATION SOFTWARE

INSTALLING THE EVAL-AD5321DBZ EVALUATION SOFTWARE

The EVAL-AD5321DBZ Evaluation Software is compatible with Windows® Vista (64-bit/32-bit), and Windows 7 (64-bit/32-bit).

Install the software before connecting the SDP-B to the PC.

To install the EVAL-AD5321DBZ Evaluation Software, take the following steps:

1. Start the Windows operating system.
2. Download the installation software from the [EVAL-AD5321DBZ](#) evaluation board page.
3. Run the **setup.exe** file from the installer folder if it doesn't run automatically.
4. After installation is completed, power up the evaluation board as described in the Power Supplies section.
5. Connect the EVAL-AD5321DBZ to the SDP-B controller board and the SDP-B controller board to the PC using the USB cable included in the evaluation kit.
6. When the software detects the EVAL-AD5321DBZ, proceed through any dialog boxes that appear to finalize the installation.

RUNNING THE SOFTWARE

To run the program, proceed with the following:

1. Connect the EVAL-AD5321DBZ to the SDP-B controller board and connect the USB cable between the board and the PC.
2. Power up the EVAL-AD5321DBZ as described in the Power Supplies section.
3. Click **Start > All Programs > Analog Devices > AD5321 Evaluation Software** to locate the evaluation board.

If the SDP-B controller board is not connected to the USB port when the software launches, a connectivity error displays (see Figure 2).

Connect the SDP-B controller board to the USB port of the PC and wait a few seconds. Once the SDP-B controller board and the EVAL-AD5321DBZ are detected, the display updates (see Figure 3).

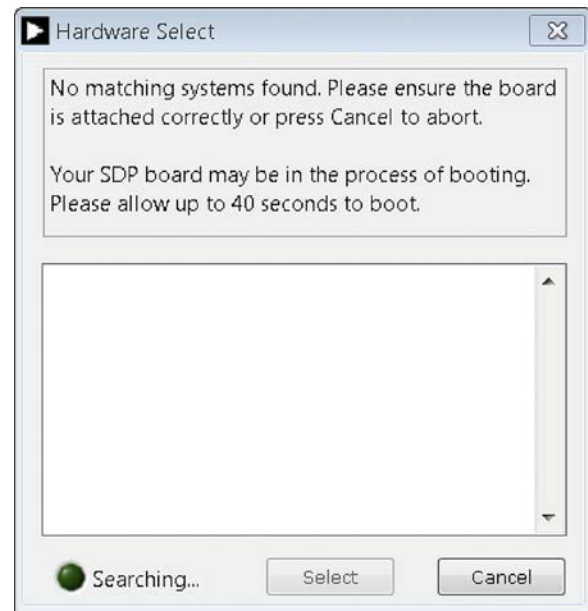

Figure 2. Connectivity Error

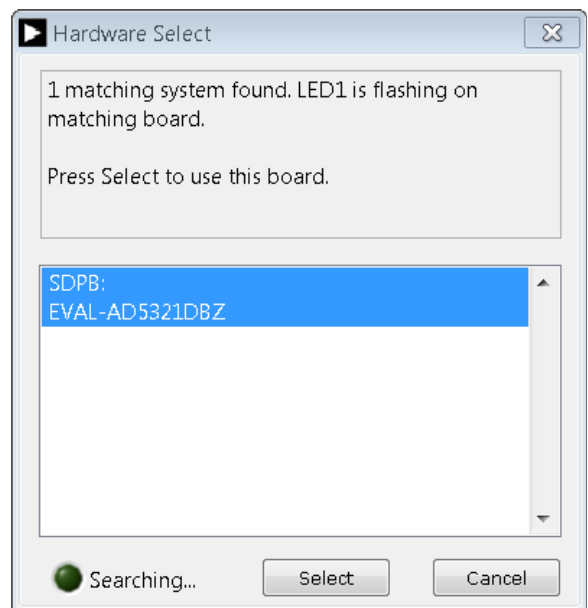

Figure 3. Hardware Select

Alternatively, the EVAL-AD5321DBZ Evaluation Software can be used without an evaluation board. The EVAL-AD5321DBZ Evaluation Software runs in simulation mode displaying expected outputs based on the input data. The main window of the EVAL-AD5321DBZ Evaluation Software then opens, shown in Figure 4.

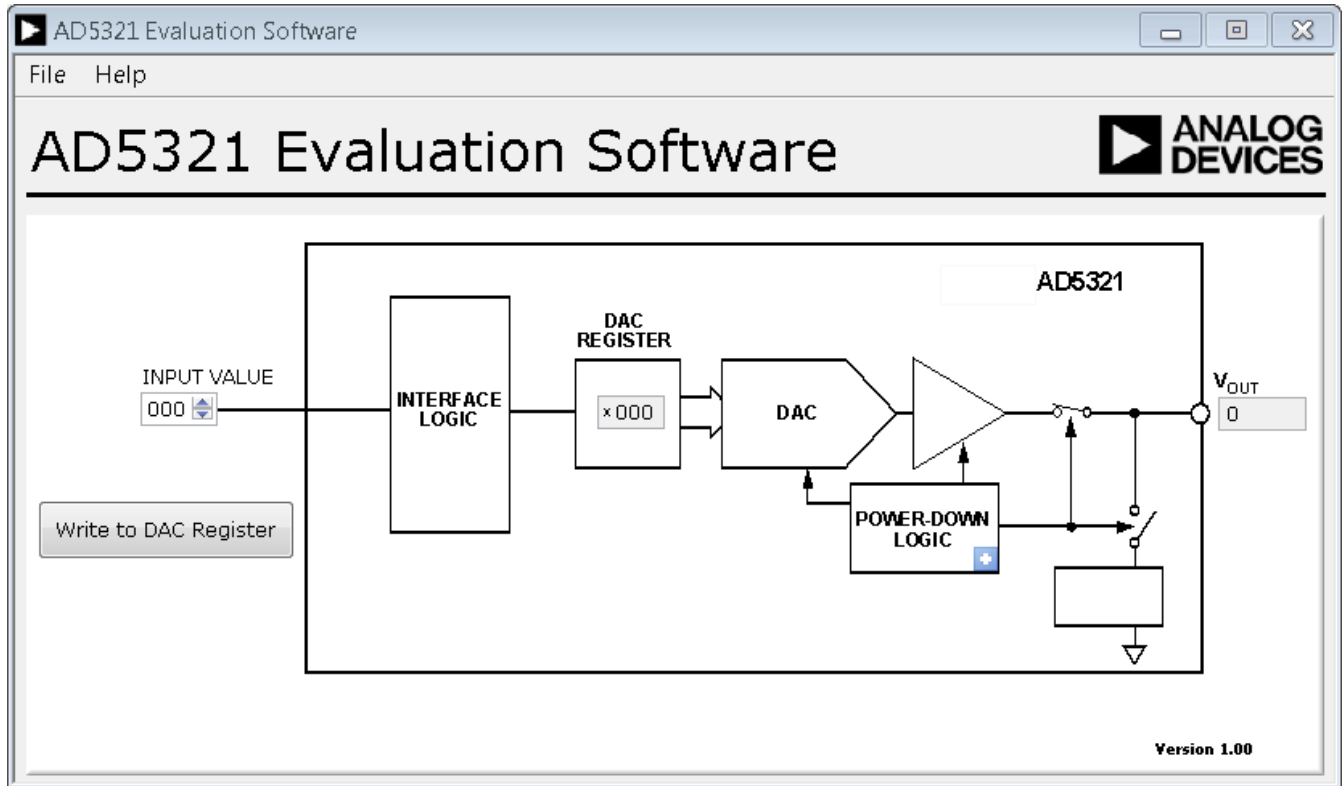

Figure 4. AD5321 Evaluation Board Software Main Window

EVALUATION SOFTWARE

The EVAL-AD5321DBZ evaluation software allows the user to program values to the DAC register.

WRITE TO DAC REGISTER

Select the **Write to DAC Register** button to load the code of the input data control to the DAC register of the DAC.

POWER-DOWN CONTROL

Click the blue progressive disclosure button on the **POWER-DOWN LOGIC** block to access the **Powerdown Config** window, as shown in Figure 5. This window allows the user to operate the AD5321 in normal mode or three different power-down modes. When the power-down setting for the DAC is selected, click **OK** to write the appropriate values to the AD5321.

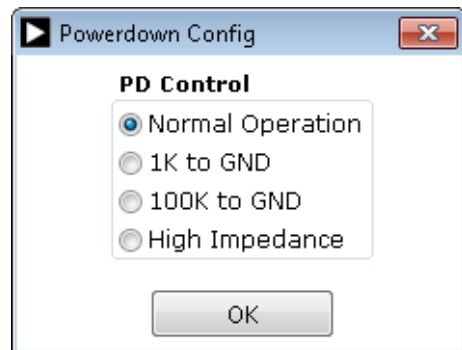

Figure 5. Powerdown Config Window

EVALUATION BOARD SCHEMATICS AND ARTWORK
 EVAL-MBnanoDAC-SDZ MOTHERBOARD

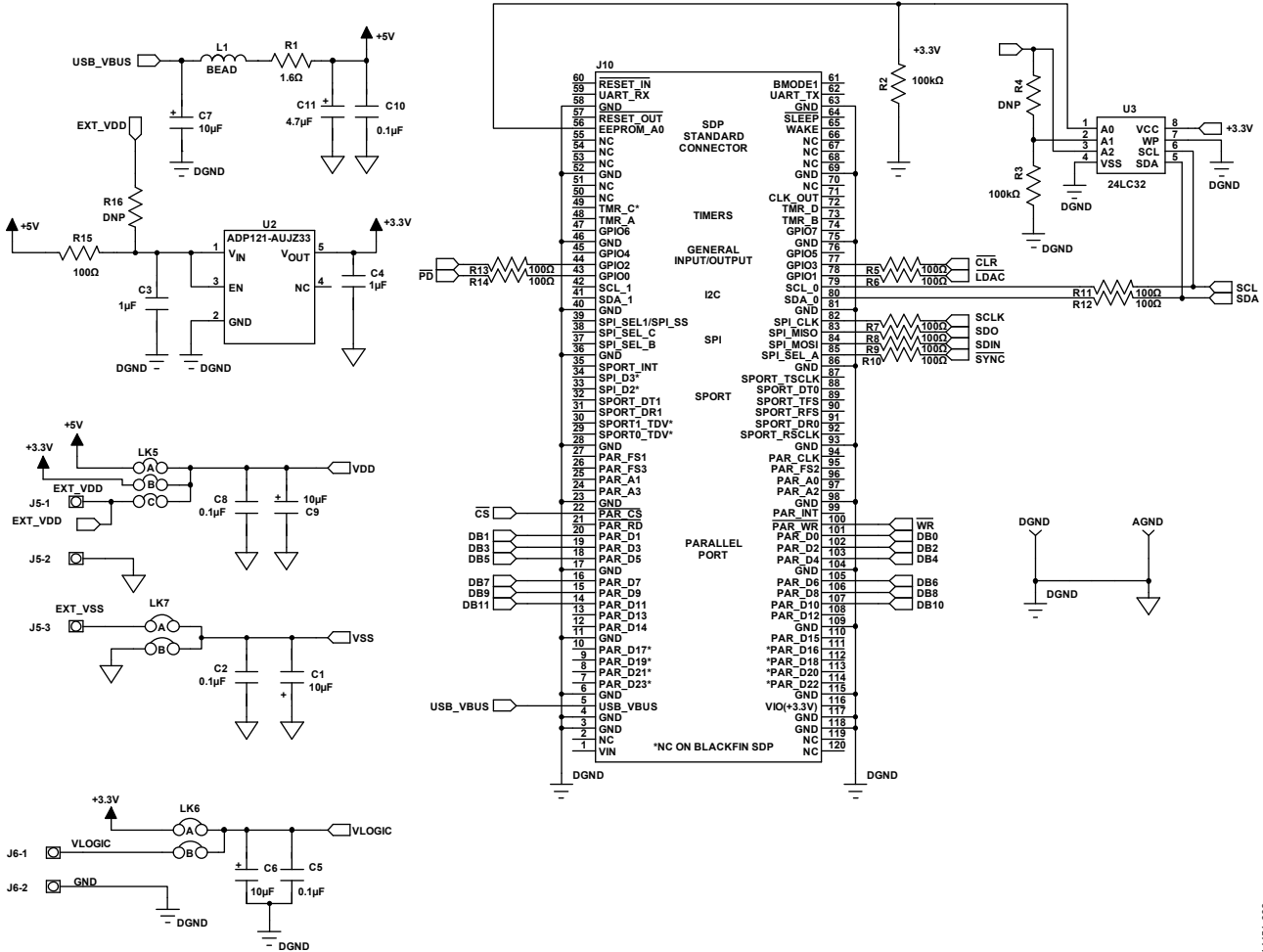

Figure 6. EVAL-MBnanoDAC-SDZ Motherboard, SDP-B Controller Board Connector, and Power Supply

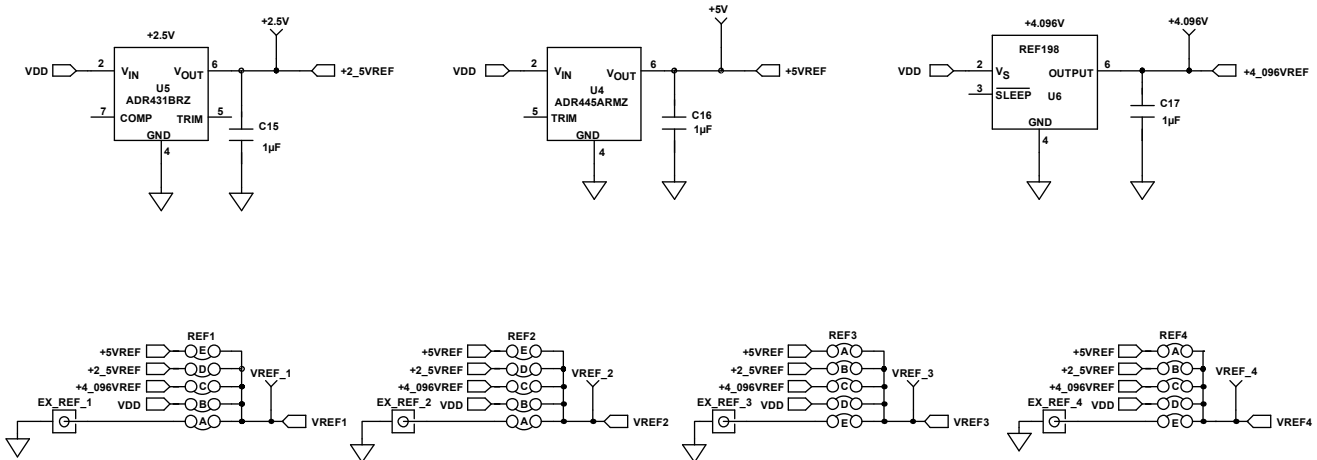

Figure 7. EVAL-MBnanoDAC-SDZ Motherboard Reference Voltage Selector Circuit

14451-006

14451-007

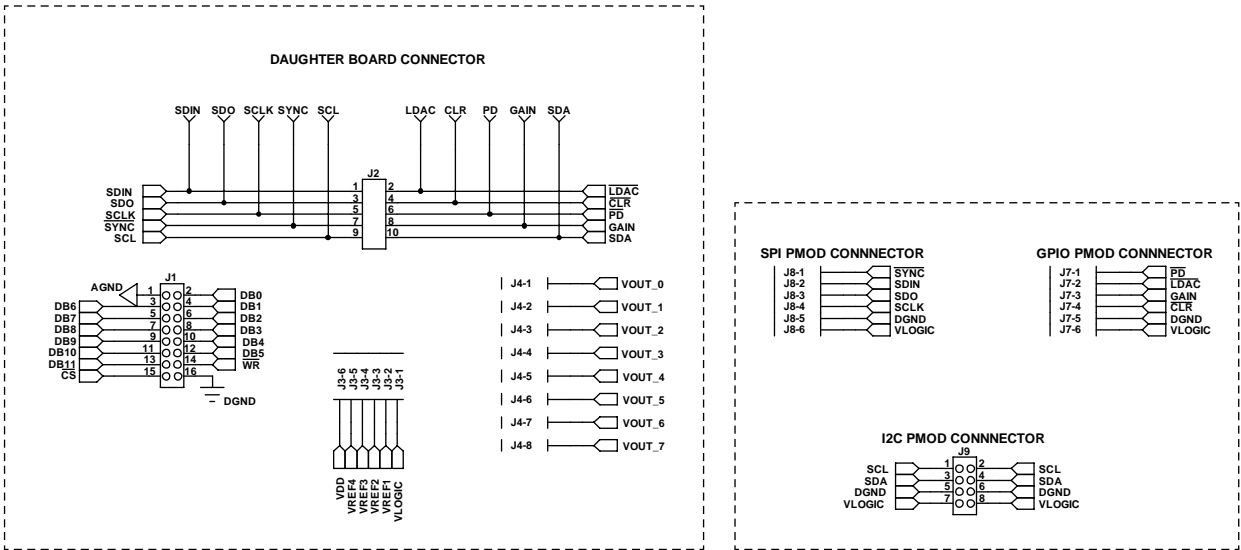

Figure 8. EVAL-MBnanoDAC-SDZ Motherboard Connectors to Daughter Board and Serial Interface

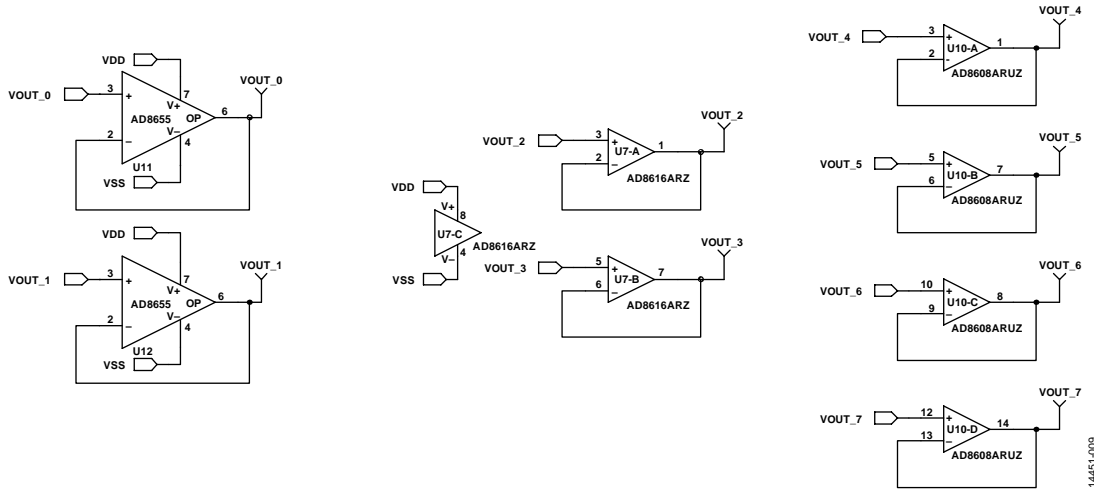

Figure 9. EVAL-MBnanoDAC-SDZ Motherboard Output Amplifier Circuit

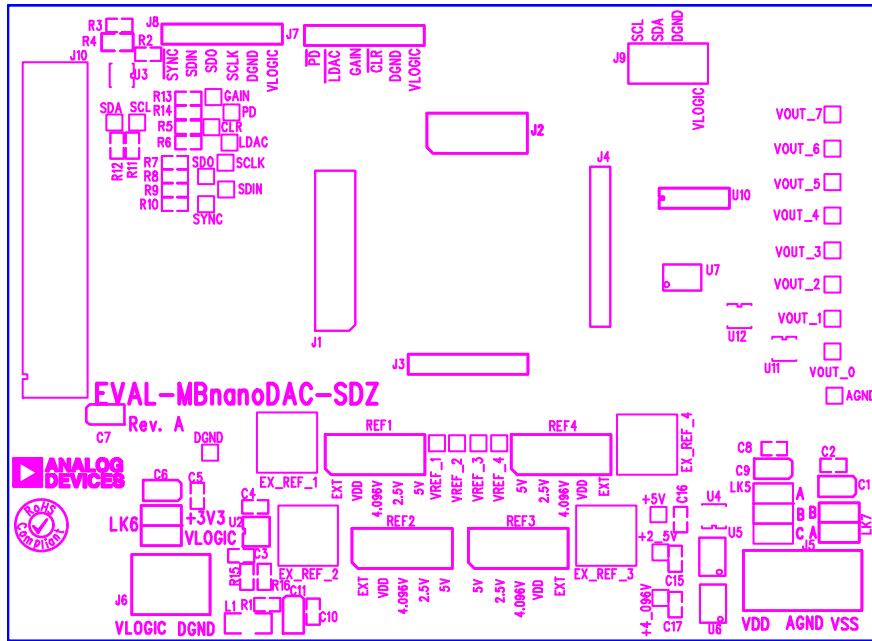

Figure 10. EVAL-MBnanoDAC-SDZ Motherboard Component Placement

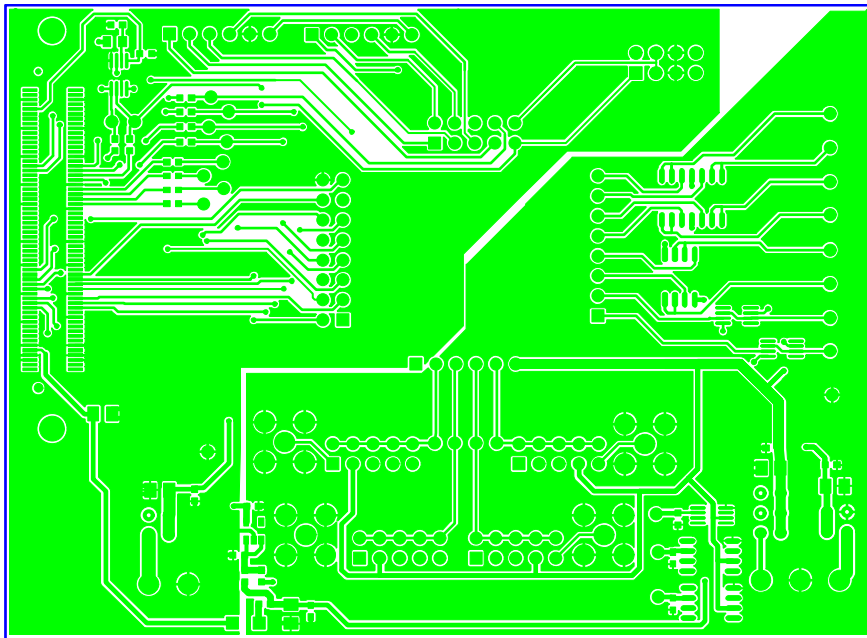

Figure 11. EVAL-MBnanoDAC-SDZ Motherboard Top Side Routing

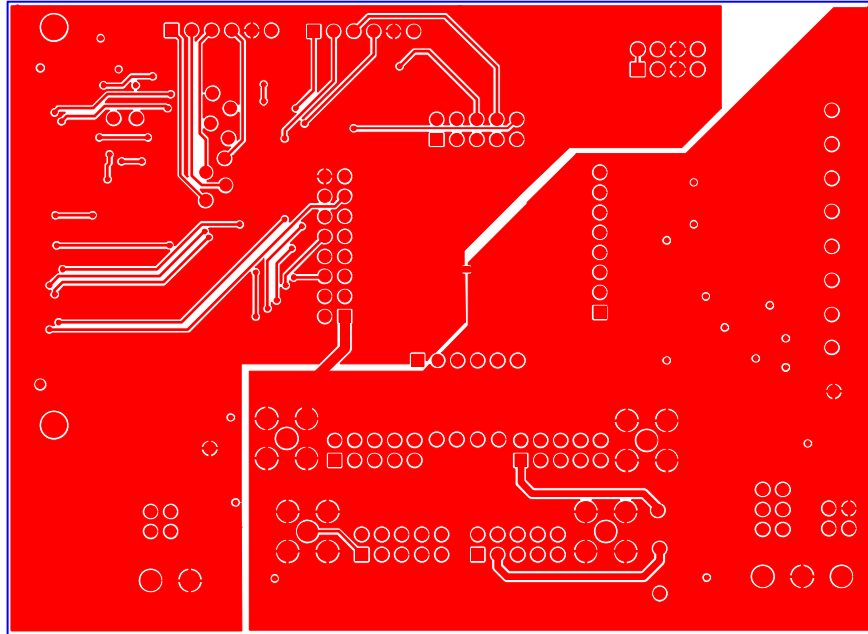

Figure 12. EVAL-MBnanoDAC-SDZ Motherboard Bottom Side Routing

EVAL-AD5321DBZ DAUGHTER BOARD

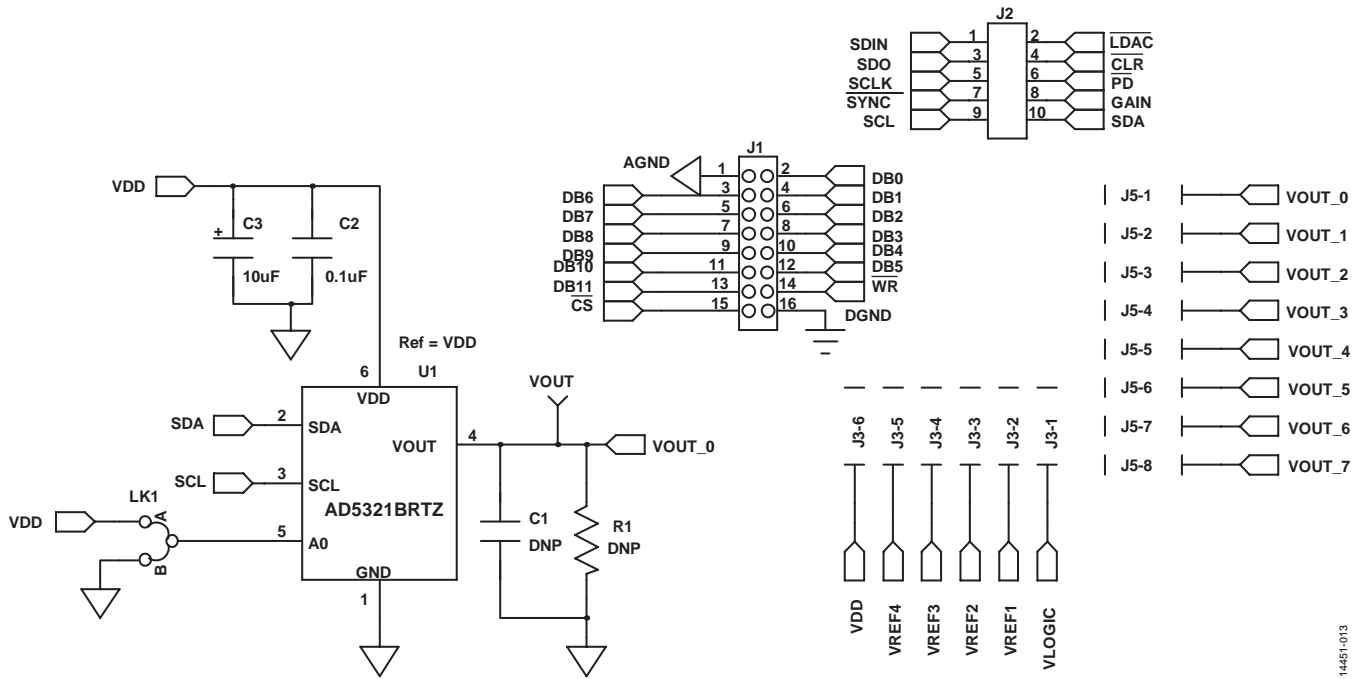

Figure 13. EVAL-AD5321DBZ Daughter Board Schematics

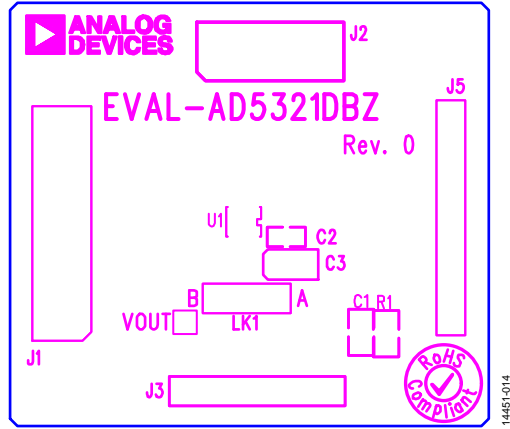

Figure 14. EVAL-AD5321DBZ Daughter Board Component Placement

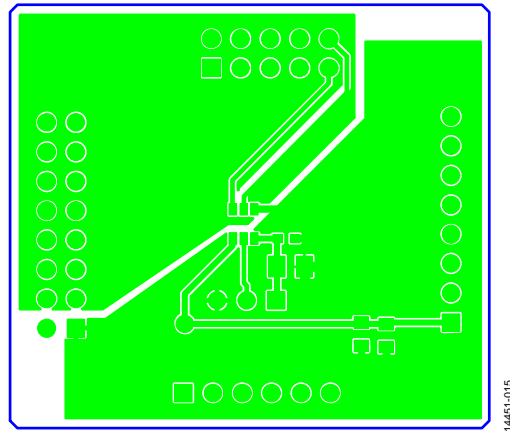

Figure 15. EVAL-AD5321DBZ Daughter Board Top Side Routing

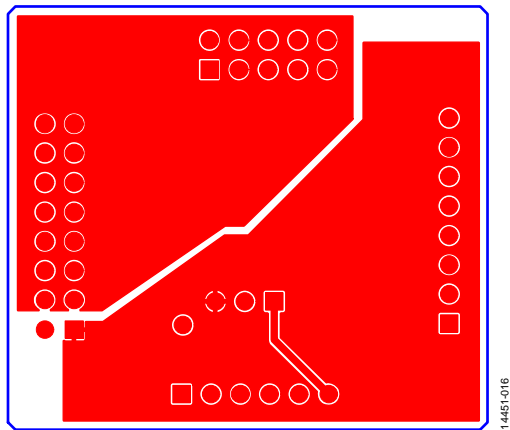

Figure 16. EVAL-AD5321DBZ Daughter Board Bottom Side Routing

ORDERING INFORMATION

BILL OF MATERIALS

Table 5. EVAL-MBnanoDAC-SDZ Motherboard

Reference Designator	Description	Supplier ¹ /Part Number
C1, C6, C7, C9	6.3 V tantalum capacitors (Case A), 10 μ F, \pm 20%	FEC 1190107
C2, C5, C8, C10, C15 to C17	50 V, X7R ceramic capacitors, 0.1 μ F, \pm 10%	FEC 1759122
C3, C4	10 V, X5R ceramic capacitors, 1 μ F, \pm 10%	GRM188R61A105KA61D ²
C11	6.3 V tantalum capacitor (Case A), 4.7 μ F, \pm 20%	FEC 1432350
EXT_REF_1 to EXT_REF_4	Straight PCB mount, SMB jacks, 50 Ω	FEC 1206013
J1	Header, 2.54 mm, 2 \times 8-way	FEC 2308428
J2	Header, 2.54 mm, 2 \times 5-way	FEC 9689583
J3, J7, J8	Headers, 2.54 mm, 1 \times 6-way	FEC 9689508
J4	Header, 2.54 mm, 1 \times 8-way	FEC 1766172
J5	3-pin terminal block	FEC 1667472
J6	2-pin terminal block	FEC 151789
J9	Header, 2.54 mm, 2 \times 4-way	FEC 1667509
J10	120-way connector	FEC 1324660
L1	Inductor, SMD, 600 Ω	FEC 9526862
LK5	6-pin (3 \times 2) 0.1" header and shorting block, 36-pin strip	FEC 148-535 and FEC 150-411
LK6, LK7	4-pin (2 \times 2) 0.1" header and shorting blocks, 36-pin strip	FEC 148-535 and FEC 150-411
REF1 to REF4	10-pin (5 \times 2) 0.1" header and shorting blocks	FEC 1022227 and FEC 150-411
R1	Resistor, surge, 1.6 Ω , 1%, 0603	FEC 1627674
R2, R3	SMD resistors, 100 k Ω , 1%, 0603	FEC 9330402
R5 to R15	SMD resistors, 100 Ω , 1%, 0603	FEC 9330364
U2	3.3 V linear regulator	ADP121-AUJZ33R7
U3	32 k Ω I ² C serial EEPROM	FEC 1331330
U4	5 V reference MSOP	ADR445ARMZ
U5	Ultralow noise XFET [®] voltage reference	ADR431BRZ
U6	4.096 V reference	REF198ESZ
U7	Dual-op amp	AD8616ARZ
U10	Quad-op amp	AD8608ARMZ
U11, U12	Op amp	AD8655ARMZ

¹ FEC refers to Farnell Electronic Component Distributors.

² GRM refers to Murata Manufacturing Company.

Table 6. EVAL-AD5321DBZ Daughterboard

Reference Designator	Description	Supplier/Part Number
C1	0805 capacitor location	Do not insert
C2	50 V, X7R, ceramic capacitor	FEC 1759122
C3	6.3 V tantalum capacitor (Case A)	FEC 1190107
J1	16-pin (2 \times 8) header, inserted from solder side	FEC 2308428
J2	10-pin (2 \times 5) straight header, 2.54 mm pitch	FEC 9689583
J3	6-pin (1 \times 6) straight header, 2.54 mm pitch	FEC 9689508
J5	Header, 2.54 mm, PCB, 1 \times 8-way, inserted from solder side	FEC 1766172
LK1	Jumper block using 3-pin SIP header	FEC 1022248 and FEC 150410
R1	0805 resistor location	Do not insert
U1	12-bit DAC	AD5321BRTZ
VOUT	Red test point	Do not insert

¹ FEC refers to Farnell Electronic Component Distributors.

NOTES

¹²C refers to a communications protocol originally developed by Philips Semiconductors (now NXP Semiconductors).

**ESD Caution**

ESD (electrostatic discharge) sensitive device. Charged devices and circuit boards can discharge without detection. Although this product features patented or proprietary protection circuitry, damage may occur on devices subjected to high energy ESD. Therefore, proper ESD precautions should be taken to avoid performance degradation or loss of functionality.

Legal Terms and Conditions

By using the evaluation board discussed herein (together with any tools, components documentation or support materials, the "Evaluation Board"), you are agreeing to be bound by the terms and conditions set forth below ("Agreement") unless you have purchased the Evaluation Board, in which case the Analog Devices Standard Terms and Conditions of Sale shall govern. Do not use the Evaluation Board until you have read and agreed to the Agreement. Your use of the Evaluation Board shall signify your acceptance of the Agreement. This Agreement is made by and between you ("Customer") and Analog Devices, Inc. ("ADI"), with its principal place of business at One Technology Way, Norwood, MA 02062, USA. Subject to the terms and conditions of the Agreement, ADI hereby grants to Customer a free, limited, personal, temporary, non-exclusive, non-sublicensable, non-transferable license to use the Evaluation Board FOR EVALUATION PURPOSES ONLY. Customer understands and agrees that the Evaluation Board is provided for the sole and exclusive purpose referenced above, and agrees not to use the Evaluation Board for any other purpose. Furthermore, the license granted is expressly made subject to the following additional limitations: Customer shall not (i) rent, lease, display, sell, transfer, assign, sublicense, or distribute the Evaluation Board; and (ii) permit any Third Party to access the Evaluation Board. As used herein, the term "Third Party" includes any entity other than ADI, Customer, their employees, affiliates and in-house consultants. The Evaluation Board is NOT sold to Customer; all rights not expressly granted herein, including ownership of the Evaluation Board, are reserved by ADI. CONFIDENTIALITY. This Agreement and the Evaluation Board shall all be considered the confidential and proprietary information of ADI. Customer may not disclose or transfer any portion of the Evaluation Board to any other party for any reason. Upon discontinuation of use of the Evaluation Board or termination of this Agreement, Customer agrees to promptly return the Evaluation Board to ADI. ADDITIONAL RESTRICTIONS. Customer may not disassemble, decompile or reverse engineer chips on the Evaluation Board. Customer shall inform ADI of any occurred damages or any modifications or alterations it makes to the Evaluation Board, including but not limited to soldering or any other activity that affects the material content of the Evaluation Board. Modifications to the Evaluation Board must comply with applicable law, including but not limited to the RoHS Directive. TERMINATION. ADI may terminate this Agreement at any time upon giving written notice to Customer. Customer agrees to return to ADI the Evaluation Board at that time. LIMITATION OF LIABILITY. THE EVALUATION BOARD PROVIDED HEREUNDER IS PROVIDED "AS IS" AND ADI MAKES NO WARRANTIES OR REPRESENTATIONS OF ANY KIND WITH RESPECT TO IT. ADI SPECIFICALLY DISCLAIMS ANY REPRESENTATIONS, ENDORSEMENTS, GUARANTEES, OR WARRANTIES, EXPRESS OR IMPLIED, RELATED TO THE EVALUATION BOARD INCLUDING, BUT NOT LIMITED TO, THE IMPLIED WARRANTY OF MERCHANTABILITY, TITLE, FITNESS FOR A PARTICULAR PURPOSE OR NON-INFRINGEMENT OF INTELLECTUAL PROPERTY RIGHTS. IN NO EVENT WILL ADI AND ITS LICENSORS BE LIABLE FOR ANY INCIDENTAL, SPECIAL, INDIRECT, OR CONSEQUENTIAL DAMAGES RESULTING FROM CUSTOMER'S POSSESSION OR USE OF THE EVALUATION BOARD, INCLUDING BUT NOT LIMITED TO LOST PROFITS, DELAY COSTS, LABOR COSTS OR LOSS OF GOODWILL. ADI'S TOTAL LIABILITY FROM ANY AND ALL CAUSES SHALL BE LIMITED TO THE AMOUNT OF ONE HUNDRED US DOLLARS (\$100,000). EXPORT. Customer agrees that it will not directly or indirectly export the Evaluation Board to another country, and that it will comply with all applicable United States federal laws and regulations relating to exports. GOVERNING LAW. This Agreement shall be governed by and construed in accordance with the substantive laws of the Commonwealth of Massachusetts (excluding conflict of law rules). Any legal action regarding this Agreement will be heard in the state or federal courts having jurisdiction in Suffolk County, Massachusetts, and Customer hereby submits to the personal jurisdiction and venue of such courts. The United Nations Convention on Contracts for the International Sale of Goods shall not apply to this Agreement and is expressly disclaimed.



Стандарт Электрон Связь

Мы молодая и активно развивающаяся компания в области поставок электронных компонентов. Мы поставляем электронные компоненты отечественного и импортного производства напрямую от производителей и с крупнейших складов мира.

Благодаря сотрудничеству с мировыми поставщиками мы осуществляем комплексные и плановые поставки широчайшего спектра электронных компонентов.

Собственная эффективная логистика и склад в обеспечивает надежную поставку продукции в точно указанные сроки по всей России.

Мы осуществляем техническую поддержку нашим клиентам и предпродажную проверку качества продукции. На все поставляемые продукты мы предоставляем гарантию .

Осуществляем поставки продукции под контролем ВП МО РФ на предприятия военно-промышленного комплекса России , а также работаем в рамках 275 ФЗ с открытием отдельных счетов в уполномоченном банке. Система менеджмента качества компании соответствует требованиям ГОСТ ISO 9001.

Минимальные сроки поставки, гибкие цены, неограниченный ассортимент и индивидуальный подход к клиентам являются основой для выстраивания долгосрочного и эффективного сотрудничества с предприятиями радиоэлектронной промышленности, предприятиями ВПК и научно-исследовательскими институтами России.

С нами вы становитесь еще успешнее!

Наши контакты:

Телефон: +7 812 627 14 35

Электронная почта: sales@st-electron.ru

Адрес: 198099, Санкт-Петербург,
Промышленная ул, дом № 19, литера Н,
помещение 100-Н Офис 331