

CliQ M DIN Rail Power Supply

24V 81.6W 1 Phase / DRM-24V80W1PN



Highlights & Features

- Universal AC input voltage range
- Built-in active PFC and up to 90% efficiency
- Full power from -25°C to +60°C operation @ 5000m or 16400 ft. altitude
- Power Boost of 150% up to 7 seconds
- Advanced Power Boost (APB) – protect system and ensure continuing operation when large inrush current detected due to faulty load on a multiple load connection
- DNV GL and ABS approval for maritime applications
- Built-in DC OK Contact and LED indicator for DC OK/ Overload
- Conformal coating on PCBAs to protect against common dust and chemical pollutants

Safety Standards



CB Certified for worldwide use

Model Number:	DRM-24V80W1PN
Unit Weight:	0.50 kg (1.10 lb)
Dimensions (L x W x D):	124 x 32 x 102 mm (4.88 x 1.26 x 4.02 inch)

General Description

Delta Electronics is introducing one of the slimmest DIN rail industrial power supplies in its class, the CliQ M DIN rail power supply series. To fulfill the demands in maritime applications, the product is designed according to major industrial and maritime (Lloyd's Register) safety standards. Other features include compliance with harmonic current IEC/EN 61000-3-2, class A. In addition to having Power Boost of 150% up to 7 seconds, the CliQ M series is the first in the CliQ family to feature Advanced Power Boost (APB). With multiple loads connected in a system, a large outrush current could be drawn (demanded) due to one fault load. This will be detected by APB. The APB will trip the circuit breaker (circuit breaker with appropriate rating based on the system load) on the current path of the fault load due to high current. This thus prevents the system from shutting down while the other connected current paths continue to operate without interruption. Additionally, the product also includes built-in DC OK contact and LED indicator for DC OK/ Overload.

Model Information

CliQ M DIN Rail Power Supply

Model Number	Input Voltage Range	Rated Output Voltage	Rated Output Current
DRM-24V80W1PN	85-276Vac (88-375Vdc)	24Vdc	3.4A

Model Numbering

DR	M –	24V	80W	1	P	N
DIN Rail	CliQ M Series	Output Voltage	80W series	Single Phase	Advanced Power Boost (APB)	N - Metal Case, without Class I, Div 2 and ATEX approvals

CliQ M DIN Rail Power Supply

24V 81.6W 1 Phase / DRM-24V80W1PN

Specifications

Input Ratings / Characteristics

Nominal Input Voltage		100-240Vac	Applicable for TN-, TT and IT mains networks			
Input Voltage Range		85-276Vac	Continuously operating			
Input Frequency	Nom.	50-60Hz	±3% range (47-63Hz)			
Nominal DC Input Voltage		110-300Vdc				
DC input Voltage Range*		88-375Vdc	Continuously operating			
			100Vac	120Vac	230Vac	
Input Current	Typ.	0.91A	0.76A	0.44A	At 24V, 3.4A. Refer to Fig. 1	
	Max.	1.0A	0.9A	0.6A	At 24V, 3.4A.	
Efficiency	Typ.	90.95%	91.49%	91.31%	At 24V, 3.4A. Refer to Fig. 2	
	Min.	87.10%	90.10%	90.00%	At 24V, 3.4A.	
Average Efficiency	Typ.	89.78%	89.46%	89.64%	At 24V, 0.85A (25% load), 1.7A (50% load), 2.55A (75% load)	
	Min.	88.00%	88.60%	88.30%		
Max Power Dissipation	Typ.	1.19W	1.19W	1.29W	At 24V, 0A. Refer to Fig. 3	
	Max.	1.5W	1.5W	1.5W	At 24V, 0A.	
	Typ.	8.16W	7.63W	7.81W	At 24V, 3.4A. Refer to Fig. 3	
	Max.	9.5W	8.8W	9.1W	At 24V, 3.4A.	
Max Inrush Current (Cold Start)	Typ.	4.08A	4.44	12.3A	Entire temperature range	
	Max.	6.0A	7.0A	13.0A		
Max Inrush Energy (Cold Start)	Max.	2A ² s				
Power Factor	Typ.	0.99	0.98	0.89	At 24V, 3.4A. Refer to Fig. 4	
	Min.	0.95	0.95	0.8	At 24V, 3.4A.	
Crest Factor	Max.	2.1	2.1	2.1	At 24V, 3.4A.	
Leakage Current (Enclosure to Neutral)		< 0.14mA / 0.33mA < 0.20mA / 0.46mA < 0.36mA / 0.95mA			110Vac, 50Hz, TN/TT system / IT system 132Vac, 50Hz, TN/TT system / IT system 264Vac, 50Hz, TN/TT system / IT system	

*Safety approval according to IEC/EN/UL 60950-1.

CliQ M DIN Rail Power Supply

24V 81.6W 1 Phase / DRM-24V80W1PN

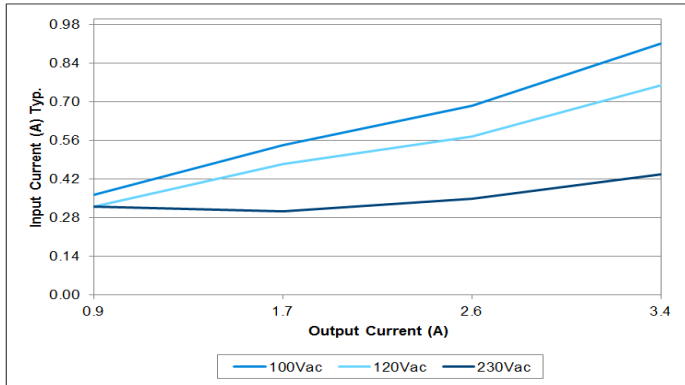

Fig. 1 Input Current Vs Output Load at 24V

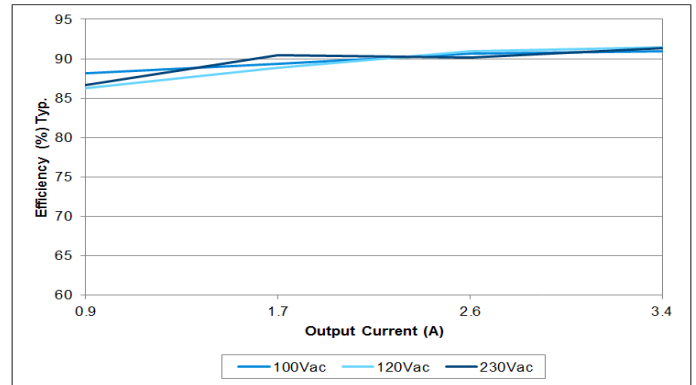

Fig. 2 Efficiency Vs Output Load at 24V

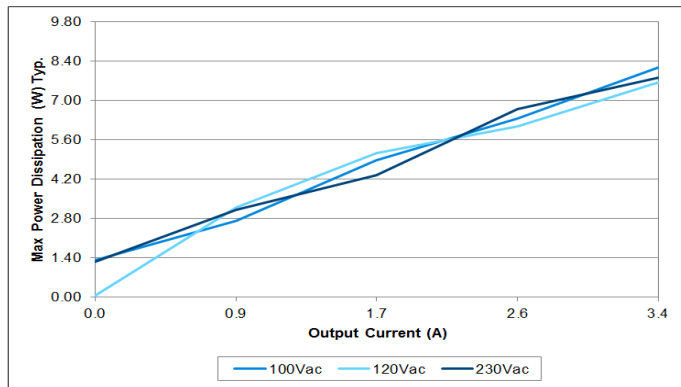

Fig. 3 Max Power Dissipation Vs Output Load at 24V

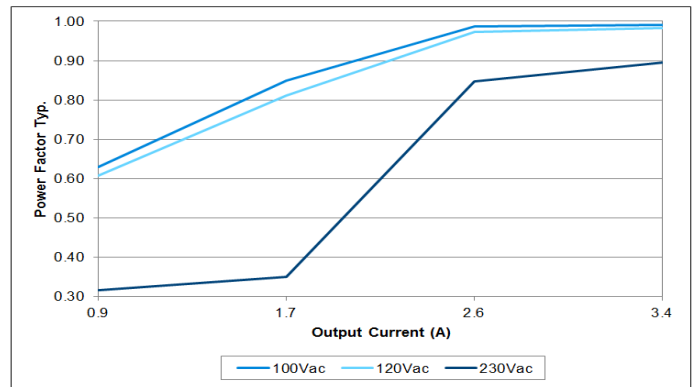

Fig. 4 Power Factor Vs Output Load at 24V

CliQ M DIN Rail Power Supply

24V 81.6W 1 Phase / DRM-24V80W1PN

Output Ratings / Characteristics**

Nominal Output Voltage		24Vdc	
Factory Set Point Tolerance		24Vdc \pm 1.0%	
Output Voltage Adjustment Range		24-28Vdc	
Output Current	Nom. Nom.	3.4A / 3.0A 5.0A / 4.5A (Slew rate 0.1A/ μ s)	Continuously operating at 24V / 28V Power Boost for 5 seconds at 24V / 28V, refer to the details in the Function section
Output Power	Nom. Nom.	81.6W / 84W 120W / 126W	Continuously operating at 24V / 28V Power Boost for 5 seconds at 24V / 28V, refer to the details in the Functions section
Power Boost Duration	Typ. Max.	5 seconds 7 seconds	Duration after which output voltage start to droop, refer to the details in the Function section at Overload & Overcurrent Protections
Power Boost Recovery Time	Typ.	14 seconds	Required wait duration before next Power Boost is taken, refer to the details in the Function section
Advanced Power Boost (Slew rate 0.1A/ μ s)	Typ. Typ. Typ.	6.8A @ 50ms, resistive load 13.5A @ 2ms, resistive load 13.5A @ 5ms, resistive load	Output voltage will drop (Refer to the details in the Function section)
Line Regulation	Max.	10mV (@ 85-276Vac input, 100% load)	
Load Regulation	Max.	100mV (@ 85-276Vac input, 0-100% load)	
PARD***	Max.	50mVpp	20Hz to 20MHz, 50Ohm, warm up for 10mins

**For power de-rating from 60°C to 70°C, see power de-rating on page 10.

***PARD is measured with an AC coupling mode, 5cm wires, and in parallel with 0.1 μ F ceramic capacitor & 47 μ F electrolytic capacitor.

		100Vac	120Vac	230Vac	
Rise Time	Max.	15ms			0 μ F, 24V, 3.4A.
	Max.	55ms			5,000 μ F, 24V, 10A.
Start-up Time	Max.	430ms	370ms	330ms	At 24V, 3.4A.
Hold-up Time	Typ.	79ms	78ms	222ms	At 24V, 1.7A.
	Min.	70ms	70ms	90ms	At 24V, 1.7A.
	Typ.	40ms	40ms	118ms	At 24V, 3.4A.
	Min.	35ms	35ms	70ms	At 24V, 3.4A.
Dynamic Response (Overshoot & Undershoot O/P Voltage)	Max.	\pm 5% @ 0-100% load			Slew rate 0.1A/ μ s (@ 5Hz, 50Hz & 1kHz, 50% Duty Cycle)
Start-up with Capacitive Loads	Max.	8,000 μ F			
Output Capacitance	Typ.	2,150 μ F			Built-in output capacitors
Functional	DC OK Relay Contact	Rated: 30V at 1A, resistive load The relay contact are normally "ON" (closed) when the output (Vout) is greater than 90% of its rated value.			

CliQ M DIN Rail Power Supply

24V 81.6W 1 Phase / DRM-24V80W1PN

Mechanical

Case Cover / Chassis	Aluminium	
Dimensions (L x W x D)	124 x 32 x 102 mm (4.88 x 1.26 x 4.02 inch)	
Unit Weight	0.50 kg (1.10 lb)	
Indicator	Green LED (DC OK) and Red LED (Overload)	
Cooling System	Convection	
Terminal	Input	3 Pins (Rated 600V/35A)
	Output	6 Pins (Rated 300V/8A)
Wire	Input	AWG 20-8
	Output	AWG 22-16
Mounting Rail	Standard TS35 DIN Rail in accordance with EN 60715	
Noise (1 Meter from power supply)	Sound Pressure Level (SPL) < 25dBA	

Environment

Surrounding Air Temperature	Operating	-25°C to +70°C (Cold start -40°C)	
	Storage	-40°C to +85°C	
Power De-rating	Vertical Mounting	> 60°C de-rate power by 2.5% / °C	
	Horizontal Mounting	> 50°C de-rate power by 2.5% / °C	
Operating Humidity	5 to 95% RH (Non-Condensing)		
Operating Altitude	0 to 5,000 Meters (16,400 ft.) for ITE application 0 to 2,500 Meters (8,200 ft.) for Industrial application		
Shock Test (Non-Operating)	IEC60068-2-27, Half Sine Wave: 30G for a duration of 18ms; 3 times per direction, 6 times in total		
Vibration (Non-Operating)	IEC 60068-2-6, Sine Wave: 10-500Hz; 3G peak; displacement of 0.35mm; 60 min per axis for all X, Y, Z directions		
Bump Test (Operating)	IEC 60068-2-29, Half Sine Wave: 10G for a duration of 11ms, 1,000 times per direction, 6,000 times in total		
Over Voltage Category	III	According to EN 50178 / EN 60204-1 (clearance and creepage distances) and IEC 62103 (safety part)	
Pollution Degree	2		

CliQ M DIN Rail Power Supply

24V 81.6W 1 Phase / DRM-24V80W1PN

Protections

Overvoltage	28.8 – 35.2V, SELV Output, Hiccup Mode, Non-Latching (Auto-Recovery)	Refer to the details in the Function section
Overload / Overcurrent	> 150% of rated load current, Constant current limit, Auto-Recovery when the fault is removed	Refer to the details in the Function section
Over Temperature	< 80°C Surrounding Air Temperature @ 100% load, Non-Latching (Auto-Recovery)	Refer to the details in the Function section
Short Circuit	Hiccup Mode, Non-Latching (Auto-Recovery when the fault is removed)	Load impedance \leq 100mOhm, refer to the details in the Function section
Transient Surge Voltage Protection	MOV (Metal Oxide Varistor)	
Internal Fuse	T3.15A	
Degree of Protection	IP20	
Protection Against Shock	Class I with PE* connection	

*PE: Primary Earth

Reliability Data

MTBF (as per Telcordia SR-332)	2,164,300 hrs.	I/P: 100Vac, O/P: 24V, 3.4A, Ta: 25°C	
	1,341,200 hrs.	I/P: 100Vac, O/P: 24V, 3.4A, Ta: 40°C	
Expected Cap Life Time**	100Vac	230Vac	
	131,400hrs.		O/P: 24V, 3.4A, Ta: 25°C
	131,400hrs.		O/P: 24V, 3.4A, Ta: 40°C
	131,400hrs.		O/P: 24V, 1.7A, Ta: 40°C

**Estimated lifetime when 24 hours operating a day and E-cap's manufacturer guarantee at 131,400 hrs (15 years) as maximum limit of lifetime.

CliQ M DIN Rail Power Supply

24V 81.6W 1 Phase / DRM-24V80W1PN

Safety Standards / Directives

Electrical Equipment of Machines		EN 60204-1 (over voltage category III)
Electrical Equipment for Use in Electrical Power Installations		EN 50178 / IEC 62103
Safety Entry Low Voltage		PELV (EN 60204-1), SELV (EN 60950-1)
Electrical Safety	SIQ Bauart UL/cUL recognized CB scheme	EN 60950-1, EN 61558-1, EN 61558-2-16, EN 61010-1, EN 61010-2-201 UL 60950-1 and CSA C22.2 No. 60950-1 (File No. E191395) IEC 60950-1, IEC 61558-1, IEC 61558-2-16, IEC 61010-1, IEC 61010-2-201
Industrial Control Equipment	UL/cUL listed CSA	UL 508 and CSA C22.2 No. 107.1-01 (File No. E315355), CSA C22.2 No. 107.1-01 (File No. 181564)
Maritime	DNV GL ABS	Germanischer Lloyd classified American Bureau for Shipping) PDA Environmental category: C, EMC2
CE		In conformance with EMC Directive 2014/30/EU and Low Voltage Directive 2014/35/EU
Material and Parts		RoHS Directive 2011/65/EU Compliant
Galvanic Isolation	4.54KVac	Input / Output
	2.5KVac	Input / PE
	4.54KVac	Input / DC OK relay contact*
	1.5KVac	Output / PE
	0.5KVac	Output / DC OK relay contact
	1.5KVac	DC OK relay contact / PE
Isolation Resistance	> 5MΩ	Input to Output, 500Vdc
PE Resistance	< 0.1Ω	

*Recommend to connect DC OK pins together with output pins.

CliQ M DIN Rail Power Supply

24V 81.6W 1 Phase / DRM-24V80W1PN

EMC

Emissions (CE & RE)		Generic Standards: EN 61000-6-3 CISPR 32, EN 55032, CISPR 11, EN 55011, FCC Title 47: Class B		
Component Power Supply for General Use		EN 61204-3		
Immunity		EN 55024, EN 61000-6-2		
Electrostatic Discharge	IEC 61000-4-2	Level 4 Criteria A ¹⁾ Air Discharge: 15kV Contact Discharge: 8kV		
Radiated Field	IEC 61000-4-3	Level 3 Criteria A ¹⁾ 80MHz-1GHz, 10V/M, 80% modulation (1kHz) 1.4GHz-2GHz, 10V/M, 80% modulation (1KHz) 2GHz-2.7GHz, 10V/M, 80% modulation (1KHz)		
Electrical Fast Transient / Burst	IEC 61000-4-4	Level 4 Criteria A ¹⁾ 4kV		
Surge	IEC 61000-4-5	Level 4 Criteria A ¹⁾ Common Mode ³⁾ : 4kV Differential Mode ⁴⁾ : 2kV		
Conducted	IEC 61000-4-6	Level 3 Criteria A ¹⁾ 150kHz-80MHz, 10Vrms		
Power Frequency Magnetic Fields	IEC 61000-4-8	Criteria A ¹⁾ 30A/Meter		
Voltage Dips and Interruptions	IEC 61000-4-11	0% of 100Vac 40% of 100Vac 70% of 100Vac 0% of 200Vac 40% of 200Vac 70% of 200Vac 0% of 200Vac	0Vac, 20ms 40Vac, 200ms 70Vac, 500ms 0Vac, 20ms 80Vac, 200ms 140Vac, 500ms 0Vac, 5000ms	Criteria A ¹⁾ Criteria B ²⁾ Criteria A ¹⁾ Criteria A ¹⁾ Criteria A ¹⁾ Criteria A ¹⁾ Criteria B ²⁾
Low Energy Pulse Test (Ring Wave)	IEC 61000-4-12	Level 3 Criteria A ¹⁾ Common Mode ³⁾ : 2kV Differential Mode ⁴⁾ : 1kV		
Harmonic Current Emission		IEC/EN 61000-3-2, Class A		
Voltage Fluctuation and Flicker		IEC/EN 61000-3-3		
Voltage Sag Immunity SEMI F47 – 0706		80% of 120Vac 70% of 120Vac 50% of 120Vac	96Vac, 1000ms 84Vac, 500ms 60Vac, 200ms	Criteria A ¹⁾ Criteria A ¹⁾ Criteria A ¹⁾

1) Criteria A: Normal performance within the specification limits
 2) Criteria B: Temporary degradation or loss of function which is self-recoverable
 3) Asymmetrical: Common mode (Line to earth)
 4) Symmetrical: Differential mode (Line to line)

CliQ M DIN Rail Power Supply

24V 81.6W 1 Phase / DRM-24V80W1PN

Block Diagram

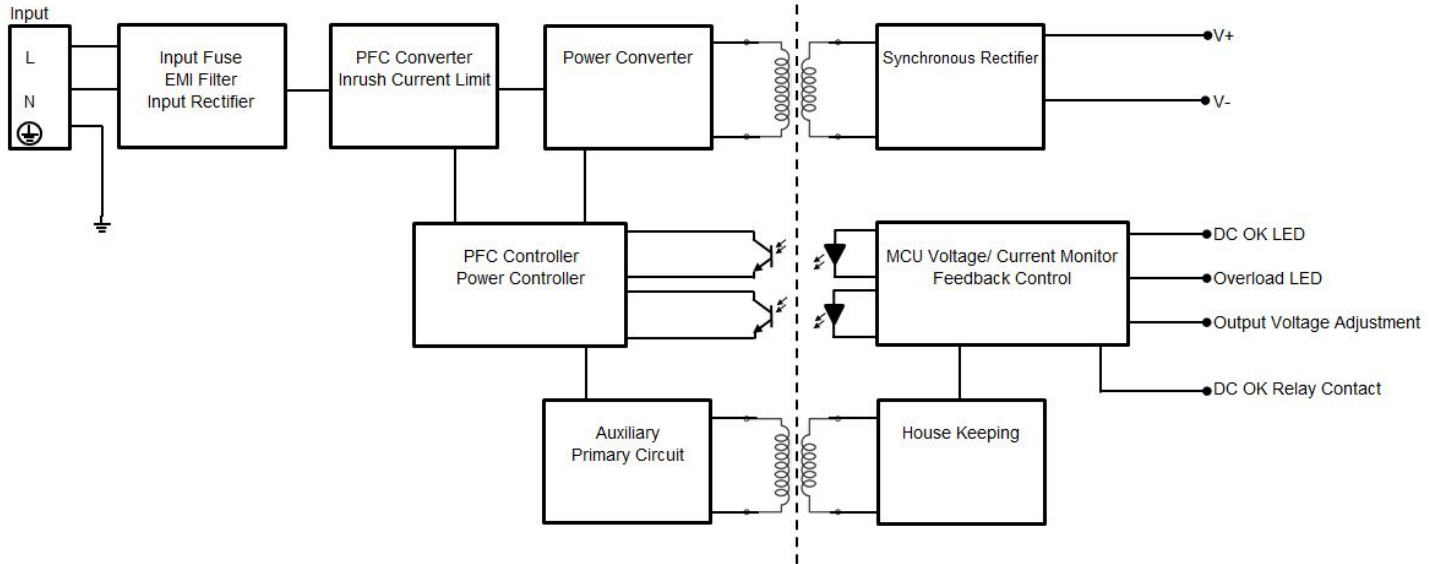

Device Description

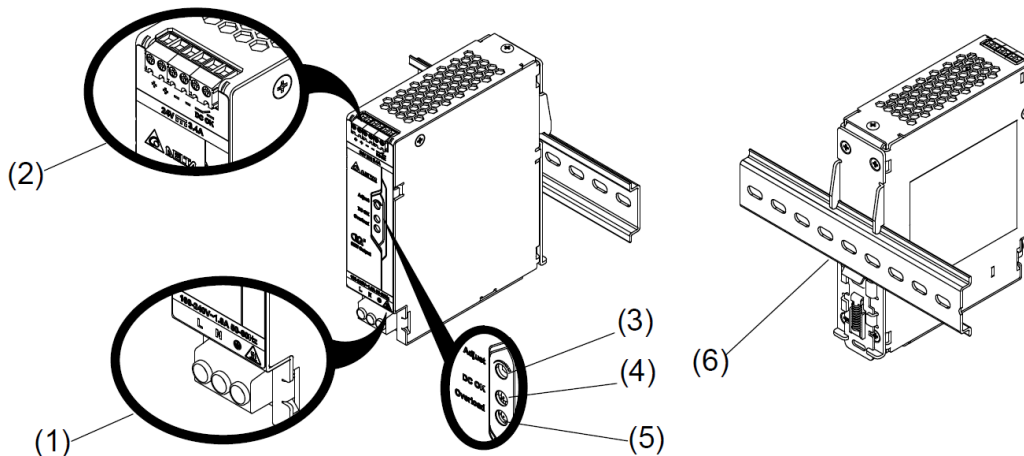

- 1) Input terminal block connector
- 2) Output and DC OK relay contact terminal block connector
- 3) DC Voltage adjustment potentiometer
- 4) DC OK LED (Green)
- 5) Overload LED (Red)
- 6) Universal mounting rail system

CliQ M DIN Rail Power Supply

24V 81.6W 1 Phase / DRM-24V80W1PN

Dimensions

L x W x D: 124 x 32 x 102 mm (4.88 x 1.26 x 4.02 inch)

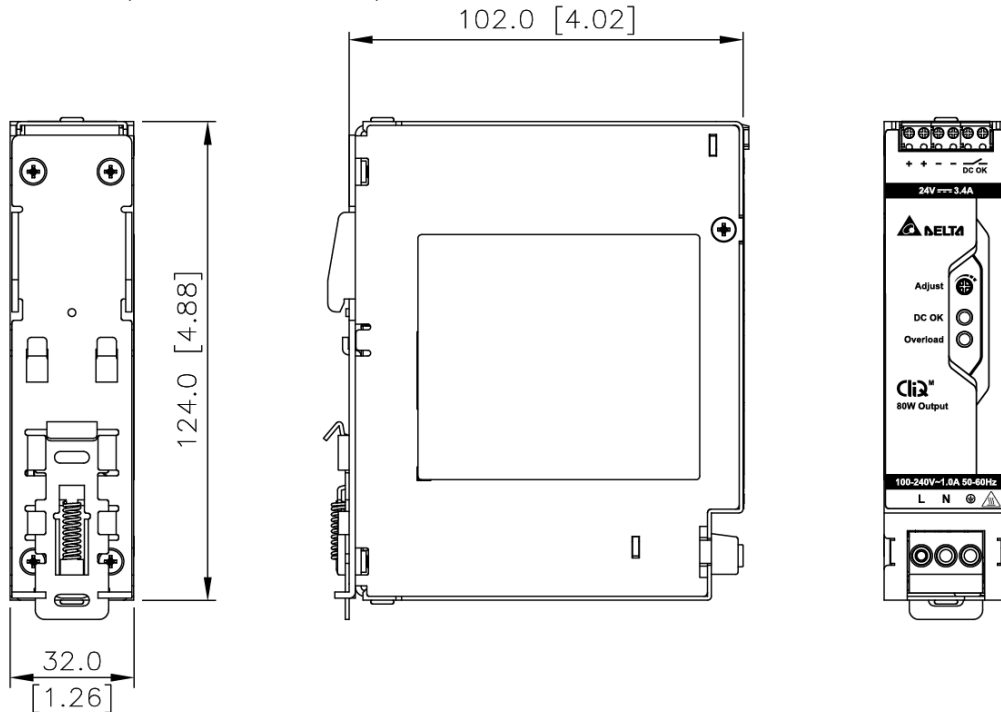

Engineering Data

Output Load De-rating VS Surrounding Air Temperature

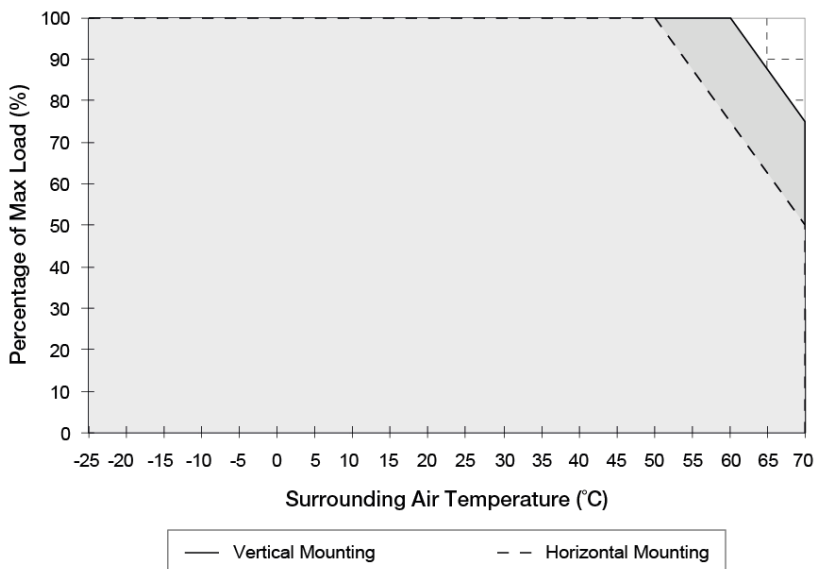

Fig. 5 De-rating for Vertical Mounting Orientation
 > 60°C de-rate power by 2.5% / °C

De-rating for Horizontal Mounting Orientation
 > 50°C de-rate power by 2.5% / °C

Note

1. Power supply components may degrade, or be damaged, when the power supply is continuously used outside the shaded region, refer to the graph shown in Fig. 5.
2. If the output capacity is not reduced when the surrounding air temperature exceeds its specification as defined on Page 5 under "Environment", the device will run into Over Temperature Protection. When activated, the output voltage will go into bouncing mode and will recover when the surrounding air temperature is lowered or the load is reduced as far as necessary to keep the device in working condition.
3. In order for the device to function in the manner intended, it is also necessary to keep a safety distance as recommended in the safety instructions while the device is in operation.
4. Depending on the surrounding air temperature and output load delivered by the power supply, the device can be very hot!
5. If the device has to be mounted in any other orientation, please contact info@deltapsu.com for more details.

CliQ M DIN Rail Power Supply

24V 81.6W 1 Phase / DRM-24V80W1PN

Output Load De-rating VS Input Voltage

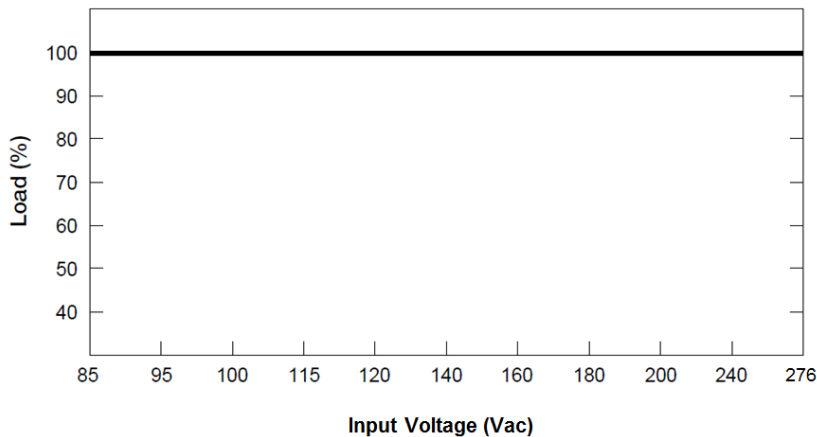

■ No output power de-rating for the input voltage range

Assembly & Installation

The power supply unit (PSU) can be mounted on 35mm DIN rails in accordance with EN 60715. For Vertical Mounting, the device should be installed with input terminal block at the bottom. For Horizontal Mounting, the device should be installed with input terminal block on the left side.

Each device is delivered ready to install.

1. Tilt the unit upwards and insert it onto the DIN rail. Snap on the DIN rail as shown in Fig. 6.1.
2. Push downwards until stopped.
3. Press against the bottom front side for locking.
4. Shake the unit slightly to ensure that it is secured.
5. To uninstall, pull or slide down the latch with screw driver as shown in Fig. 6.2. Then slide the power supply unit (PSU) in the opposite direction, release the latch and pull out the power supply unit (PSU) from the rail.

Mounting

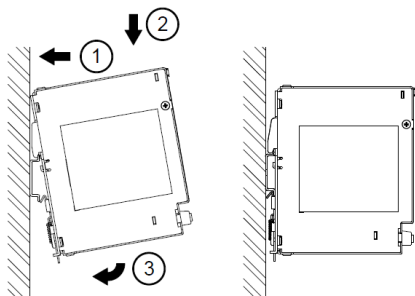

Fig. 6.1 Mounting

Dismounting

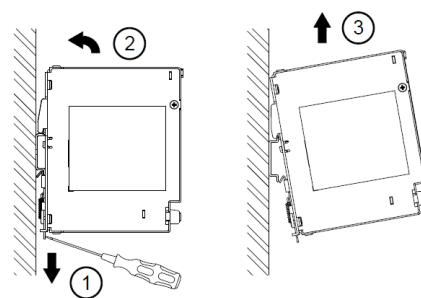

Fig. 6.2 Dismounting

In accordance to EN 60950 / UL 60950, flexible cables require ferrules. Use appropriate copper cables designed to sustain operating temperature of:

1. 60°C, 60°C / 75°C for USA
2. At least 90°C for Canada and IEC/EN61010-1, IEC/EN61010-2-201.

CliQ M DIN Rail Power Supply

24V 81.6W 1 Phase / DRM-24V80W1PN

Safety Instructions

■ Vertical Mounting

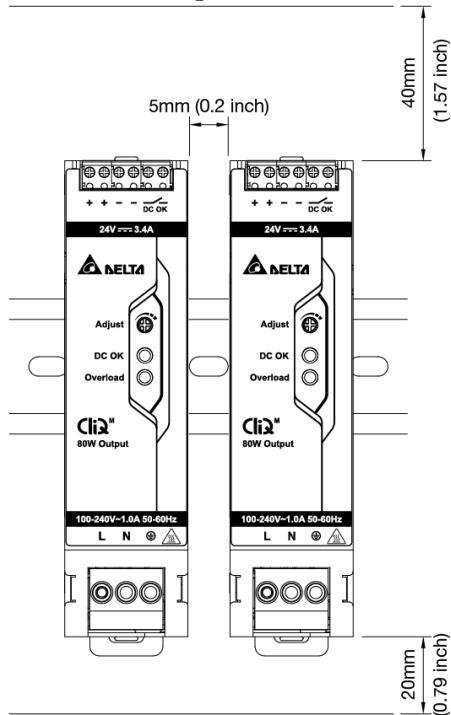

■ Horizontal Mounting

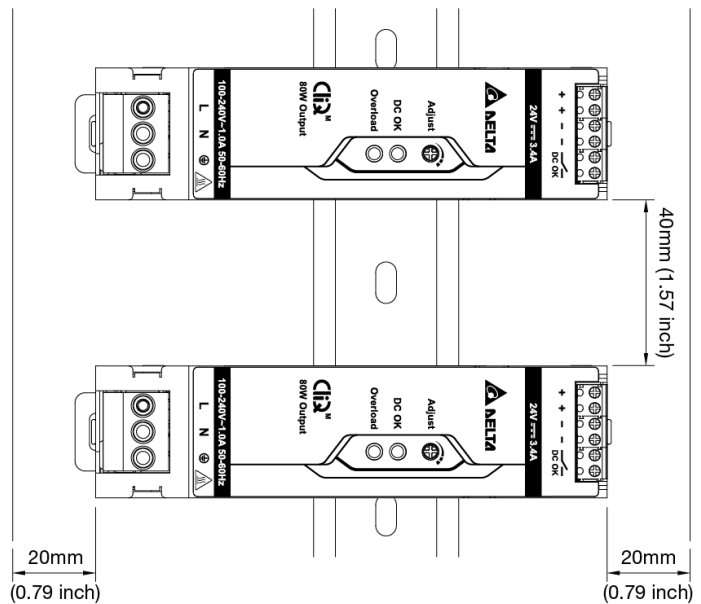

- ALWAYS switch mains of input power OFF before connecting and disconnecting the input voltage to the device. If mains are not turned OFF, there is risk of explosion / severe damage.
- If the unit is used in a manner not specified by the manufacturer, the protection provided by the equipment may be impaired.
- **To guarantee sufficient convection cooling, please refer to the following instructions to ensure sufficient clearance around the device.**

Vertical Mounting: 40mm (1.57 inch) above and 20mm (0.79 inch) below the device as well as a lateral distance of 5mm (0.2 inch) to other units. In case the adjacent device is a heat source, the lateral distance will be 15mm (0.6 inch).

Horizontal Mounting: 40mm (1.57 inch) above and below the device as well as a lateral distance of 20mm (0.79 inch) to other units.

- The external enclosure where the unit will be installed shall meet the requirements for mechanical, electrical and fire enclosure.
- Note that the enclosure of the device can become very hot depending on the surrounding air temperature and output load connected to the device. Risk of burns!
- The main power must be turned off before connecting or disconnecting wires to the terminals.
- DO NOT insert any objects into the unit.
- Dangerous voltages present for at least 5 minutes after disconnected all sources of power.
- The power supplies are built in units and must be installed in a cabinet or room (condensation free environment and indoor location) that is relatively free of conductive contaminants.

CliQ M DIN Rail Power Supply

24V 81.6W 1 Phase / DRM-24V80W1PN

Functions

DC OK Relay Contacts and LED Indicator Characteristics

CliQ M Status	DC OK (Green LED)	Overload (Red LED)	DC OK Relay Contact
Normal Operation	ON	OFF	Closed
During Power Boost	ON	OFF	Closed
Overload (Vout ≤ 90% of adjusted voltage)	OFF	ON	Open
Output Short Circuit	OFF	Flashing	Open
Over Temperature	Flashing	Flashing	Open
No Input Power	OFF	OFF	Open

■ Graph illustrating the Start-up Time, Rise Time, and Hold-up Time

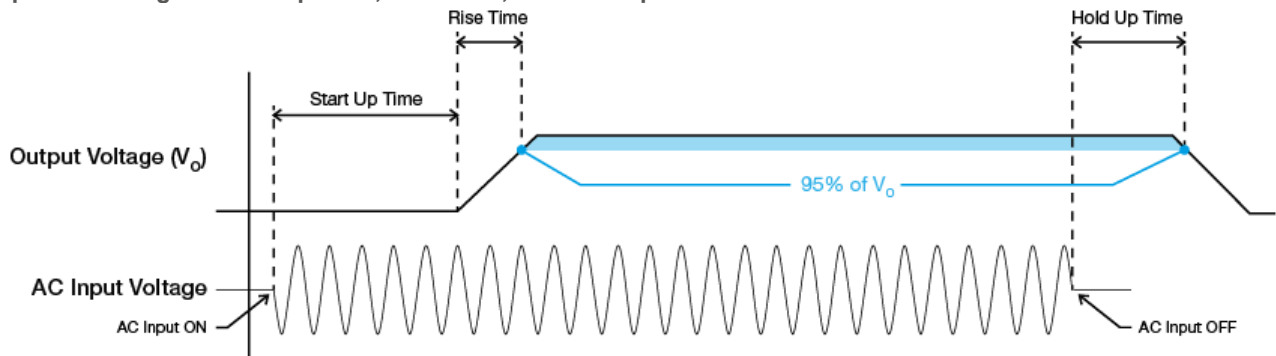

Start-up Time

The time required for the output voltage before output voltage rise up, after the input voltage is applied.

Rise Time

The time required for the output voltage to change from 0% to 95% of its final steady state set value.

Hold-up Time

Time between the collapse of the AC input voltage, and the output falling to 95% of its steady state set value.

CliQ M DIN Rail Power Supply

24V 81.6W 1 Phase / DRM-24V80W1PN

Inrush Current

Inrush current is the peak, instantaneous, input current measured and, occurs when the input voltage is first applied. For AC input voltages, the maximum peak value of inrush current will occur during the first half cycle of the applied AC voltage. This peak value decreases exponentially during subsequent cycles of AC voltage.

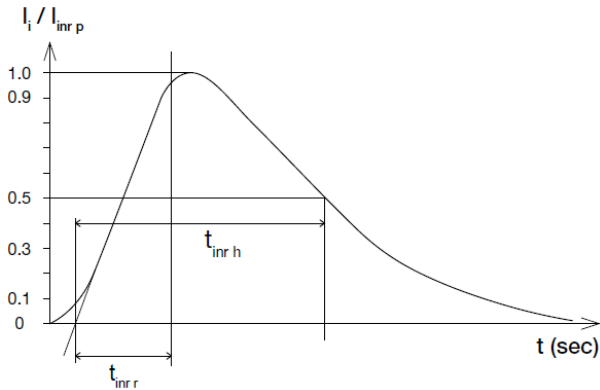

Dynamic Response

The power supply output voltage will remain within $\pm 5\%$ of its steady state value, when subjected to a dynamic load from 0% to 100% of its rated current.

■ 50% duty cycle / 5Hz to 1KHz

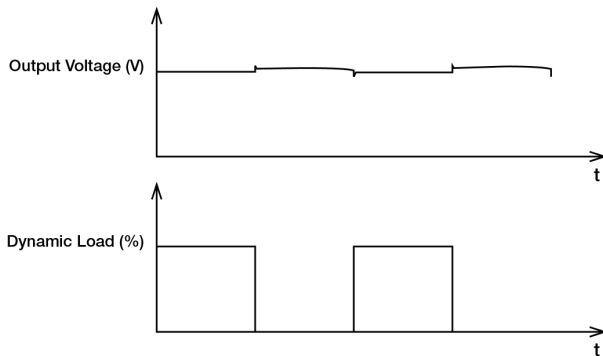

Overvoltage Protection (Auto-Recovery)

The power supply's overvoltage circuit will be activated when its internal feedback circuit fails. The output voltage shall not exceed its specifications defined on Page 6 under "Protections".

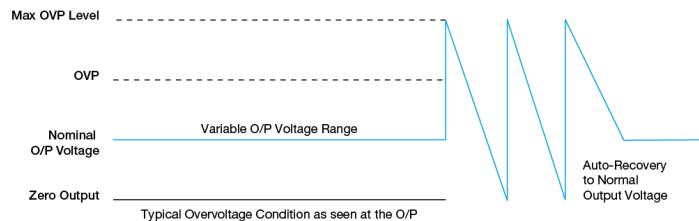

Overload & Overcurrent Protections (Auto-Recovery)

The power supply's Overload (OLP) and Overcurrent (OCP) Protections will be activated when output current is $> 150\%$ of I_o (output current). Upon such an occurrence, V_o (output voltage) will start to droop, refer to (C) and after 7 sec output current will limit to 4.6A typ., refer to (A). Once V_o is below 11Vdc typ., the power supply will operate in "Hiccup mode". The power supply will recover once the fault condition due to OLP or OCP is removed, then I_o is back within the specified range.

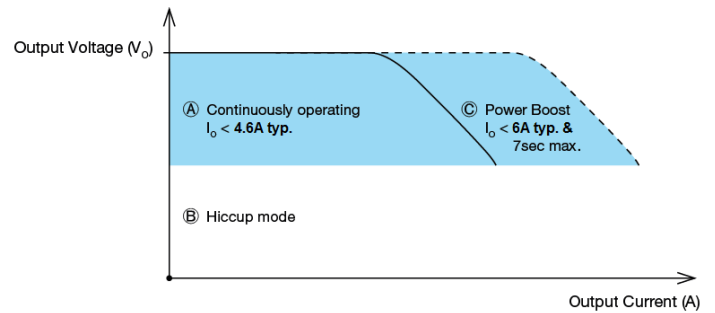

Short Circuit Protection (Auto-Recovery)

The power supply's output Short Circuit Protection function also provides protection against short circuits. When a short circuit is applied, the output current will operate in "Hiccup mode". The power supply will return to normal operation after the short circuit is removed.

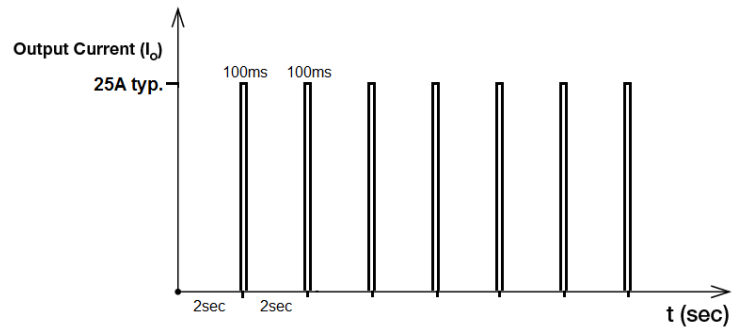

Over Temperature Protection (Auto-Recovery)

As described in load de-rating section, the power supply also has Over Temperature Protection (OTP). In the event of a higher operating temperature at 100% load, the power supply will run into OTP when the operating temperature is beyond what is recommended in the de-rating graph. When activated, the output voltage will go into bouncing mode until the temperature drops to its normal operating temperature as recommended in the de-rating graph.

CliQ M DIN Rail Power Supply

24V 81.6W 1 Phase / DRM-24V80W1PN

Power Boost

Power Boost is the reserve power available constantly that allows reliable startup to support sudden and short spike of loads with high inrush current typically during turn on to remove the need of more expensive higher rated power supply unit. After the output has reached its steady state set value, the power supply can support surge loads with a higher short-term power demand up to 150% of maximum rated load (I_o Max), for a maximum duration of 7 seconds. If the power boost lasts longer than maximum duration, the output current will limit to 4.6A typ. and V_o (output voltage) will start to droop. Once V_o is below 11Vdc typ., the power supply will operate in "Hiccup mode". The Power Boost is repetitive, need to maintain the duty cycle & recovery time to ensure that average (R.M.S) output power shall not exceed the continuous maximum, see duty cycle calculation below.

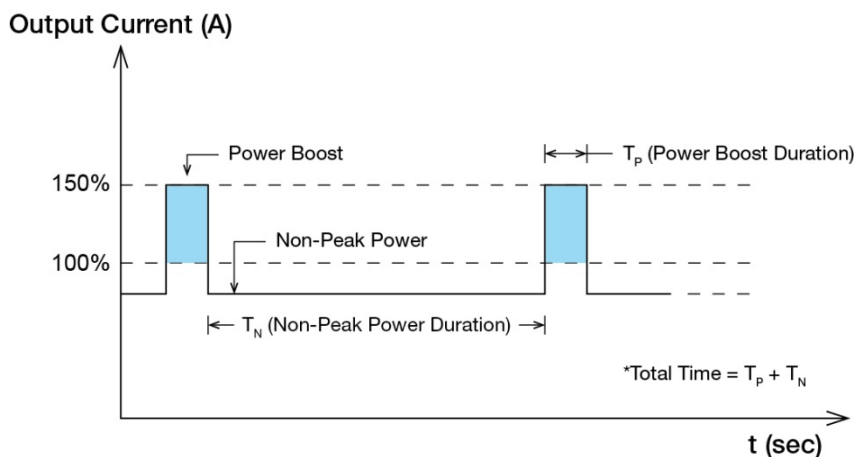

Fig. 7 Duty Cycle Calculation

$$Duty\ cycle\ (\%) = \frac{T_P}{Total\ Time}$$

$$Average\ Output\ Power\ (P_{Avg}) = \frac{(Power\ Boost \times T_P) + (Non-Peak\ Power \times T_N)}{Total\ Time}$$

OR

$$Non-Peak\ Power = \frac{(P_{Avg} \times Total\ Time) - (Power\ Boost \times T_P)}{T_N}$$

■ An example of Power Boost and Average Output Power

Power Boost	Peak Power (W _P)	Power Boost Duration (T _P)	Duty Cycle	Non-Peak Power (W _N)	Non-Peak Power Duration (T _N)	Total Time (T)
150%	120	7 sec	10%	75W	60 sec	67 sec
150%	120	7 sec	30%	63W	16 sec	23 sec
120%	96	7 sec	10%	78W	60 sec	67 sec
120%	96	7 sec	30%	73W	16 sec	23 sec

It is not recommended to extend the duration of Power Boost to be longer than the specified duty cycle calculation, this may cause damage to the PSU.

CliQ M DIN Rail Power Supply

24V 81.6W 1 Phase / DRM-24V80W1PN

Advanced Power Boost (APB)

With multiple loads connected in a system and due to one of fault load a large outrush current is drawn (demanded), this will be detected by APB. This APB can trip the external output protection device with appropriate rating based on system load. Thus preventing the system from shutting down while other connected current paths continue to operate without interruption.

The following waveforms demonstrate the behavior.

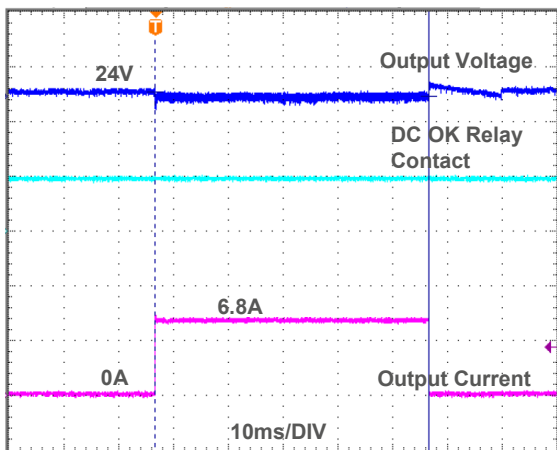

Fig. 8.1 APB 200% of nominal output current for 50ms

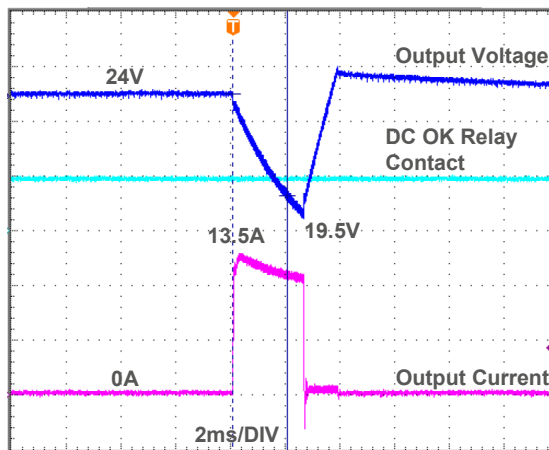

Fig. 8.2 APB 400% of nominal output current for 2ms

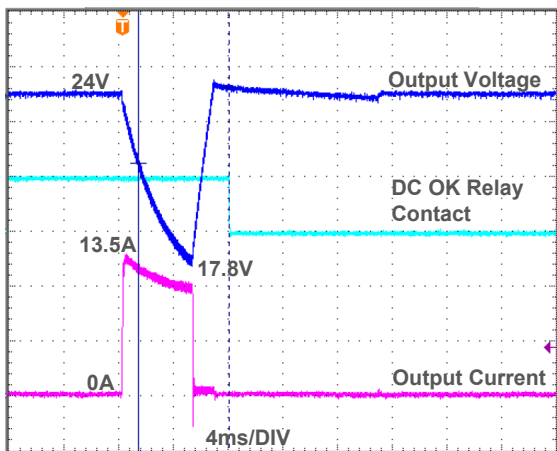

Fig. 8.3 APB 400% of nominal output current for 5ms

External Input Protection Device

The unit is protected at the L pin, with an internal fuse that cannot be replaced. The power supply has been tested and approved on 20A (UL) and 16A (IEC) branch circuits without additional protection device. An external protection device is only required if the supplying branch has an ampacity greater than above. Thus, if an external protective device is necessary, or, utilized, please refer a minimum value in instruction sheet with B or C characteristic breaker.

CliQ M DIN Rail Power Supply

24V 81.6W 1 Phase / DRM-24V80W1PN

Operating Mode

■ Redundant Operation

In order to ensure proper redundant operation for the power supply units (PSUs), the output voltage difference between the two units must be kept at 0.45~0.50V for these 24V supplies. Follow simple steps given below to set them up for the redundant operation:

Step 1.

Measure output voltage of PSU 1 and PSU 2. If PSU 1 is the master unit, then V_O of PSU 1 must be higher than PSU 2. In order to set the output voltage, individually connect each power supply to 50% of rated load at any line input voltage, and set the PSU 1 and PSU 2 output voltage.

Step 2.

Connect the power supply units PSU 1 and PSU 2 to $V_{in 1}$ & $V_{in 2}$, respectively, of the DRR-20N (or 20A) module shown on the right of above diagram.

Step 3.

Connect the system load to V_{out} . Please note that output voltage V_{out} from DRR module will be = V_O (output voltage of power supply) – V_{drop}^* (in DRR module).

* V_{drop} will vary from 0.60V to 0.90V (Typical 0.65V) depending on the load current and surrounding air temperature.

■ Parallel Operation

The power supply units (PSUs) can also be used for parallel operation in order to increase the output power. The difference in output voltage between the two units must be kept to within 25mV of each other. This difference must be verified with the same output load connected independently to each unit.

Parameters such as EMI, inrush current, leakage current, PARD, start up time will be different from those on the datasheet, when two units are connected in parallel. The user will need to verify that any differences will still allow the two power supplies connected in parallel will work properly in their product/application.

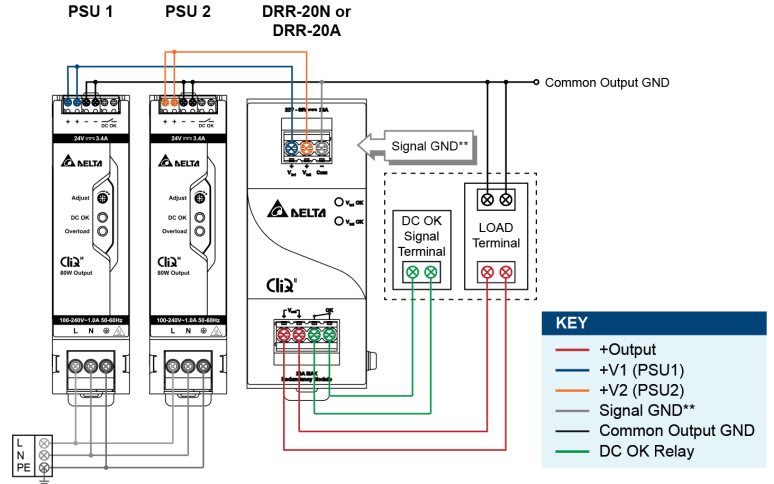

**The Signal GND in the DRR module is for the built-in LED and DC OK signals. The Output GND terminals from the two PSU's do not need to be connected to the Signal GND terminal.

Fig. 9 Redundant Operation Connection Diagram

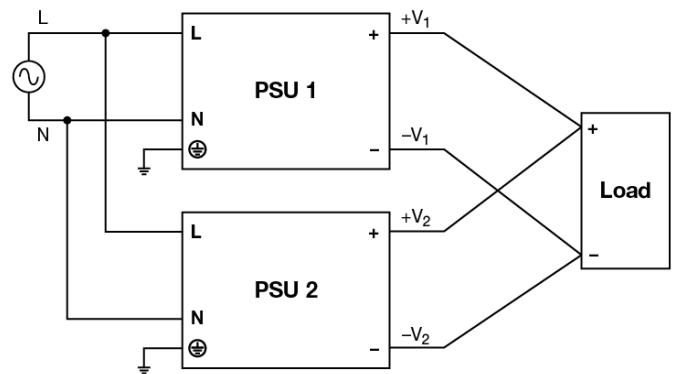

Fig. 10 Parallel Operation Connection Diagram

CliQ M DIN Rail Power Supply

24V 81.6W 1 Phase / DRM-24V80W1PN

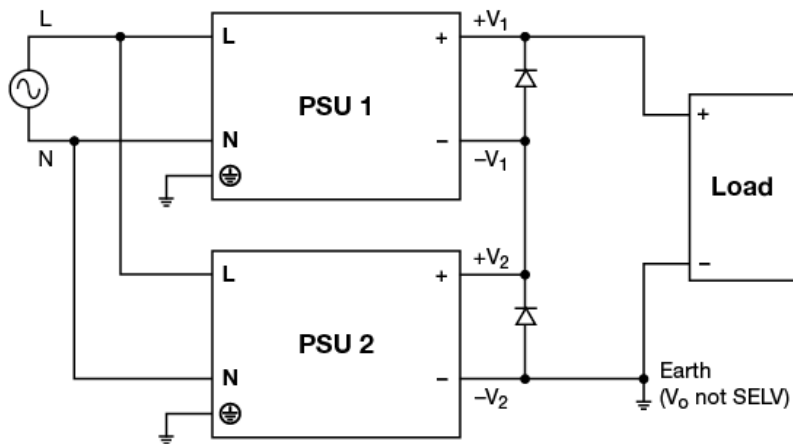
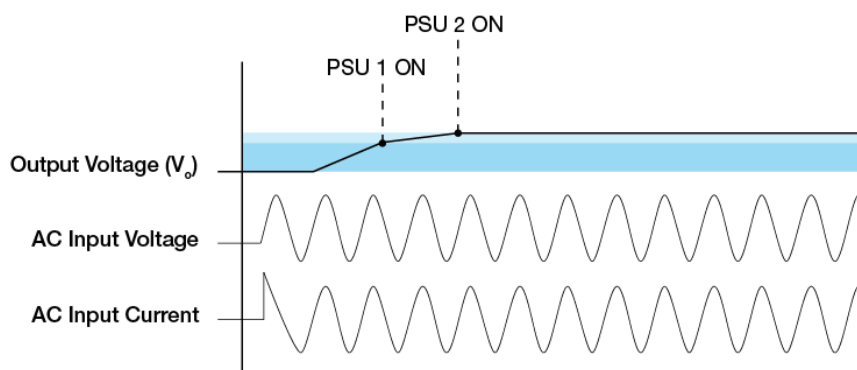

Fig. 11 Series Operation Connection Diagram

Series Operation

Delta's CliQ M can be connected in series to increase the output voltage as shown in figure above. Power supply from the same product series only be used and with the same rated output current. The maximum load current should not exceed the smallest rated output current. Any number of power supplies can be connected in series, user must note that output voltage > 60Vdc will not meet SELV requirements and could be dangerous to user, the total voltage shall not exceed 150Vdc. Installation a protection against the touching is a must and connect the output ground to earth when output voltage is not SELV. A diode in reverse bias must be added across output terminals of each power supply, this is to prevent -V voltage being applied to other power supply in fault conditions such as short circuit across load. During short circuit -V₁ & +V₁ will come across +V₂ & -V₂ which means connecting 2 power supplies in opposite polarity and may cause damage to power supply. With reverse bias diodes in place the voltage across each power supply will be restricted to one diode drop – approximately 0.7V to 1.0V. It is recommended to provide sufficient de-rating for diodes use 2 times the voltage rating of series output voltage. E.g. the two 24V power supplies are connected in series, the total voltage is 48 volts. Hence, recommended to use diodes with reverse voltage rating of 2x48=96 volts. Therefore diodes with reverse voltage rating of 100 volts can be used.

During the short circuit condition, the current through diodes will be large, hence it is recommended that diodes to be least twice the current rating of the power supply.



The turn ON would be non-monotonic as the power supply with the fastest startup time and rise time will turn on first. As a result, the startup waveform with 2 power supplies connected in series would see a step.

User must consider to verify parameters such as EMI, inrush current, leakage current, PARD, start up time would differ from datasheet numbers as multiple power supplies in series.

CliQ M DIN Rail Power Supply

24V 81.6W 1 Phase / DRM-24V80W1PN

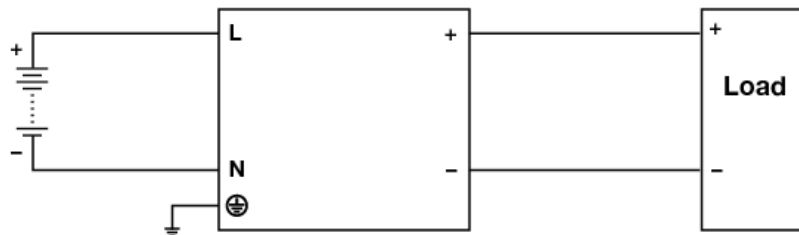

Fig. 12 DC Input Operation Connection Diagram

■ DC Input Operation

Step 1.

Use a battery or similar DC source.

Step 2.

Connect +pole to L and -pole to N.

Step 3.

Connect the PE terminal to an earth wire or to the machine ground.

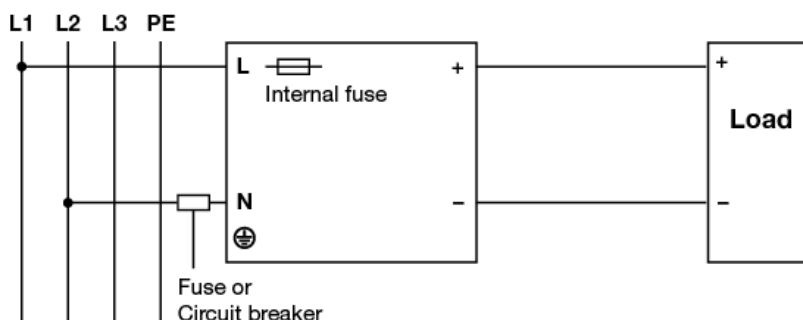

Fig. 13 2 of 3 Phase System Input Operation Connection Diagram

■ 2 of 3 Phase System Input Operation

Delta's CliQ M can use on 2 of 3 phase system. Please refer to the following step.

Step 1.

The supplying voltage is below the maximum rated input. The input voltage shall be below 240Vac +10%.

Step 2.

The external protector is needed on N input line to secure a safety. N line has no protection of a fuse internally. An appropriate fuse or circuit breaker should be connected on N input line like the following.

CliQ M DIN Rail Power Supply

24V 81.6W 1 Phase / DRM-24V80W1PN

Others

Delta RoHS Compliant



Restriction of the usage of hazardous substances

The European directive 2011/65/EU limits the maximum impurity level of homogeneous materials such as lead, mercury, cadmium, chrome, polybrominated flame retardants PBB and PBDE for the use in electrical and electronic equipment. RoHS is the abbreviation for “Restriction of the use of certain hazardous substances in electrical and electronic equipment”.

This product conforms to this standard.

Conformal Coating

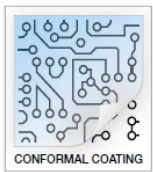

The Protective Coating Technology

Delta Electronics Group has designed the perfect dipping technique which penetrates everywhere including under device, and prevents leakage. The conformal coating dipping can be applied to PCBAs or circuit board. The coating preserves the performance of precision electronic primarily by preventing ionizable contaminants such as salt from reaching circuit nodes, where the material slumps around sharp edges. This can be a problem especially in highly conversing atmosphere.

PFC – Norm EN 61000-3-2



Line Current Harmonic content

Typically, the input current waveform is not sinusoidal due to the periodical peak charging of the input capacitor. In industrial environment, complying with EN 61000-3-2 is only necessary under special conditions. Complying to this standard can have some technical drawbacks, such as lower efficiency as well as some commercial aspects such as higher purchasing costs. Frequently, the user does not profit from fulfilling this standard, therefore, it is important to know whether it is mandatory to meet this standard for a specific application.

Attention

Delta provides all information in the datasheets on an “AS IS” basis and does not offer any kind of warranty through the information for using the product. In the event of any discrepancy between the information in the catalog and datasheets, the datasheets shall prevail (please refer to www.DeltaPSU.com for the latest datasheets information). Delta shall have no liability of indemnification for any claim or action arising from any error for the provided information in the datasheets. Customer shall take its responsibility for evaluation of using the product before placing an order with Delta.

Delta reserves the right to make changes to the information described in the datasheets without notice.



Стандарт Электрон Связь

Мы молодая и активно развивающаяся компания в области поставок электронных компонентов. Мы поставляем электронные компоненты отечественного и импортного производства напрямую от производителей и с крупнейших складов мира.

Благодаря сотрудничеству с мировыми поставщиками мы осуществляем комплексные и плановые поставки широчайшего спектра электронных компонентов.

Собственная эффективная логистика и склад в обеспечивает надежную поставку продукции в точно указанные сроки по всей России.

Мы осуществляем техническую поддержку нашим клиентам и предпродажную проверку качества продукции. На все поставляемые продукты мы предоставляем гарантию .

Осуществляем поставки продукции под контролем ВП МО РФ на предприятия военно-промышленного комплекса России , а также работаем в рамках 275 ФЗ с открытием отдельных счетов в уполномоченном банке. Система менеджмента качества компании соответствует требованиям ГОСТ ISO 9001.

Минимальные сроки поставки, гибкие цены, неограниченный ассортимент и индивидуальный подход к клиентам являются основой для выстраивания долгосрочного и эффективного сотрудничества с предприятиями радиоэлектронной промышленности, предприятиями ВПК и научно-исследовательскими институтами России.

С нами вы становитесь еще успешнее!

Наши контакты:

Телефон: +7 812 627 14 35

Электронная почта: sales@st-electron.ru

Адрес: 198099, Санкт-Петербург,
Промышленная ул, дом № 19, литера Н,
помещение 100-Н Офис 331