

Ordering Information

| Part Number | Option | Package | Surface Mount | Tape & Reel | IEC/EN/DIN EN 60747-5-5 | Quantity |
|-------------|------------------|---------|---------------|-------------|-------------------------|--------------|
| | (RoHS Compliant) | | | | | |
| ACPL-335J | -000E | SO-16 | X | | X | 45 per tube |
| ACPL-335J | -500E | | X | X | X | 850 per reel |

To order, choose a part number from the Part Number column and combine with the desired option from the RoHS Compliant column to form an order entry.

Example 1:

ACPL-335J-500E to order product of SO-16 Surface Mount package in Tape and Reel packaging with IEC/EN/DIN EN 60747-5-5 Safety Approval in RoHS compliant.

Option datasheets are available. Contact your Avago sales representative or authorized distributor for information.

Package Outline Drawings

16-Lead Surface Mount

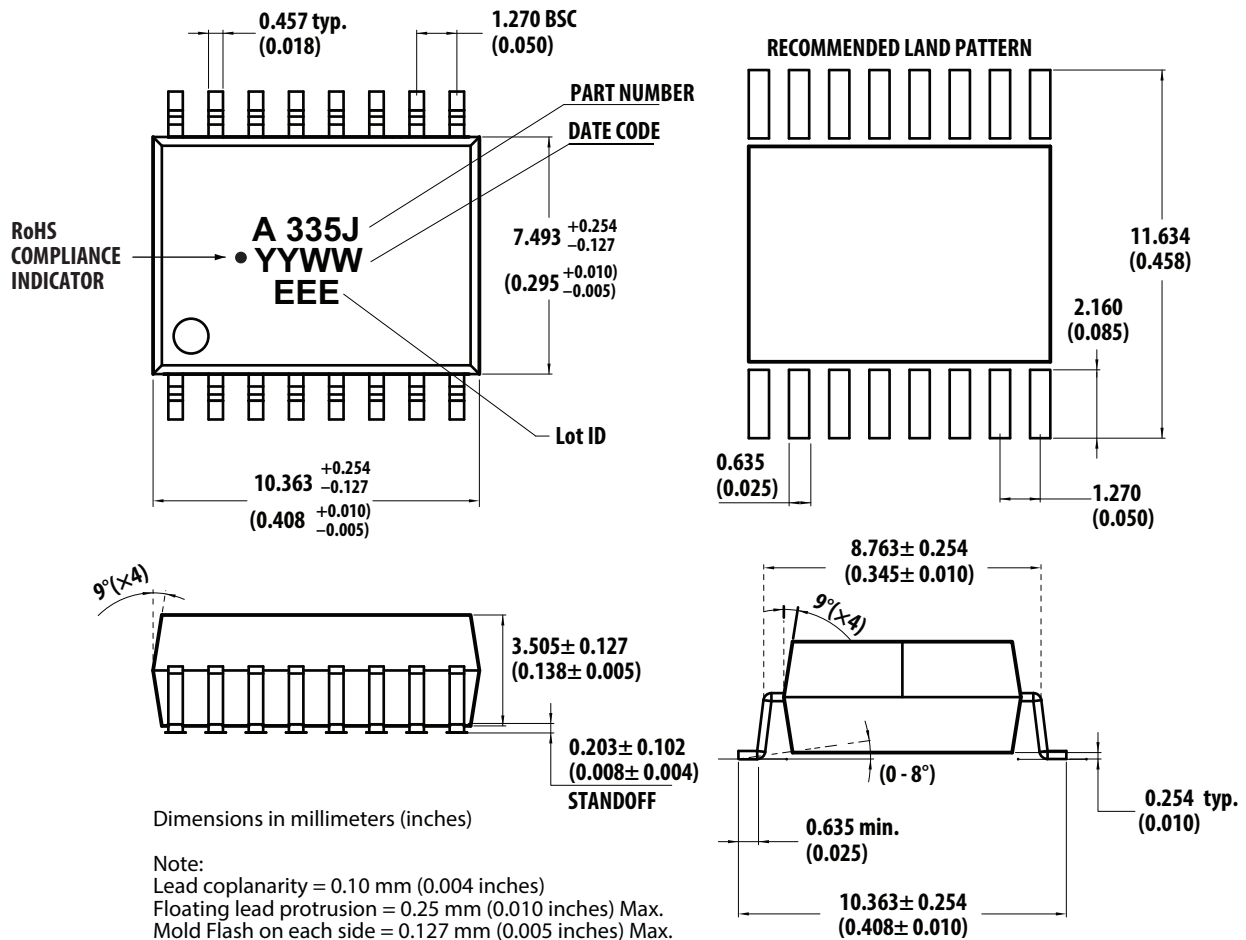

Recommended Lead-free IR Profile

Recommended reflow condition as per JEDEC Standard, J-STD-020 (latest revision).

Non-halide flux should be used.

Product Overview Description

The ACPL-335J (shown in Figure 1) is a highly integrated power control device that incorporates all the necessary components for a complete, isolated MOSFET gate drive circuit. It features desaturation sensing with shutdown protection and fault feedback, under voltage lock-out and feedback and active Miller current clamping in a SO-16 package. Direct LED input allows flexible logic configuration and differential current mode driving with low input impedance, greatly increased its noise immunity.

Package Pin Out

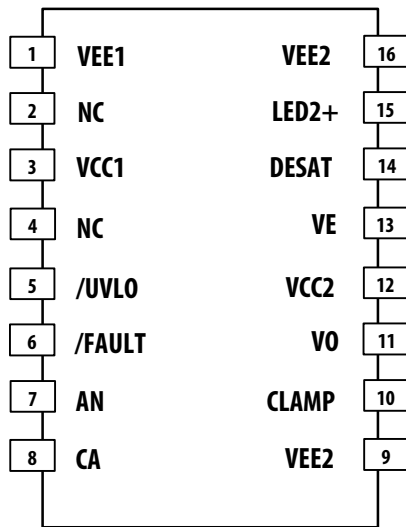

Pin Description

| Pin Name | Function | Pin Name | Function |
|----------|--------------------------------------|----------|---------------------------------|
| VEE1 | Input common | VEE2 | Negative power supply |
| NC | No connection | LED2+ | No connection, for testing only |
| VCC1 | Input power supply | DESAT | Desat over current sensing |
| NC | No connection | VE | MOSFET Source reference |
| /UVLO | VCC2 under voltage lock-out feedback | VCC2 | Positive power supply |
| /FAULT | Over current fault feedback | VO | Driver output to MOSFET gate |
| AN | Input LED anode | CLAMP | Miller current clamping output |
| CA | Input LED cathode | VEE2 | Negative power supply |

Regulatory Information

The ACPL-335J is approved by the following organizations:

| | |
|--------------------------------|--|
| UL | Approved under UL 1577, component recognition program up to $V_{ISO} = 5000 V_{RMS}$ |
| CSA | Approved under CSA Component Acceptance Notice #5, File CA 88324. |
| IEC/EN/DIN EN 60747-5-5 | Approved under IEC 60747-5-5, EN 60747-5-5, DIN EN 60747-5-5 |

IEC/EN/DIN EN 60747-5-5 Insulation Characteristics

| Description | Symbol | Characteristic | Unit |
|---|----------------|---------------------------------------|-------------|
| Insulation Classification per DIN VDE 0110/1.89, Table 1 for rated mains voltage $\leq 150V_{rms}$ for rated mains voltage $\leq 300V_{rms}$ for rated mains voltage $\leq 600V_{rms}$ for rated mains voltage $\leq 1000V_{rms}$ | | I – IV I – IV I – IV I – III | |
| Climatic Classification | | 40/105/21 | |
| Pollution Degree (DIN VDE 0110/1.89) | | 2 | |
| Maximum Working Insulation Voltage | V_{IORM} | 1230 | V_{PEAK} |
| Input to Output Test Voltage, Method b $V_{IORM} \times 1.875 = V_{PR}$, 100% Production Test with $t_m = 1sec$, Partial discharge $< 5 pC$ | V_{PR} | 2306 | V_{PEAK} |
| Input to Output Test Voltage, Method a $V_{IORM} \times 1.6 = V_{PR}$, Type and Sample Test, $t_m = 10 sec$, Partial Discharge $< 5 pC$ | V_{PR} | 1968 | V_{PEAK} |
| Highest Allowable Overvoltage (Transient Overvoltage $t_{ini} = 60 sec$) | V_{IOTM} | 8000 | V_{PEAK} |
| Safety-limiting values – maximum values allowed in the event of a failure | | | |
| Case Temperature | T_S | 175 | $^{\circ}C$ |
| Input Power | $P_{S,INPUT}$ | 400 | mW |
| Output Power | $P_{S,OUTPUT}$ | 1200 | mW |
| Insulation Resistance at $T_S, V_{IO} = 500V$ | R_S | $> 10^9$ | Ohm |

Notes:
Isolation characteristics are guaranteed only within the safety maximum ratings which must be ensured by protective circuits in application. Surface mount classification is class A in accordance with CECCO0802.
Refer to IEC/EN/DIN EN 60747-5-5 Optoisolator Safety Standard section of the Avago Regulatory Guide to Isolation Circuits, AV02-2041EN for a detailed description of Method a and Method b partial discharge test profiles.

Insulation and Safety Related Specifications

| Parameter | Symbol | Value | Units | Conditions |
|---|--------|-------|-------|--|
| Minimum External Air Gap (Clearance) | L(101) | 8.3 | mm | Measured from input terminals to output terminals, shortest distance through air. |
| Minimum External Tracking (Creepage) | L(102) | 8.3 | mm | Measured from input terminals to output terminals, shortest distance path along body. |
| Minimum Internal Plastic Gap (Internal Clearance) | | 0.5 | mm | Through insulation distance conductor to conductor, usually the straight line distance thickness between the emitter and detector. |
| Tracking Resistance (Comparative Tracking Index) | CTI | >175 | V | DIN IEC 112/VDE 0303 Part 1 |
| Isolation Group | | IIIa | | Material Group (DIN VDE 0110) |

Absolute Maximum Ratings

Unless otherwise specified, all voltages at input IC reference to V_{EE1} , all voltages at output IC reference to V_{EE2} .

| Parameter | Symbol | Min. | Max. | Units | Note |
|--|-----------------------|-------------|---------------|-------|------|
| Storage Temperature | T_S | -55 | 125 | °C | |
| Operating Temperature | T_A | -40 | 105 | °C | |
| IC Junction Temperature | T_J | | 125 | °C | 1 |
| Average Input Current | $I_{F(AVG)}$ | | 20 | mA | |
| Peak Transient Input Current (<1 us pulse width, 300pps) | $I_{F(TRAN)}$ | | 1 | A | |
| Reverse Input Voltage | V_R | | 6 | V | |
| /Fault Output Current (Sinking) | $I_{/FAULT}$ | | 10 | mA | |
| /Fault Pin Voltage | $V_{/FAULT}$ | -0.5 | 6 | V | |
| /UVLO Output Current (Sinking) | $I_{/UVLO}$ | | 10 | mA | |
| /UVLO Pin Voltage | $V_{/UVLO}$ | -0.5 | 6 | V | |
| Positive Input Supply Voltage | V_{CC1} | -0.5 | 26 | V | |
| Total Output Supply Voltage | V_{CC2} | -0.5 | 30 | V | |
| Negative Output Supply Voltage | $V_{EE2} - V_E$ | -10 | 0.5 | V | 2 |
| Positive Output Supply Voltage | $V_{CC2} - V_E$ | -0.5 | 30 | V | |
| Gate Drive Output Voltage | $V_{O(peak)}$ | -0.5 | $V_{CC2}+0.5$ | V | |
| Peak Output Current | $ I_{O(peak)} $ | | 2.5 | A | 3 |
| Peak Clamping Sinking Current | I_{CLAMP} | | 2 | A | 3 |
| Miller Clamping Pin Voltage | $V_{CLAMP} - V_{EE2}$ | -0.5 | $V_{CC2}+0.5$ | V | |
| Desat Voltage | $V_{DESAT} - V_E$ | $V_E - 0.5$ | $V_{CC2}+0.5$ | V | 4 |
| Desat Discharging Current (Continuous) | I_{DSCHG} | | 5 | mA | |
| Output IC Power Dissipation | P_O | | 580 | mW | 1 |
| Input IC Power Dissipation | P_I | | 150 | mW | |

Recommended Operating Conditions

| Parameter | Symbol | Min. | Max. | Units | Notes |
|--------------------------------|---------------------|------|------|-------|-------|
| Operating Temperature | T_A | -40 | 105 | °C | |
| Input Supply Voltage | $V_{CC1} - V_{EE1}$ | 8 | 18 | V | |
| Total Output Supply Voltage | $V_{CC2} - V_{EE2}$ | 12 | 20 | V | 5 |
| Negative Output Supply Voltage | $V_{EE2} - V_E$ | -8 | 0 | V | 3 |
| Positive Output Supply Voltage | $V_{CC2} - V_E$ | 12 | 20 | V | |
| Input LED Current | $I_{F(ON)}$ | 10 | 16 | mA | |
| Input Voltage (OFF) | $V_{F(OFF)}$ | -5.5 | 0.8 | V | |
| Input pulse width | $t_{ON(LED)}$ | 500 | | ns | |

Electrical and Switching Specifications

Unless otherwise specified, all Minimum/Maximum specifications are at recommended operating conditions. All typical values at $T_A = 25^\circ\text{C}$, $V_{CC1} = 12\text{V}$, $V_{CC2} - V_{EE2} = 13\text{V}$, $V_E - V_{EE2} = 0\text{V}$. All voltages at input IC reference to V_{EE1} , all voltages at output IC reference to V_{EE2} .

| Parameter | Symbol | Min. | Typ.* | Max. | Units | Test Conditions | Fig. | Note |
|--|----------------|-----------------|-----------------|-------|---------------|-------------------------------|------|-------|
| IC Supply Current | | | | | | | | |
| Input Supply Current | I_{CCI} | | 3.7 | 6.0 | mA | | 3 | |
| Output Low Supply Current | I_{CC2L} | | 10.5 | 13.2 | mA | $I_F = 0\text{mA}$ | 4 | |
| Output High Supply Current | I_{CC2H} | | 10.6 | 13.6 | mA | $I_F = 10\text{mA}$ | 4 | |
| Logic Input and Output | | | | | | | | |
| LED Forward Voltage | V_F | 1.25 | 1.55 | 1.85 | V | $I_F = 10\text{mA}$ | 5 | |
| LED Reverse Breakdown Voltage | V_{BR} | 6 | | | V | $I_F = -10\mu\text{A}$ | | |
| Input Capacitance | C_{IN} | | 90 | | pF | | | |
| LED Turn on Current Threshold Low to High | I_{TH+} | | 2.7 | 6.6 | mA | $V_O = 5\text{V}$ | 6 | |
| LED Turn on Current Threshold High to Low | I_{TH-} | | 2.1 | 6.4 | mA | $V_O = 5\text{V}$ | 6 | |
| LED Turn on Current Hysteresis | I_{TH_HYS} | | 0.6 | | mA | | | |
| /FAULT Logic Low Output Current | I_{FAULT_L} | 4.0 | 9.0 | | mA | $V_{/FAULT} = 0.4\text{V}$ | | |
| /FAULT Logic High Output Current | I_{FAULT_H} | | | 20 | μA | $V_{/FAULT} = 5\text{V}$ | | |
| /UVLO Logic Low Output Current | I_{UVLO_L} | 4.0 | 9.0 | | mA | $V_{/UVLO} = 0.4\text{V}$ | | |
| /UVLO Logic High Output Current | I_{UVLO_H} | | | 20 | μA | $V_{/UVLO} = 5\text{V}$ | | |
| Gate Driver | | | | | | | | |
| High Level Output Current | I_{OH} | | -2.0 | -0.75 | A | $V_O = V_{CC2} - 3\text{V}$ | 7 | 4 |
| Low Level Output Current | I_{OL} | 1.0 | 2.2 | | A | $V_O = V_{EE2} + 2.5\text{V}$ | 8 | 4 |
| High Level Output Voltage | V_{OH} | $V_{CC2} - 0.5$ | $V_{CC2} - 0.2$ | | V | $I_O = -100\text{mA}$ | | 6 - 8 |
| Low Level Output Voltage | V_{OL} | | 0.1 | 0.5 | V | $I_O = 100\text{mA}$ | | |

| Parameter | Symbol | Min. | Typ.* | Max. | Units | Test Conditions | Fig. | Note |
|--|-----------------------|------|-------|------|-------------|---|-------|-------|
| VIN to High Level Output Propagation Delay Time | t_{PLH} | 50 | 110 | 250 | ns | Vsource = 3.3V Rf = 140 Ω , Rg = 10 Ω Load = 1 nF f = 200 kHz Duty Cycle = 50% | 9, 12 | 9 |
| VIN to Low Level Output Propagation Delay Time | t_{PHL} | 50 | 150 | 250 | ns | | 10 | |
| Pulse Width Distortion ($t_{PHL}-t_{PLH}$) | PWD | -20 | | 100 | ns | | 11,12 | |
| Dead Time Distortion ($t_{PLH}-t_{PHL}$) | DTD | -100 | | 20 | ns | | 12,13 | |
| 10% to 90% Rise Time | t_R | | 60 | | ns | | | |
| 90% to 10% Fall Time | t_F | | 50 | | ns | | | |
| Output High Level Common Mode Transient Immunity | CM_H | 50 | >70 | | kV/ μ s | $T_A=25^\circ C$, $V_{CM}=1500V$, $V_{CC2}=20V$ | 13 | 14 |
| Output Low Level Common Mode Transient Immunity | CM_L | 50 | >70 | | kV/ μ s | $T_A=25^\circ C$, $V_{CM}=1500V$, $V_{CC2}=20V$ | 14 | 15 |
| Active Miller Clamp | | | | | | | | |
| Clamp Threshold Voltage | V_{TH_CLAMP} | | 2.0 | 3.0 | V | | | |
| Clamp Low Level Sinking Current | I_{CLAMP} | 0.75 | 1.9 | | A | $V_{CLAMP} = V_{EE2} + 2.5 V$ | | |
| V_{CC2} UVLO Protection (UVLO voltage V_{UVLO} reference to V_E) | | | | | | | | |
| V_{CC2} UVLO Threshold Low to High | V_{UVLO+} | 8.8 | 10 | 11.2 | V | $V_O > 5 V$ | | 8, 16 |
| V_{CC2} UVLO Threshold High to Low | V_{UVLO-} | 7.8 | 9 | 10.2 | V | $V_O < 5 V$ | | 8, 17 |
| V_{CC2} UVLO Hysteresis | V_{UVLO_HYS} | | 1 | | V | | | |
| V_{CC2} to UVLO High Delay | t_{PLH_UVLO} | | 10 | | μ s | | | 18 |
| V_{CC2} to UVLO Low Delay | t_{PHL_UVLO} | | 10 | | μ s | | | 19 |
| V_{CC2} UVLO to V_{OUT} High Delay | t_{UVLO_ON} | | 10 | | μ s | | | 20 |
| V_{CC2} UVLO to V_{OUT} Low Delay | t_{UVLO_OFF} | | 10 | | μ s | | | 21 |
| V_{CC2} UVLO Threshold Low to High | V_{UVLO+} | 8.8 | 10 | 11.2 | V | $V_O > 5 V$ | | 8, 16 |
| Desaturation Protection (Desat voltage V_{DESAT} reference to V_E) | | | | | | | | |
| Desat Sensing Threshold | V_{DESAT} | 3.4 | 3.9 | 4.4 | V | | 10 | 8 |
| Desat Discharging Current (Pulsed) | I_{DSCHG} | 20 | 53 | | mA | $V_{DESAT} = 5V$ | 11 | |
| Internal Desat Blanking Time | $t_{DESAT(BLANKING)}$ | 0.2 | 0.4 | 0.6 | μ s | Load = 1 nF | 6 | 22 |
| Desat Sense to 90% VO Delay | $t_{DESAT(90\%)}$ | | 0.15 | 0.5 | μ s | | 6 | 23 |
| Desat to Low Level FAULT Signal Delay | $t_{DESAT(/FAULT)}$ | | | 7 | μ s | | 6 | 24 |
| Output Mute Time due to Desat | $t_{DESAT(MUTE)}$ | 2.3 | 3.2 | 5 | ms | | 6 | 25 |
| Time for Input Kept Low Before Fault Reset to High | $t_{DESAT(RESET)}$ | 2.3 | 3.2 | 5 | ms | | 6 | 26 |

Package Characteristics

| Parameter | Symbol | Min. | Typ. | Max. | Units | Test Conditions | Note |
|--|-----------|------|-----------|------|--------------------|---|------------|
| Input-Output Momentary Withstand Voltage | V_{ISO} | 5000 | | | V_{RMS} | RH < 50%, t = 1 min. $T_A = 25^\circ\text{C}$ | 27, 28, 29 |
| Resistance (Input-Output) | R_{I-O} | | 10^{14} | | Ω | $V_{I-O} = 500 V_{DC}$ | 29 |
| Capacitance (Input-Output) | C_{I-O} | | 1.3 | | pF | f = 1 MHz | |
| Thermal coefficient between LED and input IC | A_{EI} | | 35.4 | | $^\circ\text{C/W}$ | | |
| Thermal coefficient between LED and output IC | A_{EO} | | 33.1 | | $^\circ\text{C/W}$ | | |
| Thermal coefficient between input IC and output IC | A_{IO} | | 25.6 | | $^\circ\text{C/W}$ | | |
| Thermal coefficient between LED and Ambient | A_{EA} | | 176.1 | | $^\circ\text{C/W}$ | | |
| Thermal coefficient between input IC and Ambient | A_{IA} | | 92 | | $^\circ\text{C/W}$ | | |
| Thermal coefficient between output IC and Ambient | A_{OA} | | 76.7 | | $^\circ\text{C/W}$ | | |

Notes:

- Output IC power dissipation is derated linearly above 95°C from 580 mW to 380 mW at 105°C based on the thermal characteristic on page 11.
- This supply is optional. Required only when negative gate drive is implemented.
- Maximum pulse width = 1 μs , maximum duty cycle = 1%.
- Maximum 500 ns pulse width if peak $V_{DESAT} > 10\text{ V}$.
- 12 V is the recommended minimum operating positive supply voltage ($V_{CC2} - V_E$) to ensure adequate margin in excess of the maximum V_{UVLO+} threshold of 11.2 V.
- For High Level Output Voltage testing, V_{OH} is measured with a DC load current. When driving capacitive loads, V_{OH} will approach V_{CC} as I_{OH} approaches zero.
- Maximum pulse width = 1.0 ms, maximum duty cycle = 20%.
- Once V_O of the ACPL-335J is allowed to go high ($V_{CC2} - V_E > V_{UVLO}$), the DESAT detection feature of the ACPL-335J will be the primary source of IGBT protection. UVLO is needed to ensure DESAT is functional. Once V_{CC2} exceeds V_{UVLO+} threshold, DESAT will remain functional until V_{CC2} is below V_{UVLO-} threshold. Thus, the DESAT detection and UVLO features of the ACPL-335J work in conjunction to ensure constant IGBT protection.
- t_{PLH} is defined as propagation delay from 50% of LED input I_F to 50% of High level output.
- t_{PHL} is defined as propagation delay from 50% of LED input I_F to 50% of Low level output.
- Pulse Width Distortion (PWD) is defined as ($t_{PHL} - t_{PLH}$) of any given unit.
- As measured from I_F to V_O .
- Dead Time Distortion (DTD) is defined as ($t_{PLH} - t_{PHL}$) between any two ACPL-335J parts under the same test conditions.
- Common mode transient immunity in the high state is the maximum tolerable dV_{CM}/dt of the common mode pulse, V_{CM} , to assure that the output will remain in the high state (i.e., $V_O > 12\text{ V}$).
- Common mode transient immunity in the low state is the maximum tolerable dV_{CM}/dt of the common mode pulse, V_{CM} , to assure that the output will remain in a low state (i.e., $V_O < 1.0\text{ V}$).
- This is the "increasing" (i.e., turn-on or "positive going" direction) of $V_{CC2} - V_E$.
- This is the "decreasing" (i.e., turn-off or "negative going" direction) of $V_{CC2} - V_E$.
- The delay time when V_{CC2} exceeds UVLO+ threshold to UVLO High – 50% of UVLO positive-going edge.
- The delay time when V_{CC2} falls below UVLO- threshold to UVLO Low – 50% of UVLO negative-going edge.
- The delay time when V_{CC2} exceeds UVLO+ threshold to 50% of High level output.
- The delay time when V_{CC2} falls below UVLO- threshold to 50% of Low level output.
- The delay time for ACPL-335J to respond to a DESAT fault condition without any external DESAT capacitor.
- The amount of time from when DESAT threshold is exceeded to 90% of VGATE at mentioned test conditions.
- The amount of time from when DESAT threshold is exceeded to FAULT output Low – 50% of V_{CC1} voltage.
- The amount of time when DESAT threshold is exceeded, Output is mute to LED input.
- The amount of time when DESAT Mute time is expired, LED input must be kept Low for Fault status to return to High.
- In accordance with UL1577, each optocoupler is proof tested by applying an insulation test voltage $\geq 6000 V_{RMS}$ for 1 second.
- The Input-Output Momentary Withstand Voltage is a dielectric voltage rating that should not be interpreted as an input-output continuous voltage rating. For the continuous voltage rating, refer to your equipment level safety specification or IEC/EN/DIN EN 60747-5-5 Insulation Characteristics Table.
- Device considered a two terminal device: pins 1 - 8 shorted together and pins 9 - 16 shorted together.

Thermal Characteristics

Thermal Characteristics are based on the ground planes layout of the evaluation PCB.

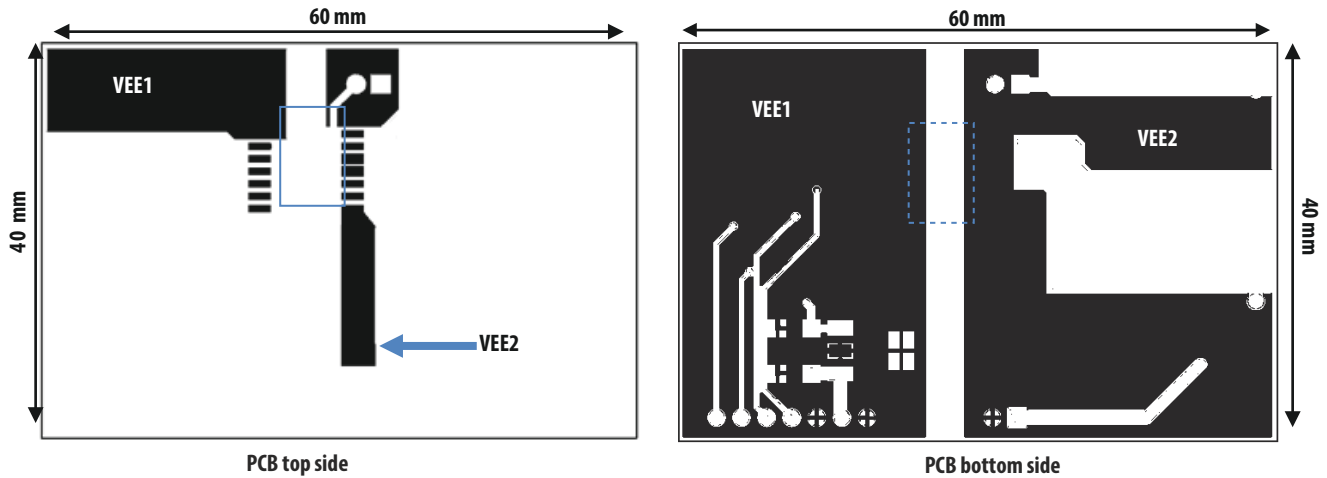

Notes on Thermal Calculation

Application and environmental design for ACPL-335J needs to ensure that the junction temperature of the internal ICs and LED within the gate driver optocoupler do not exceed 125°C. The following equations calculate the maximum power dissipation and corresponding effect on junction temperatures and can only be used as a reference for thermal performance comparison under specified PCB layout as shown above. The thermal resistance model shown here is not meant to and will not predict the performance of a package in an application-specific environment.

$$\begin{aligned} \text{LED Junction Temperature} &= A_{EA} * P_E + A_{EI} * P_I + A_{EO} * P_O + T_A \\ \text{Input IC Junction Temperature} &= A_{EI} * P_E + A_{IA} * P_I + A_{IO} * P_O + T_A \\ \text{Output IC Junction Temperature} &= A_{EO} * P_E + A_{IO} * P_I + A_{OA} * P_O + T_A \end{aligned}$$

P_E - LED Power Dissipation
 P_I - Input IC Power Dissipation
 P_O - Output IC Power Dissipation

Calculation of LED Power Dissipation

LED Power Dissipation, $P_E = I_{F(LED)} (\text{Recommended Max}) * V_{F(LED)} * \text{Duty Cycle}$
 Example: $P_E = 16\text{mA} * 1.25 * 50\% \text{ duty cycle} = 10\text{mW}$

Calculation of Input IC Power Dissipation

Input IC Power Dissipation, $P_I = I_{CC1} (\text{Max}) * V_{CC1} (\text{Recommended Max})$
 Example: $P_I = 6\text{mA} * 18\text{V} = 108\text{mW}$

Calculation of Output IC Power Dissipation

Output IC Power Dissipation, $P_O = V_{CC2}$ (Recommended Max) * I_{CC2} (Max) + P_{HS} + P_{LS}

P_{HS} - High Side Switching Power Dissipation

P_{LS} - Low Side Switching Power Dissipation

$$P_{HS} = (V_{CC2} * Q_G * f_{PWM}) * R_{OH(MAX)} / (R_{OH(MAX)} + R_{GH}) / 2$$

$$P_{LS} = (V_{CC2} * Q_G * f_{PWM}) * R_{OL(MAX)} / (R_{OL(MAX)} + R_{GL}) / 2$$

Q_G - Gate Charge at Supply Voltage

f_{PWM} - LED Switching Frequency

$R_{OH(MAX)}$ - Maximum High Side Output Impedance - $V_{OH(MIN)} / I_{OH(MIN)}$

R_{GH} - Gate Charging Resistance

$R_{OL(MAX)}$ - Maximum Low Side Output Impedance - $V_{OL(MIN)} / I_{OL(MIN)}$

R_{GL} - Gate Discharging Resistance

Example:

$$R_{OH(MAX)} = (V_{CC2} - V_{OH(MIN)}) / I_{OH(MIN)} = 3 \text{ V} / 0.75 \text{ A} = 4 \Omega$$

$$R_{OL(MAX)} = V_{OL(MIN)} / I_{OL(MIN)} = 2.5 \text{ V} / 1 \text{ A} = 2.5 \Omega$$

$$P_{HS} = (20 \text{ V} * 100 \text{ nC} * 200 \text{ kHz}) * 4 \Omega / (4 \Omega + 10 \Omega) / 2 = 57.14 \text{ mW}$$

$$P_{LS} = (20 \text{ V} * 100 \text{ nC} * 200 \text{ kHz}) * 2.5 \Omega / (2.5 \Omega + 10 \Omega) / 2 = 40 \text{ mW}$$

$$P_O = 20 \text{ V} * 13.6 \text{ mA} + 57.14 \text{ mW} + 40 \text{ mW} = 360.14 \text{ mW}$$

Calculation of Junction Temperature

$$\text{LED Junction Temperature} = 176.1 \text{ }^\circ\text{C/W} * 10 \text{ mW} + 35.4 \text{ }^\circ\text{C/W} * 108 \text{ mW} + 33.1 * 360.14 \text{ mW} + T_A = 17.5^\circ\text{C} + T_A$$

$$\text{Input IC Junction Temperature} = 35.4 \text{ }^\circ\text{C/W} * 10 \text{ mW} + 92 \text{ }^\circ\text{C/W} * 108 \text{ mW} + 25.6 * 360.14 \text{ mW} + T_A = 19.5^\circ\text{C} + T_A$$

$$\text{Output IC Junction Temperature} = 33.1 \text{ }^\circ\text{C/W} * 10 \text{ mW} + 25.6 \text{ }^\circ\text{C/W} * 108 \text{ mW} + 76.7 * 360.14 \text{ mW} + T_A = 30.7^\circ\text{C} + T_A$$

Typical Performance Plots

Figure 1 I_{CC1} across temperature

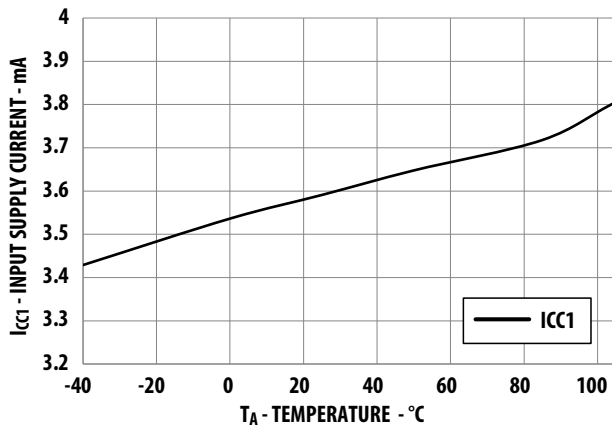

Figure 2 I_{CC2} across temperature

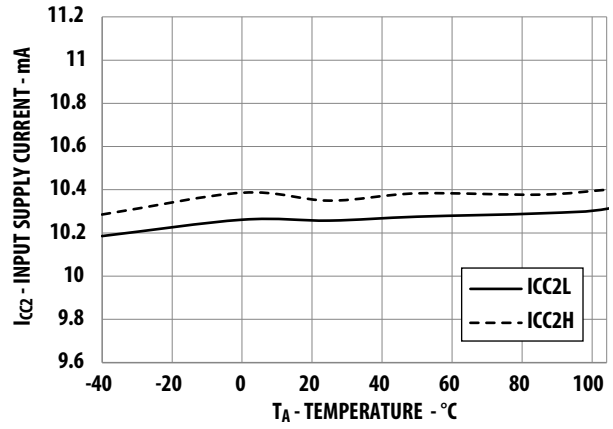

Figure 3 I_F vs V_F

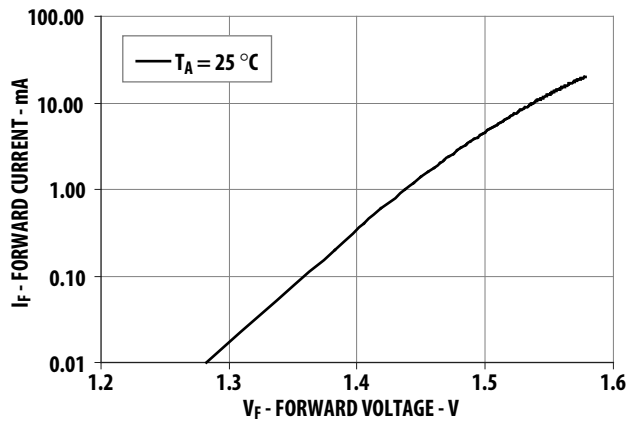

Figure 4 I_{TH} across temperature

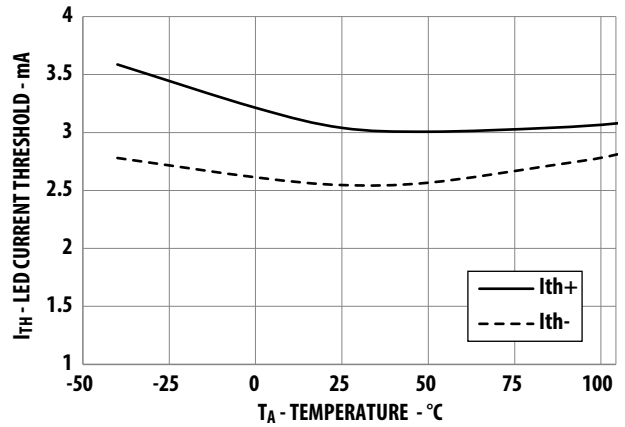

Figure 5 V_{OH} vs I_{OH}

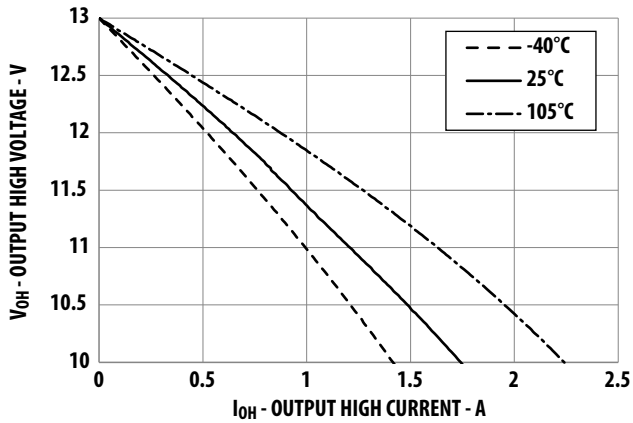

Figure 6 V_{OL} vs I_{OL}

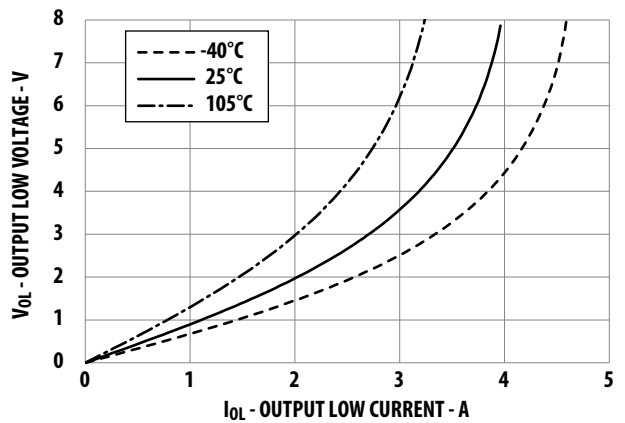

Figure 7 T_p across temperature

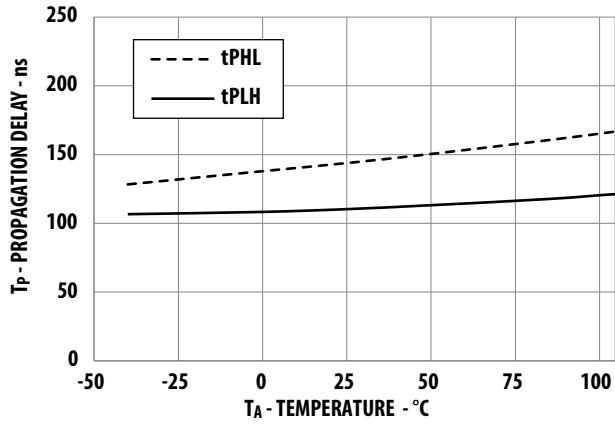

Figure 8 V_{DESAT} Threshold across temperature

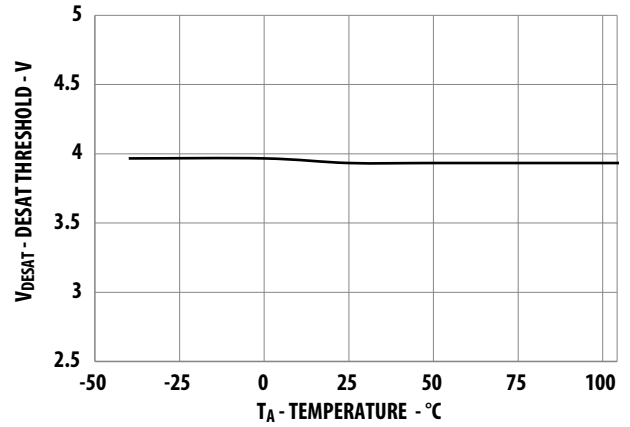

Figure 9 I_{DSCHG} across temperature

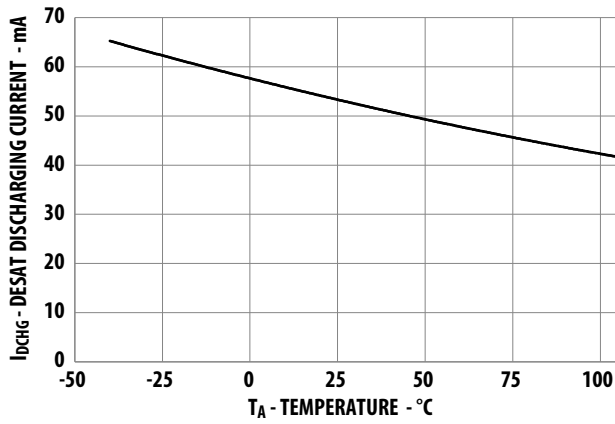

Figure 10 Propagation Delay Test Circuit and Timing Diagram

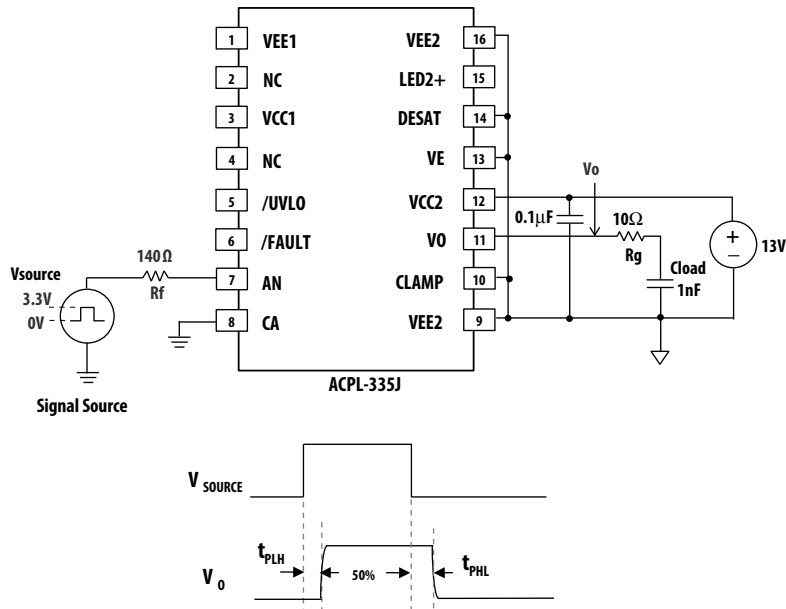

Figure 11 CMR Vo High Test Circuit

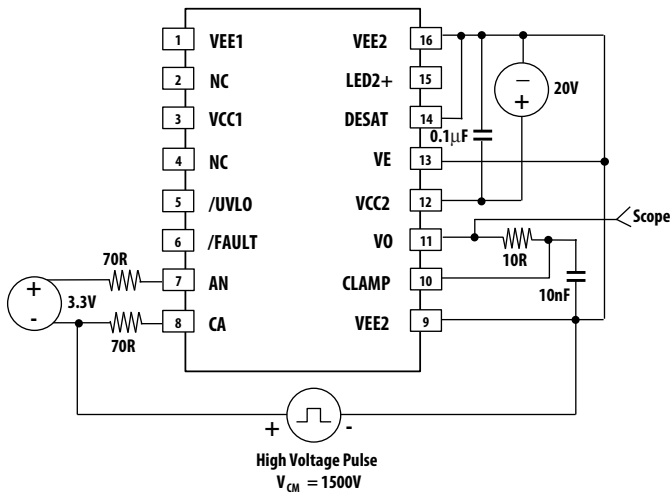

Figure 12 CMR Vo Low Test Circuit

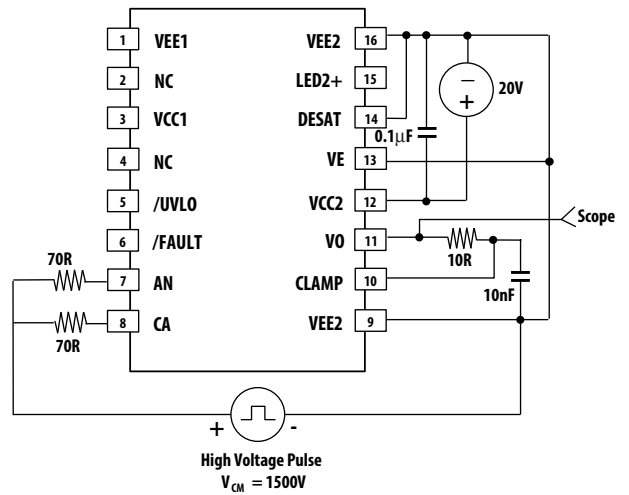
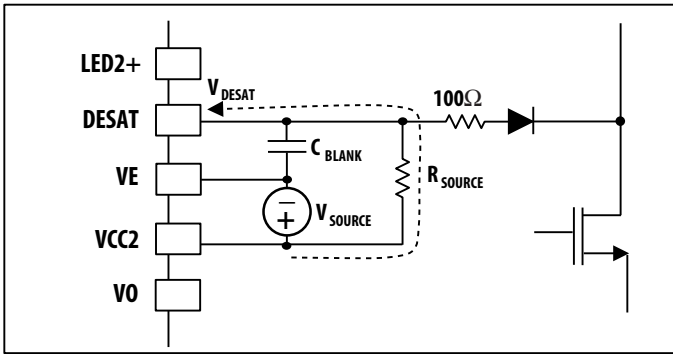

Figure 14 External RC charging circuit



Description of Gate Driver and Miller Clamping

The gate driver is directly controlled by the LED current. When LED current is driven high the output of ACPL-335J is capable of delivering 2.5A sourcing current to drive the MOSFET's gate. While LED is switched off the gate driver can provide 2.5A sinking current to switch the gate off fast. Additional miller clamping pull-down transistor is activated when output voltage reaches about 2V with respect to V_{EE2} to provide low impedance path to miller current as shown in Figure 15.

Figure 15 Gate drive signal behavior

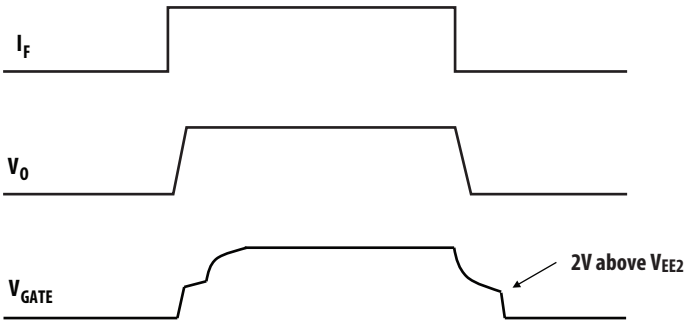
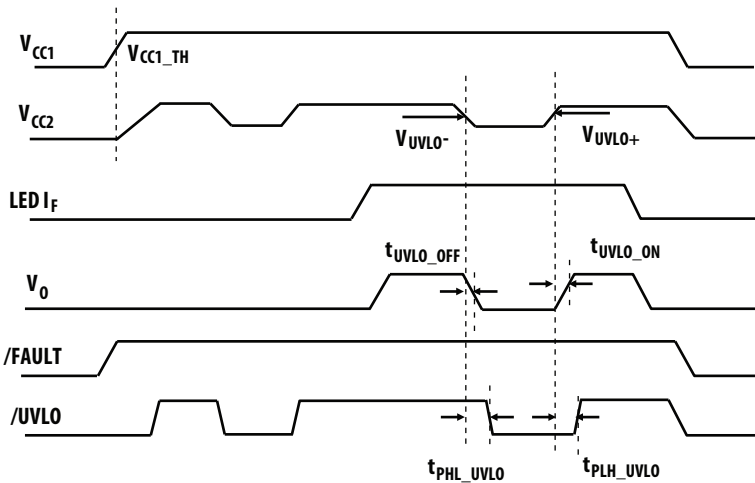

Figure 16 Circuit behaviors at power up and power down



Description of Under Voltage Lock Out

Insufficient gate voltage to MOSFET can increase turn on resistance of MOSFET, resulting in large power loss and MOSFET damage due to high heat dissipation. ACPL-335J monitors the output power supply constantly. When output power supply is lower than under voltage lockout (UVLO) threshold gate driver output will shut off to protect MOSFET from low voltage bias. During power up, the UVLO feature forces the gate driver output to low to prevent unwanted turn-on at lower voltage.

Description of Operation during Over Current Condition

1. DESAT terminal monitors MOSFET's Drain-Source voltage, V_{DS} .
2. When the voltage on the DESAT terminal exceeds Desat sensing threshold, the output shuts down immediately.
3. FAULT output goes low, notifying the microcontroller of the fault condition.
4. Microcontroller takes appropriate action.
5. When $t_{DESAT(MUTE)}$ expires LED input need to be kept low for $t_{DESAT(RESET)}$ before fault condition is cleared. FAULT status will return to high and CLAMP output will return to Hi-Z state.
6. Output (V_O) starts to respond to LED input after fault condition is cleared.

Figure 17 Circuit behaviors during over current event

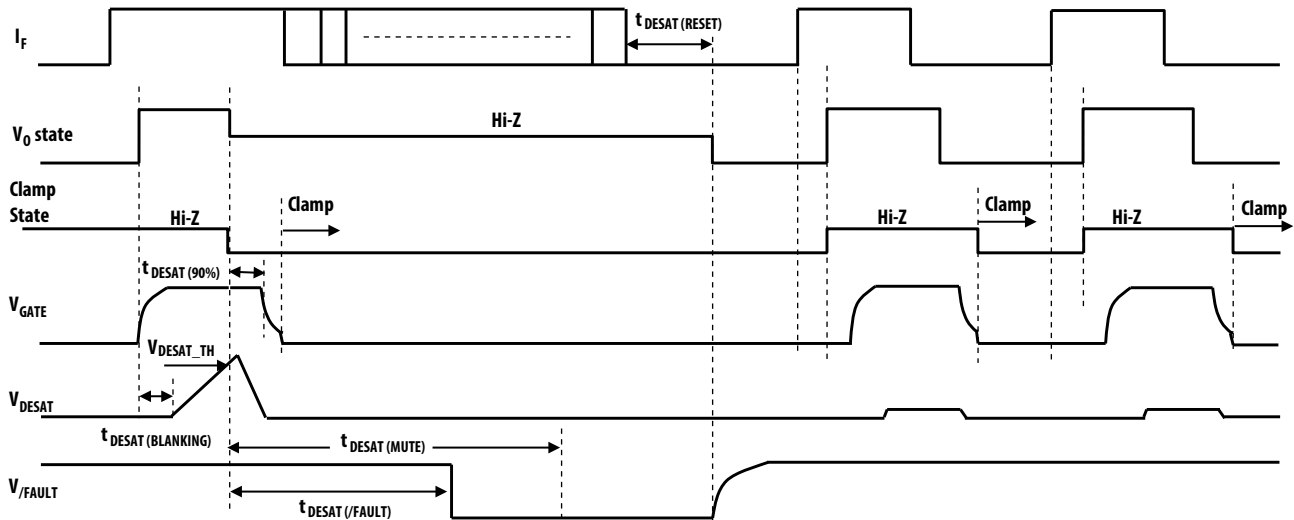

Recommended LED Drive Circuits

There will be common mode noise whenever there is a difference in the ground level of the optocoupler's input control circuitry and that of the output control circuitry. Figure 18 and Figure 19 show the recommended LED drive circuits that use logic gate (CMOS buffer) for high common mode rejection (CMR) performance of the optocoupler gate driver. Split limiting resistors are used to balance the impedance at both anode and cathode of the input LED for high common mode noise rejection. The output impedance of the CMOS buffer (shown as R_O in Figure 18 and Figure 19) has to be included in the calculation for LED drive current.

On the other hand, Figure 20 shows the recommended LED drive circuits that use a single transistor. During the LED off state, M1 and Q1 in Figure 20 will shunt current, which results in greater power consumption. It is not recommended to have open drain and open collector drive circuits, as shown in Figure 21. This is because during the off state of the MOSFET/transistor, the cathode of the input LED sees high impedance and becomes sensitive to common mode switching noise.

Figure 18 Recommended non inverting drive circuit

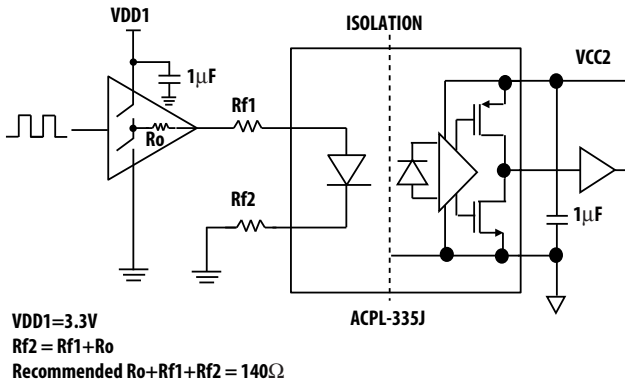

Figure 19 Recommended single transistor drive circuit

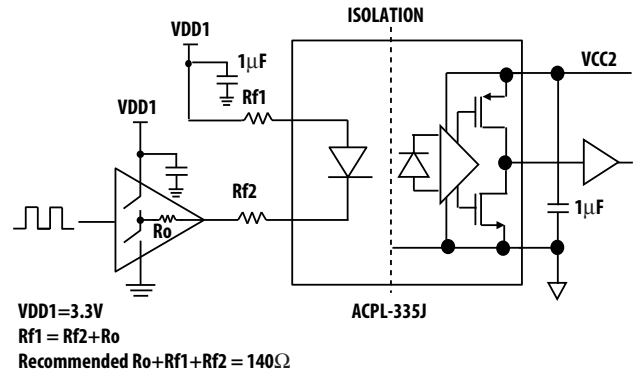

Figure 20 Recommended inverting drive circuit

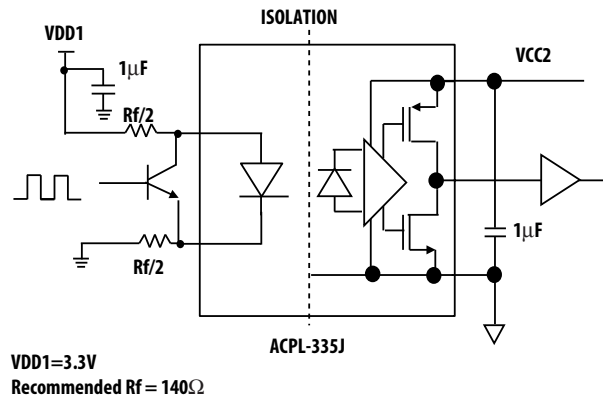
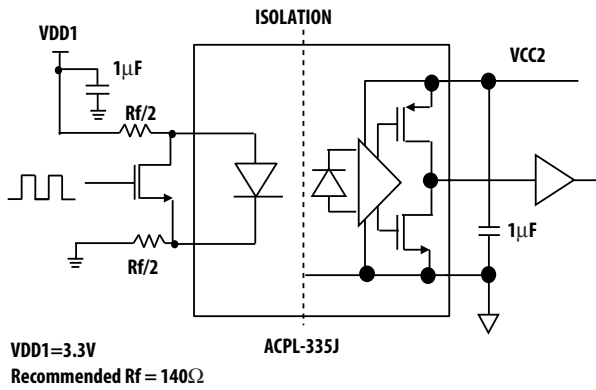
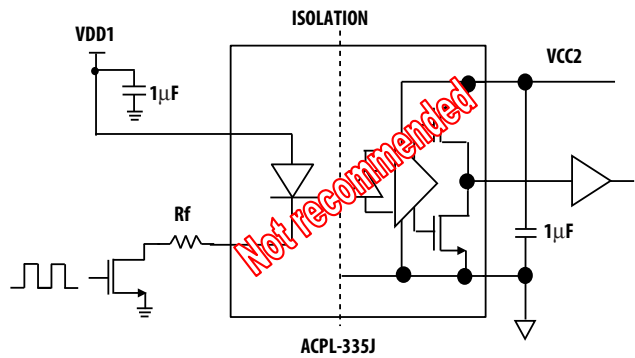
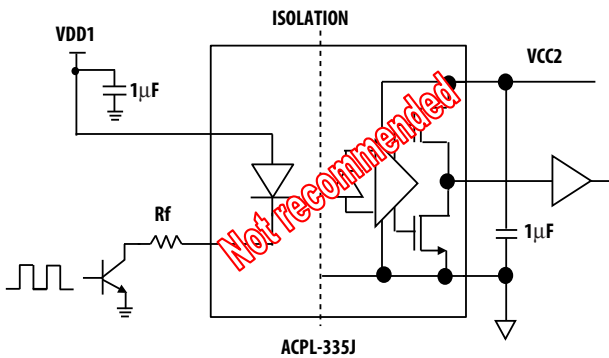

Figure 21 Not recommended – Open drain/ open collector drive circuit



Drive Power

If a CMOS buffer is used to drive the LED, it is recommended that user connect the CMOS buffer at the LED cathode. This is because the sinking capability of the NMOS is usually greater than the driving capability of the PMOS in a CMOS buffer.

Drive Logic

The designer can configure LED drive circuits for non-inverting and inverting logic as recommended in Figure 21 and Figure 22. For the inverting and non-inverting logic to work, the external power supply V_{DD1} must be connected to the CMOS buffer. If the V_{DD1} supply is lost, the LED will be permanently off and output will be low.

Bypass and Reservoir Capacitors

Supply bypass capacitors are necessary at the input buffer and ACPL-335J output supply pins. A ceramic capacitor with the value of $1\ \mu\text{F}$ is recommended at the input buffer to provide high frequency bypass, which also helps to improve CMR performance. At the output supply pins, it is recommended to use a $1\ \mu\text{F}$ low ESR and low ESL capacitor across $V_{CC2} - V_E$, $V_E - V_{EE2}$ and $V_{CC2} - V_{EE2}$ pins. These capacitors are used to supply instant driving current to MOSFET at V_{OUT} during switching.

Anti-Cross Conduction Drive

One of the many benefits of using ACPL-335J is the ease of implementing anti-cross conduction drive between the high side and the low side gate drivers to prevent a shoot-through event. This safety interlock drive can be realized by interlocking the output of buffer U3 and U4 to both the high and the low side gate drivers, as shown in Figure 22. Due to the difference in propagation delay between optocouplers, however, a certain amount of dead time has to be added to ensure sufficient dead time at the MOSFET gate. For more details, see the "Dead Time and Propagation Delay" section.

Figure 22 Typical high speed MOSFET gate drive circuit

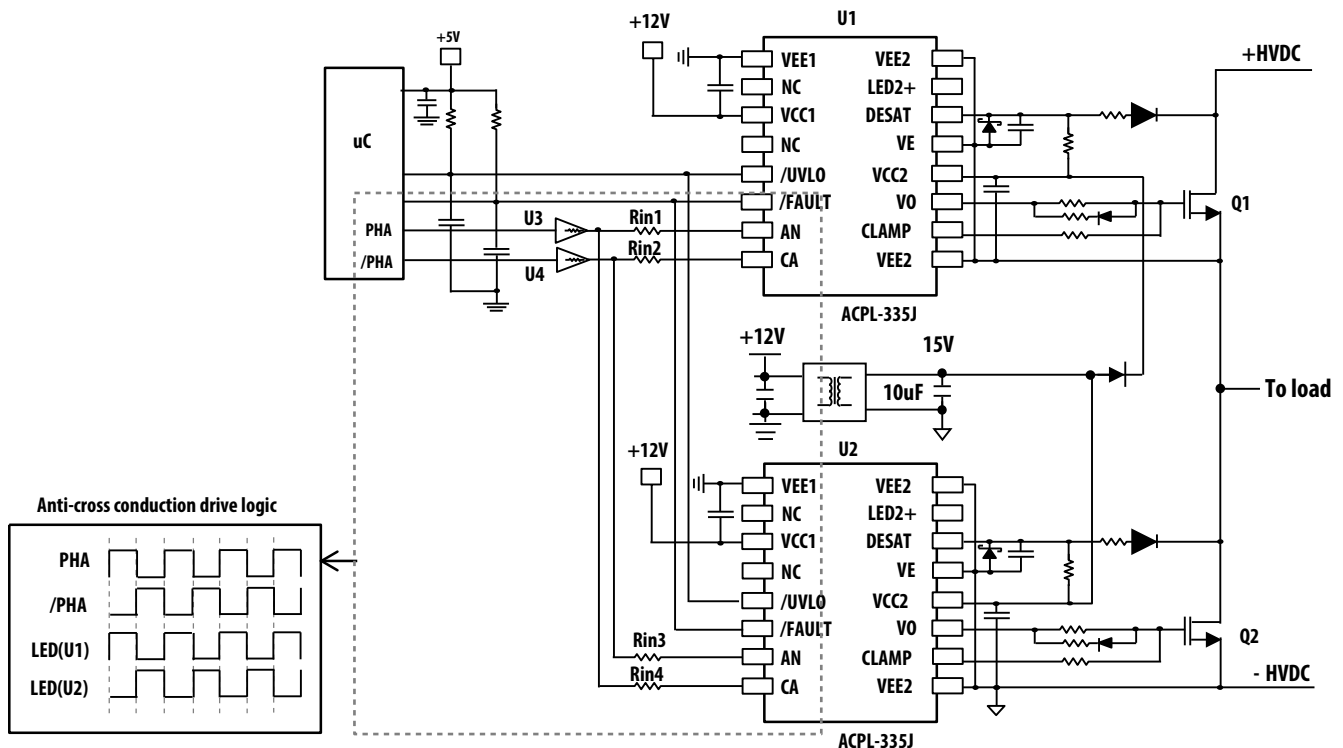

Dead Time Distortion and Propagation Delay

Dead time is the period of time during which both high side and low side power transistors (shown as Q1 and Q2 in Figure 22) are off. Originally, the system is required to design in some amount of dead time to compensate for the turnoff delay needed for the MOSFET to discharge the input capacitance after the gate is switched off. In this application note, this amount of dead time is called system original dead time. When an optocoupler is used, the designer has to consider the effect of the optocoupler's dead time distortion (DTD) toward system original dead time. The optocoupler's negative DTD decreases system original dead time; on the other hand, the optocoupler's positive DTD increases system original dead time. Therefore, the designer must add extra dead time to system original dead time to compensate for the optocoupler's negative DTD. Figures 23 and 24 illustrate the effect of the optocoupler's DTD to system original dead time.

Dead Time and Propagation Delay Waveforms

Figure 23 Negative DTD reduces original DT

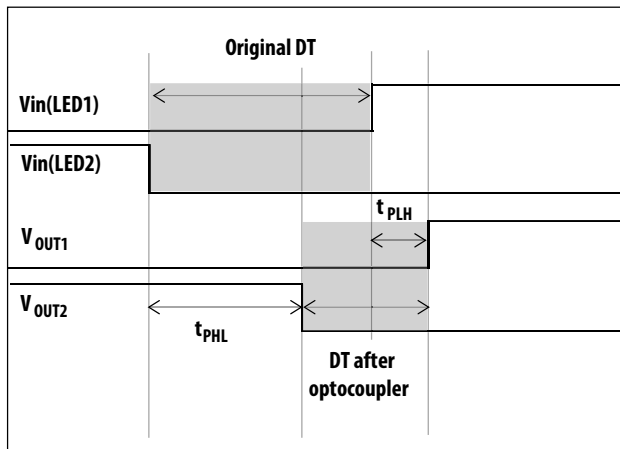
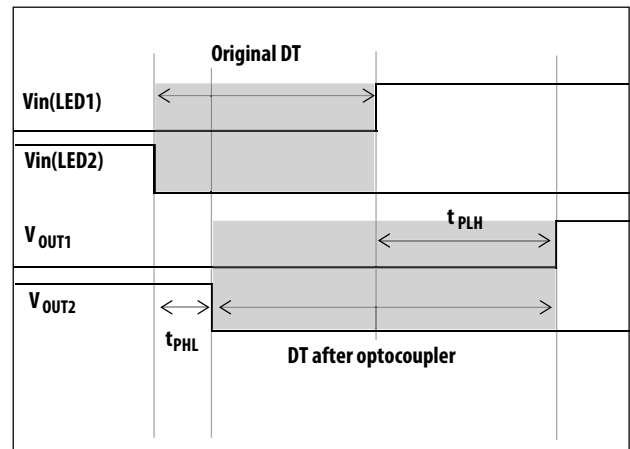

Figure 24 Positive DTD increases original DT



Here is an example of total dead time calculation for a typical optocoupler drive circuit for MOSFET.

Total dead time required

$$= \text{System original dead time} + |\text{optocoupler's negative DTD}|$$

$$= \text{System original dead time} + |100 \text{ ns}|$$

where system original dead time = MOSFET turn-off delay

Note:

The propagation delays used to calculate dead time distortion (DTD) are taken at equal temperatures and test conditions as the optocouplers used under consideration are typically mounted in close proximity to each other and are switching same type of MOSFETs.

For product information and a complete list of distributors, please go to our web site:

www.avagotech.com

Avago Technologies and the A logo are trademarks of Avago Technologies in the United States and other countries. All other brand and product names may be trademarks of their respective companies.

Data subject to change. Copyright © 2015-2016 Avago Technologies. All Rights Reserved.

AV02-4977EN – January 27, 2016





Стандарт Электрон Связь

Мы молодая и активно развивающаяся компания в области поставок электронных компонентов. Мы поставляем электронные компоненты отечественного и импортного производства напрямую от производителей и с крупнейших складов мира.

Благодаря сотрудничеству с мировыми поставщиками мы осуществляем комплексные и плановые поставки широчайшего спектра электронных компонентов.

Собственная эффективная логистика и склад в обеспечивает надежную поставку продукции в точно указанные сроки по всей России.

Мы осуществляем техническую поддержку нашим клиентам и предпродажную проверку качества продукции. На все поставляемые продукты мы предоставляем гарантию .

Осуществляем поставки продукции под контролем ВП МО РФ на предприятия военно-промышленного комплекса России , а также работаем в рамках 275 ФЗ с открытием отдельных счетов в уполномоченном банке. Система менеджмента качества компании соответствует требованиям ГОСТ ISO 9001.

Минимальные сроки поставки, гибкие цены, неограниченный ассортимент и индивидуальный подход к клиентам являются основой для выстраивания долгосрочного и эффективного сотрудничества с предприятиями радиоэлектронной промышленности, предприятиями ВПК и научно-исследовательскими институтами России.

С нами вы становитесь еще успешнее!

Наши контакты:

Телефон: +7 812 627 14 35

Электронная почта: sales@st-electron.ru

Адрес: 198099, Санкт-Петербург,
Промышленная ул, дом № 19, литера Н,
помещение 100-Н Офис 331