

77 GHz Flip-Chip Low Noise Amplifier

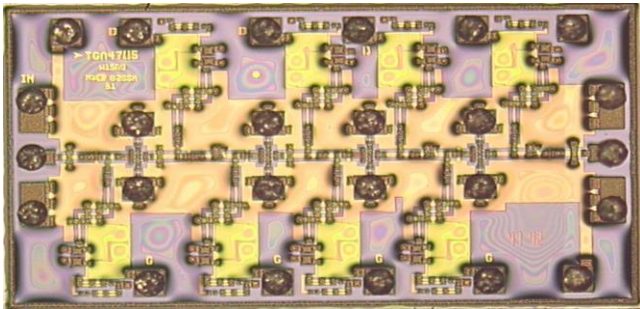

Measured Performance

Bias conditions: $V_d = 2\text{ V}$, $I_d = 60\text{ mA}$

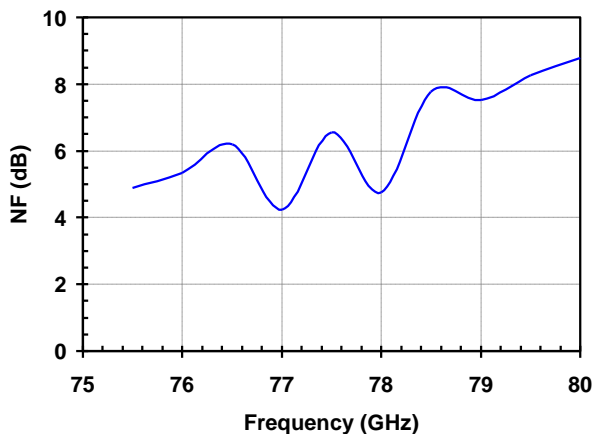

Bias conditions: $V_d = 2.5\text{ V}$, $I_d = 60\text{ mA}$

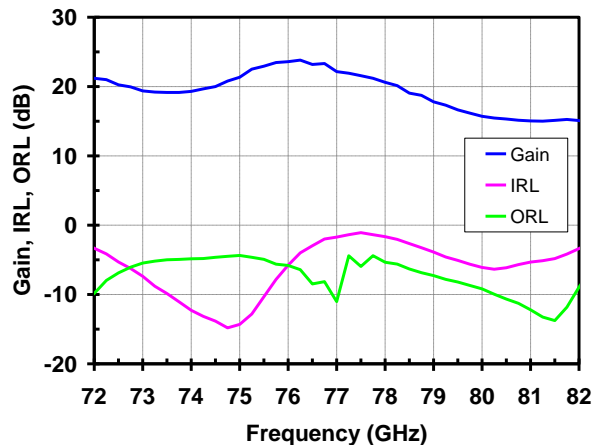

Key Features

- Frequency Range: 72 - 80 GHz
- Noise Figure: 5 dB at 77 GHz
- Gain: 23 dB
- Bias: $V_d = 2.5\text{ V}$, $I_d = 60\text{ mA}$, $V_g = +0.18\text{ V}$ Typical
- Technology: 0.13 μm pHEMT with front-side Cu/Sn pillars
- Chip Dimensions: 2.24 x 1.27 x 0.38 mm

Primary Applications

- Automotive RADAR

Product Description

The TriQuint TGA4705-FC is a flip-chip low noise amplifier designed to operate at frequencies that target the automotive RADAR market. The TGA4705-FC is designed using TriQuint's proven 0.13 μm pHEMT process and front-side Cu / Sn pillar technology for reduced source inductance and superior noise performance at frequencies of 72 – 80 GHz. Die reliability is enhanced by using TriQuint's BCB polymeric passivation process.

The TGA4705-FC is a low noise amplifier that typically provides 23 dB small signal gain with 5 dB noise figure at 77 GHz. The TGA4705-FC is an excellent choice for applications requiring low noise in receive chain architectures.

Lead-free and RoHS compliant.

Table I
Absolute Maximum Ratings 1/

Symbol	Parameter	Value	Notes
Vd-Vg	Drain to Gate Voltage	5.5 V	
Vd	Drain Voltage	4 V	<u>2/</u>
Vg	Gate Voltage Range	-1 to + 0.45 V	
Id	Drain Current	108 mA	<u>2/</u>
Ig	Gate Current Range	-0.24 to +0.25 mA	
Pin	Input Continuous Wave Power	10 dBm	<u>2/</u>
Tchannel	Max Channel Temperature	200 C	

1/ These ratings represent the maximum operable values for this device. Stresses beyond those listed under "Absolute Maximum Ratings" may cause permanent damage to the device and / or affect device lifetime. These are stress ratings only, and functional operation of the device at these conditions is not implied.

2/ Combinations of supply voltage, supply current, input power, and output power shall not exceed the maximum power dissipation listed in Table IV.

Table II
Recommended Operating Conditions

Symbol	Parameter <u>1/</u>	Value
Vd	Drain Voltage	2.5 V
Id	Drain Current	60 mA
Vg	Gate Voltage	+0.18 V Typical

1/ See assembly diagram for bias instructions.

Table III
RF Characterization Table

Bias: Vd = 2.5 V, Id = 60 mA, Vg = 0.18 V, typical

SYMBOL	PARAMETER	TEST CONDITIONS	MIN	NOMINAL	MAX	UNITS
Gain	Small Signal Gain	f = 76 -77 GHz	17	23	26	dB
IRL	Input Return Loss	f = 76 - 77 GHz	3	8	-	dB
ORL	Output Return Loss	f = 76 - 77 GHz	5	10	-	dB
NF	Noise Figure	f = 76 - 77 GHz	-	6	-	dB

Table IV Power Dissipation and Thermal Properties

Parameter	Test Conditions	Value	Notes
Maximum Power Dissipation	Tbaseplate = 102.5 °C	Pd = 0.432 W Tchannel = 150 °C Tm = 2.4E+7 Hrs	<u>1/ 2/ 3/</u>
Thermal Resistance, θ_{jc}	Vd = 2 V Id = 60 mA Pd = 0.12 W Tbaseplate = 85 °C	θ_{jc} = 110 °C/W Tchannel = 98.2 °C Tm = 1.68E+10 Hrs	<u>3/</u>
Mounting Temperature		Refer to Solder Reflow Profiles (pg 11)	
Storage Temperature		-65 to 150 °C	

- 1/ For a median life of 2.4E+7 hours, Power Dissipation is limited to

$$Pd(max) = (150\text{ °C} - Tbase\text{ °C})/\theta_{jc}.$$
- 2/ Channel operating temperature will directly affect the device median lifetime (Tm). For maximum life, it is recommended that channel temperatures be maintained at the lowest possible levels.
- 3/ For this flip-chip die, the baseplate is a plane between the Cu/Sn pillars and the test board. For the TGA4705-FC, the critical pillars for thermal power dissipation are 18 thru 25. (See Mechanical Drawing.)

Median Lifetime (Tm) vs Channel Temperature

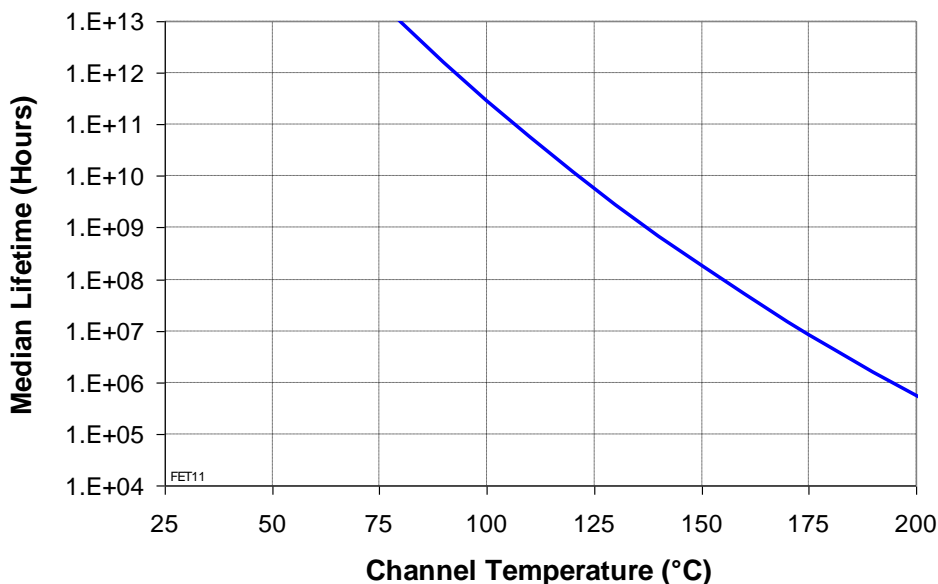

Measured Data on Face-down (flipped) Die on Carrier Board

Bias conditions: $V_d = 2\text{ V}$, $I_d = 60\text{ mA}$

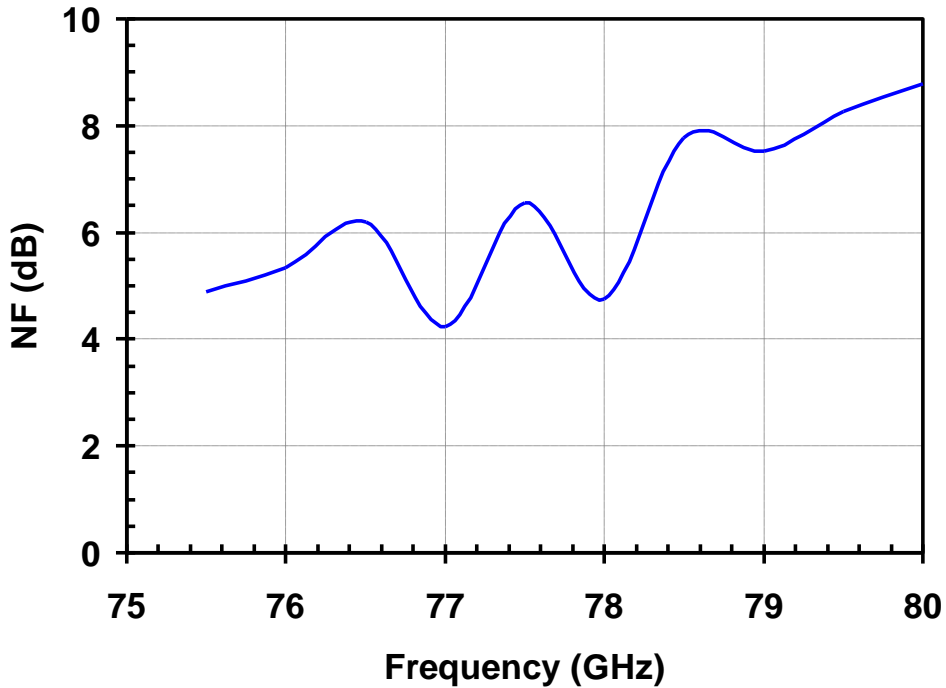

Measured Data on Face-down (flipped) Die on Carrier Board

Bias conditions: $V_d = 2\text{ V}$, $I_d = 60\text{ mA}$

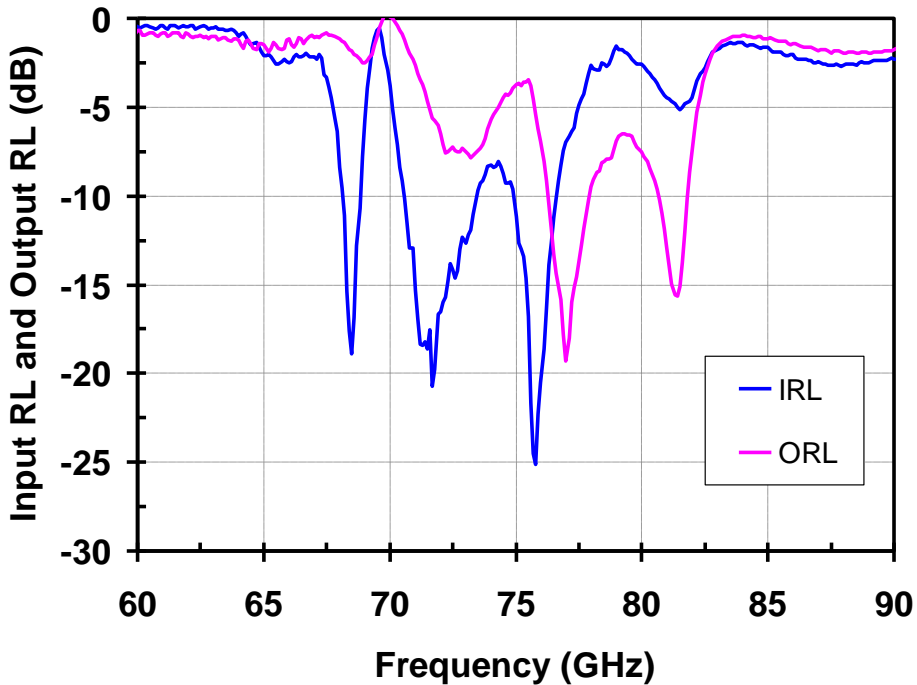
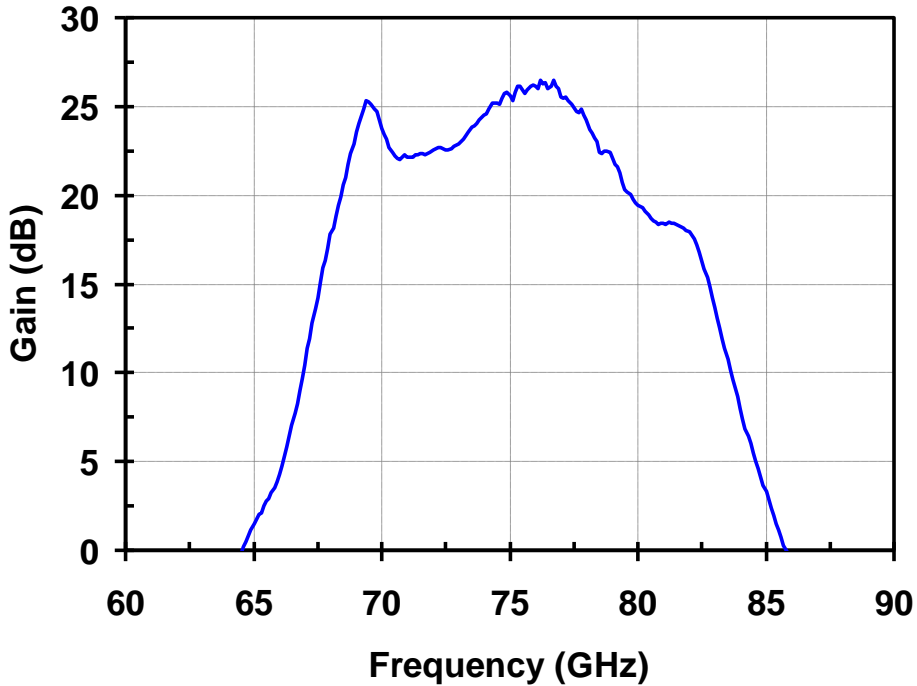

Measured Data on Face-down (flipped) Die on Carrier Board

Bias conditions: $V_d = 2.5\text{ V}$, $I_d = 60\text{ mA}$

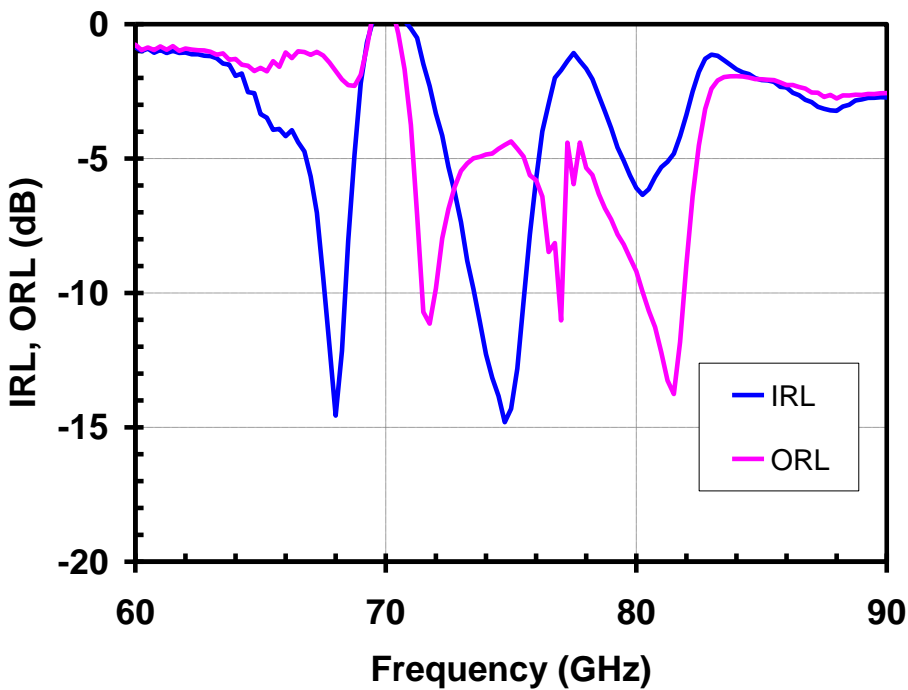
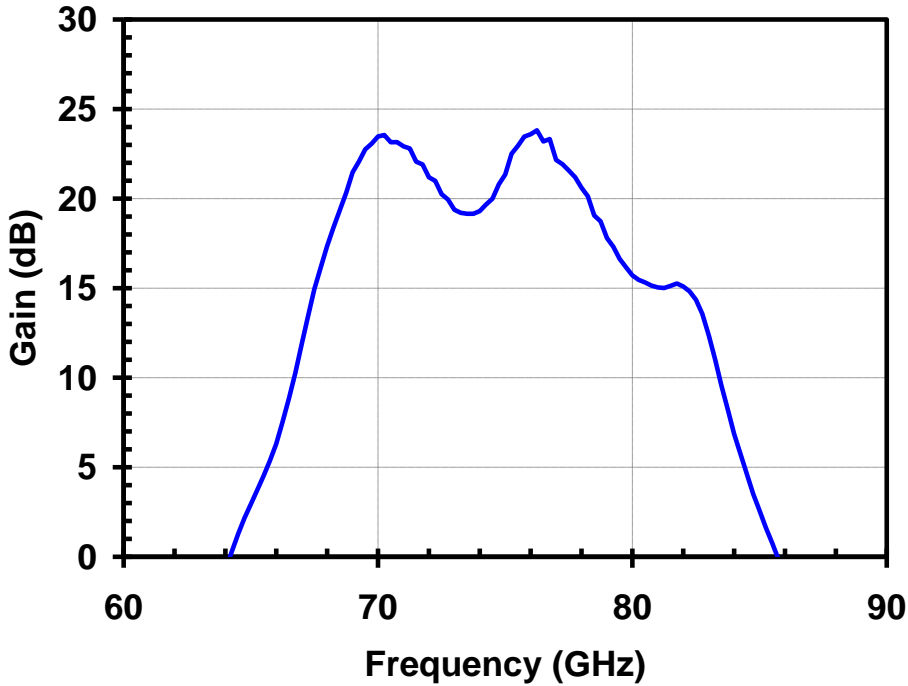

Electrical Schematic

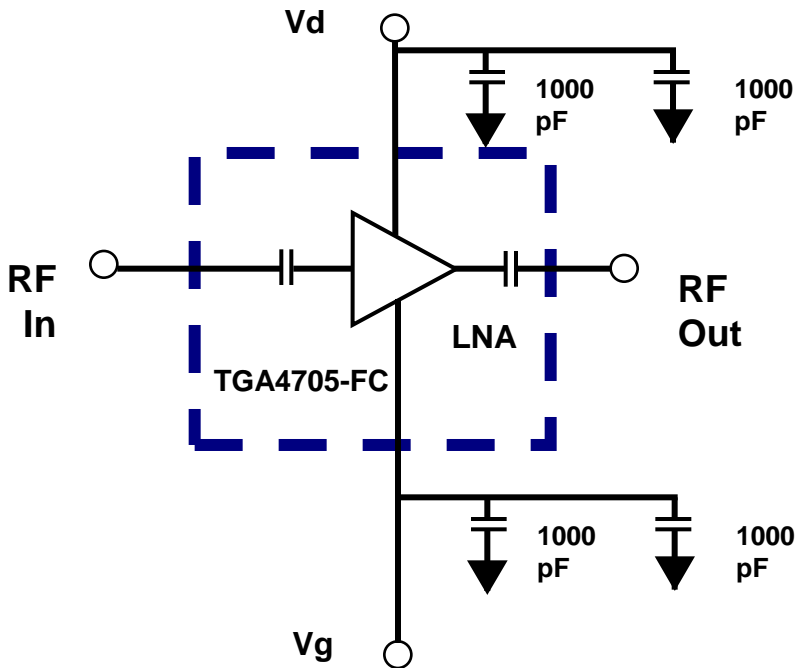

Bias Procedures

Bias-up Procedure

Vg set to -0.5 V

Vd set to +2.5 V

Adjust Vg more positive until Id is 60 mA. This will be Vg ~ +0.18 V

Apply RF signal to input

Bias-down Procedure

Turn off RF supply

Reduce Vg to -0.5V. Ensure Id ~ 0 mA

Turn Vd to 0 V

Turn Vg to 0 V

Mechanical Drawing

Drawing is for chip face-up

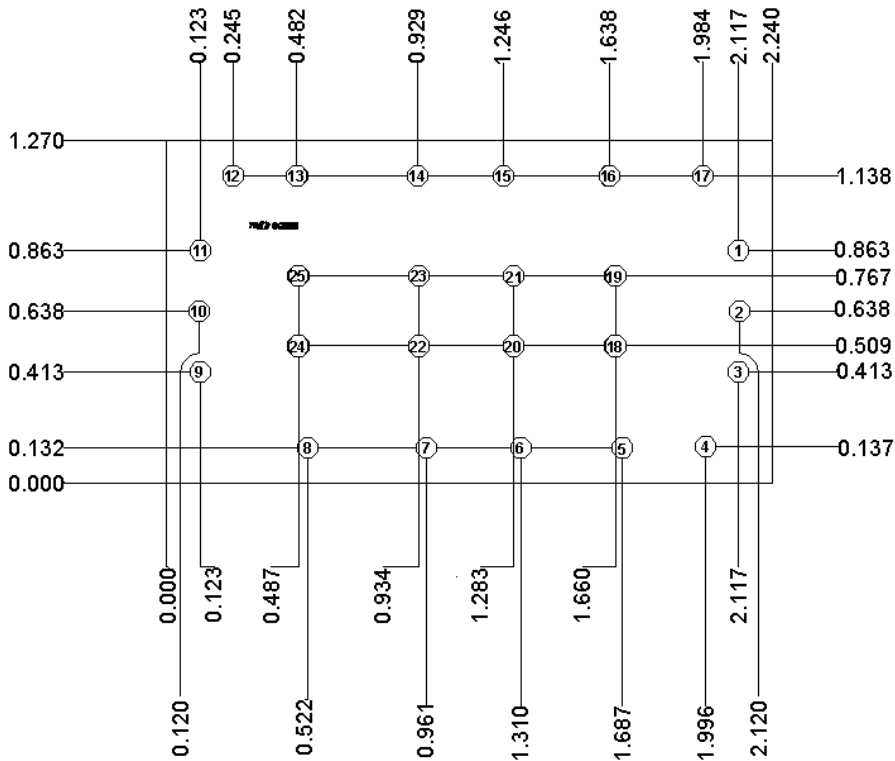

Units: millimeters

Thickness: 0.380

Die x,y size tolerance: +/- 0.050

Chip edge to pillar dimensions are shown to center of pillar

Pillar #4,12,18-25	DC Ground	0.075 Ø	Pillar #5	Vg4	0.075 Ø
Pillar #1, 3, 9, 11	RF CPW Ground	0.075 Ø	Pillar #13	Vd1	0.075 Ø
Pillar #2	RF Out	0.075 Ø	Pillar #14	Vd2	0.075 Ø
Pillar #10	RF In	0.075 Ø	Pillar #15	Vd3	0.075 Ø
Pillar #8	Vg1	0.075 Ø	Pillar #16	Vd4	0.075 Ø
Pillar #7	Vg2	0.075 Ø	Pillar #17	Mech. Support Only	0.075 Ø
Pillar #6	Vg3	0.075 Ø			

GaAs MMIC devices are susceptible to damage from Electrostatic Discharge. Proper precautions should be observed during handling, assembly and test.

Recommended Assembly Diagram

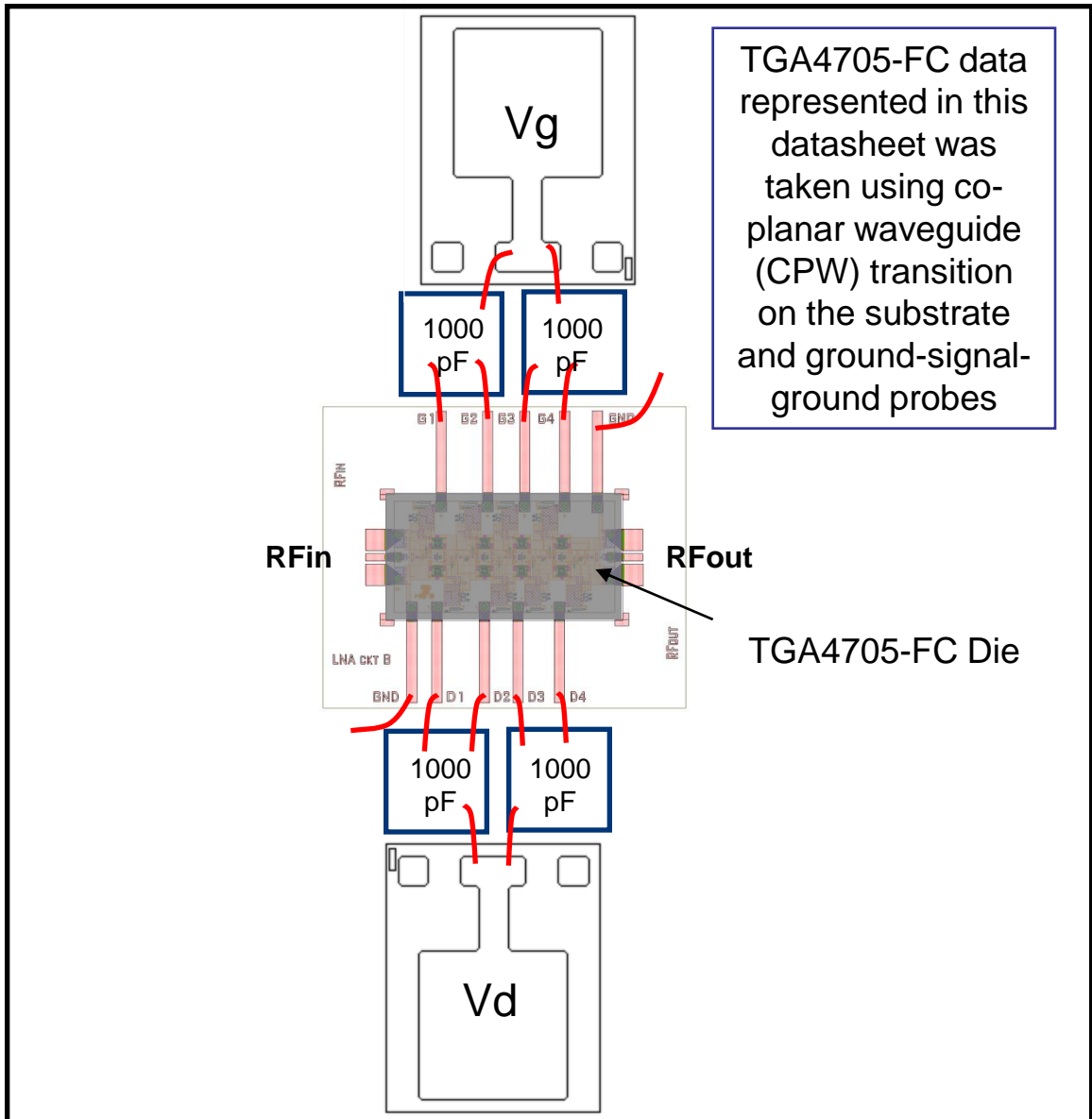

Die is flip-chip soldered to a 15 mil thick alumina test substrate

GaAs MMIC devices are susceptible to damage from Electrostatic Discharge. Proper precautions should be observed during handling, assembly and test.

Assembly Notes

Component placement and die attach assembly notes:

- Vacuum pencils and/or vacuum collets are the preferred method of pick up.
- Air bridges must be avoided during placement.
- Cu pillars on die are 65 um tall with a 22 um tall Sn solder cap.
- Recommended board metallization is evaporated TiW followed by nickel/gold at pillar attach interface. Ni is the adhesion layer for the solder and the gold keeps the Ni from oxidizing. The Au should be kept to a minimum to avoid embrittlement; suggested Au / Sn mass ratio must not exceed 8%.
- Au metallization is not recommended on traces due to solder wicking and consumption concerns. If Au traces are used, a physical solder barrier must be applied or designed into the pad area of the board. The barrier must be sufficient to keep the solder from undercutting the barrier.

Reflow process assembly notes:

- Minimum alloying temperatures 245 °C.
- Repeating reflow cycles is not recommended due to Sn consumption on the first reflow cycle.
- An alloy station or conveyor furnace with an inert atmosphere such as N2 should be used.
- Dip copper pillars in “no-clean flip chip” flux prior to solder attach. Suggest using a high temperature flux. Avoid exposing entire die to flux.
- If screen printing flux, use small apertures and minimize volume of flux applied.
- Coefficient of thermal expansion matching between the MMIC and the substrate/board is critical for long-term reliability.
- Devices must be stored in a dry nitrogen atmosphere.
- Suggested reflow will depend on board material and density.

Typical Reflow Profiles for TriQuint Cu / Sn Pillars

Process	Sn Reflow
Ramp-up Rate	3 °C/sec
Flux Activation Time and Temperature	60 – 120 sec @ 140 – 160 °C
Time above Melting Point (245 °C)	60 – 150 sec
Max Peak Temperature	300 °C
Time within 5 °C of Peak Temperature	10 – 20 sec
Ramp-down Rate	4 – 6 °C/sec

Ordering Information

Part	Package Style
TGA4705-FC	GaAs MMIC Die

GaAs MMIC devices are susceptible to damage from Electrostatic Discharge. Proper precautions should be observed during handling, assembly and test.



Стандарт Электрон Связь

Мы молодая и активно развивающаяся компания в области поставок электронных компонентов. Мы поставляем электронные компоненты отечественного и импортного производства напрямую от производителей и с крупнейших складов мира.

Благодаря сотрудничеству с мировыми поставщиками мы осуществляем комплексные и плановые поставки широчайшего спектра электронных компонентов.

Собственная эффективная логистика и склад в обеспечивает надежную поставку продукции в точно указанные сроки по всей России.

Мы осуществляем техническую поддержку нашим клиентам и предпродажную проверку качества продукции. На все поставляемые продукты мы предоставляем гарантию .

Осуществляем поставки продукции под контролем ВП МО РФ на предприятия военно-промышленного комплекса России , а также работаем в рамках 275 ФЗ с открытием отдельных счетов в уполномоченном банке. Система менеджмента качества компании соответствует требованиям ГОСТ ISO 9001.

Минимальные сроки поставки, гибкие цены, неограниченный ассортимент и индивидуальный подход к клиентам являются основой для выстраивания долгосрочного и эффективного сотрудничества с предприятиями радиоэлектронной промышленности, предприятиями ВПК и научно-исследовательскими институтами России.

С нами вы становитесь еще успешнее!

Наши контакты:

Телефон: +7 812 627 14 35

Электронная почта: sales@st-electron.ru

Адрес: 198099, Санкт-Петербург,
Промышленная ул, дом № 19, литера Н,
помещение 100-Н Офис 331