



MICROCHIP

**MCP6H04
Evaluation Board
User's Guide**

Note the following details of the code protection feature on Microchip devices:

- Microchip products meet the specification contained in their particular Microchip Data Sheet.
- Microchip believes that its family of products is one of the most secure families of its kind on the market today, when used in the intended manner and under normal conditions.
- There are dishonest and possibly illegal methods used to breach the code protection feature. All of these methods, to our knowledge, require using the Microchip products in a manner outside the operating specifications contained in Microchip's Data Sheets. Most likely, the person doing so is engaged in theft of intellectual property.
- Microchip is willing to work with the customer who is concerned about the integrity of their code.
- Neither Microchip nor any other semiconductor manufacturer can guarantee the security of their code. Code protection does not mean that we are guaranteeing the product as "unbreakable."

Code protection is constantly evolving. We at Microchip are committed to continuously improving the code protection features of our products. Attempts to break Microchip's code protection feature may be a violation of the Digital Millennium Copyright Act. If such acts allow unauthorized access to your software or other copyrighted work, you may have a right to sue for relief under that Act.

Information contained in this publication regarding device applications and the like is provided only for your convenience and may be superseded by updates. It is your responsibility to ensure that your application meets with your specifications. MICROCHIP MAKES NO REPRESENTATIONS OR WARRANTIES OF ANY KIND WHETHER EXPRESS OR IMPLIED, WRITTEN OR ORAL, STATUTORY OR OTHERWISE, RELATED TO THE INFORMATION, INCLUDING BUT NOT LIMITED TO ITS CONDITION, QUALITY, PERFORMANCE, MERCHANTABILITY OR FITNESS FOR PURPOSE. Microchip disclaims all liability arising from this information and its use. Use of Microchip devices in life support and/or safety applications is entirely at the buyer's risk, and the buyer agrees to defend, indemnify and hold harmless Microchip from any and all damages, claims, suits, or expenses resulting from such use. No licenses are conveyed, implicitly or otherwise, under any Microchip intellectual property rights.

Trademarks

The Microchip name and logo, the Microchip logo, dsPIC, KEELOQ, KEELOQ logo, MPLAB, PIC, PICmicro, PICSTART, PIC³² logo, rfPIC and UNI/O are registered trademarks of Microchip Technology Incorporated in the U.S.A. and other countries.

FilterLab, Hampshire, HI-TECH C, Linear Active Thermistor, MXDEV, MXLAB, SEEVAL and The Embedded Control Solutions Company are registered trademarks of Microchip Technology Incorporated in the U.S.A.

Analog-for-the-Digital Age, Application Maestro, chipKIT, chipKIT logo, CodeGuard, dsPICDEM, dsPICDEM.net, dsPICworks, dsSPEAK, ECAN, ECONOMONITOR, FanSense, HI-TIDE, In-Circuit Serial Programming, ICSP, Mindi, MiWi, MPASM, MPLAB Certified logo, MPLIB, MPLINK, mTouch, Omniscient Code Generation, PICC, PICC-18, PICDEM, PICDEM.net, PICkit, PICtail, REAL ICE, rfLAB, Select Mode, Total Endurance, TSHARC, UniWinDriver, WiperLock and ZENA are trademarks of Microchip Technology Incorporated in the U.S.A. and other countries.

SQTP is a service mark of Microchip Technology Incorporated in the U.S.A.

All other trademarks mentioned herein are property of their respective companies.

© 2011, Microchip Technology Incorporated, Printed in the U.S.A., All Rights Reserved.

 Printed on recycled paper.

ISBN: 978-1-61341-737-9

QUALITY MANAGEMENT SYSTEM
CERTIFIED BY DNV
== ISO/TS 16949:2009 ==

Microchip received ISO/TS-16949:2009 certification for its worldwide headquarters, design and wafer fabrication facilities in Chandler and Tempe, Arizona; Gresham, Oregon and design centers in California and India. The Company's quality system processes and procedures are for its PIC[®] MCUs and dsPIC[®] DSCs, KEELOQ[®] code hopping devices, Serial EEPROMs, microperipherals, nonvolatile memory and analog products. In addition, Microchip's quality system for the design and manufacture of development systems is ISO 9001:2000 certified.

Table of Contents

Preface	5
Introduction.....	5
Document Layout	5
Conventions Used in this Guide	6
Recommended Reading.....	7
The Microchip Web Site	7
Customer Support	7
Document Revision History	7
 Chapter 1. Product Overview	
1.1 Introduction	9
1.2 Board Description	9
1.3 What the MCP6H04 Evaluation Board Kit Includes	10
 Chapter 2. Installation and Operation	
2.1 Introduction	11
2.2 Required Tools	11
2.3 MCP6H04 Evaluation Board Set-Up	11
2.3.1 Top Level Amplifier Circuit Diagram	13
2.4 MCP6H04 Evaluation Board Operation	15
2.4.1 Building the Amplifier	15
2.4.2 Testing the Amplifier	18
 Appendix A. Schematic and Layouts	
A.1 Introduction	25
A.2 Board – Schematic	26
A.3 Board – Silk and Solder Mask	27
A.4 Board – Top Metal Layer	27
A.5 Board – Bottom Metal Layer (Bottom View)	28
 Appendix B. Bill of Materials	
Worldwide Sales and Service	30

MCP6H04 Evaluation Board User's Guide

NOTES:

Preface

NOTICE TO CUSTOMERS

All documentation becomes dated, and this manual is no exception. Microchip tools and documentation are constantly evolving to meet customer needs, so some actual dialogs and/or tool descriptions may differ from those in this document. Please refer to our web site (www.microchip.com) to obtain the latest documentation available.

Documents are identified with a “DS” number. This number is located on the bottom of each page, in front of the page number. The numbering convention for the DS number is “DSXXXXA”, where “XXXX” is the document number and “A” is the revision level of the document.

For the most up-to-date information on development tools, see the MPLAB® IDE online help. Select the Help menu, and then Topics to open a list of available online help files.

INTRODUCTION

This chapter contains general information that will be useful to know before using the MCP6H04 Evaluation Board. Items discussed in this chapter include:

- Document Layout
- Conventions Used in this Guide
- Recommended Reading
- The Microchip Web Site
- Customer Support
- Document Revision History

DOCUMENT LAYOUT

This document describes how to use the MCP6H04 Evaluation Board. The manual layout is as follows:

- **Chapter 1. “Product Overview”** – Important information about the MCP6H04 Evaluation Board.
- **Chapter 2. “Installation and Operation”** – Includes instructions on how to set up and operate the MCP6H04 Evaluation Board.
- **Appendix A. “Schematic and Layouts”** – Shows the schematic and layout diagrams for the MCP6H04 Evaluation Board.
- **Appendix B. “Bill of Materials”** – Lists the parts used to build the MCP6H04 Evaluation Board.

MCP6H04 Evaluation Board User's Guide

CONVENTIONS USED IN THIS GUIDE

This manual uses the following documentation conventions:

DOCUMENTATION CONVENTIONS

Description	Represents	Examples
Arial font:		
Italic characters	Referenced books	<i>MPLAB[®] IDE User's Guide</i>
	Emphasized text	...is the <i>only</i> compiler...
Initial caps	A window	the Output window
	A dialog	the Settings dialog
	A menu selection	select Enable Programmer
Quotes	A field name in a window or dialog	"Save project before build"
Underlined, italic text with right angle bracket	A menu path	<u><i>File>Save</i></u>
Bold characters	A dialog button	Click OK
	A tab	Click the Power tab
N'Rnnnn	A number in verilog format, where N is the total number of digits, R is the radix and n is a digit.	4'b0010, 2'hF1
Text in angle brackets < >	A key on the keyboard	Press <Enter>, <F1>
Courier New font:		
Plain Courier New	Sample source code	#define START
	Filenames	autoexec.bat
	File paths	c:\mcc18\h
	Keywords	_asm, _endasm, static
	Command-line options	-Opa+, -Opa-
	Bit values	0, 1
	Constants	0xFF, 'A'
Italic Courier New	A variable argument	<i>file.o</i> , where <i>file</i> can be any valid filename
Square brackets []	Optional arguments	mcc18 [options] <i>file</i> [options]
Curly brackets and pipe character: { }	Choice of mutually exclusive arguments; an OR selection	errorlevel {0 1}
Ellipses...	Replaces repeated text	var_name [, var_name...]
	Represents code supplied by user	void main (void) { ... }

RECOMMENDED READING

This user's guide describes how to use the MCP6H04 Evaluation Board. Other useful documents are listed below. The following Microchip document is available and recommended as a supplemental reference resource.

- **MCP6H01/2/4 - "1.2 MHz, 16V Op Amps" (DS22243)**

THE MICROCHIP WEB SITE

Microchip provides online support via our web site at www.microchip.com. This web site is used as a means to make files and information easily available to customers. Accessible by using your favorite Internet browser, the web site contains the following information:

- **Product Support** – Data sheets and errata, application notes and sample programs, design resources, user's guides and hardware support documents, latest software releases and archived software
- **General Technical Support** – Frequently Asked Questions (FAQs), technical support requests, online discussion groups, Microchip consultant program member listing
- **Business of Microchip** – Product selector and ordering guides, latest Microchip press releases, listing of seminars and events, listings of Microchip sales offices, distributors and factory representatives

CUSTOMER SUPPORT

Users of Microchip products can receive assistance through several channels:

- Distributor or Representative
- Local Sales Office
- Field Application Engineer (FAE)
- Technical Support

Customers should contact their distributor, representative or field application engineer (FAE) for support. Local sales offices are also available to help customers. A listing of sales offices and locations is included in the back of this document.

Technical support is available through the web site at: <http://www.microchip.com/support>.

DOCUMENT REVISION HISTORY

Revision A (October 2011)

- Initial Release of this Document.

MCP6H04 Evaluation Board User's Guide

NOTES:

Chapter 1. Product Overview

1.1 INTRODUCTION

The MCP6H04 Evaluation Board is described as follows:

- Assembly #:114-00375-R2
- Order#: MCP6H04EV
- Name: MCP6H04 Evaluation Board

1.2 BOARD DESCRIPTION

The MCP6H04 Evaluation Board is intended to support an instrumentation amplifier and show the capability of the MCP6H04 operational amplifier. The board has the following features:

- All amplifier resistors and capacitors are socketed
- Supports MCP6H04 Microchip quad op amp
 - SOIC-14 package
- Test points for connection to lab equipment
- Single supply configuration

Figure 1-1 shows the block diagram of the MCP6H04 Evaluation Board. Lab equipment can be attached (via test points) to measure the amplifier response.

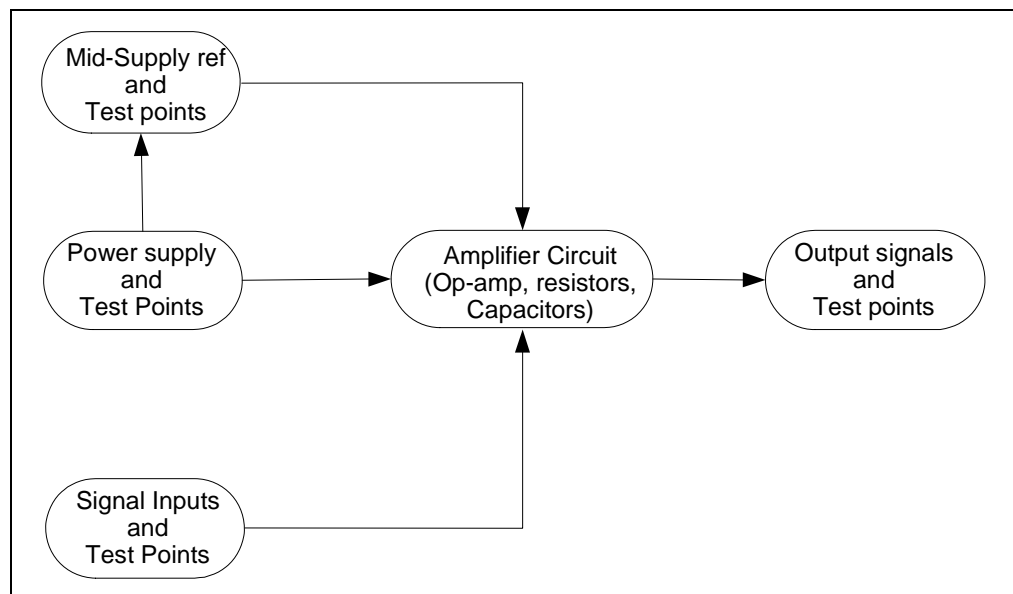

FIGURE 1-1: MCP6H04 Evaluation Board - Block Diagram.

MCP6H04 Evaluation Board User's Guide

1.3 WHAT THE MCP6H04 EVALUATION BOARD KIT INCLUDES

- MCP6H04 Evaluation Board, 102-00375
- Important Information Sheet
- Accessories Bag – contains loose parts for populating sockets on board, such as resistors and capacitors



FIGURE 1-2: MCP6H04 Evaluation Board View.

Chapter 2. Installation and Operation

2.1 INTRODUCTION

This chapter describes how to set up the MCP6H04 Evaluation Board. Topics discussed in this chapter include:

- Required Tools
- MCP6H04 Evaluation Board Set-Up
- MCP6H04 Evaluation Board Operation

2.2 REQUIRED TOOLS

The following tools are required for testing the functionality of the board:

- Lab power supply
- Lab dual signal source (e.g., dual function generator)
- Lab measurement equipment (e.g., oscilloscope)

2.3 MCP6H04 EVALUATION BOARD SET-UP

The MCP6H04 Evaluation Board uses a quad op amp in difference amplifier configuration with input buffers and voltage reference. Figure 2-1 shows the circuit diagram of the board.

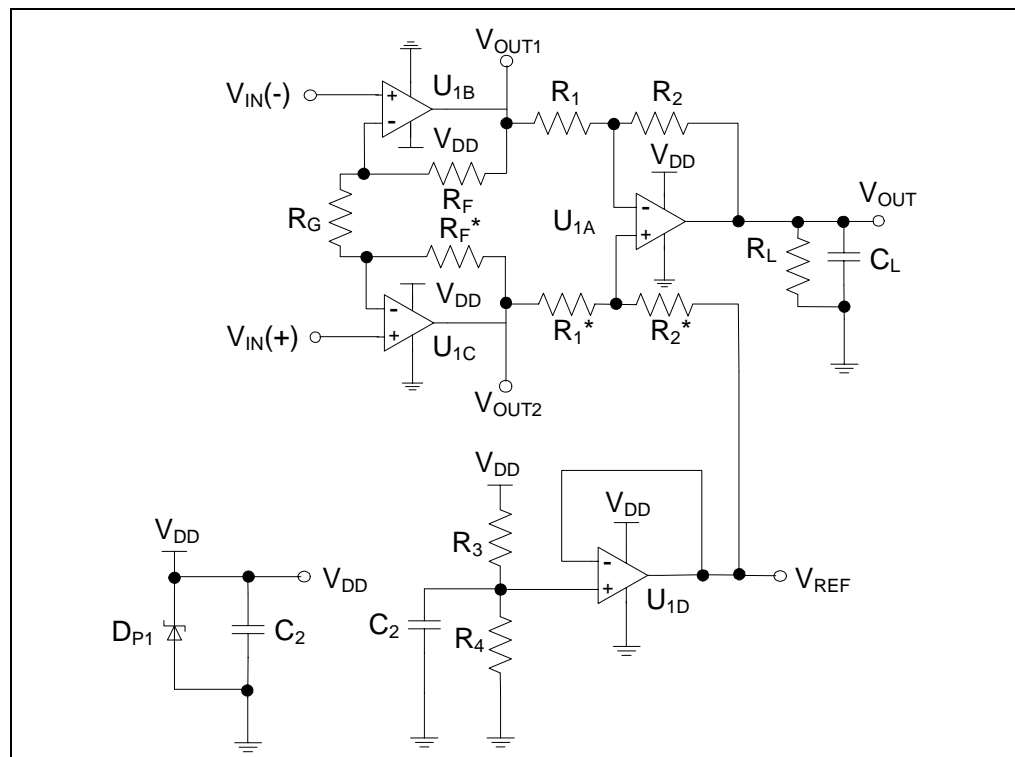

FIGURE 2-1: MCP6H04 Evaluation Board Circuit Diagram.

MCP6H04 Evaluation Board User's Guide

The power supply voltage needs to be in the allowed range for the op amp. The MCP6H04 device supports a maximum of 16V power supply. The power supply is protected by a Zener diode with a nominal voltage of 16V and bypassed by a 1 μ F capacitor (see Figure 2-3).

The mid-supply reference voltage consists of a voltage divider and a buffer amplifier (see Figure 2-4).

The resistors that are part of the amplifier are placed in pin sockets, which are labeled.

All component labels on board are consistent with those on the schematic. The op amp on board is a 14-lead SOIC package, and is bypassed by a 0.1 μ F capacitor.

The test points for the power supply, ground, input signals, output signals, and voltage reference allow lab equipment to be connected to the board. The MCP6H04 Evaluation Board top view is shown in Figure 2-2.

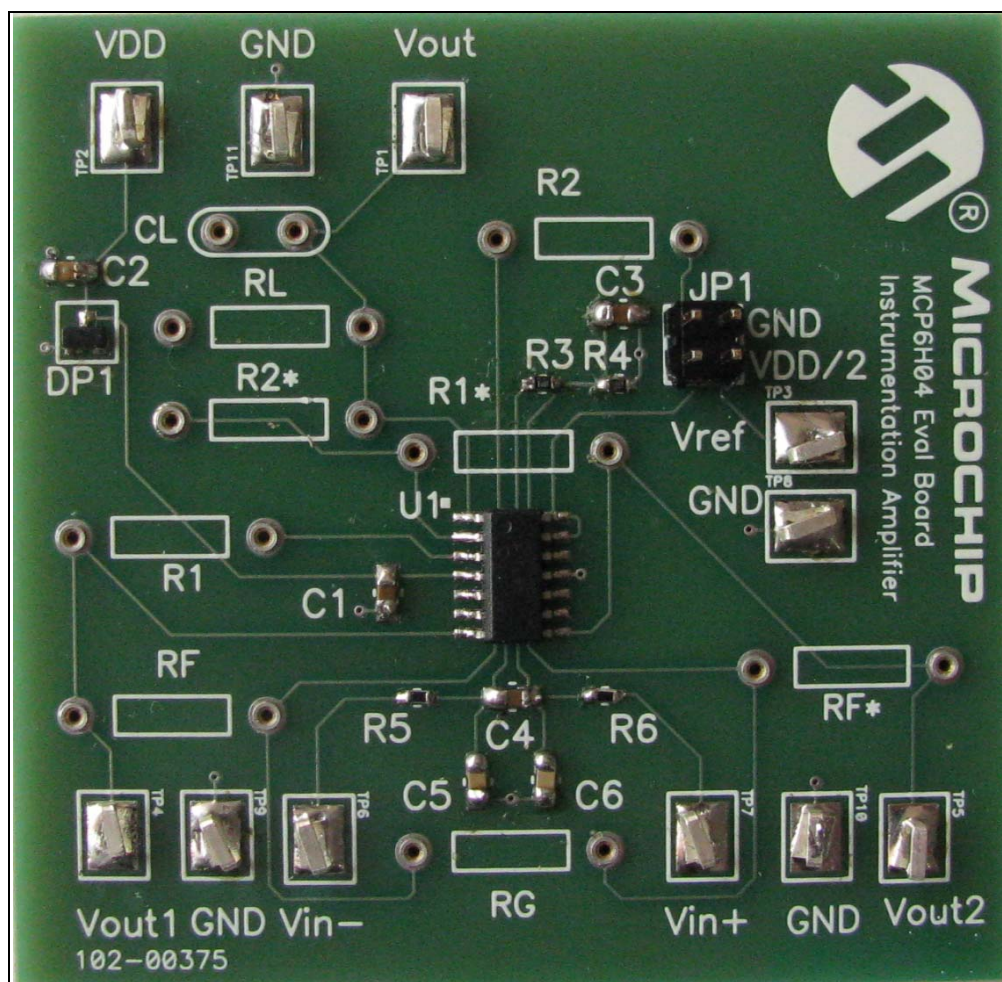

FIGURE 2-2: MCP6H04 Evaluation Board Top View.

2.3.1 Top Level Amplifier Circuit Diagram

2.3.1.1 POWER SUPPLY BLOCK

The power supply is protected by a Zener diode and bypassed by a capacitor. Figure 2-3 shows the circuit diagram for the power supply ($C_2 = 1 \mu\text{F}$). D_{P1} is a Zener diode with a nominal voltage of 16V.

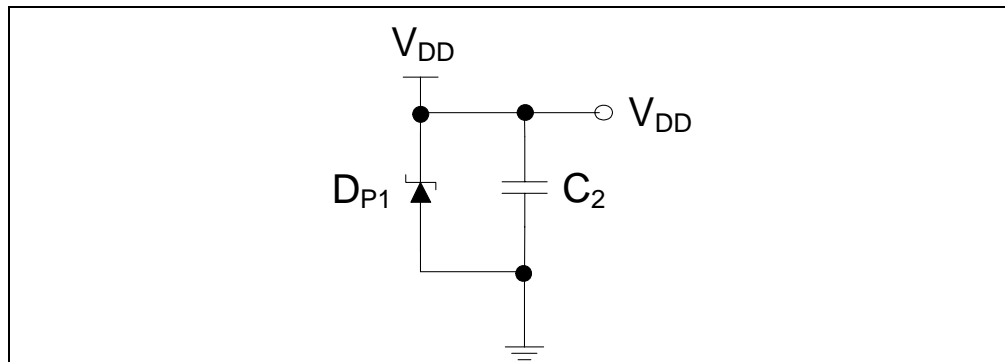

FIGURE 2-3: Circuit Diagram for Power Supply.

2.3.1.2 MID-SUPPLY REFERENCE BLOCK

The mid-supply reference consists of a voltage divider and a buffer amplifier. Figure 2-4 shows the circuit diagram for the mid-supply reference ($R_3 = R_4 = 100\text{K}$, $C_3 = 0.1 \mu\text{F}$).

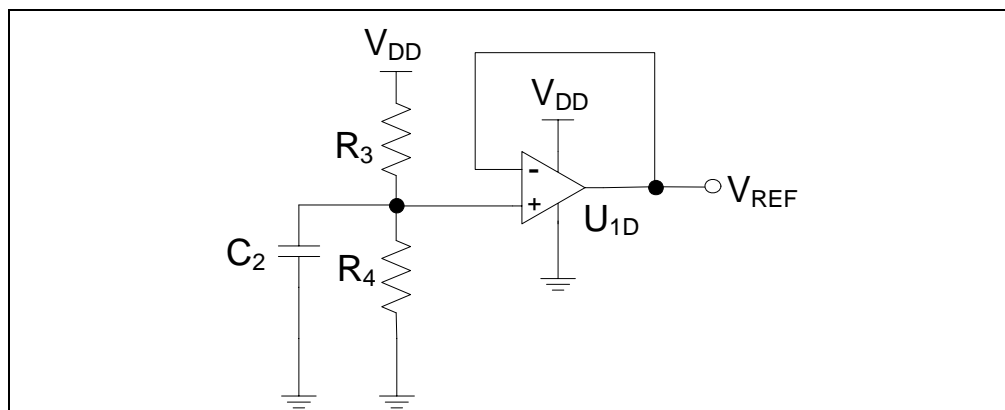

FIGURE 2-4: Mid-Supply Reference Block.

2.3.1.3 OUTPUT LOAD BLOCK

The output load consists of a capacitor and a resistor. Figure 2-5 shows the circuit diagram of the output load ($R_L = 10\text{K}$, $C_L = 56 \text{ pF}$).

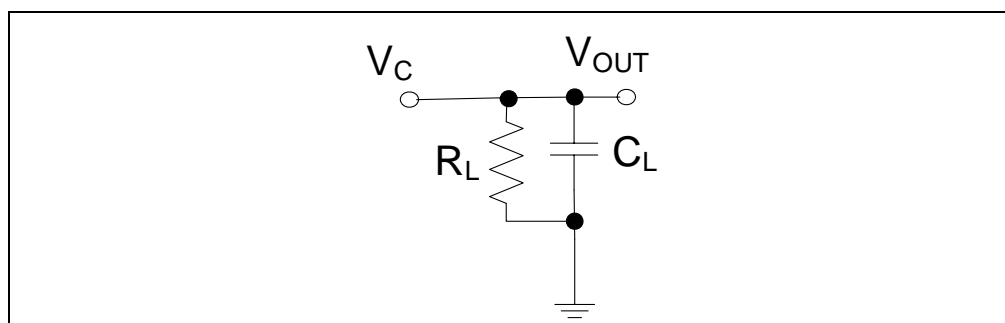

FIGURE 2-5: Output Load Block.

MCP6H04 Evaluation Board User's Guide

2.3.1.4 INPUT STAGE

The input stage consists of two resistors and three capacitors. All three capacitors are forming a noise filter. Figure 2-6 shows the circuit diagram of the input stage ($C_5 = C_6 = 10$ nF, $C_4 = 100$ nF and $R_5 = R_6 = 1$ K).

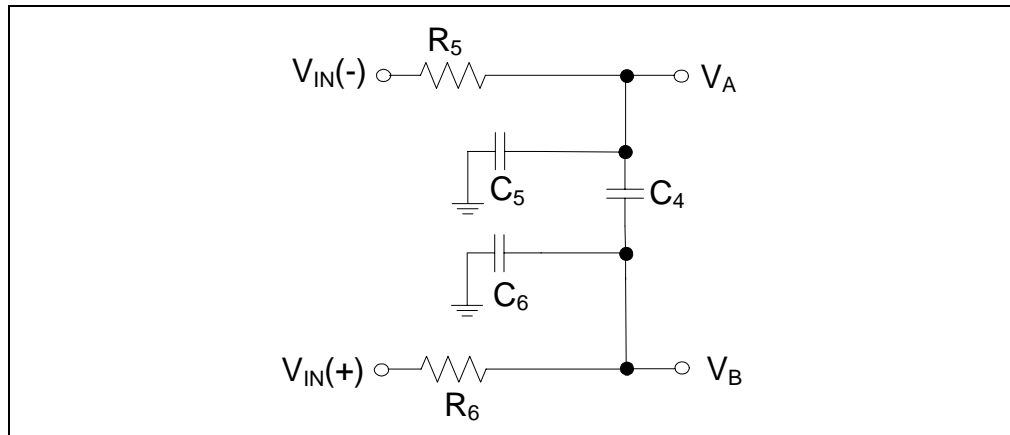

FIGURE 2-6: *Input Stage Block.*

2.3.1.5 INPUT BUFFER BLOCK

The input buffer block consists of two op amps in buffer configuration with outputs tied together through one resistor. Figure 2-7 shows the circuit diagram of the input buffer block ($R_F = R_F^* = 50$ K, $R_G = 1$ K).

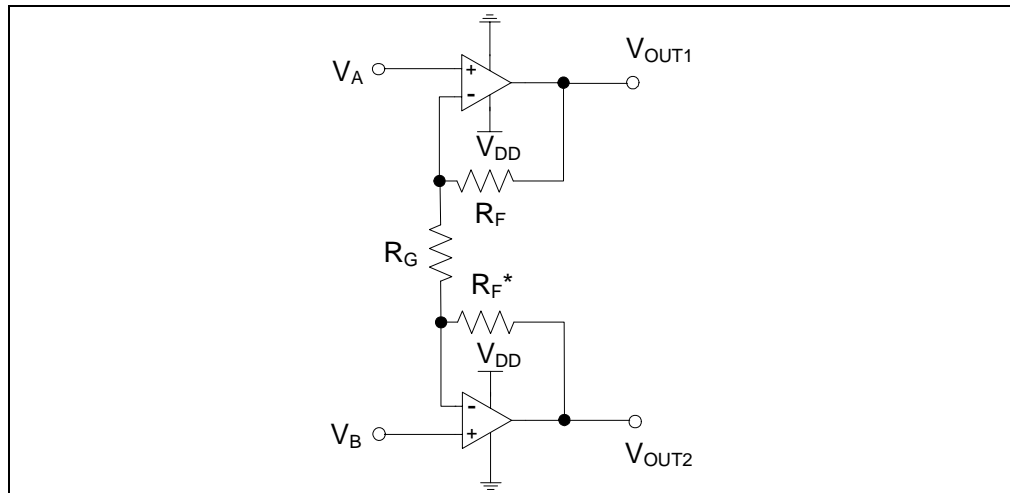

FIGURE 2-7: *Input Buffer Block.*

2.3.1.6 DIFFERENCE AMPLIFIER

This circuit amplifies the difference between two voltages, while rejecting the Common mode input voltage. Output voltage can be shifted by a reference voltage for single supply operation.

Fill the sockets with the recommended resistors and capacitors (see the circuit diagram shown in Figure 2-8).

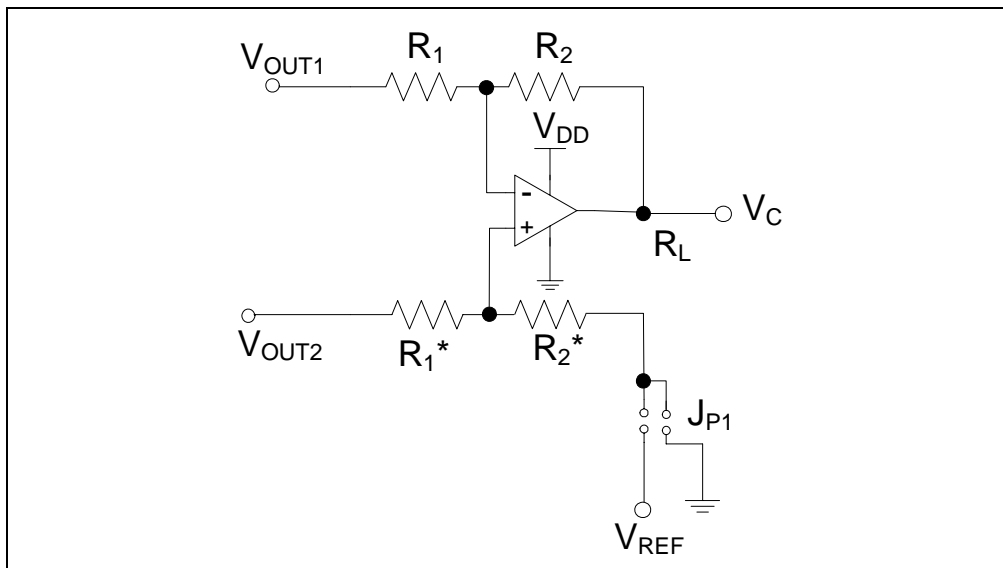

FIGURE 2-8: Difference Amplifier Block.

The jumper positions have the following effect:

- JP1 connected to ground: the output voltage will be centered on 0V.
- JP1 connected to V_{REF} : the output voltage will be centered on 8V.

2.4 MCP6H04 EVALUATION BOARD OPERATION

This section covers the following topics:

- Building the Amplifier
- Testing the Amplifier

2.4.1 Building the Amplifier

The accessory bag that comes with this kit facilitates the evaluation of the amplifier described below.

The amplifier characteristics are:

- Instrumentation amplifier (Single supply operation)
- Power supply voltage = 16V
- Desired Gain = 101 V/V
- Load Capacitance = 56 pF

MCP6H04 Evaluation Board User's Guide

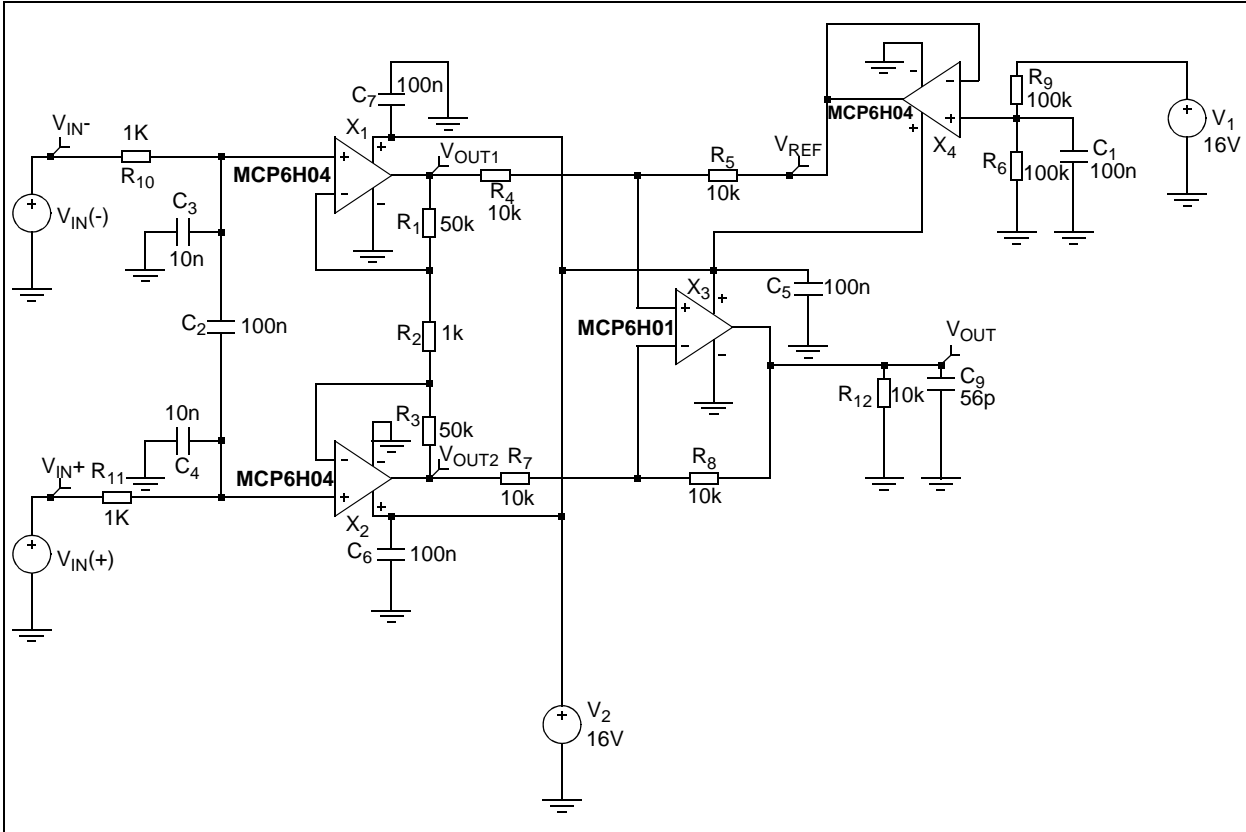

FIGURE 2-9: Schematic of the Instrumentation Amplifier Designed for Simulation.

Installation and Operation

Figure 2-10 shows the same circuit redrawn to emphasize the instrumentation amplifier.

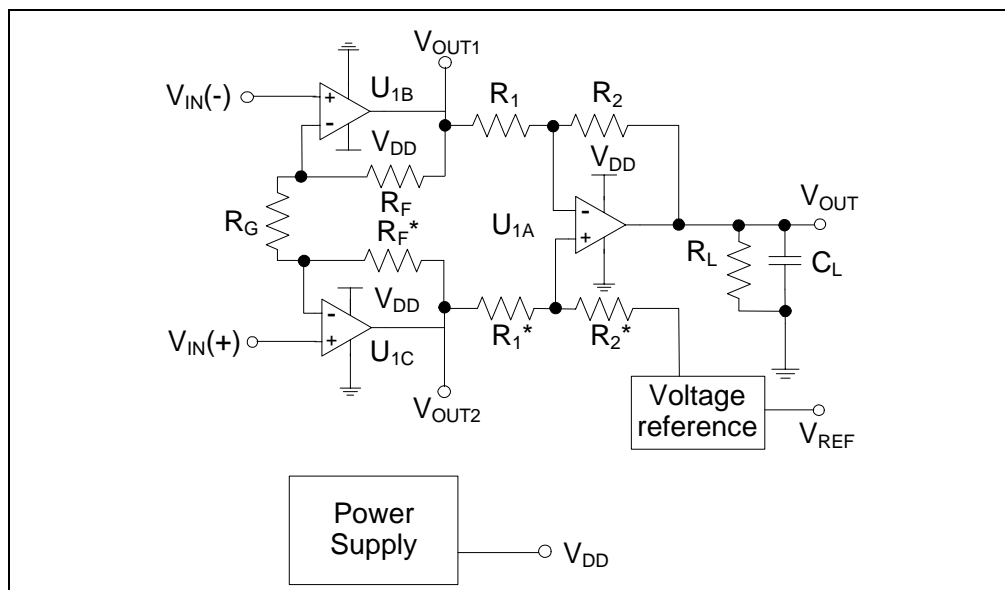

FIGURE 2-10: Instrumentation Amplifier Diagram Block.

Each of the components in Figure 2-10 that need to be inserted in a socket on the MCP6H04 Evaluation Board is listed in Table 2-1 and Table 2-2. The op amp is soldered on the PCB.

TABLE 2-1: AMPLIFIER COMPONENTS LIST

PCB Labels	Component Value
R_F	50K
R_F^*	50K
R_G	1K
R_1	10K
R_1^*	10K
R_2	10K
R_2^*	10K
R_L	10K
C_L	56 pF

TABLE 2-2: JUMPER POSITIONS

Jumper	Position
JP1	$V_{DD}/2$
	GND

MCP6H04 Evaluation Board User's Guide

The fully assembled MCP6H04 Evaluation Board top view is shown in Figure 2-11.

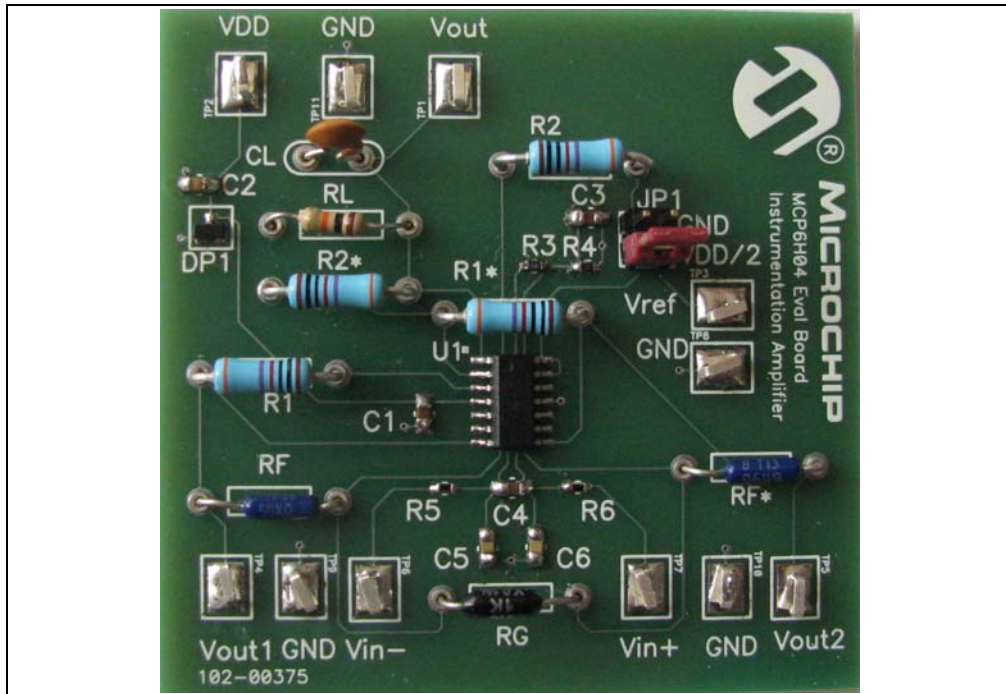

FIGURE 2-11: MCP6H04 Evaluation Board Top View.

2.4.2 Testing the Amplifier

2.4.2.1 CHECKING THE TEST POINTS

The test points for the power supply, ground, input signals and output signals allow lab equipment to be connected to the board. Figure 2-12 shows the test points to check.

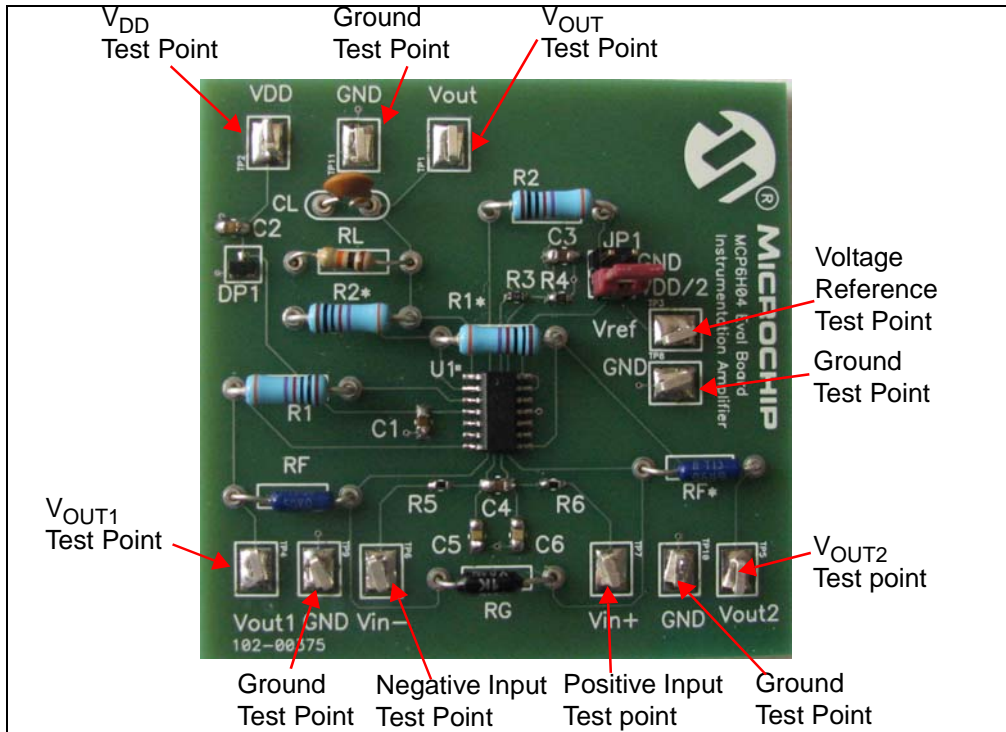

FIGURE 2-12: Check-in Test Points.

2.4.2.2 BOARD VALIDATION

All resistors in sockets have 0.1% tolerance and all soldered resistors have 1% tolerance. The capacitors have 20% tolerance.

2.4.2.2.1 Sine Wave Response

Settings in bench measurement:

- Set V_{IN} for Source(-) at 10 mV, 10 Hz, 0° phase and a Common mode voltage of 4V
- Set V_{IN} for Source(+) at 10 mV, 10 Hz, 180° phase and a Common mode voltage of 4V
- $V_{REF} = V_{DD}/2$
- $V_{DD} = 16V$
- The output signal is centered on 8V
- The amplifier's Gain is 101 V/V

Figure 2-13 shows the result of this measurement.

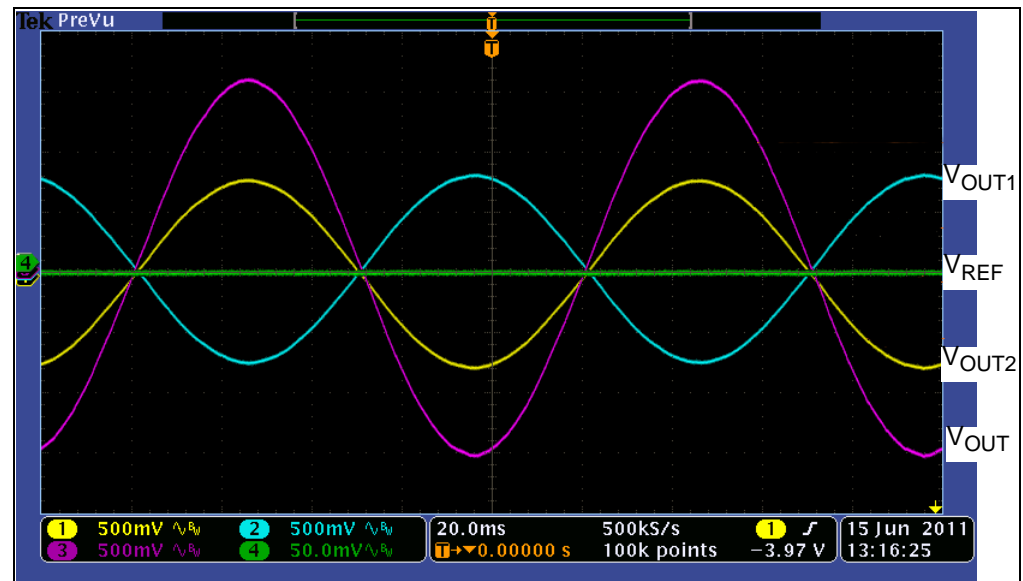

FIGURE 2-13: Sine Wave Response.

Simulation settings:

- Set V_{IN} for Source(-) at 10 mV, 10 Hz, 0° phase and Common mode voltage 4V
- Set V_{IN} for Source(+) at 10 mV, 10 Hz, 180° phase and Common mode voltage 4V
- $V_{REF} = V_{DD}/2$
- $V_{DD} = 16V$
- The output signal is centered on 8V
- The amplifier's Gain is 101 V/V

Figure 2-14 shows the results.

MCP6H04 Evaluation Board User's Guide

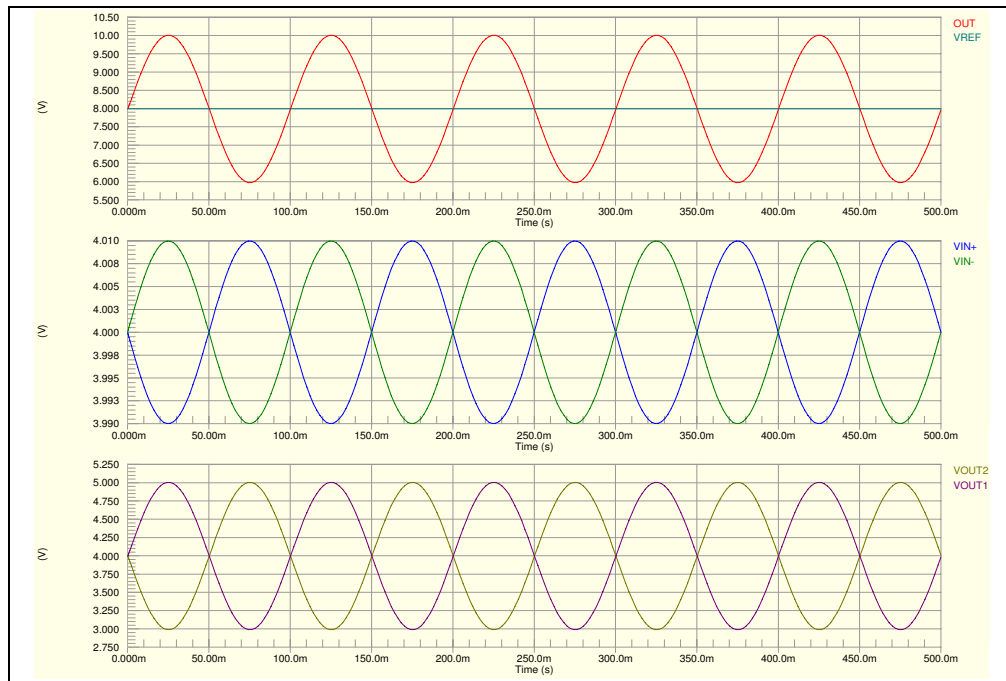

FIGURE 2-14: Simulation of the Sine Wave Response.

2.4.2.2.2 Square Wave Response

Settings in bench measurement:

- Set V_{IN} for Source(-) at 50 mV, 10 Hz, 0° phase and Common mode voltage 4V
- Set V_{IN} for Source(+) at 50 mV, 10 Hz, 180° phase and Common mode voltage 4V
- $V_{REF} = V_{DD}/2$
- $V_{DD} = 16V$
- The output signal is centered on 8V
- The amplifier's Gain is 101V/V

Figure 2-15 shows the result of this measurement.

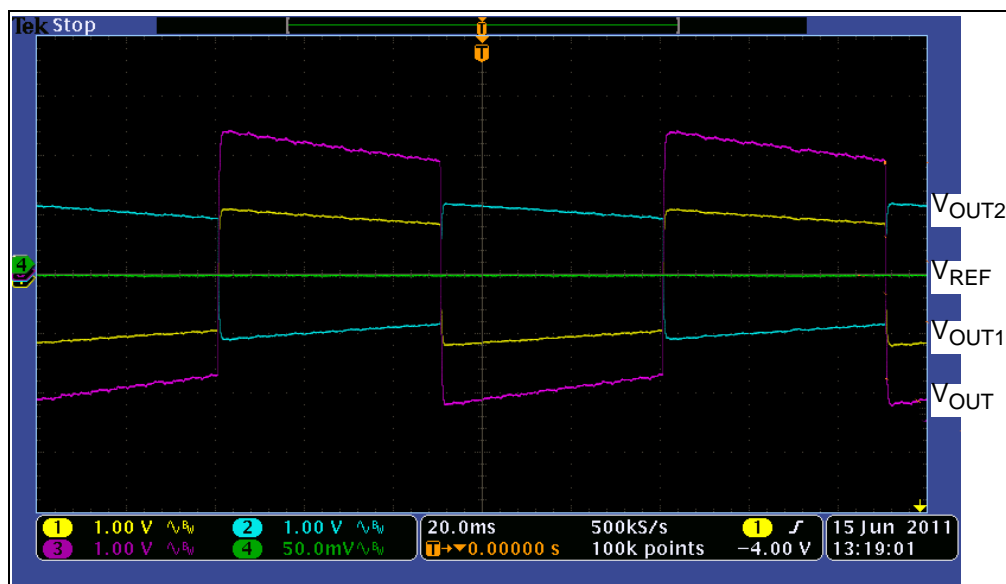

FIGURE 2-15: Square Wave Response.

Installation and Operation

Simulation settings:

- Set V_{IN} for Source(-) at 50 mV, 10 Hz, 0° phase and common mode voltage 4V
- Set V_{IN} for Source(+) at 50 mV, 10 Hz, 180° phase and common mode voltage 4V
- $V_{REF} = V_{DD}/2$
- $V_{DD}=16V$
- The output signal is centered on 8V
- The amplifier's Gain is 101V/V

Figure 2-16 shows the result of this simulation.

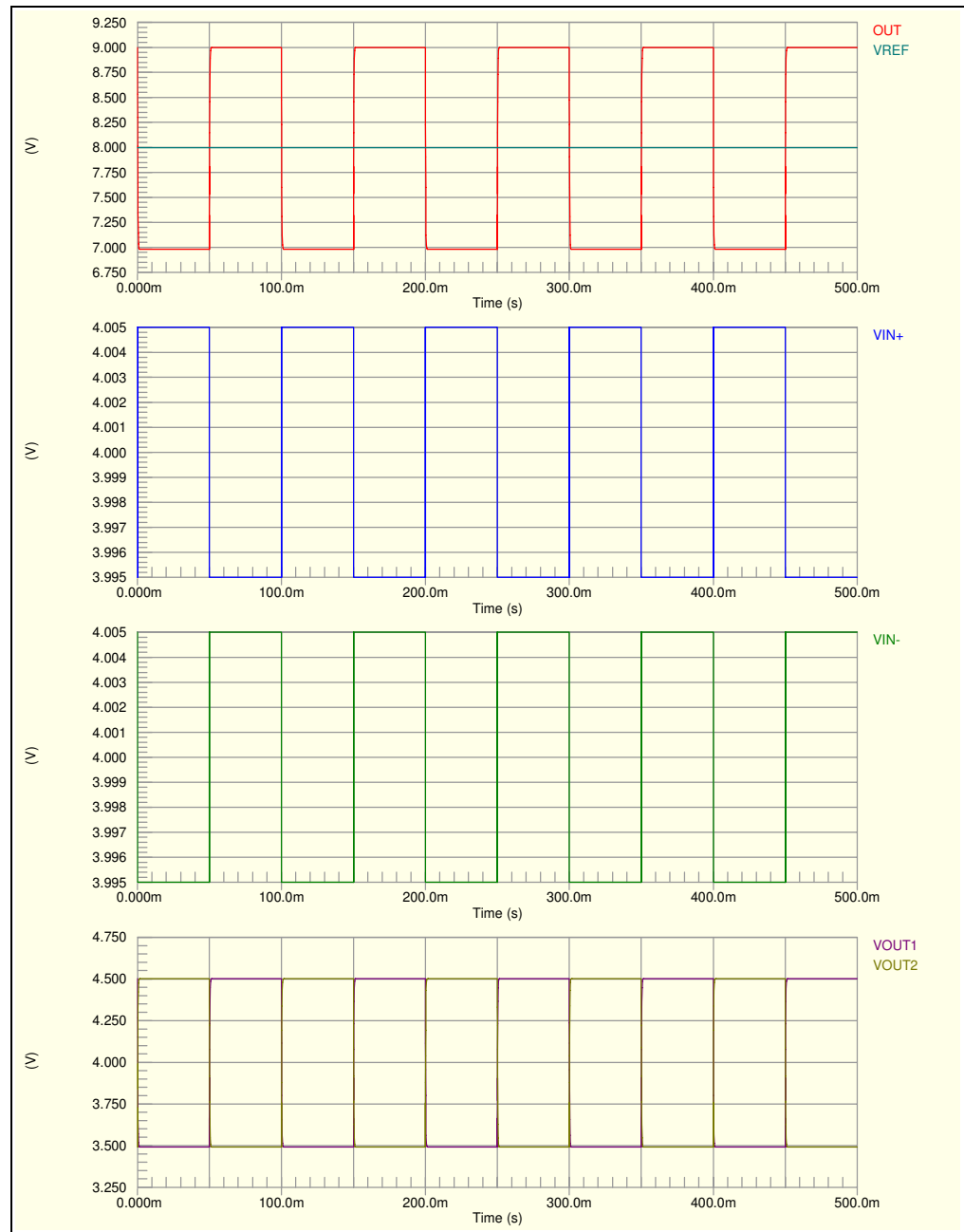

FIGURE 2-16: Simulation of the Square Wave Response.

MCP6H04 Evaluation Board User's Guide

2.4.2.2.3 DC Response

Settings in bench measurement:

- Set V_{IN} for Source(-) at 80 mV DC signal
- Set V_{IN} for Source(+) at 30 mV DC signal
- $V_{REF} = V_{DD}/2$
- $V_{DD} = 16V$

Figure 2-17 shows the result of this measurement.

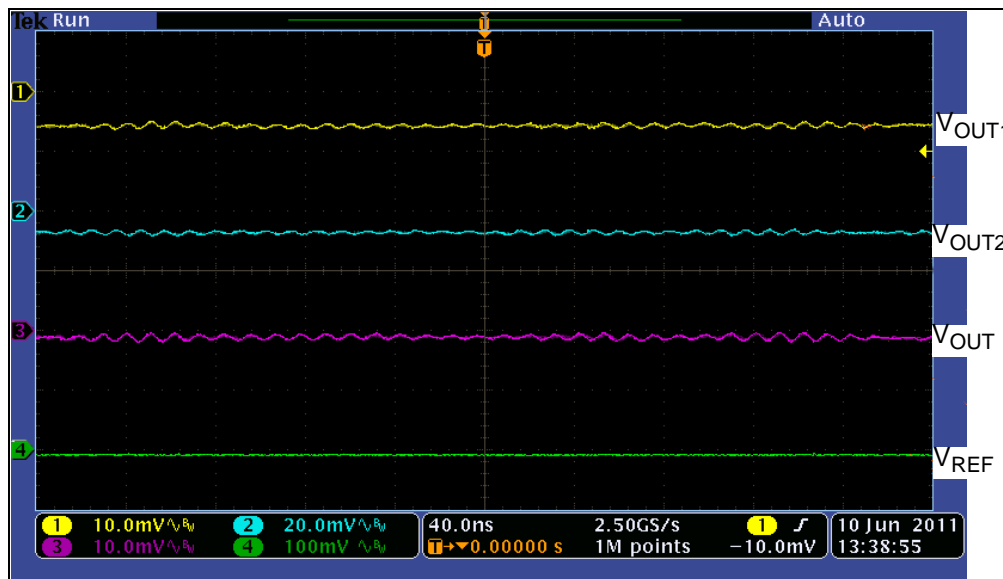

FIGURE 2-17: DC Response.

Simulation settings:

- Set V_{IN} for Source(-) at 80 mV DC signal
- Set V_{IN} for Source(+) at 30 mV DC signal
- $V_{REF} = V_{DD}/2$
- $V_{DD} = 16V$

Figure 2-18 shows the result of this measurement.

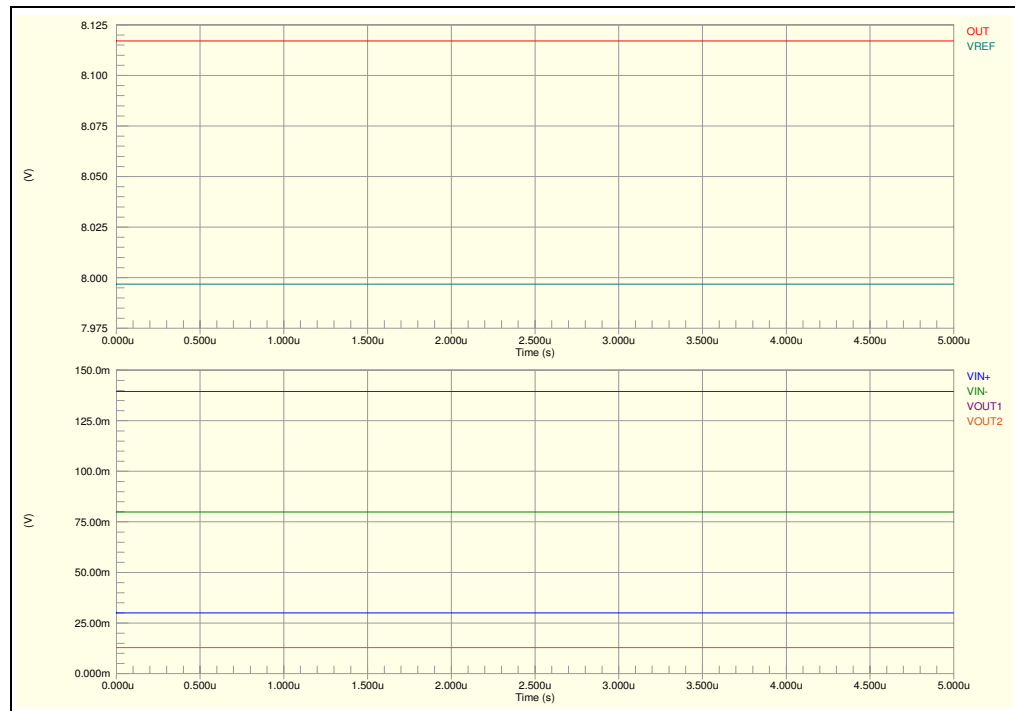

FIGURE 2-18: Simulation of the DC Response.

MCP6H04 Evaluation Board User's Guide

NOTES:



MCP6H04 EVALUATION BOARD USER'S GUIDE

Appendix A. Schematic and Layouts

A.1 INTRODUCTION

This appendix contains the following schematics and layouts of the MCP6H04 Evaluation Board:

- Board – Schematic
- Board – Silk and Solder Mask
- Board – Top Metal Layer
- Board – Bottom Metal Layer (bottom View)

MCP6H04 Evaluation Board User's Guide

A.2 BOARD – SCHEMATIC

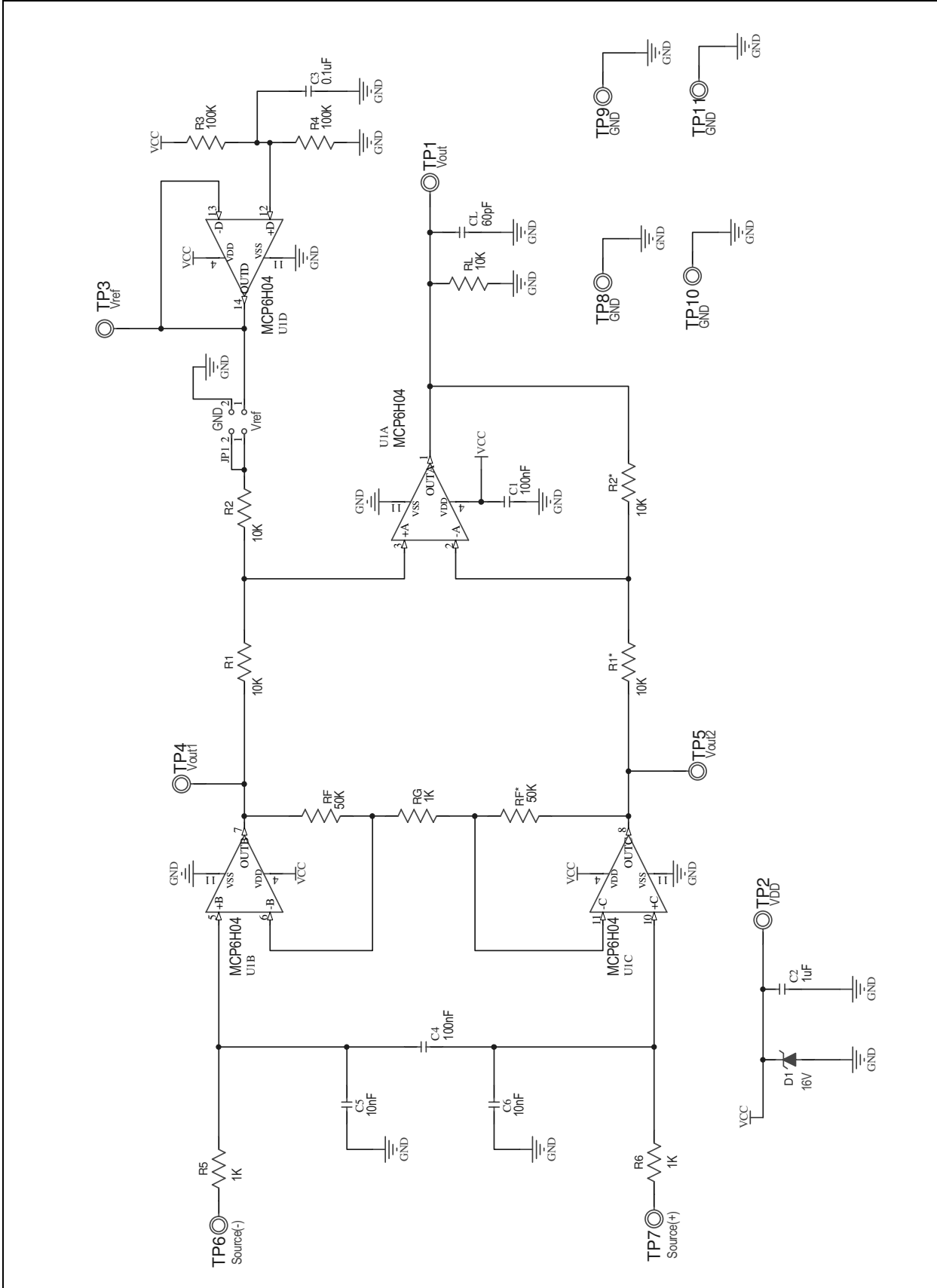

A.3 BOARD – SILK AND SOLDER MASK

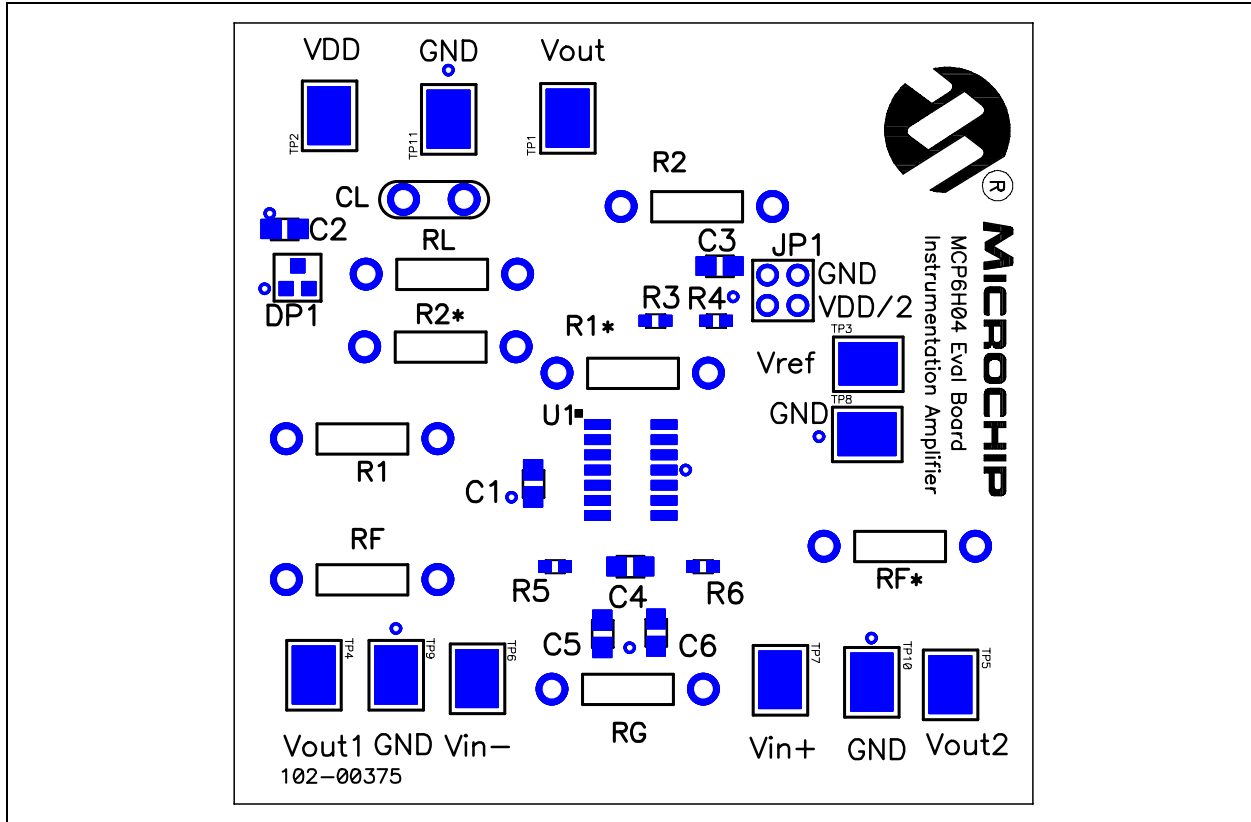

A.4 BOARD – TOP METAL LAYER

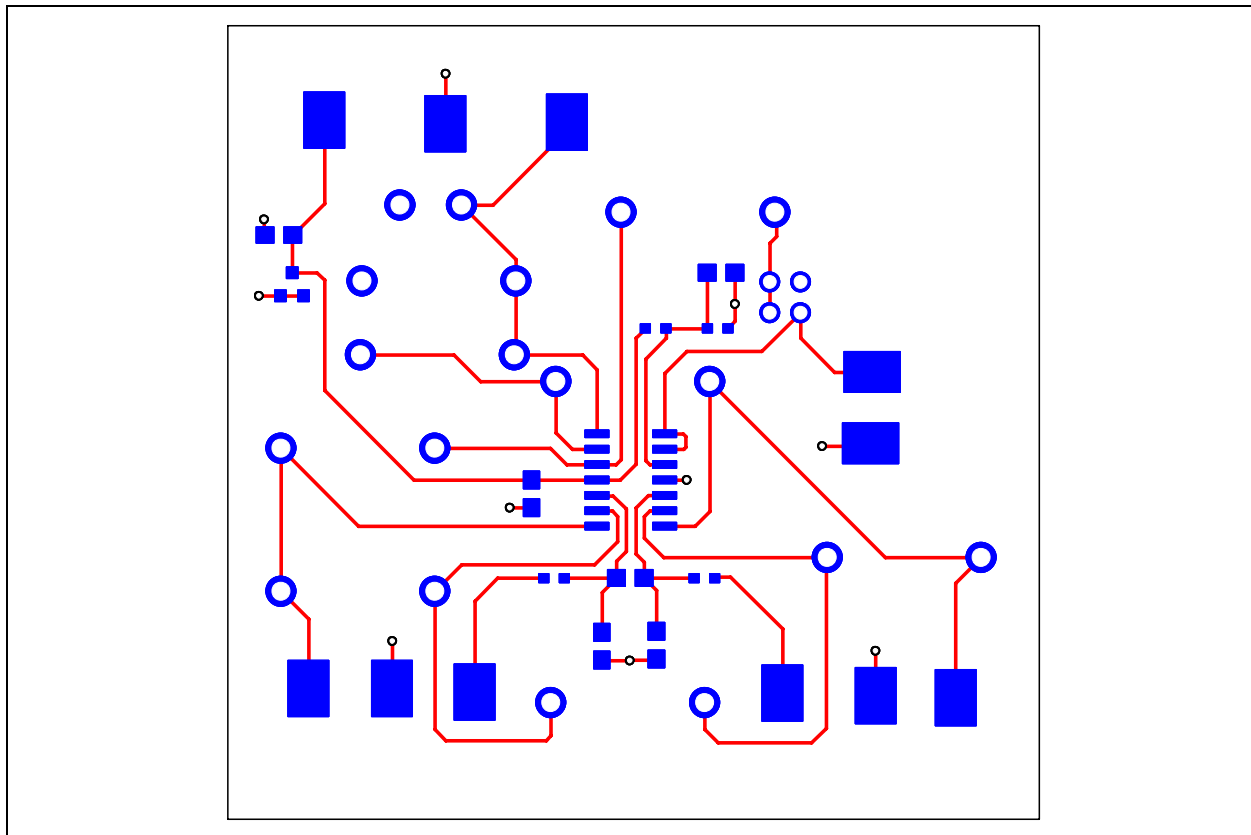

MCP6H04 Evaluation Board User's Guide

A.5 BOARD – BOTTOM METAL LAYER (BOTTOM VIEW)

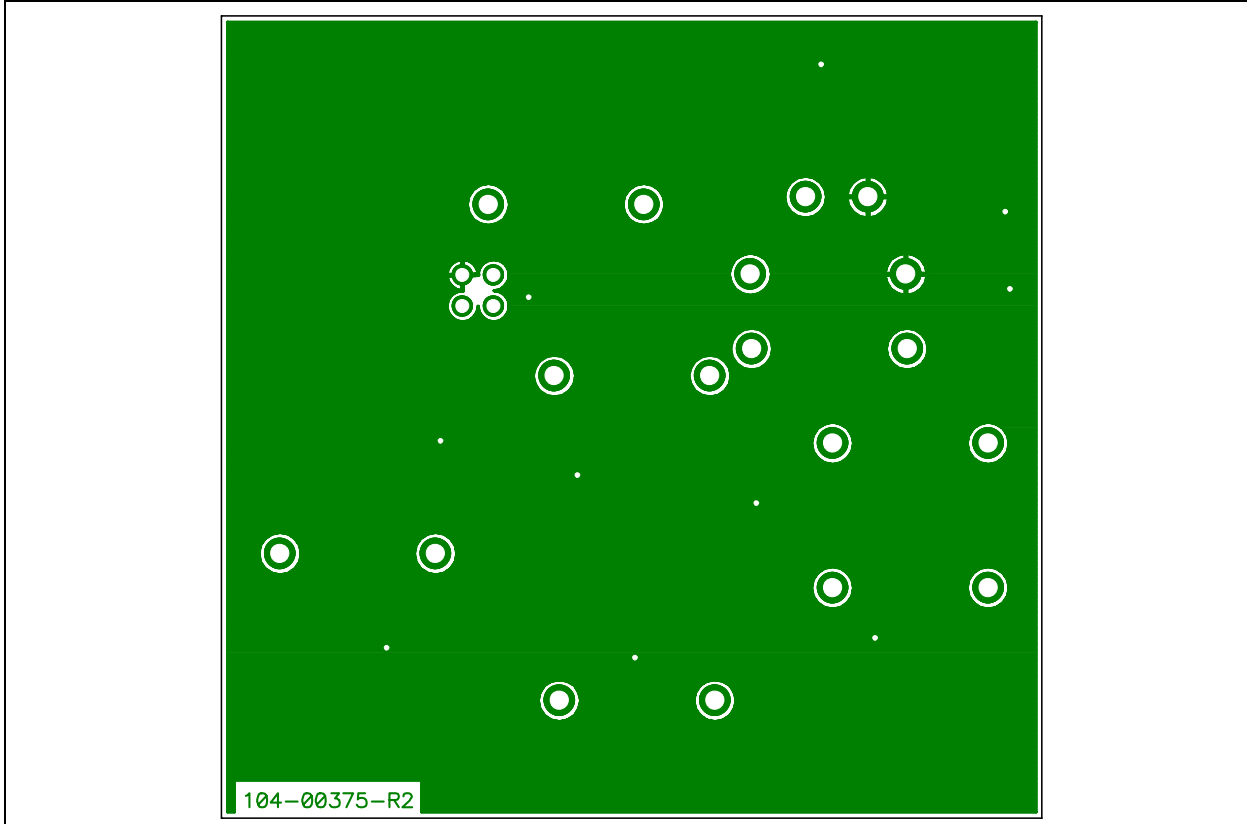

Appendix B. Bill of Materials

TABLE B-1: BILL OF MATERIALS (BOM)

Qty	Reference	Description	Manufacturer	Part Number
3	C1,C3,C4	CAPACITOR, 0805, X7R, 100V, 100NF	AVX Corporation	08051C104K4T2A
1	C2	CAPACITOR, 0805, X7R, 25V, 1UF	AVX Corporation	08053C105K4Z2A
2	C5,C6	CAPACITOR, 0805, X7R, 100V, 10NF	AVX Corporation	08051C103K4Z2A
1	DP1	ZENER, 16V, 350MW, SOT-23	Micro Commercial Components Corporation	BZX84C16-TP
1	JP1	CONN HEADR BRKWAY .100 02POS STR	TE Connectivity Ltd.	9-146258-0-02
1	PCB	RoHS Compliant Bare PCB, MCP6H04 Evaluation Board	Microchip Technology Inc.	104-00375
18	Pin Socket	PIN RECPT .015/.025 DIA 0667 SER	Mill-Max Mfg. Corporation	0667-0-15-01-30-27-10-0
2	R3,R4	RESISTOR, 100K, 0603 1% 0.1W	Vishay Intertechnology, Inc.	MCT06030C1003FP500
2	R5,R6	RESISTOR, 0603, 1K ,0.1%	TE Connectivity Ltd.	CPF0603B1K0E1
11	Test Points	PC TEST POINT COMPACT SMT	Keystone Electronics Corporation	5016
1	U1	MCP6H04	Microchip Technology Inc.	MCP6H04

Note 1: The components listed in this Bill of Materials are representative of the PCB assembly. The released BOM used in manufacturing uses all RoHS-compliant components.

TABLE B-2: BILL OF MATERIALS – ACCESSORIES BAG PARTS

Qty	Reference	Description	Manufacturer	Part Number
1	CL	CAPACITOR, DISC, 100V, 56PF	AVX Corporation	5KK560KOAAM
4	R1,R2,R1*, R2*	10K, 0.125W, 0.1%, 15PPM	Vishay Intertechnology, Inc.	PTF5610K000BXEB
1	RG	RESISTOR, 0.25W, 0.1%, 1K0	TE Connectivity Ltd.	H81K0BYA
2	RF, RF*	RES 50.0K OHM 1/4W 0.1% AXIAL	TE Connectivity Ltd.	H850KBCA
1	RL	0.5W 5% 10K	Vishay Intertechnology, Inc.	NFR25H0001002JR500

Note 1: The components listed in this Bill of Materials are representative of the loose components found in the accessories bag. The released BOM used in manufacturing uses all RoHS-compliant components.



MICROCHIP

Worldwide Sales and Service

AMERICAS

Corporate Office
2355 West Chandler Blvd.
Chandler, AZ 85224-6199
Tel: 480-792-7200
Fax: 480-792-7277
Technical Support:
<http://www.microchip.com/support>
Web Address:
www.microchip.com

Atlanta
Duluth, GA
Tel: 678-957-9614
Fax: 678-957-1455

Boston
Westborough, MA
Tel: 774-760-0087
Fax: 774-760-0088

Chicago
Itasca, IL
Tel: 630-285-0071
Fax: 630-285-0075

Cleveland
Independence, OH
Tel: 216-447-0464
Fax: 216-447-0643

Dallas
Addison, TX
Tel: 972-818-7423
Fax: 972-818-2924

Detroit
Farmington Hills, MI
Tel: 248-538-2250
Fax: 248-538-2260

Indianapolis
Noblesville, IN
Tel: 317-773-8323
Fax: 317-773-5453

Los Angeles
Mission Viejo, CA
Tel: 949-462-9523
Fax: 949-462-9608

Santa Clara
Santa Clara, CA
Tel: 408-961-6444
Fax: 408-961-6445

Toronto
Mississauga, Ontario,
Canada
Tel: 905-673-0699
Fax: 905-673-6509

ASIA/PACIFIC

Asia Pacific Office
Suites 3707-14, 37th Floor
Tower 6, The Gateway
Harbour City, Kowloon
Hong Kong
Tel: 852-2401-1200
Fax: 852-2401-3431

Australia - Sydney
Tel: 61-2-9868-6733
Fax: 61-2-9868-6755

China - Beijing
Tel: 86-10-8569-7000
Fax: 86-10-8528-2104

China - Chengdu
Tel: 86-28-8665-5511
Fax: 86-28-8665-7889

China - Chongqing
Tel: 86-23-8980-9588
Fax: 86-23-8980-9500

China - Hangzhou
Tel: 86-571-2819-3187
Fax: 86-571-2819-3189

China - Hong Kong SAR
Tel: 852-2401-1200
Fax: 852-2401-3431

China - Nanjing
Tel: 86-25-8473-2460
Fax: 86-25-8473-2470

China - Qingdao
Tel: 86-532-8502-7355
Fax: 86-532-8502-7205

China - Shanghai
Tel: 86-21-5407-5533
Fax: 86-21-5407-5066

China - Shenyang
Tel: 86-24-2334-2829
Fax: 86-24-2334-2393

China - Shenzhen
Tel: 86-755-8203-2660
Fax: 86-755-8203-1760

China - Wuhan
Tel: 86-27-5980-5300
Fax: 86-27-5980-5118

China - Xian
Tel: 86-29-8833-7252
Fax: 86-29-8833-7256

China - Xiamen
Tel: 86-592-2388138
Fax: 86-592-2388130

China - Zhuhai
Tel: 86-756-3210040
Fax: 86-756-3210049

ASIA/PACIFIC

India - Bangalore
Tel: 91-80-3090-4444
Fax: 91-80-3090-4123

India - New Delhi
Tel: 91-11-4160-8631
Fax: 91-11-4160-8632

India - Pune
Tel: 91-20-2566-1512
Fax: 91-20-2566-1513

Japan - Yokohama
Tel: 81-45-471- 6166
Fax: 81-45-471-6122

Korea - Daegu
Tel: 82-53-744-4301
Fax: 82-53-744-4302

Korea - Seoul
Tel: 82-2-554-7200
Fax: 82-2-558-5932 or
82-2-558-5934

Malaysia - Kuala Lumpur
Tel: 60-3-6201-9857
Fax: 60-3-6201-9859

Malaysia - Penang
Tel: 60-4-227-8870
Fax: 60-4-227-4068

Philippines - Manila
Tel: 63-2-634-9065
Fax: 63-2-634-9069

Singapore
Tel: 65-6334-8870
Fax: 65-6334-8850

Taiwan - Hsin Chu
Tel: 886-3-5778-366
Fax: 886-3-5770-955

Taiwan - Kaohsiung
Tel: 886-7-536-4818
Fax: 886-7-330-9305

Taiwan - Taipei
Tel: 886-2-2500-6610
Fax: 886-2-2508-0102

Thailand - Bangkok
Tel: 66-2-694-1351
Fax: 66-2-694-1350

EUROPE

Austria - Wels
Tel: 43-7242-2244-39
Fax: 43-7242-2244-393

Denmark - Copenhagen
Tel: 45-4450-2828
Fax: 45-4485-2829

France - Paris
Tel: 33-1-69-53-63-20
Fax: 33-1-69-30-90-79

Germany - Munich
Tel: 49-89-627-144-0
Fax: 49-89-627-144-44

Italy - Milan
Tel: 39-0331-742611
Fax: 39-0331-466781

Netherlands - Drunen
Tel: 31-416-690399
Fax: 31-416-690340

Spain - Madrid
Tel: 34-91-708-08-90
Fax: 34-91-708-08-91

UK - Wokingham
Tel: 44-118-921-5869
Fax: 44-118-921-5820

08/02/11



**Стандарт
Электрон
Связь**

Мы молодая и активно развивающаяся компания в области поставок электронных компонентов. Мы поставляем электронные компоненты отечественного и импортного производства напрямую от производителей и с крупнейших складов мира.

Благодаря сотрудничеству с мировыми поставщиками мы осуществляем комплексные и плановые поставки широчайшего спектра электронных компонентов.

Собственная эффективная логистика и склад в обеспечивает надежную поставку продукции в точно указанные сроки по всей России.

Мы осуществляем техническую поддержку нашим клиентам и предпродажную проверку качества продукции. На все поставляемые продукты мы предоставляем гарантию .

Осуществляем поставки продукции под контролем ВП МО РФ на предприятия военно-промышленного комплекса России , а также работаем в рамках 275 ФЗ с открытием отдельных счетов в уполномоченном банке. Система менеджмента качества компании соответствует требованиям ГОСТ ISO 9001.

Минимальные сроки поставки, гибкие цены, неограниченный ассортимент и индивидуальный подход к клиентам являются основой для выстраивания долгосрочного и эффективного сотрудничества с предприятиями радиоэлектронной промышленности, предприятиями ВПК и научно-исследовательскими институтами России.

С нами вы становитесь еще успешнее!

Наши контакты:

Телефон: +7 812 627 14 35

Электронная почта: sales@st-electron.ru

Адрес: 198099, Санкт-Петербург,
Промышленная ул, дом № 19, литера Н,
помещение 100-Н Офис 331