

SST-10-FR

Far Red LED

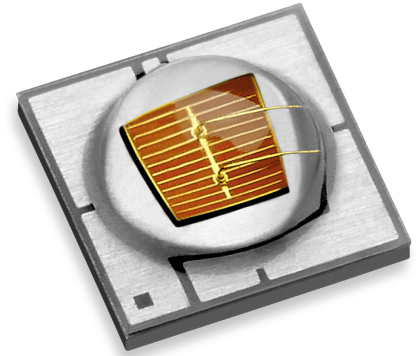

Table of Contents

| | |
|---|----|
| SST-10 Binning Structure . . . | 2 |
| Product Shipping & Labeling Information | 3 |
| Optical and Electrical Characteristics | 4 |
| B130 - Mech. Dimensions . . . | 6 |
| B130 - Tape and Reel | 7 |
| B90 - Mech. Dimensions . . . | 8 |
| B90 - Tape and Reel | 9 |
| Soldering Profile | 10 |
| Precautions for Use | 11 |
| History of Changes | 12 |

Features:

- High Power Far Red LED with Peak Wavelength of 730nm
- Wall-Plug Efficiency: typ. 42% @350mA
- 90 or 130° viewing angle at 50% Iv
- Low Thermal Resistance
- Built-in ESD Protection
- RoHS and REACH compliant
- Companion LEDs at 450nm and 660nm

Applications

- Horticulture / Growlights
- Machine Vision
- Surveillance Systems / CCTV

SST-10 Binning Structure

SST-10 Far Red LEDs are tested for luminous flux and chromaticity at a drive current of 350mA - 20ms single pulse and placed into one of the following luminous flux (FF) and chromaticity (WW) bins:

Flux Bins - Test condition=350mA, 25°C, 20ms pulse

| Flux Bin (FF) | Minimum Flux (mW) | Maximum Flux (mW) |
|---------------|-------------------|-------------------|
| G | 270 | 310 |
| H | 310 | 350 |
| J | 350 | 390 |

Wavelength Bins - Test condition=350mA, 25°C, 20ms pulse

| Chromaticity Bin (WW) | Minimum Wavelength (nm) | Maximum Wavelength (nm) |
|-----------------------|-------------------------|-------------------------|
| F1 | 720 | 725 |
| F2 | 725 | 730 |
| F3 | 730 | 735 |
| F4 | 735 | 740 |
| F5 | 740 | 745 |
| F6 | 745 | 750 |

*Note: Luminus maintains a +/- 6% tolerance on flux measurements.

Ordering Information

| Products | Ordering Part Number | Description |
|----------------|----------------------|--|
| SST-10-FR-B90 | SST-10-FR-B90-xx123 | High Power 1-mm ² Far Red LED in a 3535 surface mount package and a 90-degree lens |
| SST-10-FR-B130 | SST-10-FR-B130-xx123 | High Power 1-mm ² Far Red LED in a 3535 surface mount package and a 130-degree lens |

Part Number Nomenclature

SST — 10 — <A> — <B###> — <FF###>

| Product Family | LED Emission Area | Color | Package Configuration | Bin kit |
|----------------------------|-------------------------|----------------------------|--|---|
| SST: Surface Mount Package | 10: 1.0 mm ² | <A>: Color FR = Far Red | B90: 90-degree lens B130: 130-degree lens | Flux and Chromaticity bin kit code - See available ordering codes below |

SST-10 Bin Kit Order Codes

The following table describes the bin kit ordering codes available for the SST-10 Far Red LEDs. Each bin kit specifies a minimum flux as well as specific chromaticity bins allowed. Please note that within each kit a maximum flux is not specified and as a result Luminus may ship any part meeting or exceeding the minimum flux specification. Shipments will always meet the listed chromaticity bins. For information on ordering bin kits not listed below, please contact Luminus.

SST-10 Far Red Bin Kit Order Codes

| Color | Luminous Flux | | Chromaticity Bins | Kit Number |
|---------|-------------------|-----------|-------------------|------------|
| | Bin Kit Flux Code | Min. Flux | | |
| Far Red | G | 270 | F1,F2,F3,F4,F5,F6 | G730 |

Product Shipping & Labeling Information

All SST-10 products are packaged and labeled with their respective bin as outlined in the tables on pages 2 & 3. Each reel will only contain one bin.

SST-10 Far Red

SST — 10 — FR — BXXX — FFWW

| Product Family | LED Emission Area | Color | Package Configuration | Bin kit |
|----------------------------|-------------------------|-------|--|--|
| SST: Surface Mount Package | 10: 1.0 mm ² | Color | B90: 90-degree lens B130: 130-degree lens | Flux and Chromaticity bin kit code as outlined above |

Optical and Electrical Characteristics

Optical and Electrical Characteristics at 350mA¹

| Parameter | Symbol | Minimum | Typical | Maximum | Unit |
|---------------------------------|-----------------------|---------|-----------|---------|---------|
| Forward Current ² | I_f | | 350 | 1,500 | mA |
| Output Power | Φ_r | | 310 | | mW |
| Forward Voltage | V_f | 1.8 | 2.1 | 2.6 | V |
| Wall-Plug Efficiency | WPE | | 42 | | % |
| Viewing Angle | $2 \varnothing_{1/2}$ | | 90 or 130 | | degrees |
| Peak Wavelength | λ_p | 720 | 730 | 750 | nm |
| FWHM | $\Delta\lambda_{1/2}$ | 29 | 31 | 33 | nm |
| Thermal Resistance (Electrical) | R_{TH} | | 5.3 | | °C/W |

Absolute Maximum Ratings²

| Parameter | Symbol | Rating | Unit |
|--------------------------------|------------------|-------------------|------|
| Forward Current ^{3,4} | I | 1.5 | A |
| Power Dissipation | P _D | 3.0 | W |
| Reverse Voltage | V _R | 5 | V |
| Storage Temperature | T _{STG} | -40~100 | °C |
| Junction Temperature | T _J | 115 °C | °C |
| Soldering Temperature | T _{SLD} | JEDEC 020, 260 °C | |
| ESD Sensitivity (HBM) | V _B | 6000 | V |

Note 1: Ratings are based on operation at a constant junction temperature of $T_j = 25^\circ\text{C}$.

Note 2: To prevent damage, please refer to operating conditions and derating curves for appropriate maximum operating conditions

Note 3: Maximum operating case temperature combined with maximum drive current defines the total maximum operating condition for the device. To prevent damage, please follow derating curves for all operating conditions.

Note 4: Luminus SST-10-Deep Red LEDs are designed for operation up to an absolute maximum forward drive current as specified above. Product lifetime data is specified at typical forward drive currents. Sustained operation at absolute maximum currents will result in a reduction of device lifetime compared to typical forward drive currents. Actual device lifetimes will also depend on junction temperature. Refer to the current vs. junction temperature derating curves for further information. In pulsed operation, rise time from 10-90% of forward current should be larger than 0.5 microseconds.

Note 5: Caution must be taken not to stare at the light emitted from these LEDs. Under special circumstances, the high intensity could damage the eye.

Optical and Electrical Characteristics

Relative Output Flux vs. Forward Current

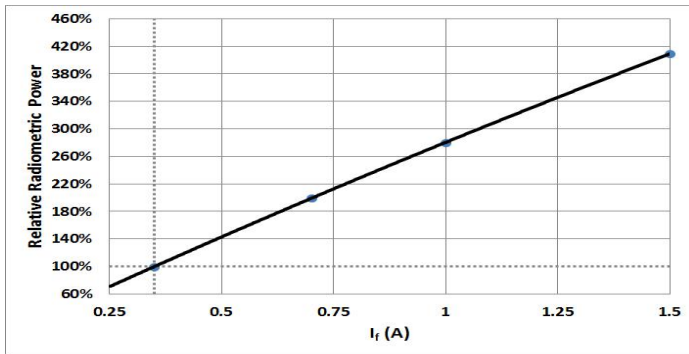

Forward Current vs. Forward Voltage

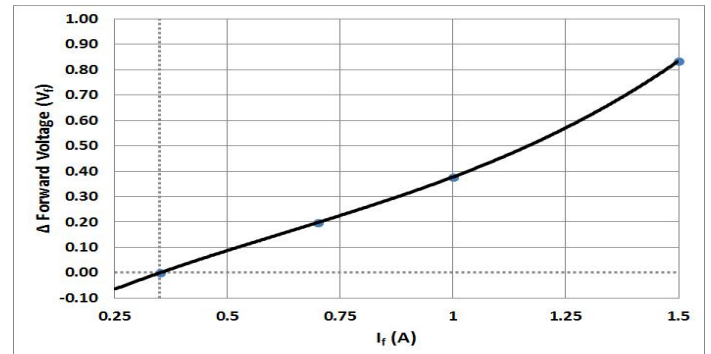

Relative Output Flux vs. Ambient Temperature

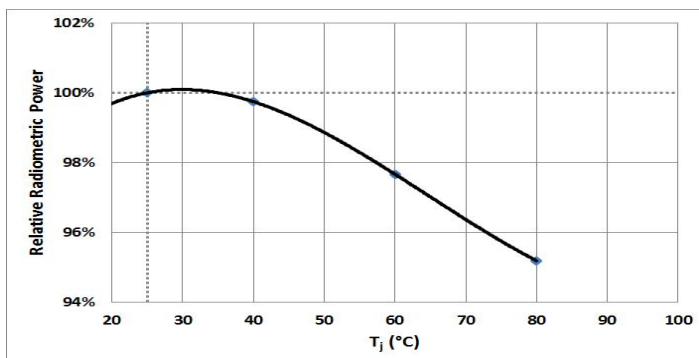

Typical Spectra

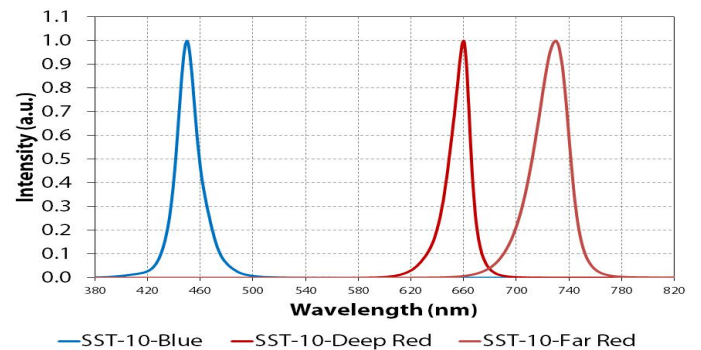

Typical Polar Radiation Plot - B130

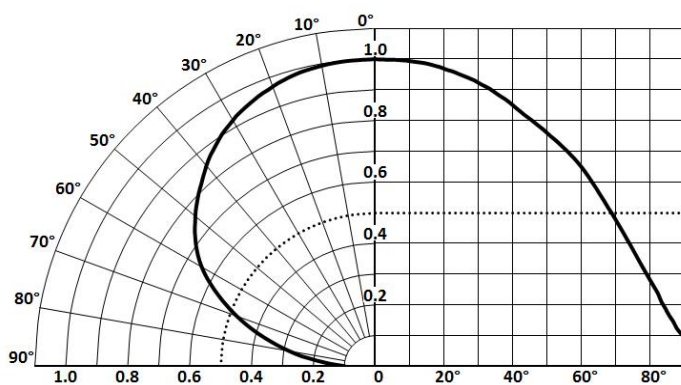

Typical Polar Radiation Plot - B90

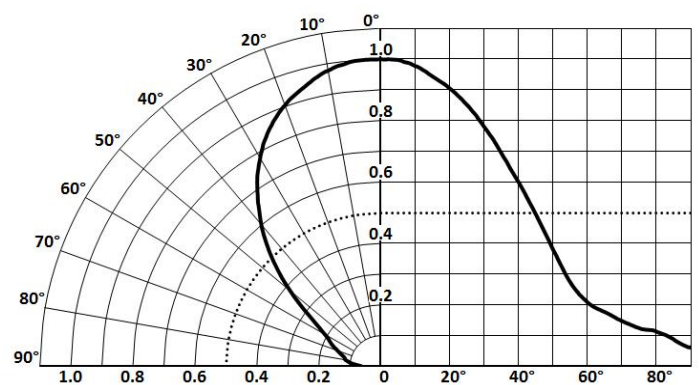

Mechanical Dimensions - B130 Package

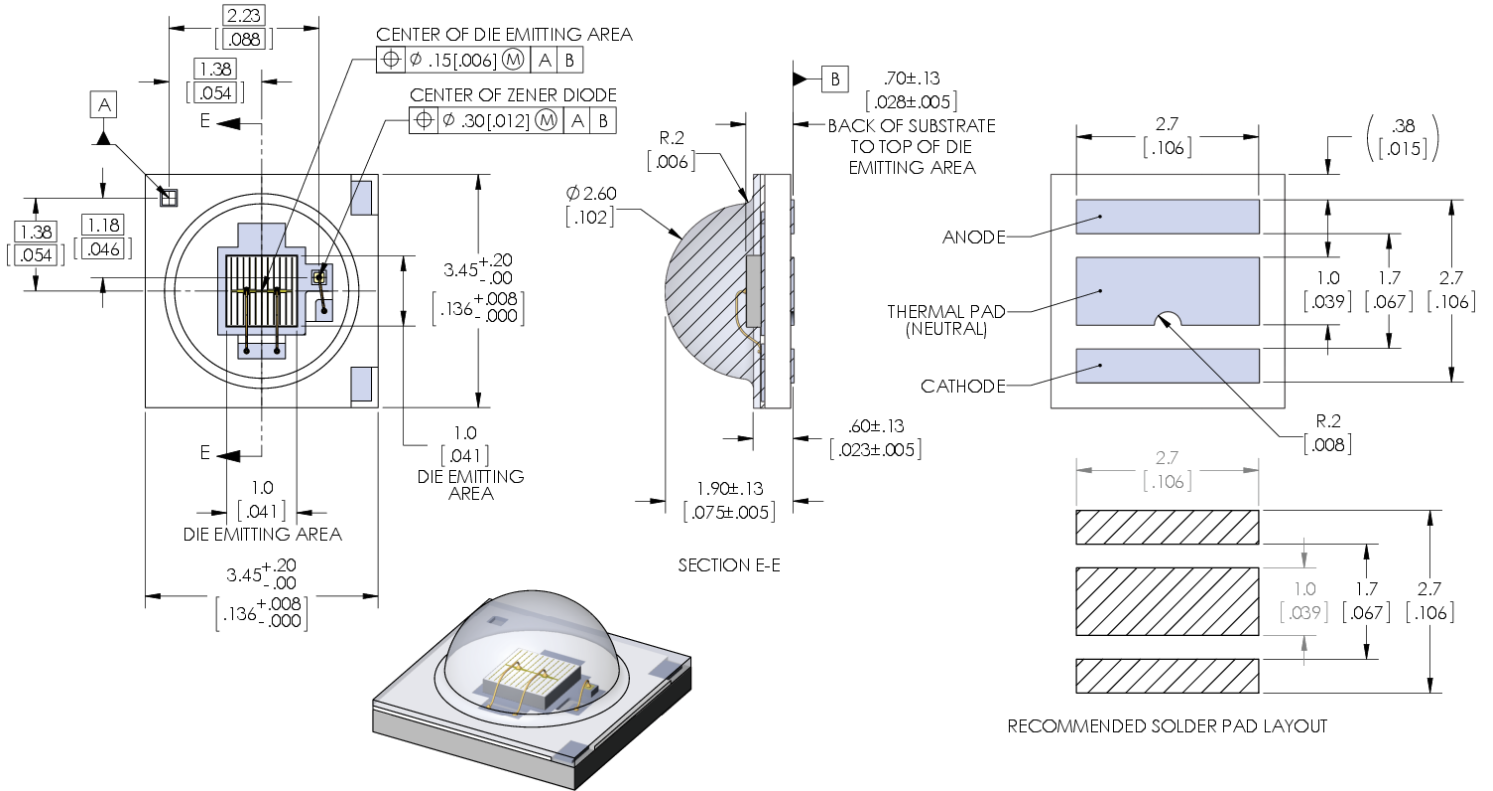

Tape and Reel - B130 Package

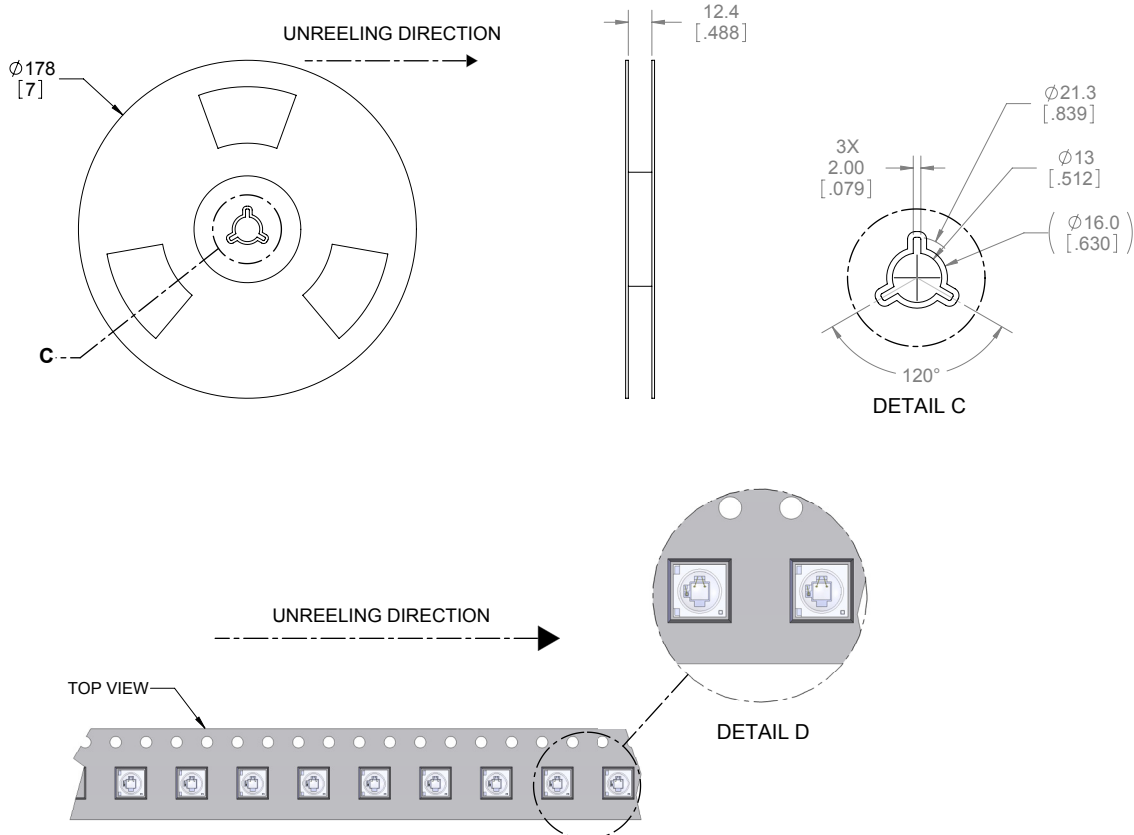
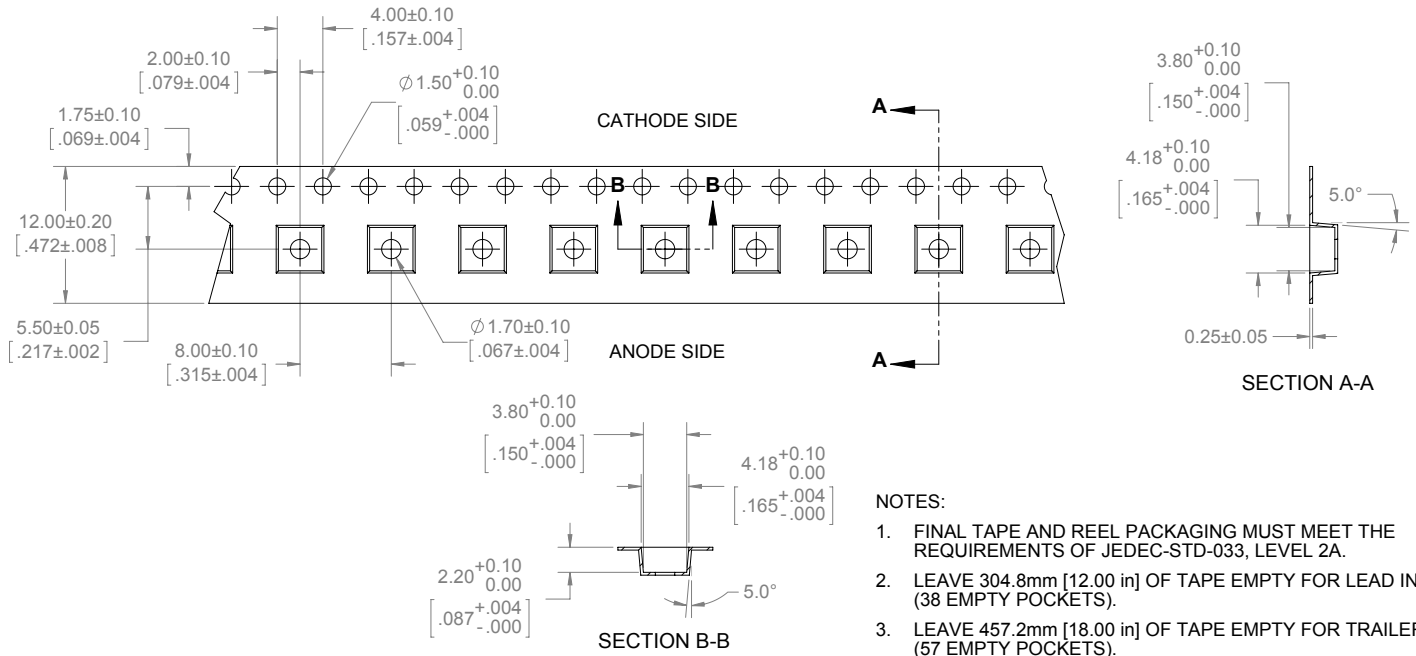

Mechanical Dimensions - B90 Package

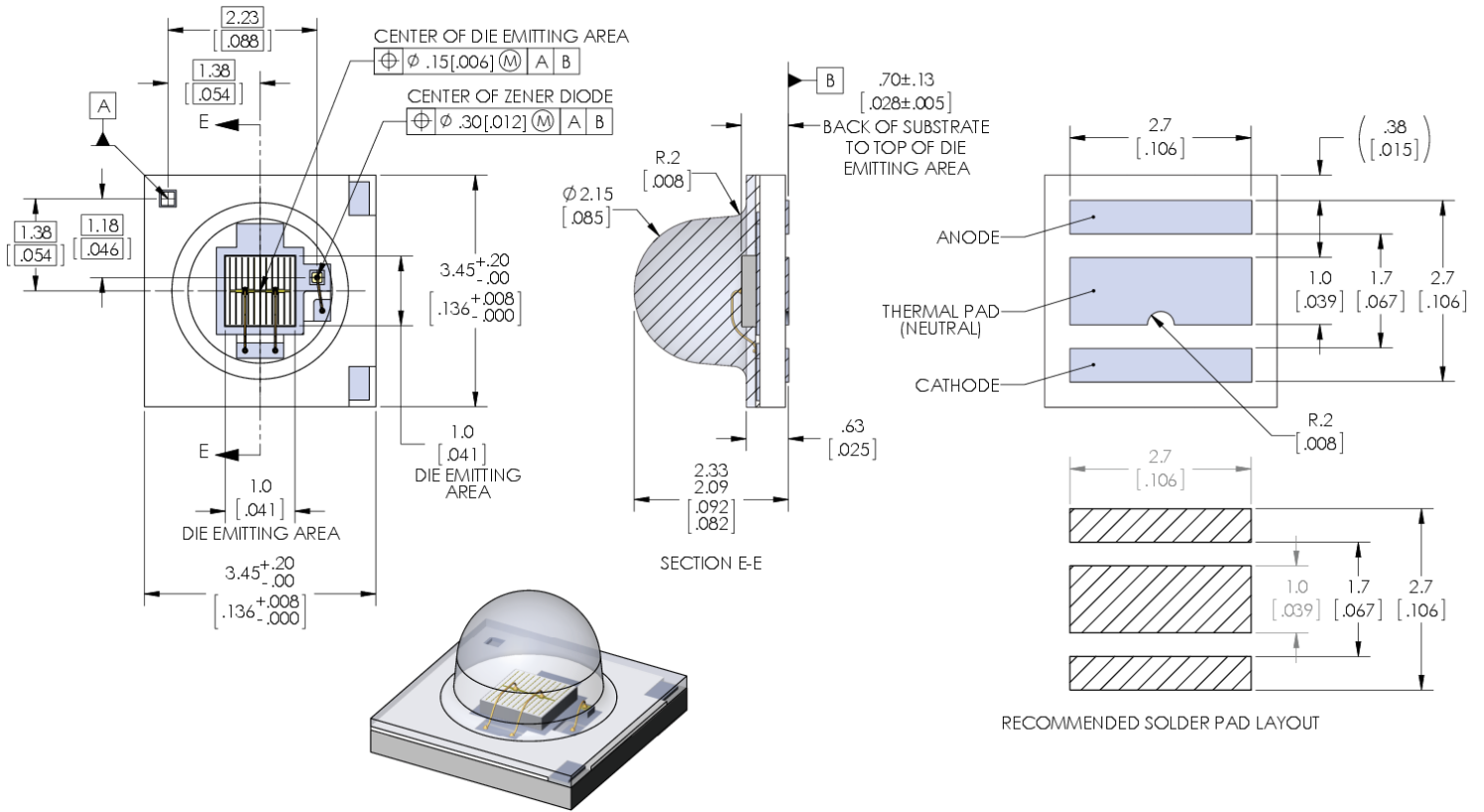

Tape and Reel - B90 Package

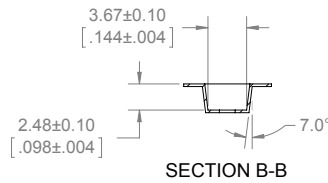
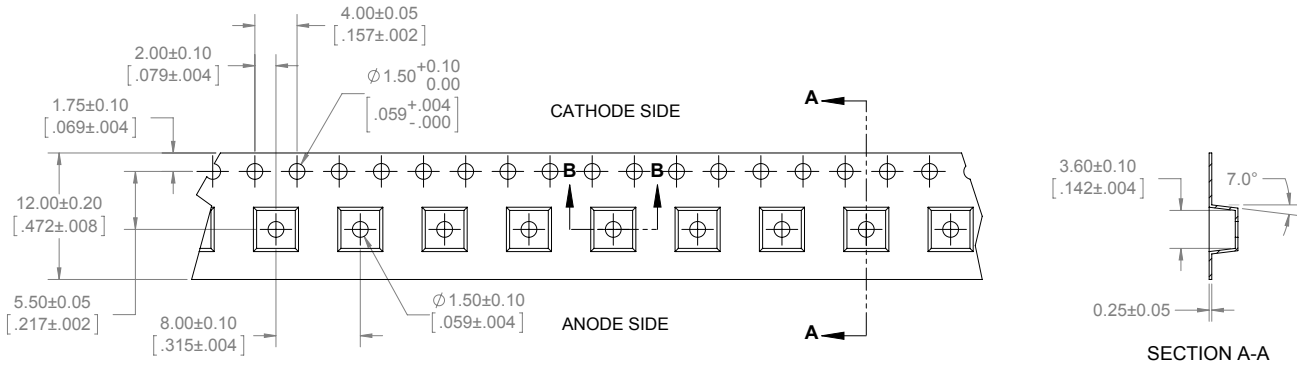

NOTES:

1. FINAL TAPE AND REEL PACKAGING MUST MEET THE REQUIREMENTS OF JEDEC-STD-033, LEVEL 2A.
2. LEAVE 304.8mm [12.00 in] OF TAPE EMPTY FOR LEAD IN (38 EMPTY POCKETS).
3. LEAVE 457.2mm [18.00 in] OF TAPE EMPTY FOR TRAILER (57 EMPTY POCKETS).
4. MUST COMPLY TO EIA-481-C-2003

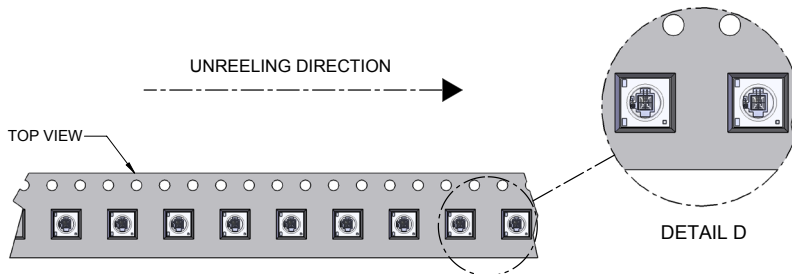
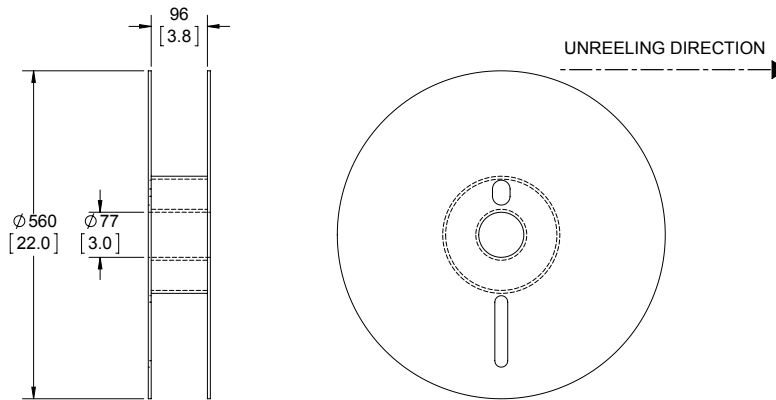

Soldering Profile

| Profile Feature | Sn-Pb Eutectic Assembly | Pb-Free Assembly |
|--|-------------------------|------------------|
| Preheat & Soak | 100 °C | 150 °C |
| Temperature min (T _{smin}) | 150 °C | 200 °C |
| Temperature max (T _{smax}) | 60-120 seconds | 60-120 seconds |
| Time (T _{smin} to T _{smax}) (t _s) | | |
| Average ramp-up rate (T _{smax} to T _p) | 3 °C/second max | 3 °C/second max |
| Liquidous temperature (T _L) | 183 °C | 217 °C |
| Time at liquidous (t _L) | 60-150 seconds | 60-150 seconds |
| Peak package body temperature (T _p)* | 230 °C ~235 °C | 255 °C ~260 °C |
| Classification temperature (T _c) | 235 °C | 260 °C |
| Time (t _p) within 5 °C of the specified classification temperature (T _c) | 20 seconds | 30 seconds |
| Average ramp-down rate (T _p to T _{smax}) | 6 °C/second max | 6 °C/second max |
| Time 25 °C to peak temperature | 6 minutes max | 8 minutes max |

* Tolerance for peak profile temperature(T_p) is defined as a supplier minimum and a user maximum.

** Tolerance for time at peak profile temperature(t_p) is defined as a supplier minimum and a user maximum.



Precautions for Use

Storage:

1. Before opening the package

The LEDs should be kept at a temperature lower than 40° C and relative humidity lower than 90%. The LEDs should be used within a year. When storing the LEDs, moisture proof package with absorbent material (silica gel) is recommended.

2. After opening the package

The LEDs should be kept at temperature lower than 30° C and relative humidity lower than 60%. The LEDs should be soldered within 168 hours (7days) after opening the moisture proof package.

If unused LEDs remain, they should be stored in moisture proof packages, such as sealed containers with moisture proof package within absorbent material (silica gel). It is also recommended to return the unused LEDs to the original moisture proof package and to seal the moisture proof package again.

If the moisture absorbent material (silica gel) vapors or expires the expiration date, baking treatment should be performed by using the following conditions : 60 °C for 20 hours.

The LEDs electrode and leadframe comprise a silver plated copper alloy. The silver surface may be affected by environments. Please avoid conditions which may cause the LEDs to corrode or discolor. The corrosion or discoloration might lower solderability or affect optical characteristics.

Please avoid rapid transition in ambient temperature, especially in high humidity environments where condensation can occur.

Static Electricity:

1. The products are sensitive to static electricity, and care should be taken when handling them.

2. Static electricity or surge voltage will damage the LEDs. It is recommended to wear a anti-electrostatic wristband or anti-electrostatic gloves when handling the LEDs.

3. All devices, equipment and machinery must be properly grounded. It is recommended that measures be taken against surge voltage to the equipment that mounts the LEDs.

History of Changes

| Rev | | Description of Change |
|-----|------------|--|
| 01 | 09/17/2015 | Initial Release - Preliminary Specifications |
| 02 | 10/13/2015 | Updated solder pad layout and added 80-degree lens option |
| 03 | 04/26/2016 | Updated binning and angular distribution data. Added 90-degree tape & reel |



Стандарт Электрон Связь

Мы молодая и активно развивающаяся компания в области поставок электронных компонентов. Мы поставляем электронные компоненты отечественного и импортного производства напрямую от производителей и с крупнейших складов мира.

Благодаря сотрудничеству с мировыми поставщиками мы осуществляем комплексные и плановые поставки широчайшего спектра электронных компонентов.

Собственная эффективная логистика и склад в обеспечивает надежную поставку продукции в точно указанные сроки по всей России.

Мы осуществляем техническую поддержку нашим клиентам и предпродажную проверку качества продукции. На все поставляемые продукты мы предоставляем гарантию .

Осуществляем поставки продукции под контролем ВП МО РФ на предприятия военно-промышленного комплекса России , а также работаем в рамках 275 ФЗ с открытием отдельных счетов в уполномоченном банке. Система менеджмента качества компании соответствует требованиям ГОСТ ISO 9001.

Минимальные сроки поставки, гибкие цены, неограниченный ассортимент и индивидуальный подход к клиентам являются основой для выстраивания долгосрочного и эффективного сотрудничества с предприятиями радиоэлектронной промышленности, предприятиями ВПК и научно-исследовательскими институтами России.

С нами вы становитесь еще успешнее!

Наши контакты:

Телефон: +7 812 627 14 35

Электронная почта: sales@st-electron.ru

Адрес: 198099, Санкт-Петербург,
Промышленная ул, дом № 19, литера Н,
помещение 100-Н Офис 331