

# NIS54xxGEVB

## NIS54xx Evaluation Board User's Manual

*eFuse test board with multiple subcircuits for evaluation of overvoltage protection, overcurrent protection, controlled slew rate, and thermal shutdown features*



**ON Semiconductor®**

---

### Eval Board User's Manual

#### Introduction

Engineers developing a varied array of systems utilize sophisticated integrated eFuses to serve a variety of purposes. They may be found connected to 3.3, 5, 12, and 24 V power rails and have many interesting features.

The primary features of eFuses are:

- Current limiting (adjustable on a few models)
- Overvoltage clamping (except on NIV6124)
- Undervoltage lockout
- Enable/Fault control
- Thermal shutdown
- Controlled slew rate
- Reverse current protection on some devices such as NIS6xxx

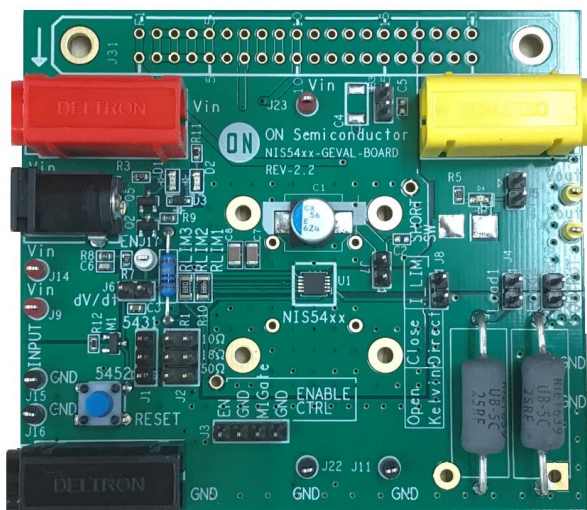
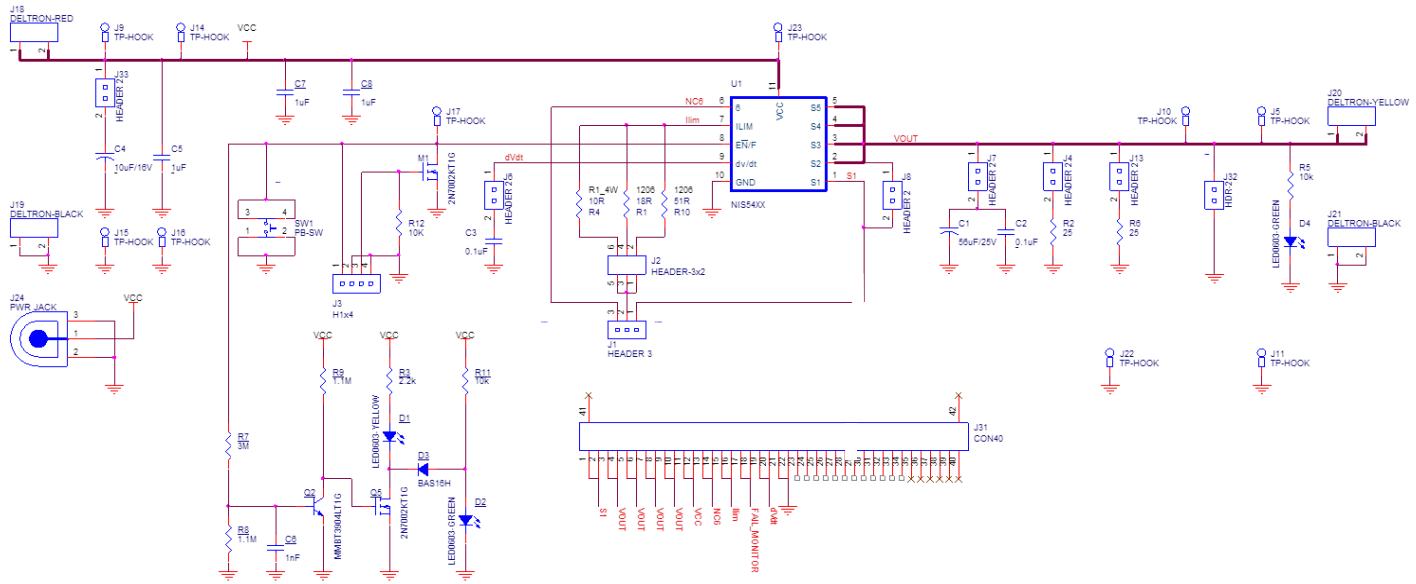

**Figure 1: The NIS545xGEVB evaluation board**

This evaluation board has many features which make it simple to observe the functionality and performance of the new NIS54xx line of eFuses. This manual documents the use of this board with the NIS5452 latching eFuse. The properties of the NIS54xx evaluation board include:

- Multiple connectors available for all eFuse pins (VCC, GND, enable, ILIM, dv/dt)
- Input and output capacitors
- A pushbutton switch and a MOSFET to connect the enable pin to GND or float it as needed
- Green and yellow LEDs to indicate whether the eFuse enable pin voltage is high (device enabled) or low (device disabled)
- Three current limit resistor options available directly on the board (10, 18, 50  $\Omega$ )
- Two load resistors (25  $\Omega$  each) on the board
- A jumper to short circuit the load and a green indicator LED which is on when the output voltage is high during normal operation
- Kelvin or direct sensing options via the jumper between pins 1 and 2 for NIS5452
- Edge connector option to use the device on a DUT card.

# NIS54xxGEVB



**Figure 2: Schematic for the evaluation board.**

The NIS54xx eval board can be used to test NIS5431, 3.3 V series of devices and NIS545x, 5 V series of devices. Make sure the jumper J1 is in “5452” position for the NIS5452 and in the “5431” position for the NIS5431. Otherwise the manual applies the same to both devices with the exception of the voltage levels being either 3.3 or 5.

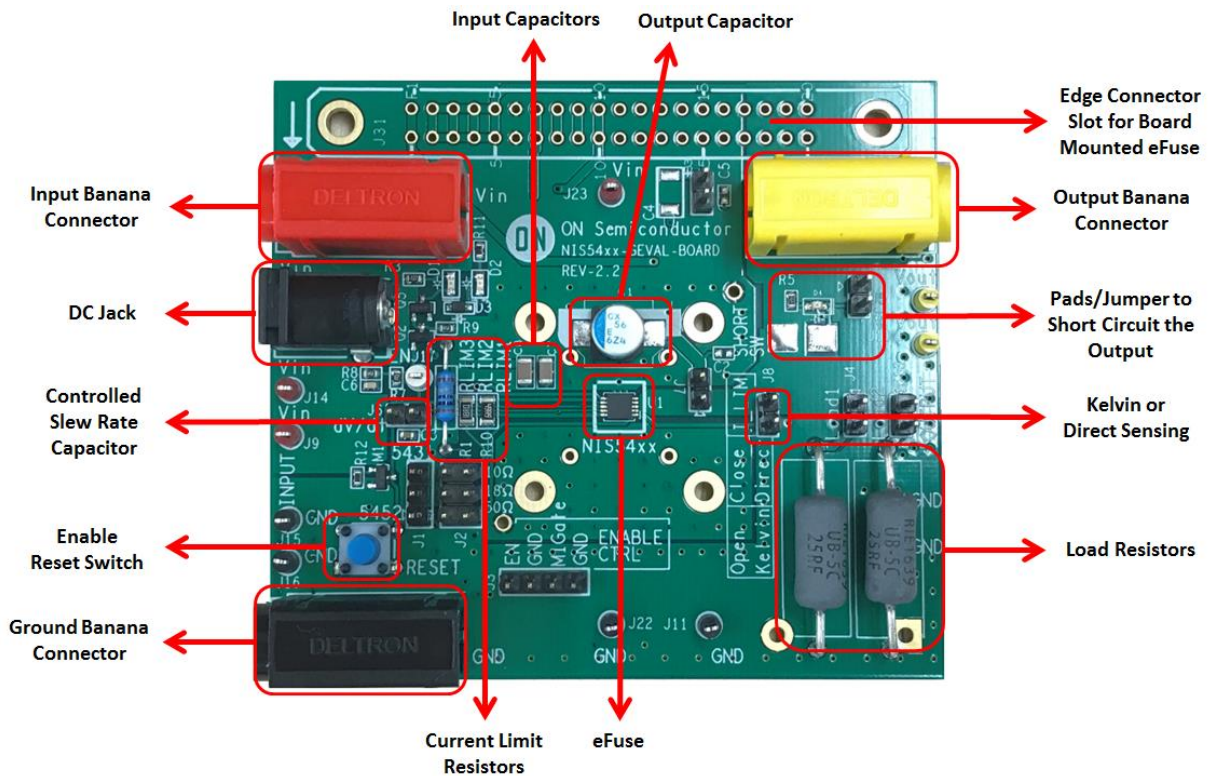

**Figure 3: Features of the evaluation board**

## NIS54xxGEVB

### NIS545x Overvoltage Protection

Connect the eFuse to a variable DC power supply. Place jumpers J1 (5452) and J2 (10  $\Omega$ ) and connect a 5.0 ohm load (can be an external power resistor or an electronic load). Use jumper J7 to connect the 56  $\mu\text{F}$  capacitor to the output. Turn the power supply from 5 to 10 V to observe the overvoltage protection circuit in operation. The input voltage will rise, but the output voltage will be maintained at the Vclamp level of about 6 V. After conducting 1.2 A with a voltage drop of 4 V, the eFuse will reach its thermal shutdown point and latch off. The green indicator LEDs will turn off and the yellow “fault” indicator LED will be on.

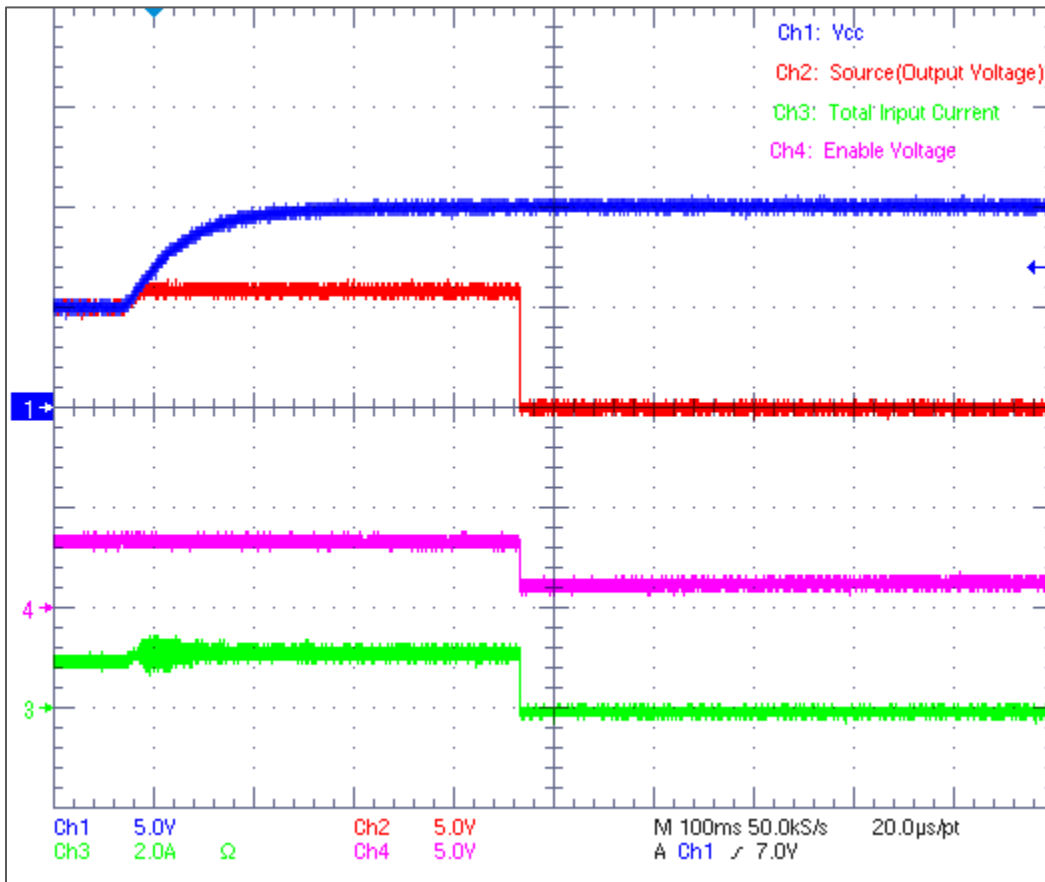
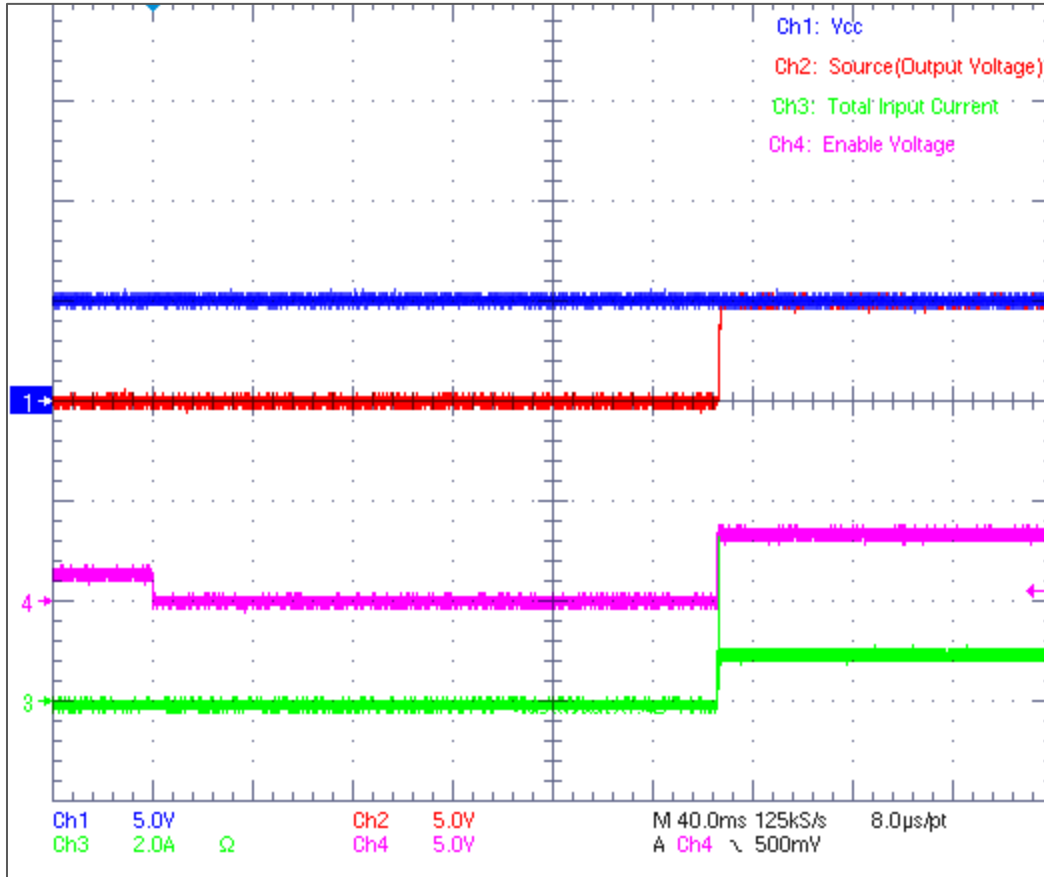

Figure 10: In this test, the input voltage (blue trace) is brought to 10 V. The output voltage (red trace) is clamped at about 6 V. After some time the device enters thermal shutdown with enable voltage (pink trace) falling to 1.4 V. The ringing on the output current (green trace) during Vclamp is due to the high output capacitance. This capacitance is required for the stability of the eFuse during the short circuit condition when long cables are running between the eFuse and the load.

# NIS54xxGEVB

## NIS545x Reset from Thermal Shutdown

To demonstrate reset from thermal shutdown start with the eFuse in thermal shutdown from overvoltage test as described in the previous section. Once the eFuse reaches thermal shutdown the enable pin falls to 1.4 V. Return the power supply to 5 V and press and release the blue switch to reset the eFuse. The blue switch momentarily connects the Enable pin to GND and releases it.



**Figure 11:** This test shows how the enable pin is used to reset the device after a thermal shutdown event. After pressing the blue switch the enable pin falls to 0 V and then comes to about 3.3 V after releasing the blue button. At that point the eFuse turns on. The initial spike on the current during the eFuse start up is the inrush current due to the output capacitor.

# NIS54xxGEVB

## NIS545x Overcurrent Protection

Continue with jumpers J1 (545x) and J2 (10  $\Omega$ ) and 5.0 ohm load connected. Make sure jumper J7 is in place which connects the eFuse output to 56  $\mu\text{F}$  capacitor. With VCC set to 5 V, short the output of the eFuse to GND using jumper J32. A power supply capable of supplying more than 3 A is recommended. The eFuse recognizes the fault and responds to the short circuit within 10  $\mu\text{s}$ . The current will be limited to the short circuit current limit level. After some time the device will enter thermal shutdown due to the high current and voltage between VCC and source (output voltage) pins.

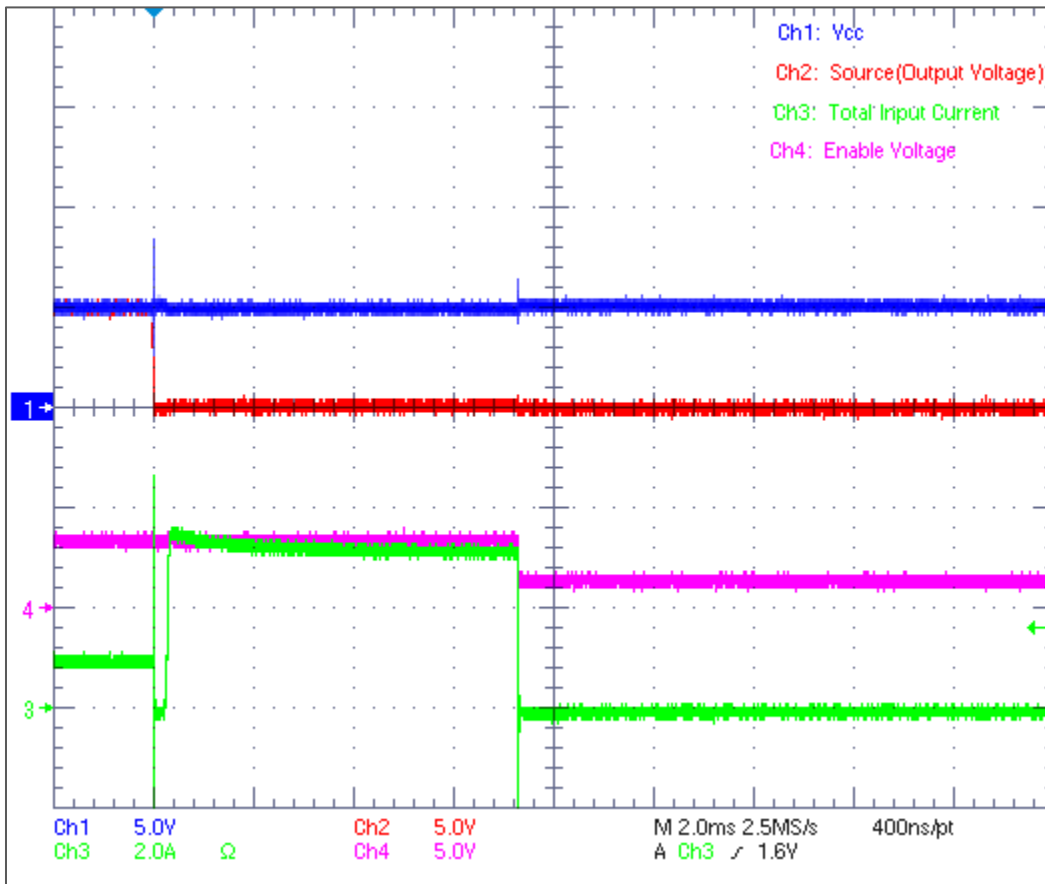
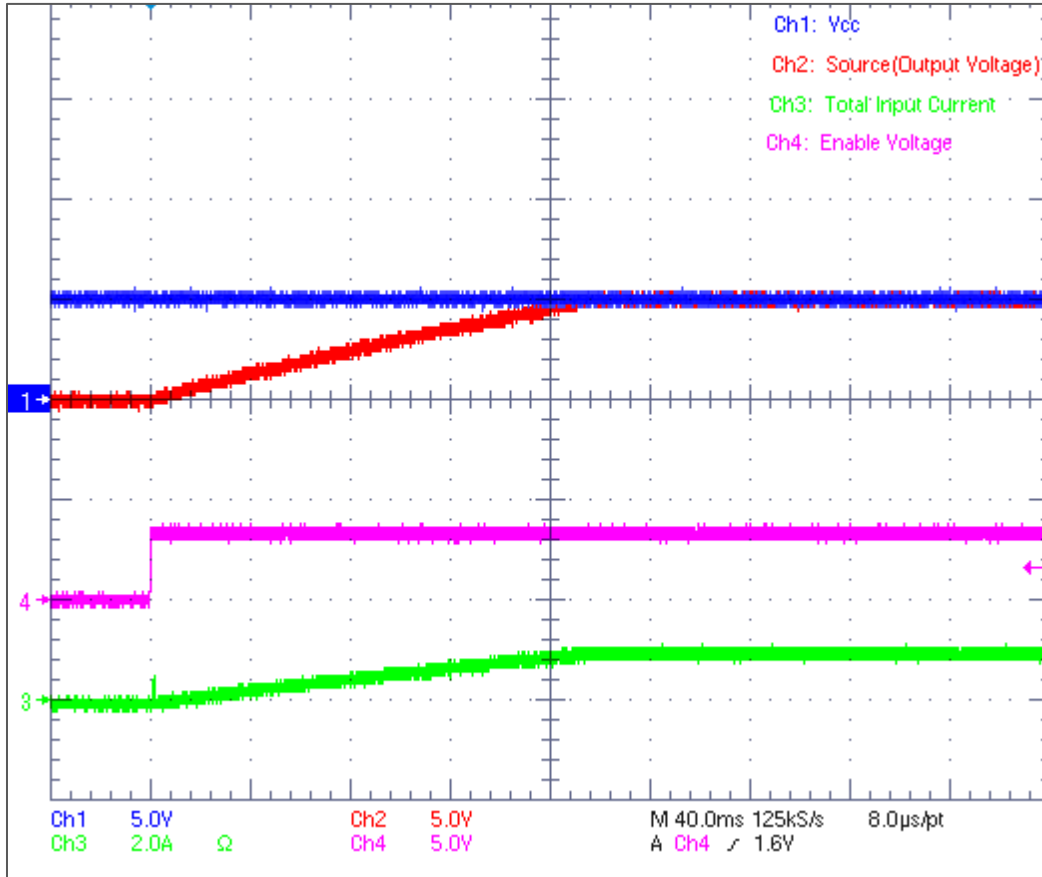

Figure 12: This is a demonstration of the current limiting circuit. The eFuse starts into a load normally and then the load is shorted to GND. The eFuse responds quickly to the short circuit event and begins conducting at the short circuit current limit. Once the eFuse heats up, it enters thermal shutdown and latches off. The output capacitor stabilizes the output current in the case of long cables running from eFuse output to the load.

# NIS54xxGEVB

## NIS545x Controlled slew rate

Continue with jumpers J1 (545x) and J2 (10  $\Omega$ ) and 5.0 ohm load connected. Perform this test with and without the J6 jumper in place to observe how the duration of the controlled slew rate changes. When J6 is in place, the slew rate will be longer because a capacitor is connected between the dv/dt pin and GND. With VCC set to 5 V, press and release the blue switch to see the eFuse turn on with a controlled output voltage slew rate.



**Figure 13:** This is a demonstration of the controlled slew rate circuit with J6 in place. Without J6 in place, the slew rate will be fast.

# NIS54xxGEVB

## NIS545x Hot Plug Power On

Use jumpers J1 (545x), J2 (10  $\Omega$ ) and J6 and connect a 5.0 ohm load. Manually take the 5 V power cable and plug it into the demo board. Observe that the eFuse turns on with no issue and the output voltage rises in a controlled fashion.

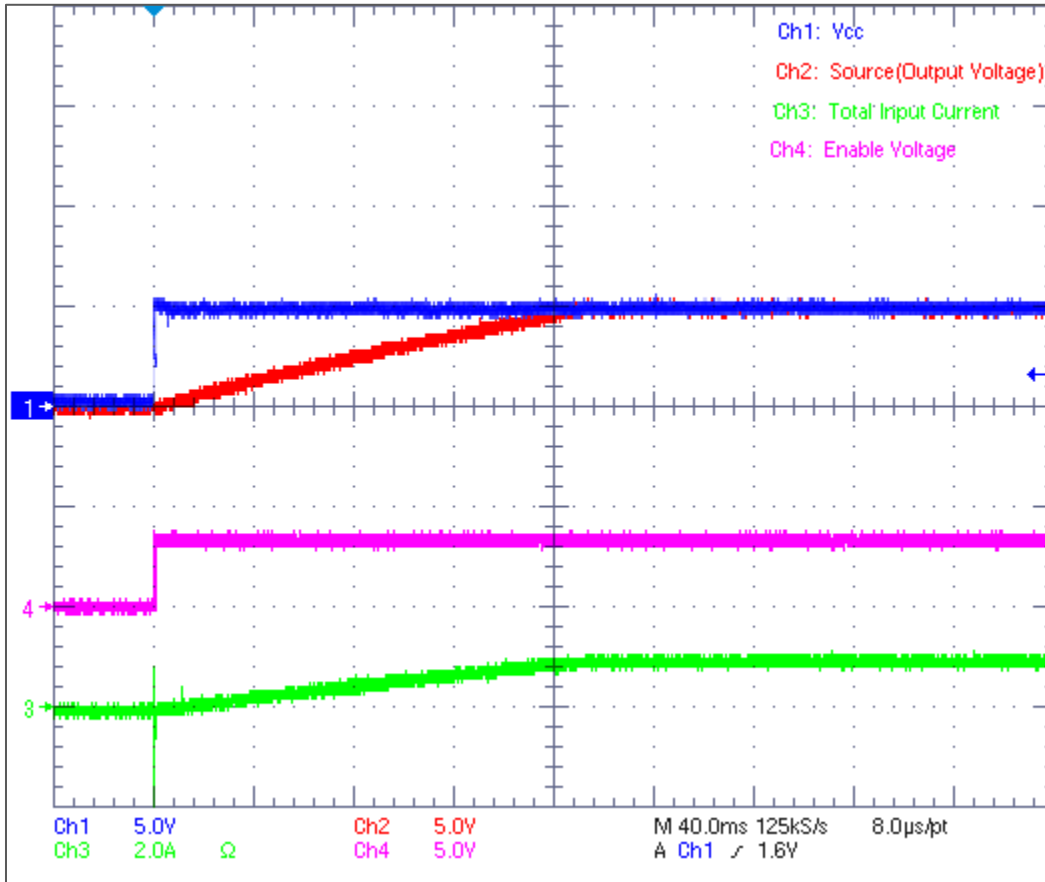
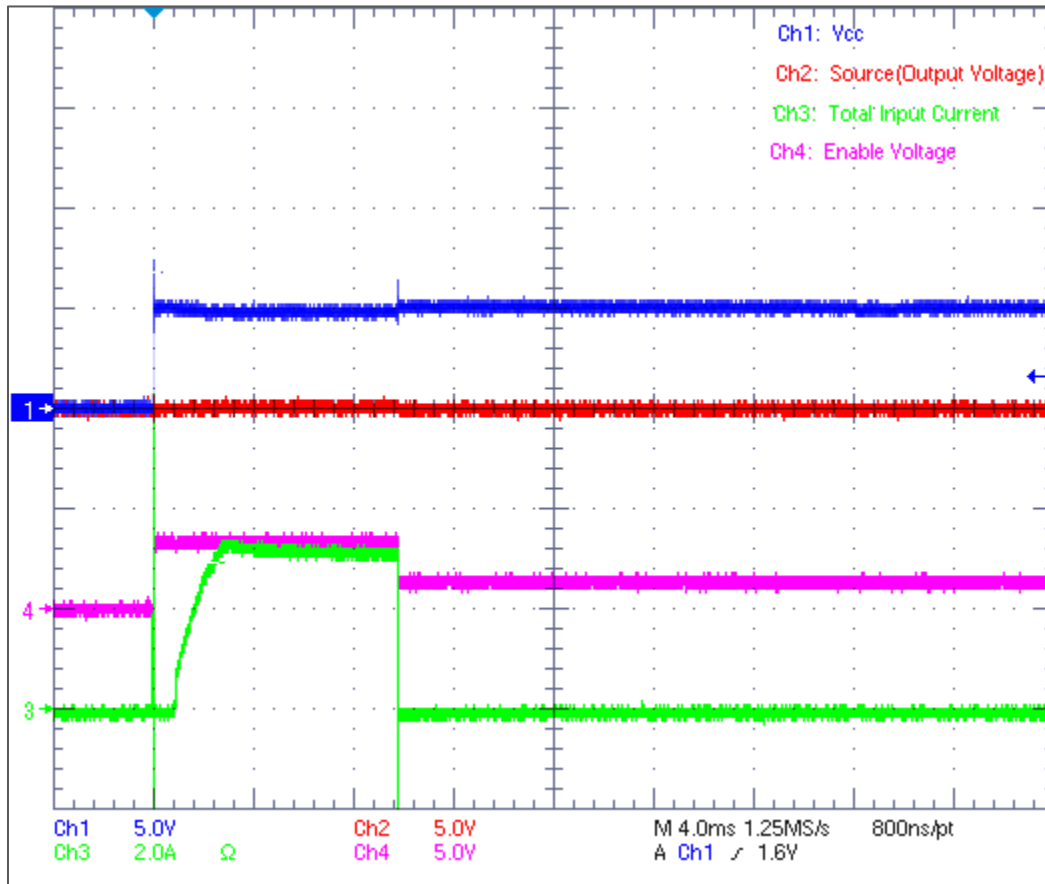

Figure 14: This shows a standard hot plug test. The input cable is manually plugged into the board and the output voltage rises slowly to minimize inrush current.

**NIS545x Hot Plug Power On into a Short Circuit**

Use jumpers J1 (545x), J2 (10 Ω) and J6 and connect a 5.0 ohm load. Short circuit the output using jumper J32 and manually take the 5 V power cable and plug it into the demo board. The eFuse briefly turns on and conducts at the short circuit current limit level. After some time the eFuse reaches the thermal shutdown level and latches off.



**Figure 15: This shows a hot plug test into a short circuit. The input cable is manually plugged into the board. The eFuse limits the current, enters thermal shutdown, and latches off.**







## Стандарт Электрон Связь

Мы молодая и активно развивающаяся компания в области поставок электронных компонентов. Мы поставляем электронные компоненты отечественного и импортного производства напрямую от производителей и с крупнейших складов мира.

Благодаря сотрудничеству с мировыми поставщиками мы осуществляем комплексные и плановые поставки широчайшего спектра электронных компонентов.

Собственная эффективная логистика и склад в обеспечивает надежную поставку продукции в точно указанные сроки по всей России.

Мы осуществляем техническую поддержку нашим клиентам и предпродажную проверку качества продукции. На все поставляемые продукты мы предоставляем гарантию .

Осуществляем поставки продукции под контролем ВП МО РФ на предприятия военно-промышленного комплекса России , а также работаем в рамках 275 ФЗ с открытием отдельных счетов в уполномоченном банке. Система менеджмента качества компании соответствует требованиям ГОСТ ISO 9001.

Минимальные сроки поставки, гибкие цены, неограниченный ассортимент и индивидуальный подход к клиентам являются основой для выстраивания долгосрочного и эффективного сотрудничества с предприятиями радиоэлектронной промышленности, предприятиями ВПК и научно-исследовательскими институтами России.

С нами вы становитесь еще успешнее!

### Наши контакты:

**Телефон:** +7 812 627 14 35

**Электронная почта:** [sales@st-electron.ru](mailto:sales@st-electron.ru)

**Адрес:** 198099, Санкт-Петербург,  
Промышленная ул, дом № 19, литера Н,  
помещение 100-Н Офис 331