

Infineon[®] Power LED Driver

TLD5045EJ

700mA High Integration - DC/DC Step-Down Converter

Datasheet

Rev. 1.0, 2011-05-27

Automotive Power

Table of Contents

	Table of Contents	2
1	Overview	3
2	Block Diagram	4
3	Pin Configuration	5
3.1	Pin Assignment	5
3.2	Pin Definitions and Functions	5
4	General Product Characteristics	7
4.1	Absolute Maximum Ratings	7
4.2	Functional Range	8
4.3	Thermal Resistance	8
5	Electrical Characteristics	9
5.1	General Parameters	9
5.2	Power Supply Monitoring	10
6	Enable, Dimming Function and Thermal Protection	11
6.1	Description	11
6.2	Electrical Characteristics Enable, Bias, Dimming Function and Thermal Protection	12
6.2.1	PWM Dimming with μC connected to TLD5045 PWMI pin	13
6.2.2	Internal PWM dimming Function	14
6.3	Overtemperature Protection of the Device	15
7	Open Load Diagnosis	16
7.1	Description	16
7.2	Electrical Characteristics: Open Load Diagnosis	16
7.3	Open Load Diagnosis in different Application Conditions	17
7.3.1	Light module application without μC	17
7.4	Application with μC connected to TLD5045 IC	18
8	Application Information	19
8.1	Output Peak Current Adjustment via R_{SET}	19
8.2	Switching Frequency Determination	20
8.3	TLD5045 in different LED Applications	22
8.3.1	TLD5045 in a Body Control Module (BCM) with μC Interface	22
8.3.2	Decentralized Light Module Application - DLM (Input configuration 1)	23
8.3.3	Decentralized Light Module Application - DLM (Input configuration 2)	24
8.3.4	Decentralized Light Module Application - DLM (Input configuration 3)	25
9	Package Outlines	26
10	Revision History	27



1 Overview

- Constant Current Generation
- Wide Input Voltage Range from 5V to 40V
- Peak Current Regulation
- Very low current consumption (<2uA) in Sleep Mode
- Integrated power transistor with low saturation voltage
- Integrated fast freewheeling diode
- Integrated load current sense resistor
- Integrated status pull down transistor
- Overtemperature Protection
- Switching frequency (typ. 200kHz) adjustable via external RC network
- External PWM Dimming Input
- Integrated PWM Dimming Engine
- Analog Dimming (output current adjustable via external low power resistor and possibility to connect PTC resistor for LED protection during overtemperature conditions)
- Stable switching frequency due to fix OFF-time concept with V_{REC} (supply voltage) feedforward
- Under- and Overvoltage shutdown with hysteresis
- Small thermally enhanced exposed heatslug SMD package
- Automotive AEC Qualified
- Green Product (RoHS) Compliant

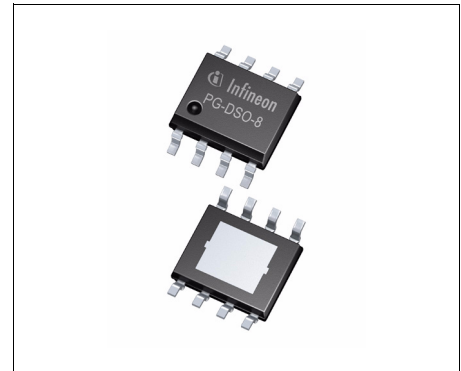

PG-DSO-8 EP

Description

The TLD5045 is a highly integrated smart LED buck controller with built in protection functions. The main function of this device is to drive single or multiple series connected LEDs efficiently from a voltage source higher than the LED forward voltage by regulating a constant LED current. The constant current regulation is especially beneficial for LED color accuracy and long LED lifetime. The built in freewheeling diode and switching transistor with current sense requires less external components and saves system costs. High flexibility is achieved by placing low power resistors to adjust output currents up to 700mA and the regulator switching frequency (typ. 200kHz). An integrated PWM dimming engine provides a LED dimming function by placing a simple RC network to GND. This feature is dedicated for decentralized light modules without micro controller involvement. In addition to that an integrated status pull down transistor can be used to simulate a minimum current flow for decentralized modules to avoid a wrong open load detection by a highside switch located in the body control module (BCM).

Applications

- Automotive LED driven Exterior Lighting: Brake, Tail, CHMSL, Daytime Running Light, Position Light
- Automotive LED driven Interior Lighting: Reading Light, Dome Light, Display Backlighting

Type	Package	Marking
TLD5045EJ	PG-DSO-8 EP	TLD5045

2 Block Diagram

The TLD5045 regulates the LED current by monitoring the load current (Peak Current Measurement) through the internal switch cycle by cycle. When the current through the switch reaches the threshold I_{peak} the switch is shut-OFF and it is kept OFF for a time equal to t_{OFF} . Both I_{peak} and t_{OFF} can be fixed through few external components. The peak current I_{peak} is fixed by a resistor connected to the SET pin while the t_{OFF} is fixed by RC network. As t_{OFF} is fixed and the duty cycle depends on V_{REC} , the frequency depends on V_{REC} as well. Refer to [Chapter 8.2](#) for the evaluation of the switching frequency.

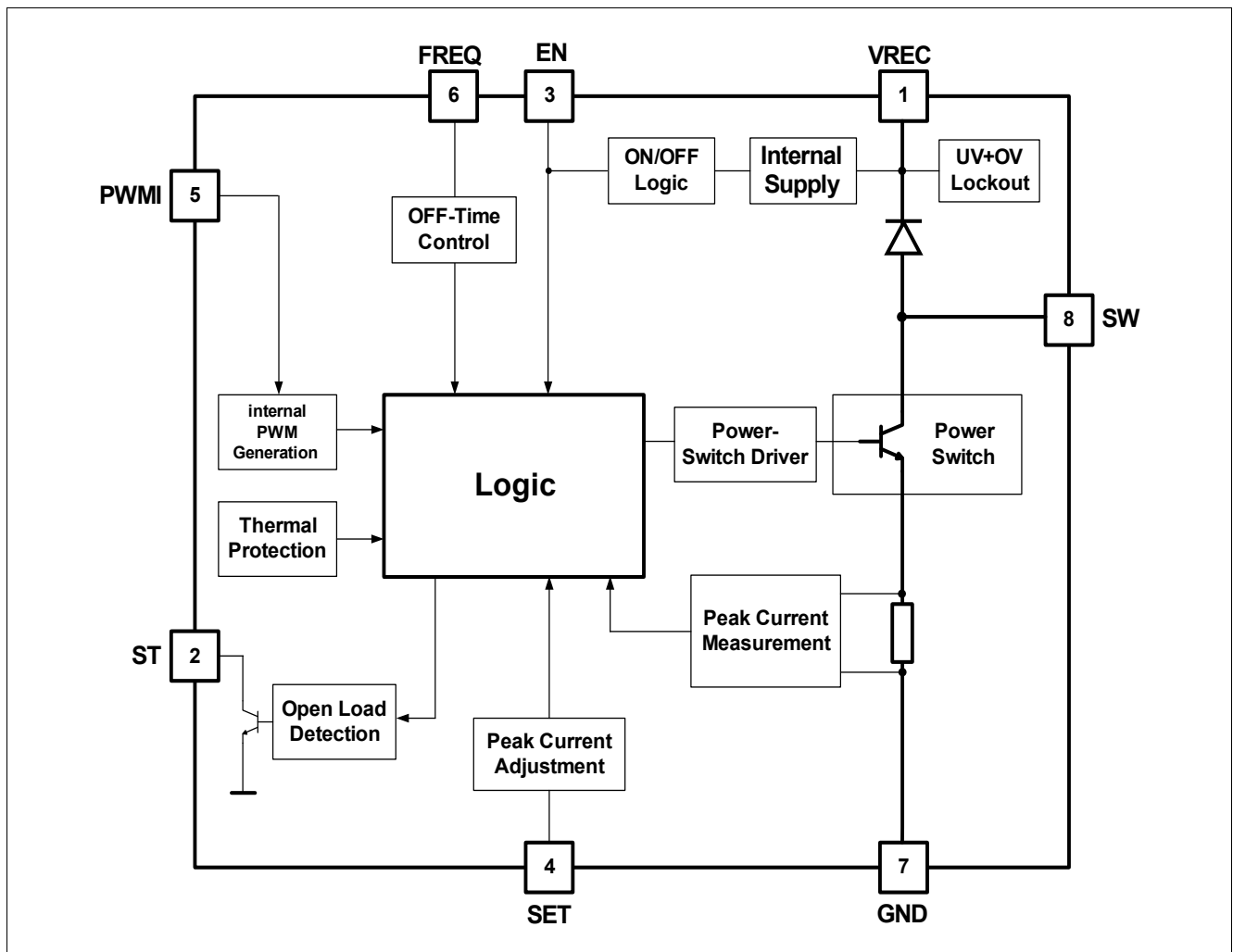

Figure 1 Block Diagram TLD5045

3 Pin Configuration

3.1 Pin Assignment

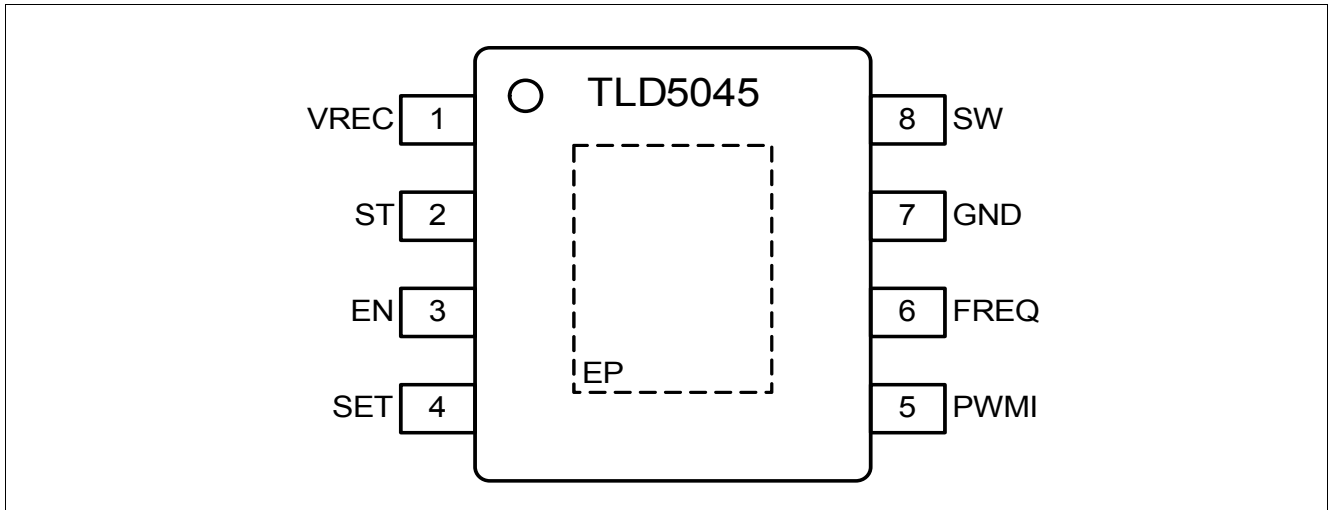

Figure 2 Pin Configuration TLD5045

3.2 Pin Definitions and Functions

Pin	Symbol	Function
1	VREC	Voltage Recirculation Output and Internal Supply Input; This pin is the supply pin of the IC (see block diagram). Furthermore the cathode of the integrated fast freewheeling diode is connected to this pin as well.
2	ST	Status Output; Open collector diagnostic output to indicate an open load failure. Refer to Chapter 7 for more details.
3	EN	Enable; Apply logic HIGH signal to enable the device
4	SET	SET Input; Connect a low power resistor to adjust the output current.
5	PWMI	PWM Input; PWM signal for dimming LEDs. Connect external R and C combination to achieve an auto PWM-dimming function with defined frequency and duty cycle. 1) internal PWM dimming function (external RC connected to GND) 2) external PWM dimming function (μ C is controlling this pin) Refer to Chapter 6 for more details.
6	FREQ	FREQuency Select Input; Connect external Resistor and Capacitor to GND to set the OFF-time of the switching frequency.
7	GND	Ground; Connect to system ground.

Pin Configuration

Pin	Symbol	Function
8	SW	Integrated Power-Switch Output; Collector of the integrated NPN-power transistor.
EP		Exposed Pad; Connect to external heatspreading copper area with electrically GND (e.g. inner GND layer of the PCB via thermal vias)

4 General Product Characteristics

4.1 Absolute Maximum Ratings

Absolute Maximum Ratings¹⁾

$T_j = -40\text{ °C}$ to $+150\text{ °C}$; all voltages with respect to ground (unless otherwise specified)

Pos.	Parameter	Symbol	Limit Values		Unit	Conditions
			Min.	Max.		
Voltages						
4.1.1	VREC (Pin 1) Recirculation and Supply Input	V_{REC}	-0.3	45	V	–
4.1.2	ST (Pin 2) Diagnostic Status Output Voltage	V_{ST}	-0.3	45	V	–
4.1.3	ST (Pin 2) Diagnostic Status Current	I_{ST}	–	150	mA	–
4.1.4	EN (Pin 3) Enable Input Voltage	V_{EN}	-0.3	45	V	–
4.1.5	SET (Pin 4) Peak Current Adjust Input Voltage	V_{SET}	-0.3	6	V	–
4.1.6	PWMI (Pin 5) PWM Input Voltage	V_{PWMI}	-0.3	6	V	–
4.1.7	FREQ (Pin 6) OFF-time Adjustment Input	V_{FREQ}	-0.3	6	V	–
4.1.8	SW (Pin 8) Switch Output	V_{SW}	-0.3	45	V	–
Temperatures						
4.1.9	Junction Temperature	T_j	-40	150	°C	–
4.1.10	Storage Temperature	T_{stg}	-55	150	°C	–
ESD Susceptibility						
4.1.11	ESD Resistivity all Pins to GND	$V_{ESD,HBM}$	-2	2	kV	HBM ²⁾

1) Not subject to production test, specified by design.

2) ESD susceptibility HBM according to EIA/JESD 22-A 114B

Note: Stresses above the ones listed here may cause permanent damage to the device. Exposure to absolute maximum rating conditions for extended periods may affect device reliability.

Note: Integrated protection functions are designed to prevent IC destruction under fault conditions described in the data sheet. Fault conditions are considered as "outside" normal operating range. Protection functions are not designed for continuous repetitive operation.

4.2 Functional Range

Pos.	Parameter	Symbol	Limit Values		Unit	Conditions
			Min.	Max.		
4.2.1	Extended Supply Voltage	V_{REC}	5	40 ¹⁾		parameter deviations possible
4.2.1	Nominal Supply Voltage Range	V_{REC}	8	36	V	–
4.2.2	Output current range	I_{OUT}	100	700	mA	–
4.2.3	Switching Frequency	f_{SW}	50	300 ¹⁾	kHz	$T_j = 25^\circ\text{C}$ to 150°C
4.2.4	Junction Temperature	T_j	-40	150	$^\circ\text{C}$	–

1) Not subject to production test, specified by design.

Note: Within the functional range the IC operates as described in the circuit description. The electrical characteristics are specified within the conditions given in the related electrical characteristics table.

4.3 Thermal Resistance

Note: This thermal data was generated in accordance with JEDEC JESD51 standards. For more information, go to www.jedec.org.

Pos.	Parameter	Symbol	Limit Values			Unit	Conditions
			Min.	Typ.	Max.		
4.3.1	Junction to Case	$R_{thJ-case}$	–	10	–	K/W	1) 2)
4.3.2	Junction to Ambient (2s2p)	R_{thJA}	–	40	–	K/W	1) 3)

1) Not subject to production test, specified by design.

2) Specified $R_{thJ-case}$ value is simulated at natural convection on a cold plate setup (all pins and the exposed Pad are fixed to ambient temperature). $T_a=25^\circ\text{C}$, Power Switch and freewheeling diode are dissipating 1W.

3) Specified R_{thJA} value is according to Jedec JESD51-2,-7 at natural convection on FR4 2s2p board; The Product (Chip+Package) was simulated on a 76.2 x 114.3 x 1.5 mm board with 2 inner copper layers (2 x 70 μm Cu, 2 x 35 μm Cu). According to JESD51-5 a thermal via array under the exposed pad contacted the first inner copper layer. $T_a=25^\circ\text{C}$, Power Switch and freewheeling diode are dissipating 1W.

5 Electrical Characteristics

5.1 General Parameters

Electrical Characteristics: Buck Regulator

$V_{REC} = 8\text{ V to }36\text{ V}$, $T_j = -40\text{ °C to }+150\text{ °C}$, all voltages with respect to ground (unless otherwise specified)

Pos.	Parameter	Symbol	Limit Values			Unit	Conditions
			Min.	Typ.	Max.		
5.1.1	Voltage Drop over Power Transistor	$V_{Drop,100}$	–	0.8	–	V	$I_{peak}=100\text{mA}$
5.1.2	Voltage Drop over Power Transistor	$V_{Drop,700}$	–	1.4	–	V	$I_{peak}=700\text{mA}$
5.1.3	Freewheeling diode forward voltage	$V_{fw,100}$	–	0.8	–	V	$I_{peak}=100\text{mA}$
5.1.4	Freewheeling diode forward voltage	$V_{fw,700}$	–	1.4	–	V	$I_{peak}=700\text{mA}$
5.1.5	Peak over current limit	I_{peak_lim}	–	1.4	–	A	–
5.1.6	Peak current accuracy	I_{peak_acc}	450	500	550	mA	$V_{REC} = 12\text{V}$ $V_{EN} = 5\text{V}$ $V_{LED} = 7.2\text{V}$ $R_{SET} = 14\text{k}\Omega$ $L_{SW} = 220\mu\text{H}$ $f_{SW} = 200\text{kHz}$
5.1.7	Input under voltage shutdown threshold	$V_{REC,UVOFF}$	–	–	5	V	$V_{EN} = 5\text{V}$ V_{REC} decreasing; see Figure 3
5.1.8	Input voltage startup threshold	$V_{REC,UVON}$	–	–	6	V	$V_{EN} = 5\text{V}$ V_{REC} increasing; see Figure 3
5.1.9	Input over voltage shutdown threshold	$V_{REC,OVOFF}$	40.5	–	–	V	$V_{EN} = 5\text{V}$ V_{REC} increasing; see Figure 3
5.1.10	Input over voltage startup threshold	$V_{REC,OV}$	40	–	–	V	$V_{EN} = 5\text{V}$ V_{REC} decreasing; see Figure 3
5.1.11	Switch ON delay	t_{dON}	–	400	600	ns	¹⁾ –
5.1.12	Switch OFF delay	t_{dOFF}	–	500	850	ns	¹⁾ –
5.1.13	Reference Voltage at SET pin	V_{SET}	1.16	1.225	1.29	V	–
5.1.14	Pull up current for FREQ pin	I_{FREQ}	5	–	–	mA	$V_{FREQ}=0\text{V}$
5.1.15	Oscillator switch off threshold	$V_{FREQ,HIGH}$	–	3.2	–	V	–
5.1.16	Oscillator switch on threshold	$V_{FREQ,LOW}$	–	1.2	–	V	–

1) The minimum switching ON time t_{ON} must be greater than $t_{dON} + t_{dOFF}$

5.2 Power Supply Monitoring

Over- and Undervoltage shutdown

If the supply voltage V_{REC} drops below the Input under voltage threshold voltage $V_{REC,UVoff}$, the power stage is switched OFF and the device is in normal consumption mode ($I_{q,ON}$).

If V_{REC} rises again and reaches the Input under voltage startup threshold $V_{REC,UVon}$ the power stage is restarted and the device is back to normal operation mode.

Same behavior applies to overvoltage.

The internal status transistor is switching off during an overvoltage or undervoltage event on V_{REC} .

A detailed description of the under- and overvoltage behavior is displayed in **Figure 3** below.

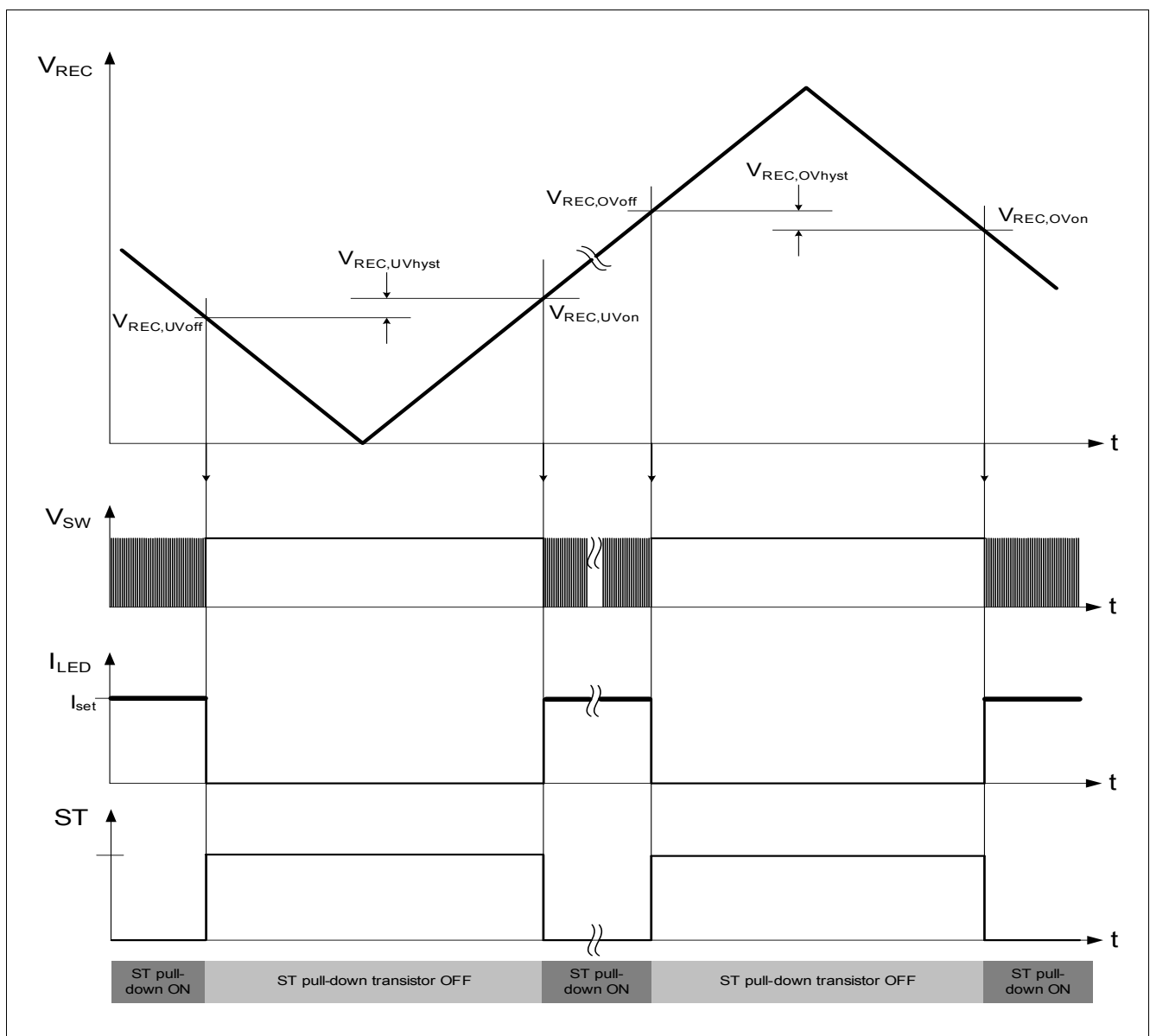

Figure 3 Over- and Undervoltage Protection

6 Enable, Dimming Function and Thermal Protection

6.1 Description

Enable function:

A logic high signal on the EN pin turns the device on. A logic low signal on enable pin EN brings the device in sleep mode. The current consumption is typ. 0.1µA in this case. The EN pin has an internal pull down resistor which ensures that the IC is in sleep mode and the power stage is switched off in case the pin EN is externally not connected.

Dimming function:

The PWMI pin combines two functions:

- 1) PWM dimming via a µC (3.3V and 5V µC)
- 2) Integrated PWM dimming engine for standalone solutions in decentralized light module (frequency and duty cycle adjustable via external R,C network)

A detailed description of the PWMI pin is displayed in [Figure 4](#) below.

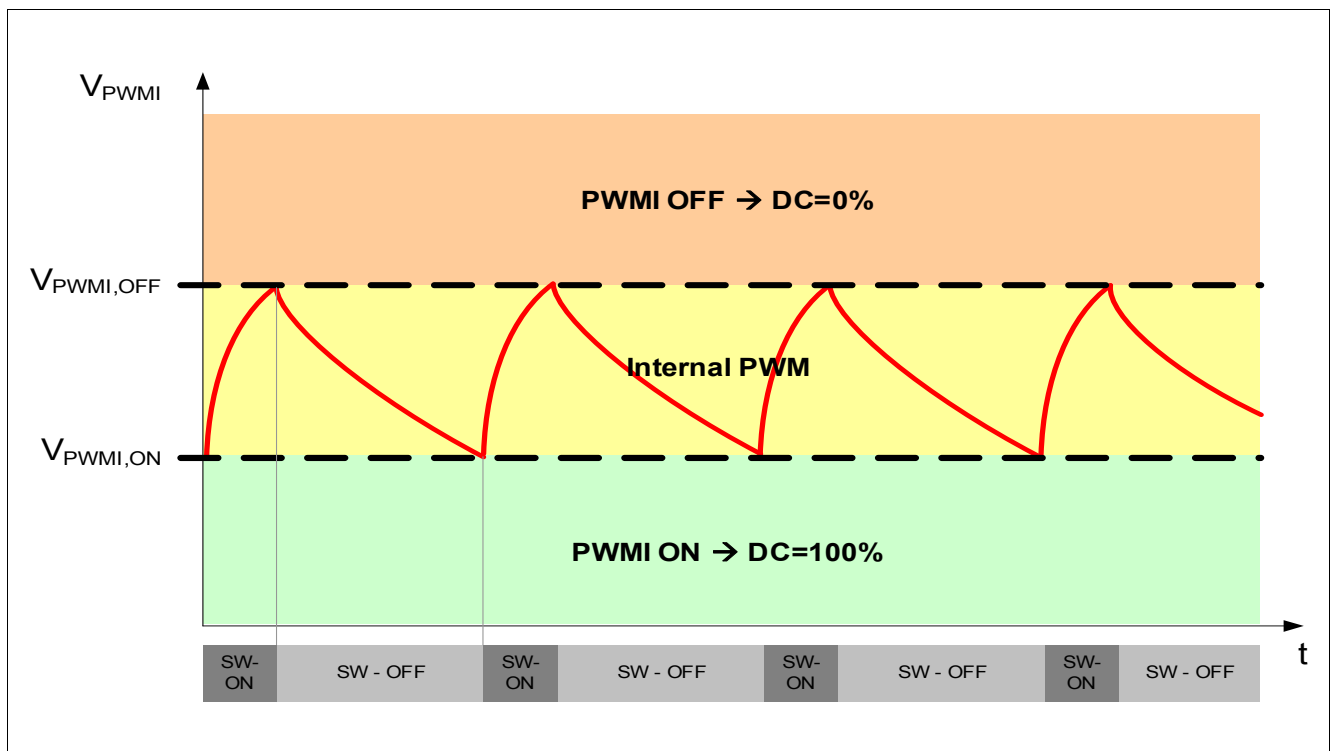

Figure 4 PWMI Pin description

6.2 Electrical Characteristics Enable, Bias, Dimming Function and Thermal Protection

Electrical Characteristics: Enable, Bias, Dimming Function and Thermal Protection

$V_{REC} = 8\text{ V to }36\text{ V}$, $T_j = -40\text{ °C to }+150\text{ °C}$, all voltages with respect to ground (unless otherwise specified)

Pos.	Parameter	Symbol	Limit Values			Unit	Conditions
			Min.	Typ.	Max.		
6.2.1	Current Consumption, sleep mode	$I_{q,OFF}$	–	0.1	2	μA	$V_{EN} = 0\text{V}$; $V_{REC} = 16\text{V}$
6.2.2	Current Consumption, active mode (Open Load)	$I_{q,ON}$	–	–	5	mA	$V_{EN} = 5.0\text{V}$; $I_{peak} = 0\text{mA}$ (open load); $V_{REC} = 16\text{V}$
6.2.3	Current Consumption, active mode	$I_{q,ON}$	–	–	10	mA	$V_{EN} = 5.0\text{V}$; $I_{peak} = 700\text{mA}$ $V_{REC} = 16\text{V}$
6.2.4	EN Turn On Threshold	$V_{EN,ON}$	2.8	–	–	V	–
6.2.5	EN Turn Off Threshold	$V_{EN,OFF}$	–	–	0.8	V	–
6.2.6	EN high input current	$I_{EN,hi}$	–	100	–	μA	$V_{EN} = 5\text{V}$
6.2.7	EN low input current	$I_{EN,lo}$	0	–	20	μA	$V_{EN} = 0.5\text{V}$
6.2.8	PWMI Turn On Threshold	$V_{PWMI,ON}$	–	1	–	V	see Figure 4
6.2.9	PWMI Turn Off Threshold	$V_{PWMI,OFF}$	–	2	–	V	see Figure 4
6.2.10	PWMI source current	I_{PWMI}	–	250	–	μA	$R_{set} = 10\text{k}\Omega$ $V_{PWMI} = 0.5\text{V}$;
6.2.11	Over temperature shutdown	$T_{j,sd}$	150	175	–	$^{\circ}\text{C}$	1)
6.2.12	Over temperature shutdown hysteresis	T_{j,sd_hyst}	–	15	–	K	1)

1) Specified by design. Not subject to production test.

6.2.1 PWM Dimming with μC connected to TLD5045 PWMI pin

The PWMI pin can be used for PWM dimming. It is a commonly practiced dimming method to prevent color shift in LED light applications.

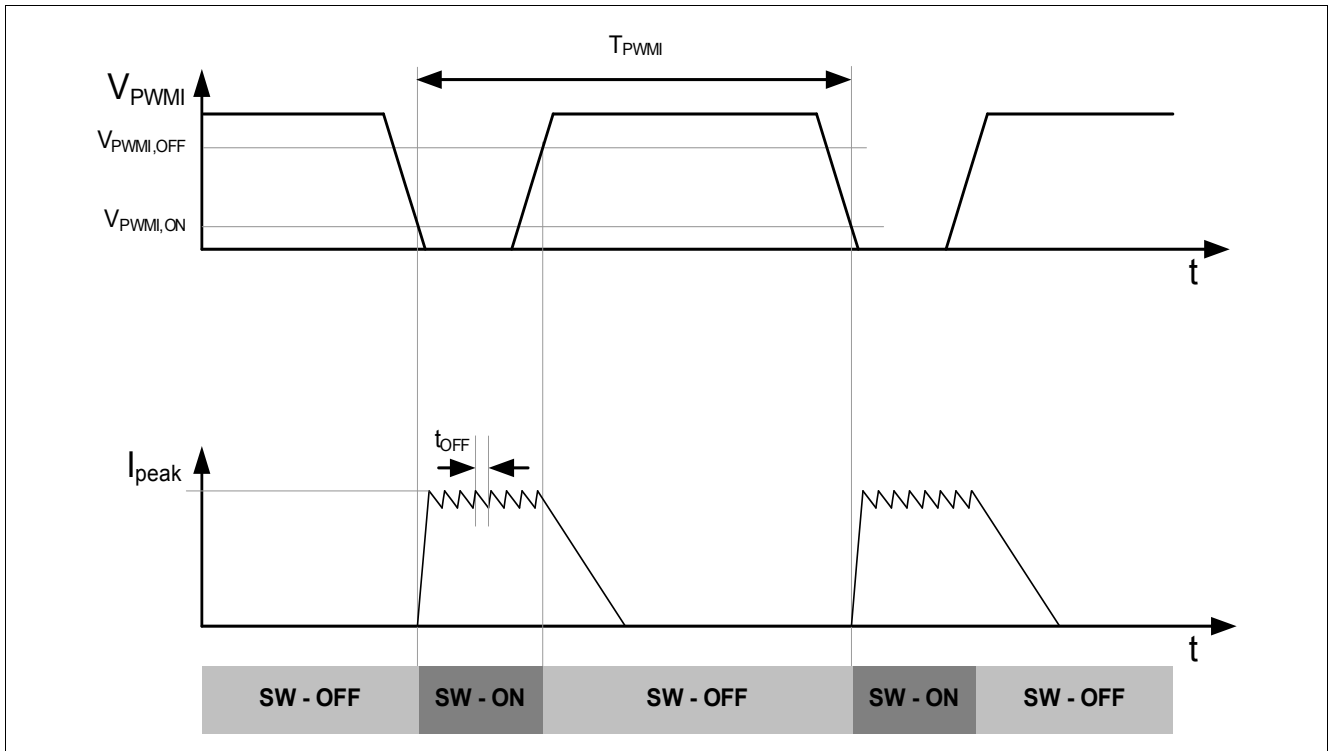

Figure 5 Timing Diagram for LED Dimming with μC

6.2.2 Internal PWM dimming Function

The TLD5045 has an integrated PWM dimming engine. Via an external R_{PWM} and C_{PWM} network it is possible to achieve a PWM LED current waveform. The duty cycle and dimming frequency is depending on the size of the external components (see formula in Figure 7). This feature is specially designed to achieve a stand alone PWM dimming function without the usage of micro controllers or external logic. This allows a flexible and cost effective usage of the device in a decentralized light module application (refer to application drawing Figure 15).

The advantage of a PWM dimming (to reduce the LED load current) is the change of light intensity only, at constant light color.

With an external RC network a PWM programming between 100Hz and 1200Hz and Duty Cycles between 4% and max. 20%. is possible. Figure 6 displays the external components corresponding to the desired PWM frequency and duty cycle.

The following setup applies for the table displayed in Figure 6: $V_{REC}=12V$, $V_{LED}=7.2V$, $L_{SW}=220\mu H$, $R_{SET}=14k\Omega$.

R_{PWM}	C_{PWM}	f_{PWM}	DC
216k Ω	64nF	100Hz	4%
216k Ω	32nF	200Hz	4%
216k Ω	21nF	300Hz	4%
216k Ω	16nF	400Hz	4%
87k Ω	150nF	100Hz	10%
87k Ω	75nF	200Hz	10%
87k Ω	50nF	300Hz	10%
87k Ω	37nF	400Hz	10%
44k Ω	265nF	100Hz	20%
44k Ω	132nF	200Hz	20%
44k Ω	88nF	300Hz	20%
44k Ω	66nF	400Hz	20%

Figure 6 R_{PWM} and C_{PWM} versus f_{PWM} and DC

6.3 Overtemperature Protection of the Device

A temperature sensor at the power stage causes the overheated device to switch OFF to prevent destruction. During over temperature condition the internal ST transistor is switched OFF. Due to the autorestart function of the device the status signal will toggle accordingly. The timing of this pattern is dependant on the thermal capability of the application and can be used to distinguish between open load error and overtemperature condition. More details on the overtemperature behavior is displayed in [Figure 7](#) below.

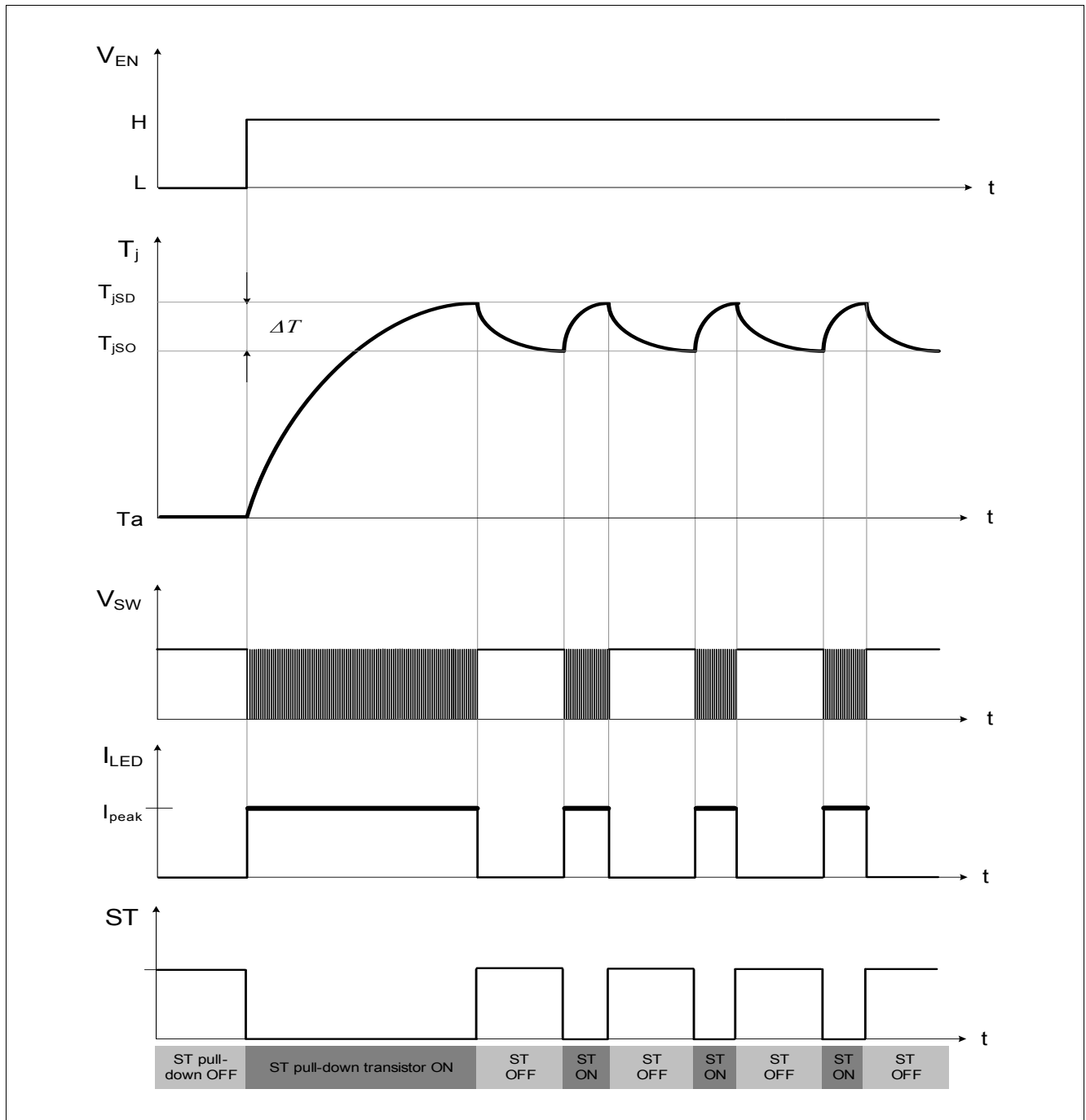

Figure 7 Overtemperature Behavior

7 Open Load Diagnosis

7.1 Description

The **TLD5045** has an integrated open load during ON diagnosis. During normal operation the ST pin (open collector output) is pulled to GND (internal transistor is ON). The open load detection is realized by monitoring the switching behavior at the SW pin. During an open load event the integrated power stage at the SW pin will be statically turned ON. If the output stage is turned ON for more than the open load diagnosis delay time (t_{OL}) an open load condition is detected. An open load event will switch OFF the internal transistor. If a μC is connected to the ST pin an external pull up resistor should be placed to achieve a logic HIGH level for the proper open load error signalling reporting. For a timing diagram on the functionality of the open load diagnosis please refer to figure [Figure 8](#) and [Figure 9](#).

7.2 Electrical Characteristics: Open Load Diagnosis

Electrical Characteristics: Open Load Diagnosis

$V_{REC} = 8\text{ V to }36\text{ V}$, $T_j = -40\text{ }^\circ\text{C to }+150\text{ }^\circ\text{C}$, all voltages with respect to ground (unless otherwise specified)

Pos.	Parameter	Symbol	Limit Values			Unit	Conditions
			Min.	Typ.	Max.		
7.2.1	Open Load diagnosis DelayTime	t_{OL}	20	–	–	μs	–
7.2.2	Voltage Drop over internal ST transistor	$V_{Drop,ST}$	–	0.3	–	V	$I_{ST}=150\text{mA}$

7.3 Open Load Diagnosis in different Application Conditions

7.3.1 Light module application without μC

Most of the time, the open load diagnosis of the whole light module is done via the current sense of the driver IC (e.g. PROFET) located in the light control module (or BCM module). See [Figure 15](#) for a simplified application schematic. The light module needs to sink a specified minimum current (e.g. 100mA) to indicate normal operation. To guarantee this minimum current also under light load conditions (e.g. high efficiency LED bin at high supply voltages = min. load current required) system designers often have to place resistors in parallel to the application circuit (see Resistors connected to supply lines in [Figure 15](#)). When using such resistors connected between V_S and GND, an open LED diagnosis is not possible anymore. To overcome this issue an internal transistor (open collector) is connected to the ST pin of the **TLD5045**. During normal operation the ST pin is LOW and a minimum module current can be guaranteed.

As soon as an open load occurs the internal ST transistor switches off. Due to this, the current on the V_{REC} pin decreases below the open load detection threshold of the driver IC located in the light control module.

Note: Open Load is only detected during the ON cycle of the switching transistor. During the OFF state the ST signal displays what was detected in the previous ON state.

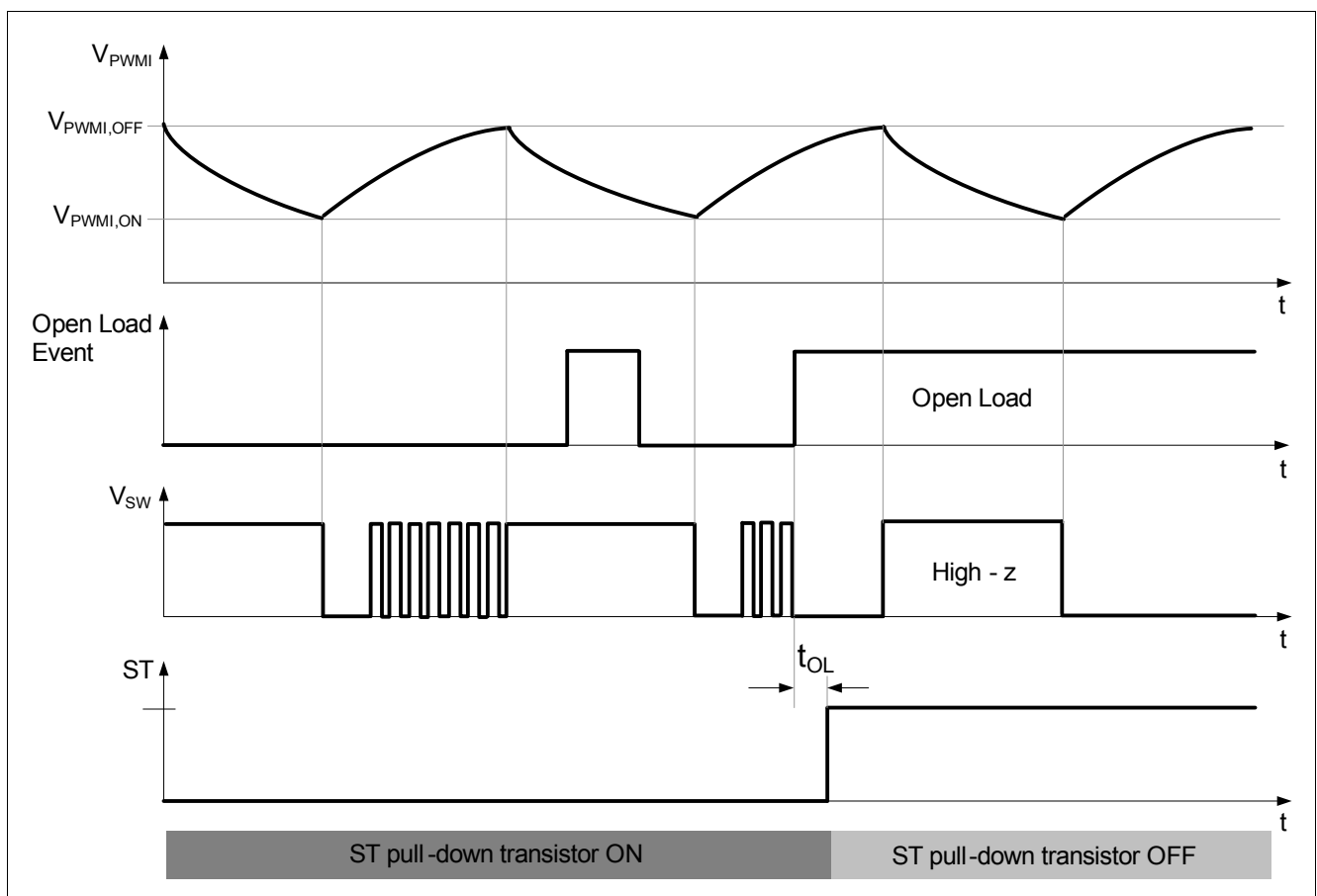

Figure 8 Open Load Diagnosis using Internal PWM Mode

7.4 Application with μC connected to TLD5045 IC

The ST pin can be connected directly to a μC input. During an open load condition the ST transistor is OFF. An external pull up resistor connected to V_{DD} is required to signal a logic high signal on the ST pin during an open load error. Please consider that this diagnosis functionality is only active if the device is in active mode (HIGH potential at the EN pin).

Refer to application drawing [Figure 14](#).

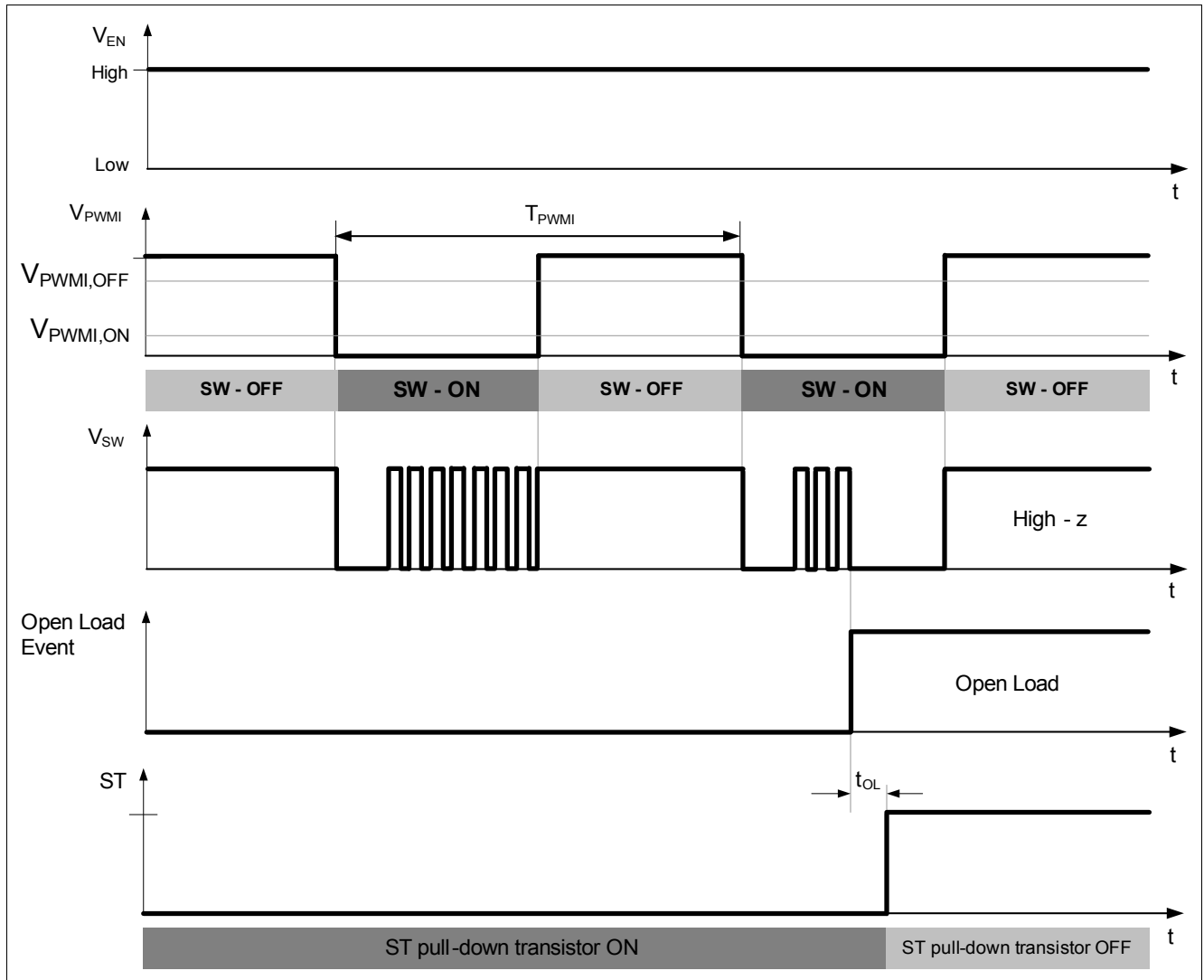

Figure 9 Open Load diagnosis via μC connected to ST pin

8 Application Information

Note: The following information is given as a hint for the implementation of the device only and shall not be regarded as a description or warranty of a certain functionality, condition or quality of the device.

8.1 Output Peak Current Adjustment via R_{SET}

The external resistor R_{SET} is used to adjust the peak current of the regulator. Maximum achievable peak current is 700mA and minimum achievable peak current is 100mA. The SET pin provides an internally fixed voltage level at typ.: 1.225V. Out of this considerations the equation is:

$$I_{\text{peak}} = (1.225V / R_{\text{SET}}) * 5710$$

The factor 5710 is derived from following considerations:

- I_{peak, max} = 700mA (R_{SET} = 10kΩ)
- I_{peak, min} = 100mA (R_{SET} = 70kΩ)

Internal comparator voltage at SET pin = 1.225V.

The circuitry behind the SET pin is adjusting higher peak currents with lower R_{SET} values.

The R_{SET} value should be in the range from 10kΩ to 70kΩ to achieve the requested peak current range.

The following setup applies for the table displayed in [Figure 10](#): V_{REC}=12V, V_{LED}=7.2V, L_{SW}=220μH.

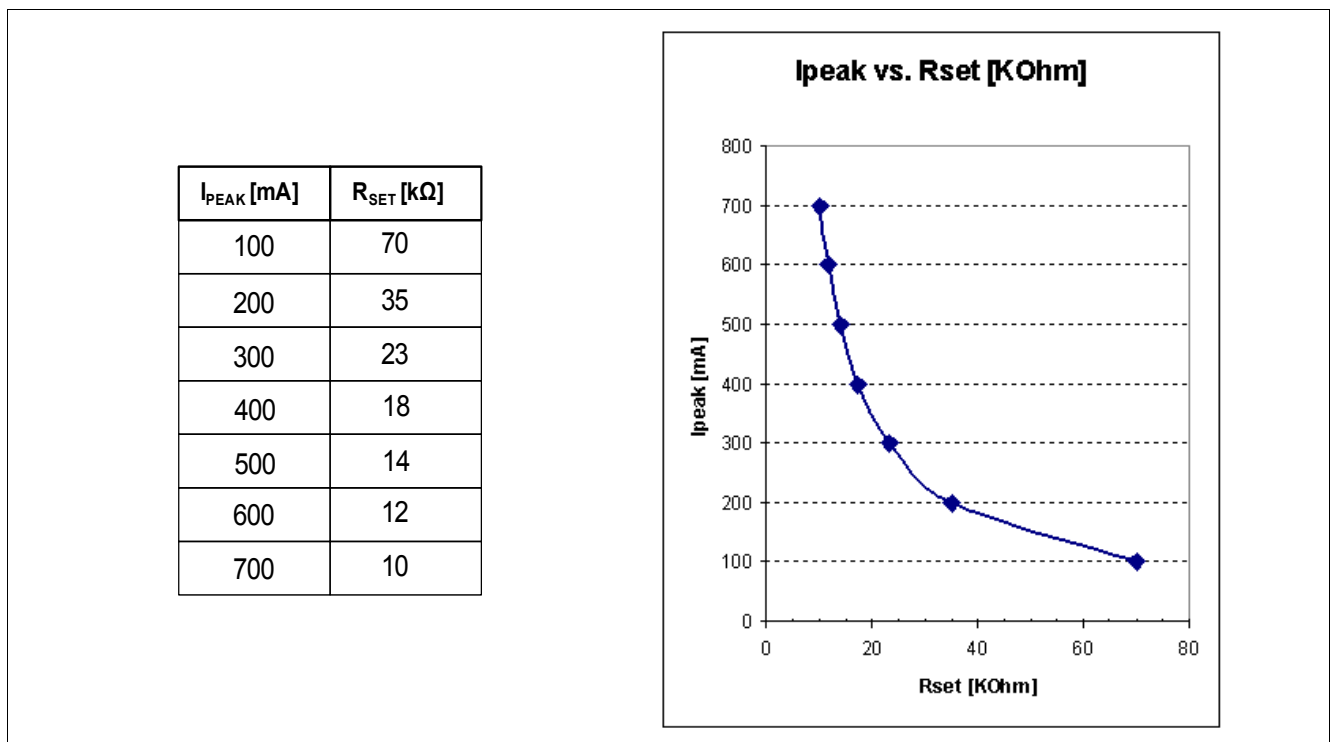

Figure 10 R_{SET} Resistor Selection

8.2 Switching Frequency Determination

With the external R_{FREQ} , C_{FREQ} and R_{COMP} network, it is possible to adjust the switching frequency of the regulator. To ensure a stable frequency over a broad range of input voltage V_{REC} an external resistor R_{COMP} can be used. The following setup applies for the table displayed in **Figure 12**: $V_{REC}=12V$, $V_{LED}=7.2V$, $L_{SW}=220\mu H$, $R_{SET}=14k\Omega$.

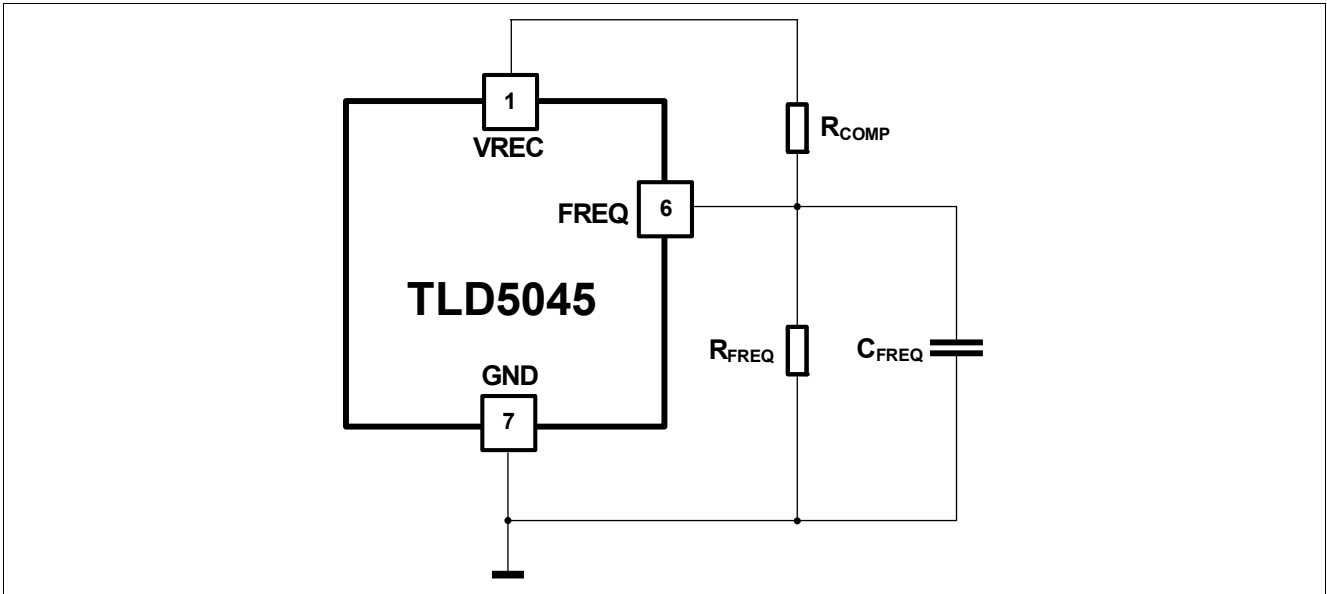

Figure 11 Setting t_{OFF} Time of Regulator with External R_{FREQ} , C_{FREQ} Network

R_{comp}	R_{freq}	C_{freq}	f_{sw}	t_{off}
255.8k Ω	17.1k Ω	220pF	50kHz	6.47 μ s
115.8k Ω	7.7k Ω	220pF	100kHz	3.19 μ s
69.7k Ω	4.6k Ω	220pF	150kHz	2.12 μ s
46.8k Ω	3.1k Ω	220pF	200kHz	1.59 μ s
72.8k Ω	4.9k Ω	100pF	250kHz	1.27 μ s
52.7k Ω	3.5k Ω	100pF	300kHz	1.06 μ s

Figure 12 R_{FREQ} , C_{FREQ} versus f_{SW} Table

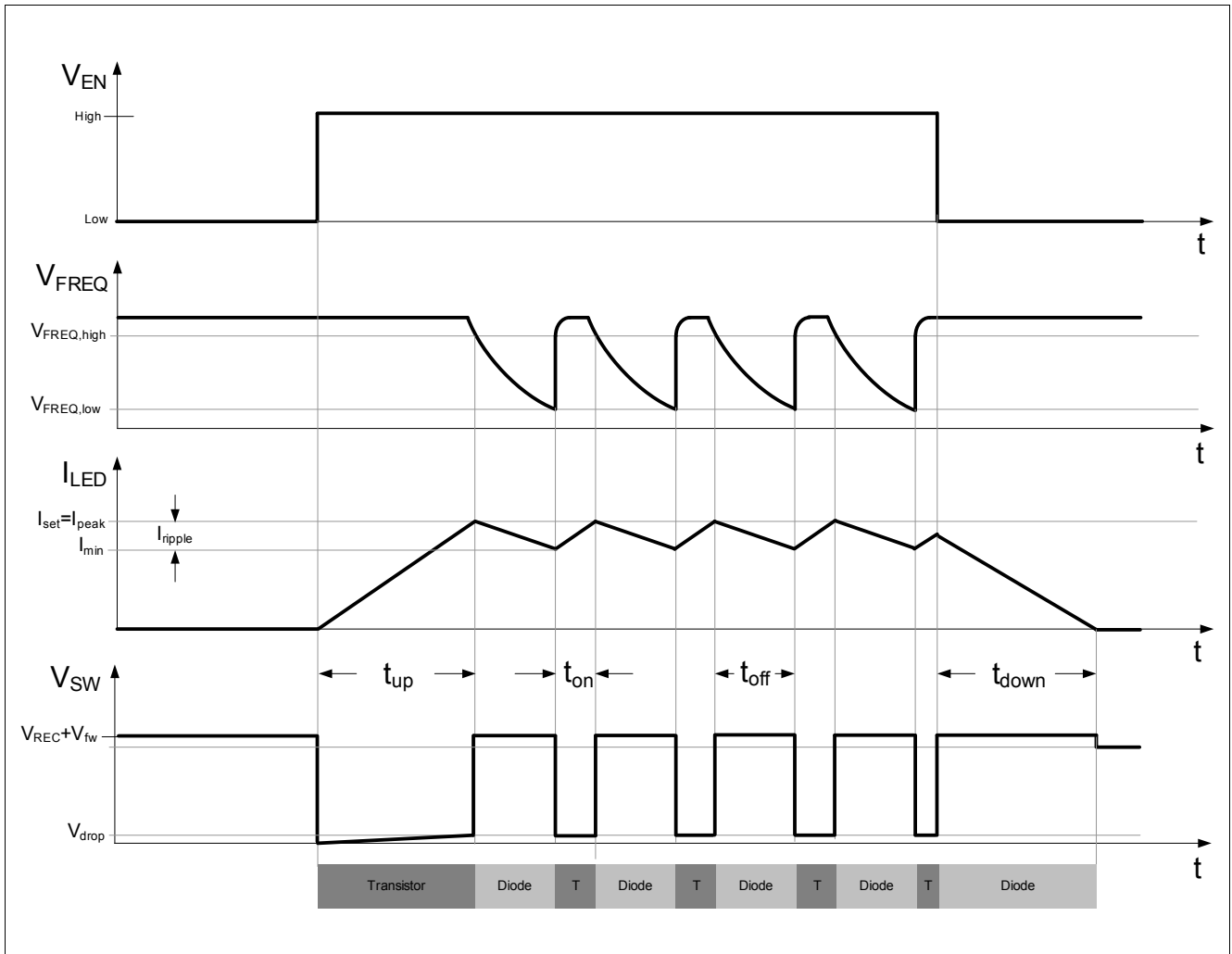

Figure 13 Theoretical Operating Waveforms

8.3 TLD5045 in different LED Applications

8.3.1 TLD5045 in a Body Control Module (BCM) with μC Interface

Figure 14 provides a simplified application with two high brightness LEDs in series. A μC is controlling the EN pin to put the device into sleep/active mode. Also the PWMI pin can be directly controlled via a μC port if PWM dimming of the LED current is required. The open load ST pin monitors the load condition of the application and gives feedback to the μC . An external pull up resistor is recommended to achieve a logic HIGH signal during an open load error (internal status transistor is switched OFF and the ST pin is high ohmic an external pull up resistor ensures a logic HIGH signal).

The external low power resistor R_{SET} is used to set the required peak current for the LED load (refer to **Figure 10** for more details).

To set the desired switching frequency of the buck regulator the external R_{FREQ} and C_{FREQ} network must be connected to GND (reference values are given in **Figure 12**).

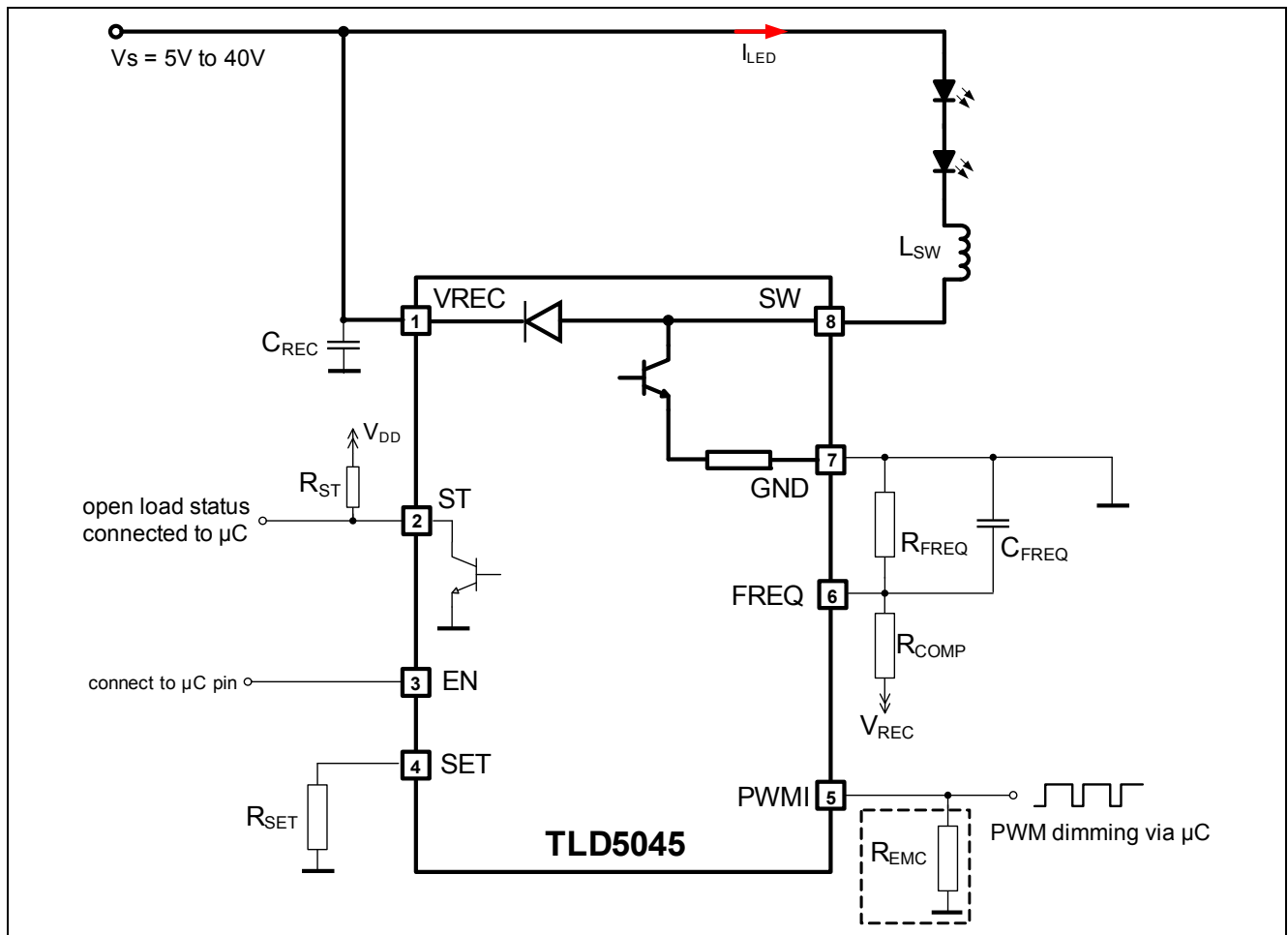

Figure 14 Simplified Application Diagram TLD5045

Note: This is a very simplified example of an application circuit. The function must be verified in the real application

8.3.2 Decentralized Light Module Application - DLM (Input configuration 1)

The connection between the Body Control Module (BCM) and the Decentralized Light Module is realized via one supply line and one GND connection.

The supply line could change between two different operation modes:

1) Light Function 1 - Daytime Running Light (DRL) mode: If the supply line is permanently ON, the DRL application which requires higher LED current (e.g. 400mA) is active. The proper R_{SET} resistor should be placed to achieve the desired load current (e.g. 18k Ω).

2) Light Function 2 - Position Light (PL) mode: During a PWM signal (e.g. 200Hz) on the supply line the mean LED current is reduced to a lower level (e.g. 50mA) and the application is entering into PL mode. The enable pin of the TLD5045 is a high voltage pin (max. 45V) and can be directly connected via a resistor R_{EN} before the reverse polarity protection diode of the module to achieve a fast capture of the PWM signal. The PWMI pin is connected to GND (inverse logic = ON).

To simulate a module current during light load conditions, the ST pin can be connected via a resistor to the supply voltage line. (refer to [Chapter 7](#) for a detailed description of the ST behavior)

For a decentralized solution without micro controller involvement the possibility to connect a PTC resistor at the SET pin is a cost effective solution to protect the LED load from thermal destruction.

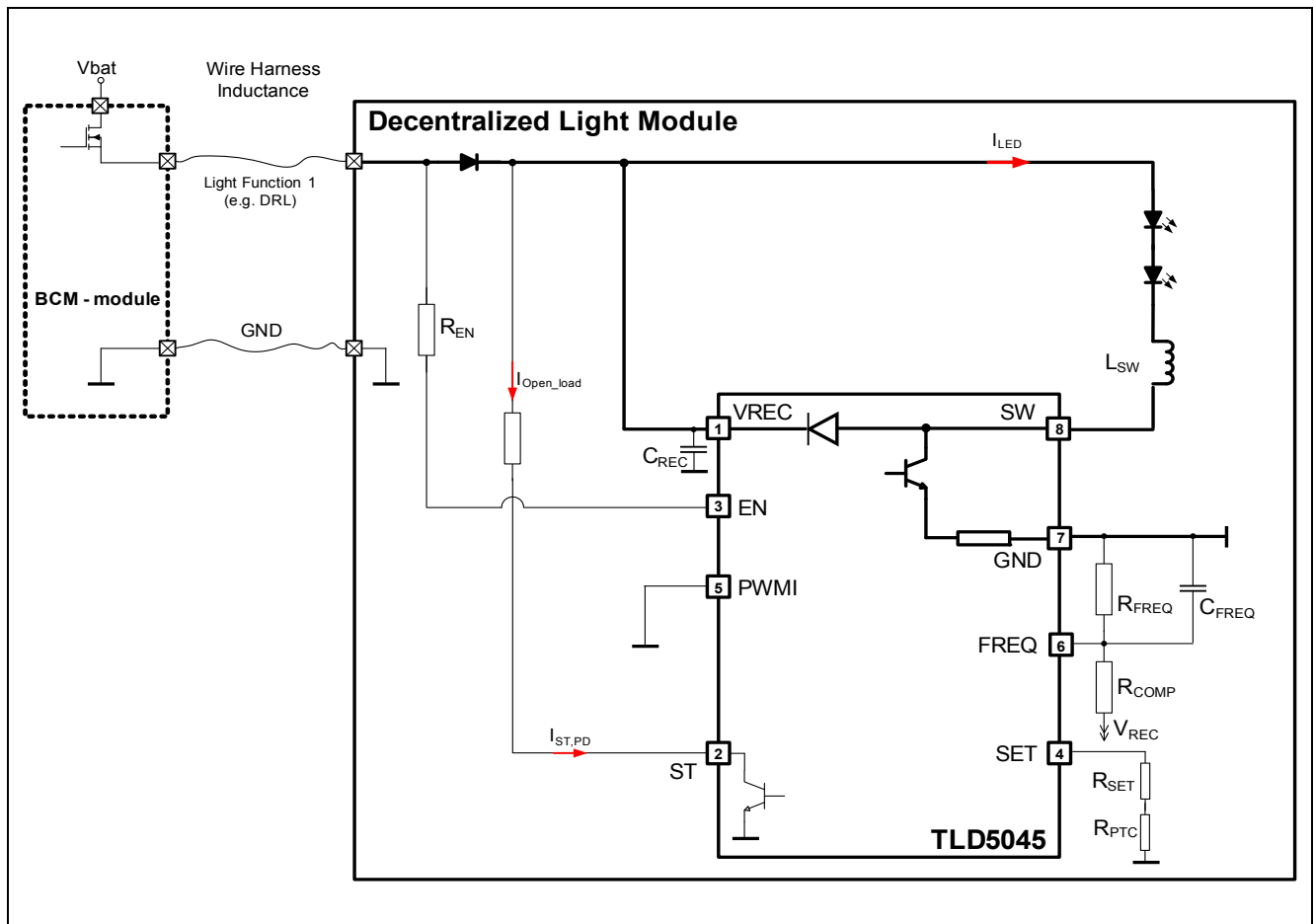

Figure 15 Application Diagram of Decentralized Light Module without μC (input config 1)

This is a very simplified example of an application circuit. The function must be verified in the real application

8.3.3 Decentralized Light Module Application - DLM (Input configuration 2)

In this particular input configuration two supply lines are tied together on the DLM. The following input states must be considered to distinguish between Light Function 1 (DRL mode) and Light Function 2 (PL mode).

- 1) Condition: DRL = ON, PL = OFF. Desired function: DRL mode (e.g. 400mA LED load current)
- 2) Condition: DRL = OFF, PL = ON. Desired function: PL mode (e.g. 50mA LED load current)
- 3) Condition: DRL = ON, PL =ON. Desired function: PL mode (e.g. 50mA LED load current)

To achieve a lower mean LED load current during the PL mode the integrated PWM engine is a useful feature. The external R_{PWM} and C_{PWM} circuit predefines a dedicated PWM frequency and duty cycle. (for details refer to [Figure 11](#))

To simulate a module current during light load conditions the ST pin can be connected via resistors to both supply voltage lines. (refer to [Chapter 7](#) for a detailed description of the ST behavior)

For a decentralized solution without micro controller involvement the possibility to connect a PTC resistor at the SET pin is a cost effective solution to protect the LED load from thermal destruction.

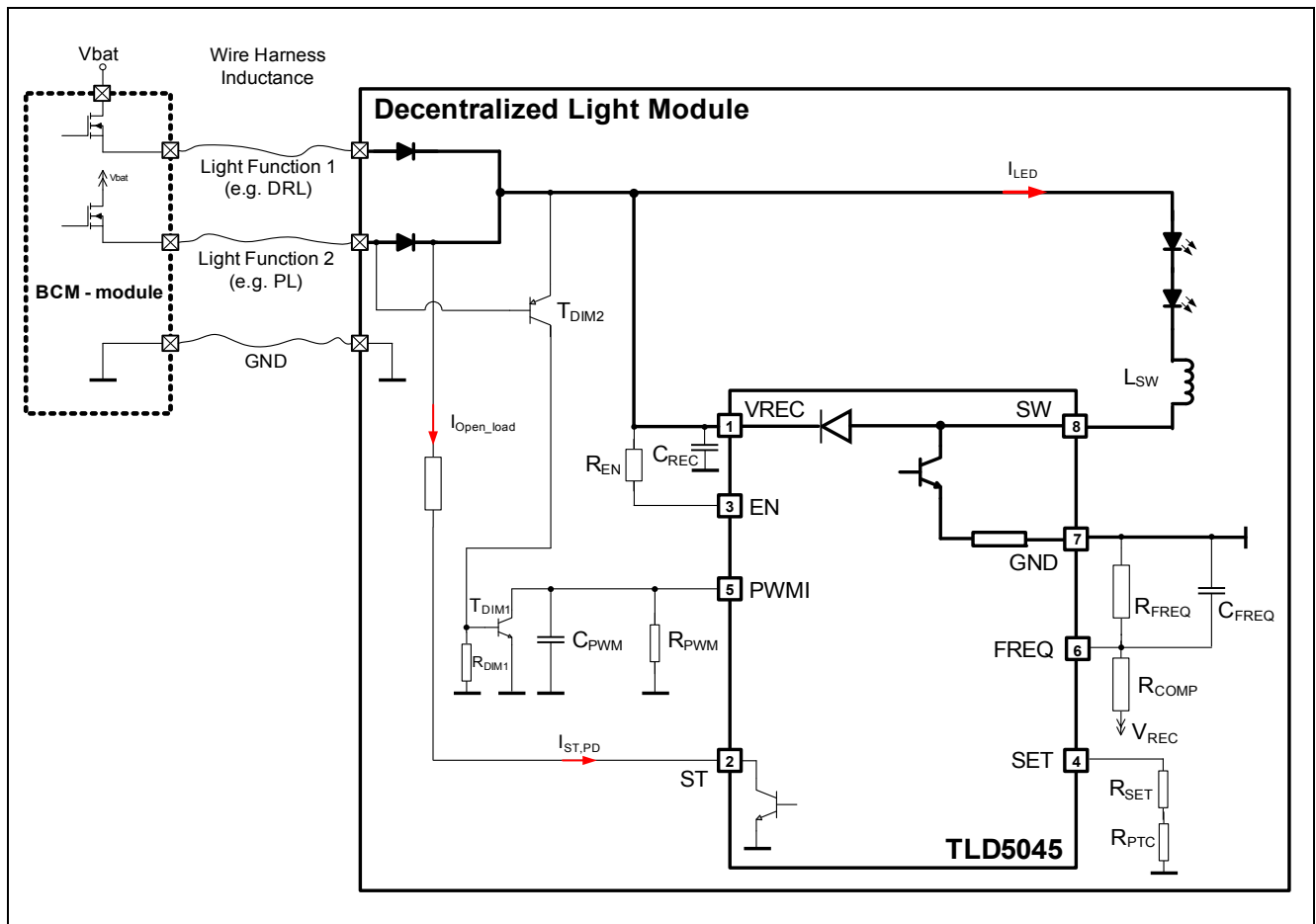

Figure 16 Application Diagram of Decentralized Light Module without μC (input config 2)

This is a very simplified example of an application circuit. The function must be verified in the real application

8.3.4 Decentralized Light Module Application - DLM (Input configuration 3)

A permanent supply chooses the Light Function 1 (DRL mode) and a second dedicated PWM supply between 100Hz and 200Hz switches to Light Function 2 (PL mode). For this input configuration it is possible to connect the PWM dimming output of the BCM directly to the PWMI input of the **TLD5045**. To simulate a module current during light load conditions the ST pin can be connected via a resistor to the permanent supply voltage line. (refer to [Chapter 7](#) for a detailed description of the ST behavior)

For a decentralized solution without micro controller involvement the possibility to connect a PTC resistor at the SET pin is a cost effective solution to protect the LED load from thermal destruction. (for details refer to [Figure 15](#))

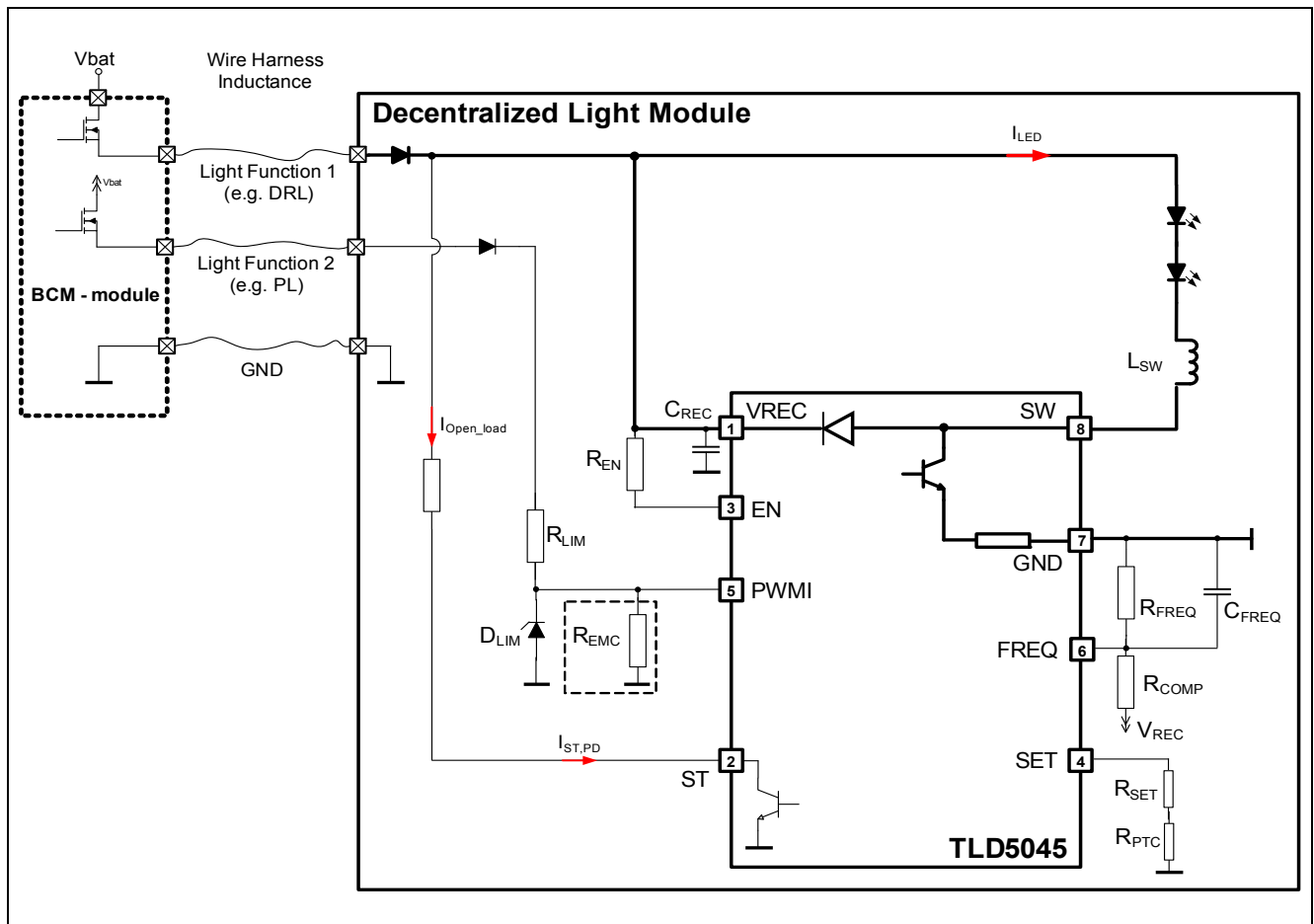

Figure 17 Application Diagram of Decentralized Light Module without μC (input config 3)

This is a very simplified example of an application circuit. The function must be verified in the real application

9 Package Outlines

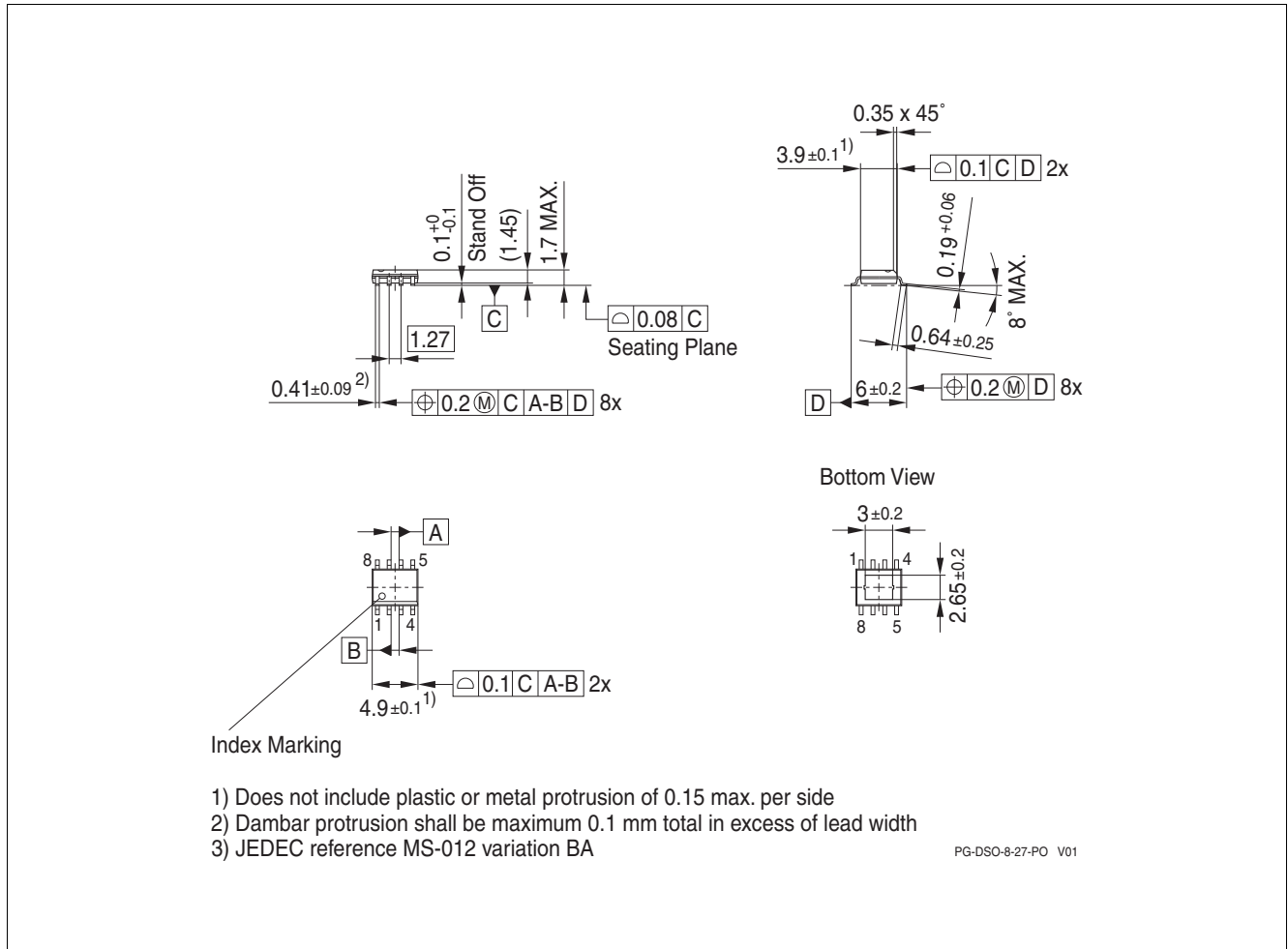

Figure 18 Outline PG-DSO-8 EP

Green Product (RoHS compliant)

To meet the world-wide customer requirements for environmentally friendly products and to be compliant with government regulations the device is available as a green product. Green products are RoHS-Compliant (i.e. Pb-free finish on leads and suitable for Pb-free soldering according to IPC/JEDEC J-STD-020).

For further package information, please visit our website:
<http://www.infineon.com/packages>.

Dimensions in mm

10 Revision History

Version	Date	Changes
Rev. 1.0	2011-05-27	Initial Data sheet for TLD5045

Edition 2011-05-27

**Published by
Infineon Technologies AG
81726 Munich, Germany**

**© 2011 Infineon Technologies AG
All Rights Reserved.**

Legal Disclaimer

The information given in this document shall in no event be regarded as a guarantee of conditions or characteristics. With respect to any examples or hints given herein, any typical values stated herein and/or any information regarding the application of the device, Infineon Technologies hereby disclaims any and all warranties and liabilities of any kind, including without limitation, warranties of non-infringement of intellectual property rights of any third party.

Information

For further information on technology, delivery terms and conditions and prices, please contact the nearest Infineon Technologies Office (www.infineon.com).

Warnings

Due to technical requirements, components may contain dangerous substances. For information on the types in question, please contact the nearest Infineon Technologies Office.

Infineon Technologies components may be used in life-support devices or systems only with the express written approval of Infineon Technologies, if a failure of such components can reasonably be expected to cause the failure of that life-support device or system or to affect the safety or effectiveness of that device or system. Life support devices or systems are intended to be implanted in the human body or to support and/or maintain and sustain and/or protect human life. If they fail, it is reasonable to assume that the health of the user or other persons may be endangered.



Стандарт Электрон Связь

Мы молодая и активно развивающаяся компания в области поставок электронных компонентов. Мы поставляем электронные компоненты отечественного и импортного производства напрямую от производителей и с крупнейших складов мира.

Благодаря сотрудничеству с мировыми поставщиками мы осуществляем комплексные и плановые поставки широчайшего спектра электронных компонентов.

Собственная эффективная логистика и склад в обеспечивает надежную поставку продукции в точно указанные сроки по всей России.

Мы осуществляем техническую поддержку нашим клиентам и предпродажную проверку качества продукции. На все поставляемые продукты мы предоставляем гарантию .

Осуществляем поставки продукции под контролем ВП МО РФ на предприятия военно-промышленного комплекса России , а также работаем в рамках 275 ФЗ с открытием отдельных счетов в уполномоченном банке. Система менеджмента качества компании соответствует требованиям ГОСТ ISO 9001.

Минимальные сроки поставки, гибкие цены, неограниченный ассортимент и индивидуальный подход к клиентам являются основой для выстраивания долгосрочного и эффективного сотрудничества с предприятиями радиоэлектронной промышленности, предприятиями ВПК и научно-исследовательскими институтами России.

С нами вы становитесь еще успешнее!

Наши контакты:

Телефон: +7 812 627 14 35

Электронная почта: sales@st-electron.ru

Адрес: 198099, Санкт-Петербург,
Промышленная ул, дом № 19, литера Н,
помещение 100-Н Офис 331