

**Low Voltage SPST 0.8Ω Analog Switch**

**Features**

- ➔ CMOS Technology for Bus and Analog Applications
- ➔ Low On-Resistance: 0.8Ω at 3.0V
- ➔ Wide V<sub>CC</sub> Range: 1.65V to 5.5V
- ➔ Rail-to-Rail Signal Range
- ➔ Control Input Overvoltage Tolerance: 5.5V
- ➔ Fast Transition Speed: 2ns at 5.0V
- ➔ High Bandwidth: 200MHz
- ➔ Extended Industrial Temperature Range: -40°C to 85°C
- ➔ I/O pins Has Power-off Protection Function
- ➔ Totally Lead-Free & Fully RoHS Compliant (Notes 1 & 2)
- ➔ Halogen and Antimony Free. "Green" Device (Note 3)
- ➔ Packaging (Pb-free & Green):
  - ◆ 5-pin SOT23
  - ◆ 5-pin SC70

**Applications**

- ➔ Cell Phones
- ➔ PDAs
- ➔ Portable Instrumentation
- ➔ Battery powered Communications
- ➔ Computer Peripherals

**Pin Configuration**

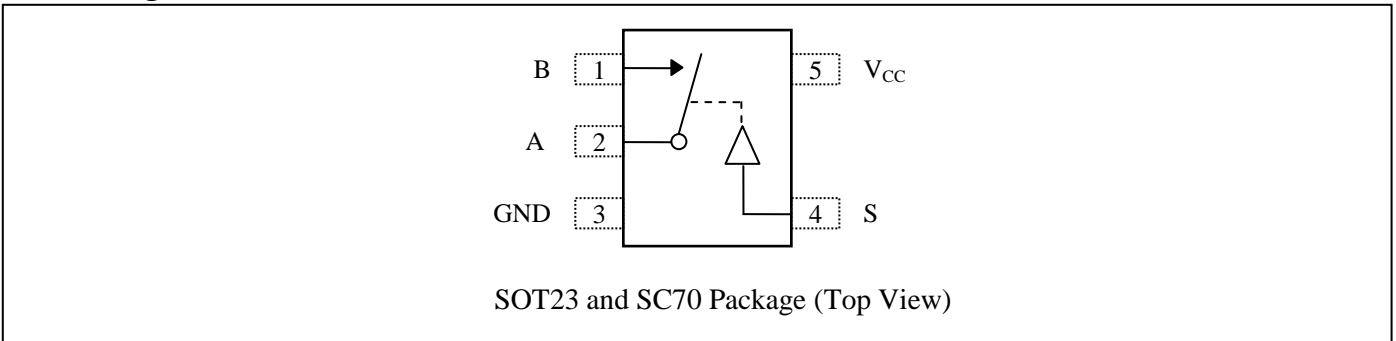

**Pin Description**

Pin No	Pin Name	Description
1	B	Data Port
2	A	Common Output/Data Port
3	GND	Ground
4	S	Logic Control
5	VCC	Positive Power Supply

**Logic Function Table**

Logic Input(S)	Function(A to B)
0	OFF
1	ON

Notes:

1. No purposely added lead. Fully EU Directive 2002/95/EC (RoHS), 2011/65/EU (RoHS 2) & 2015/863/EU (RoHS 3) compliant.
2. See <https://www.diodes.com/quality/lead-free/> for more information about Diodes Incorporated's definitions of Halogen- and Antimony-free, "Green" and Lead-free.
3. Halogen- and Antimony-free "Green" products are defined as those which contain <900ppm bromine, <900ppm chlorine (<1500ppm total Br + Cl) and <1000ppm antimony compounds.

## Maximum Ratings

Storage Temperature.....	-65°C to +150°C
Ambient Temperature with Power Applied.....	-40°C to +85°C
Supply Voltage V <sub>CC</sub> .....	-0.5V to +7.0V
DC Switch Voltage V <sub>S</sub> .....	-0.5V to +7.0V
DC Input Voltage V <sub>IN</sub> .....	-0.5V to +7.0V
DC Output Current V <sub>OUT</sub> .....	128mA
DC V <sub>CC</sub> or Ground Current I <sub>CC</sub> / I <sub>GND</sub> .....	±100mA
Junction Temperature under Bias (T <sub>J</sub> ).....	150°C
Junction Lead Temperature (T <sub>L</sub> ) (Soldering, 10 seconds).....	260°C
ESD (HBM).....	4KV
Power Dissipation (PD) @ +85°C.....	SOT23 250mW SC70 200mW

**Note:**

Stresses greater than those listed under MAXIMUM RATINGS may cause permanent damage to the device. This is a stress rating only and functional operation of the device at these or any other conditions above those indicated in the operational sections of this specification is not implied. Exposure to absolute maximum rating conditions for extended periods may affect reliability.

## Recommended Operating Conditions

Symbol	Parameter	Conditions	Min.	Typ.	Max.	Unit
V <sub>CC</sub>	Operating Voltage	-	1.65	-	5.5	V
V <sub>IN</sub>	DC Input Voltage	-	0	-	V <sub>CC</sub>	V
V <sub>S</sub>	Switch Input Voltage	-	0	-	5.5	V
V <sub>OUT</sub>	Output Voltage	-	0	-	V <sub>CC</sub>	V
T <sub>A</sub>	Operating Temperature	-	-40	25	85	°C
t <sub>r</sub> , t <sub>f</sub>	Input Rise and Fall Time	Control Input V <sub>CC</sub> = 2.7V to 3.6V	0	-	10	ns/V
		Control Input V <sub>CC</sub> = 4.5V to 5.5V	0	-	5	ns/V

**Note:** Control input must be held HIGH or LOW; it must not float.

## DC Electrical Characteristics

(T<sub>A</sub> = -40°C to 85°C, unless otherwise noted.)

Parameter	Description	Test Conditions	Supply Voltage	Min	Typ	Max	Units
V <sub>IAR</sub>	Analog Input Signal Range	-	V <sub>CC</sub>	0	-	V <sub>CC</sub>	V
R <sub>ON</sub>	ON Resistance <sup>(1)</sup>	I <sub>A</sub> = 100mA, V <sub>B</sub> = 0V	4.5V	-	0.7	1.1	Ω
		I <sub>A</sub> = 100mA, V <sub>B</sub> = 2.4V		-	0.6	1.0	
		I <sub>A</sub> = 100mA, V <sub>B</sub> = 4.5V		-	0.8	1.2	
		I <sub>A</sub> = 100mA, V <sub>B</sub> = 0V	3.0V	-	0.8	1.3	
		I <sub>A</sub> = 100mA, V <sub>B</sub> = 3.0V		-	0.9	1.9	
		I <sub>A</sub> = 100mA, V <sub>B</sub> = 0V	2.3V	-	1.0	1.5	
		I <sub>A</sub> = 100mA, V <sub>B</sub> = 2.3V		-	1.2	1.8	
		I <sub>A</sub> = 100mA, V <sub>B</sub> = 0V	1.65V	-	1.3	1.9	
I <sub>A</sub> = 100mA, V <sub>B</sub> = 1.65V	-	2.0		2.8			
R <sub>ONF</sub>	ON Resistance Flatness <sup>(2)</sup>	I <sub>A</sub> = 100mA, V <sub>B</sub> = 0V, 2.4V, 4.5V	4.5V	-	0.2	0.4	Ω
		I <sub>A</sub> = 100mA, V <sub>B</sub> = 0V, 1.5V, 3.3V	3.3V	-	0.2	0.4	
		I <sub>A</sub> = 100mA, V <sub>B</sub> = 0V, 1.1V, 2.5V	2.5V	-	0.4	0.6	
		I <sub>A</sub> = 100mA, V <sub>B</sub> = 0V, 0.7V, 1.8V	1.8V	-	1.0	1.4	
V <sub>IH</sub>	Input High Voltage	Logic High Level	V <sub>CC</sub> = 1.65V	1	-	-	V
			V <sub>CC</sub> = 2.3V	1.2	-	-	
			V <sub>CC</sub> = 3V	1.3	-	-	
			V <sub>CC</sub> = 4.2V	1.5	-	-	
			V <sub>CC</sub> = 5.5V	1.8	-	-	

$V_{IL}$	Input Low Voltage	Logic Low Level	$V_{CC} = 1.65V$	-	-	0.4	V
			$V_{CC} = 2.3V$	-	-	0.6	
			$V_{CC} = 3V$	-	-	0.8	
			$V_{CC} = 4.2V$	-	-	1	
			$V_{CC} = 5.5V$	-	-	1.2	
$I_{OFF(B)}$	Source Off Leakage Current	$V_{CC}=5.5V, V_A=1V, 4.5V$ $V_B=1V, 4.5V$	$V_{CC} = 3V$	-20	-	+20	nA
$I_{NC(A,B)}$	Channel On Leakage Current	-	$V_{CC} = 1.65$ to $5.5V$	-40	-	+40	
$I_{PWROFF}$	Input Leakage Current for Power off	$0 \leq V_A \leq 5.5V$ $0 \leq V_B \leq 5.5V$	$V_{CC} = 0V$	-5	-	5	$\mu A$
$I_{CC}$	Quiescent Supply Current	All channels ON or OFF, $V_B = V_{CC}$ or GND, $I_{OUT}=0$	$V_{CC} = 3.6V$	-	0.002	0.1	$\mu A$
			$V_{CC} = 5.5V$	-	0.002	0.1	

**Notes:**

- Measured by voltage drop between A and B pins at the indicated current through the device. ON resistance is determined by the lower of the voltages on two ports (A or B).
- Flatness is defined as difference between maximum and minimum value of ON resistance over the specified range of conditions. Guaranteed by design.

**Capacitance<sup>(1)</sup>**

Symbol	Parameter	Test Conditions	Min.	Typ.	Max.	Units
$C_{IN}$	Control Input	$V_{CC} = 5.0V, f = 1 \text{ MHz}, T_A = 25^\circ C$	-	3.5	-	pF
$C_{IO-B}$	For B Port, Switch OFF		-	15.0	-	
$C_{IOA-ON}$	For A Port, Switch ON		-	34.0	-	

**Notes:**

- Capacitance is characterized but not tested in production

**Switch and AC Characteristics<sup>(1)</sup>**

Parameter	Description	Test Conditions	Supply Voltage	Min	Typ	Max	Units
$t_{ON}$	Turn on Time	See Figure 1	$V_{CC} = 2.7V$ to $3.6V$	-	3	-	ns
			$V_{CC} = 4.5V$ to $5.5V$	-	2	-	
$t_{OFF}$	Turn off Time	See Figure 1	$V_{CC} = 2.7V$ to $3.6V$	-	9	-	ns
			$V_{CC} = 4.5V$ to $5.5V$	-	5	-	
Q	Charge Injection	$C_L = 1nF, V_{GEN} = 0V,$ $R_{GEN} = 0\Omega.$ See Figure 2	$V_{CC} = 5.0V$	-	35	-	pC
			$V_{CC} = 3.3V$	-	25	-	
$O_{IRR}$	Off Isolation	$R_L = 50\Omega, V_{GEN} = 0V,$ $R_{GEN} = 0\Omega, f = 1MHz.$ See Figure 3 <sup>(2)</sup>	$V_{CC} = 1.65V$ to $5.5V$	-	-70	-	dB
$f_{3dB}$	-3dB Bandwidth	See Figure 6	$V_{CC} = 1.65V$ to $5.5V$	-	200	-	MHz
$T_{HD}$	Total Harmonic Distortion	$R_L = 600\Omega, V_{IN} = 0.5V_{pp}, f = 20Hz$ to 20kHz See Figure 7	$V_{CC} = 2.7V$ to $4.2V$	-	0.015	-	%

**Notes:**

- Guaranteed by design.
- Off Isolation =  $20 \text{ Log}_{10}[V_B/V_A]$  and is measured in dB.

**Test Circuits and Timing Diagrams**

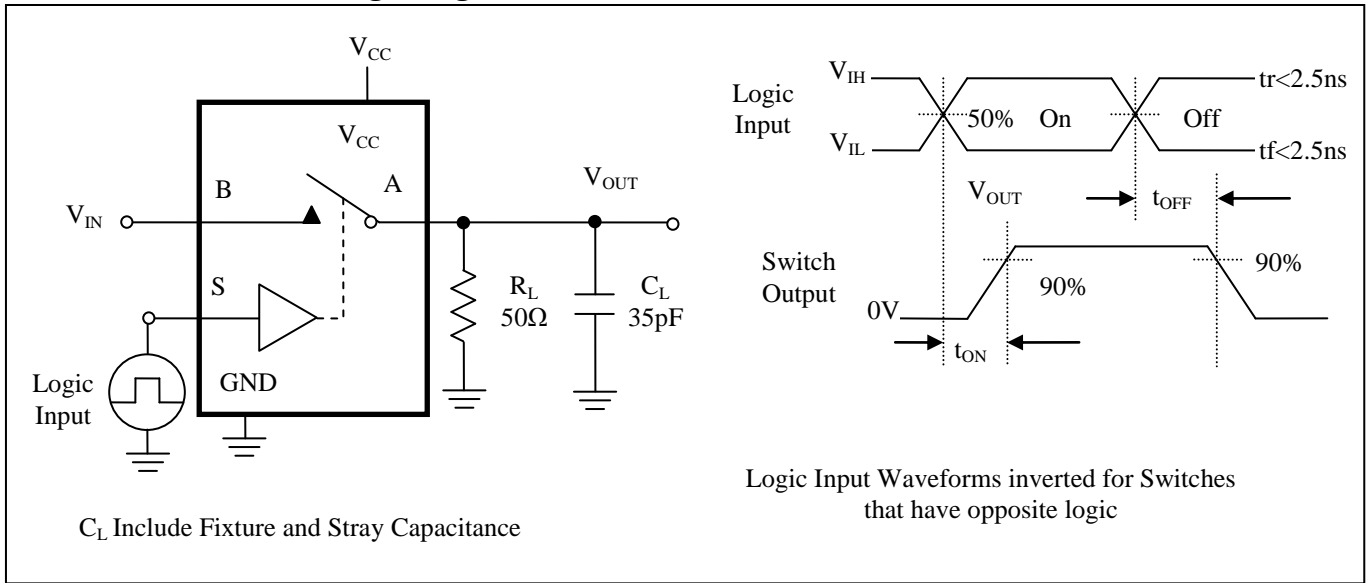

**Figure 1. Turn ON/OFF Timing**

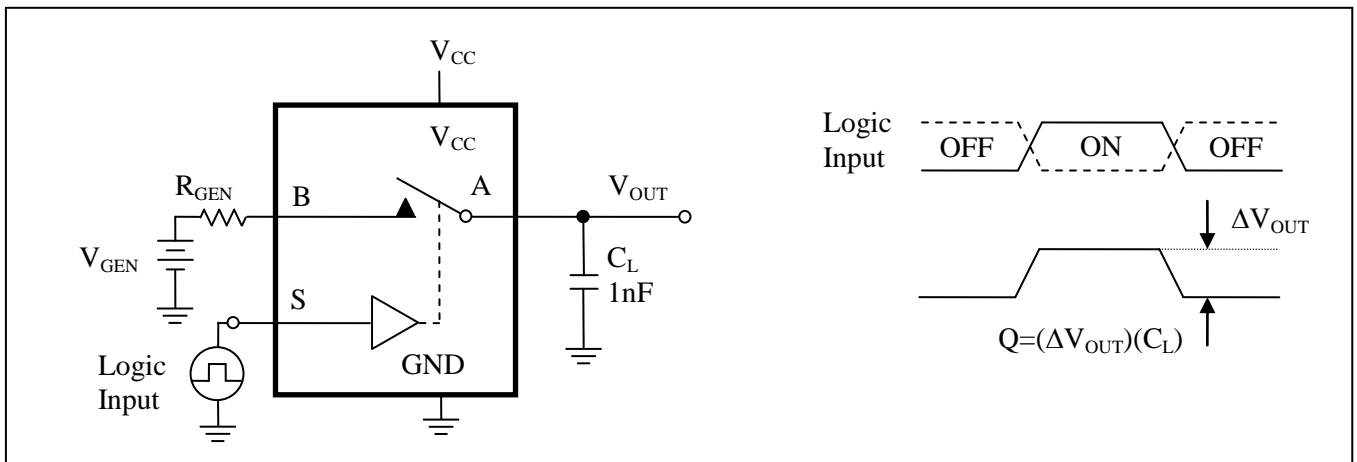

**Figure 2. Charge Injection Test**

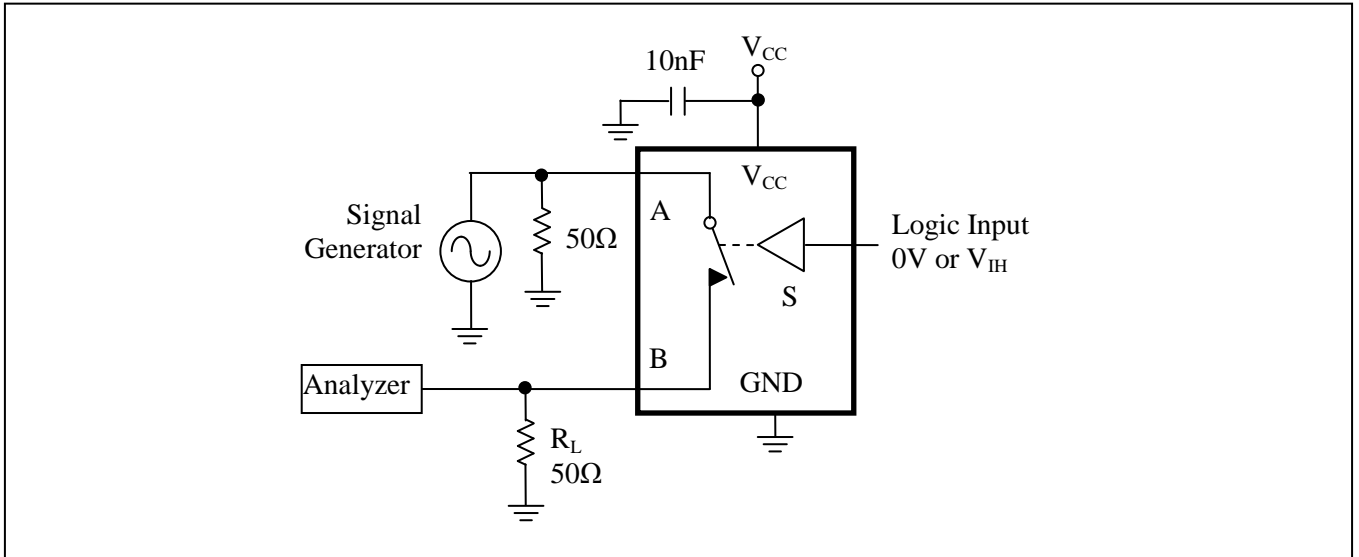

Figure 3. Off Isolation

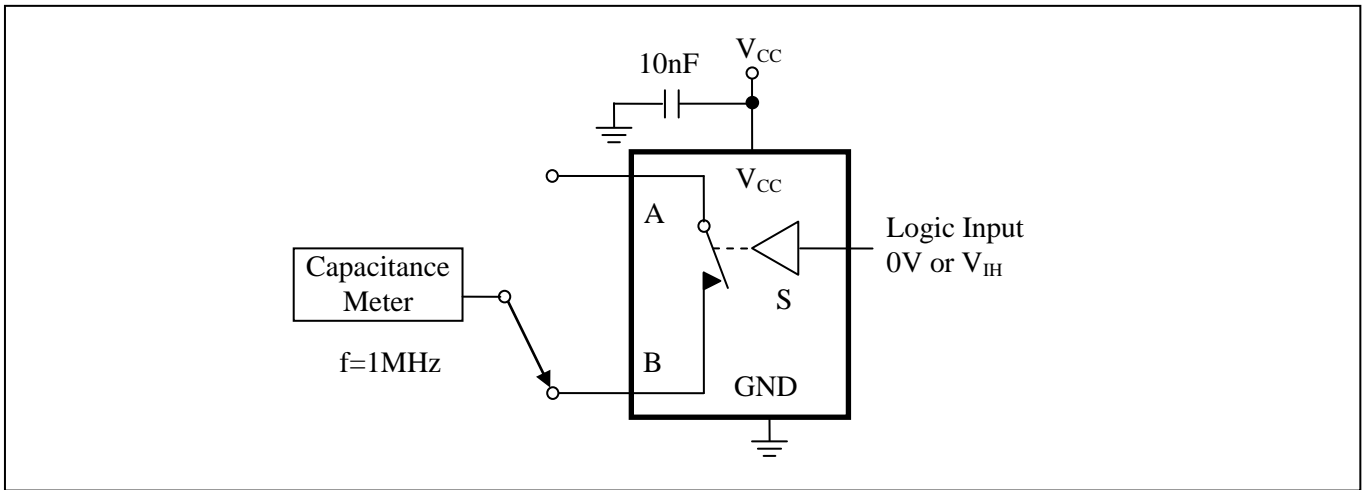

Figure 4. Channel Off Capacitance

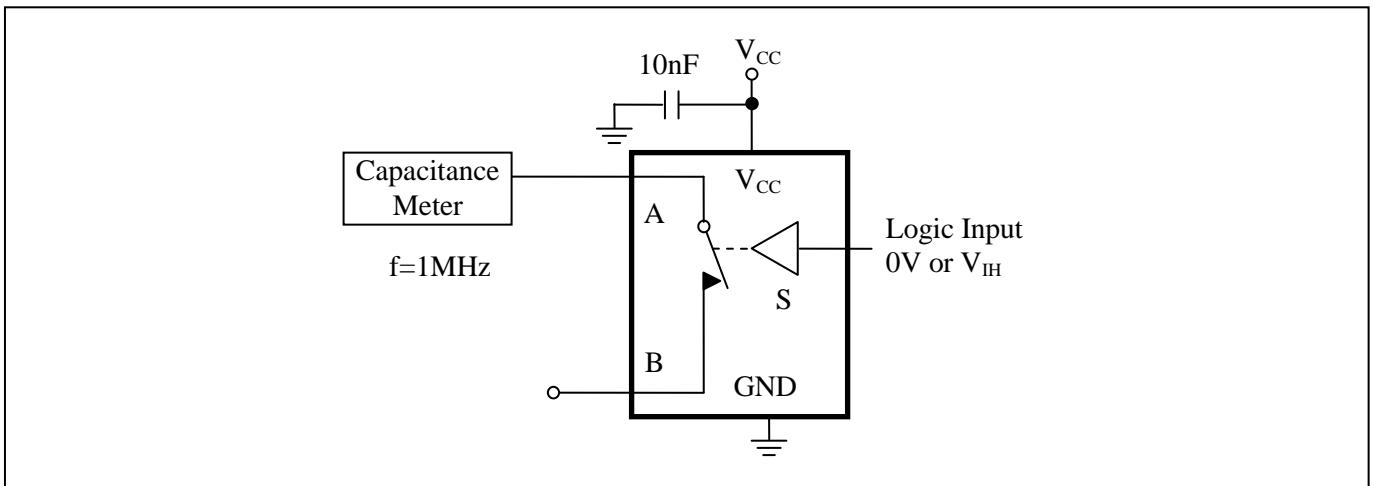

Figure 5. Channel On Capacitance

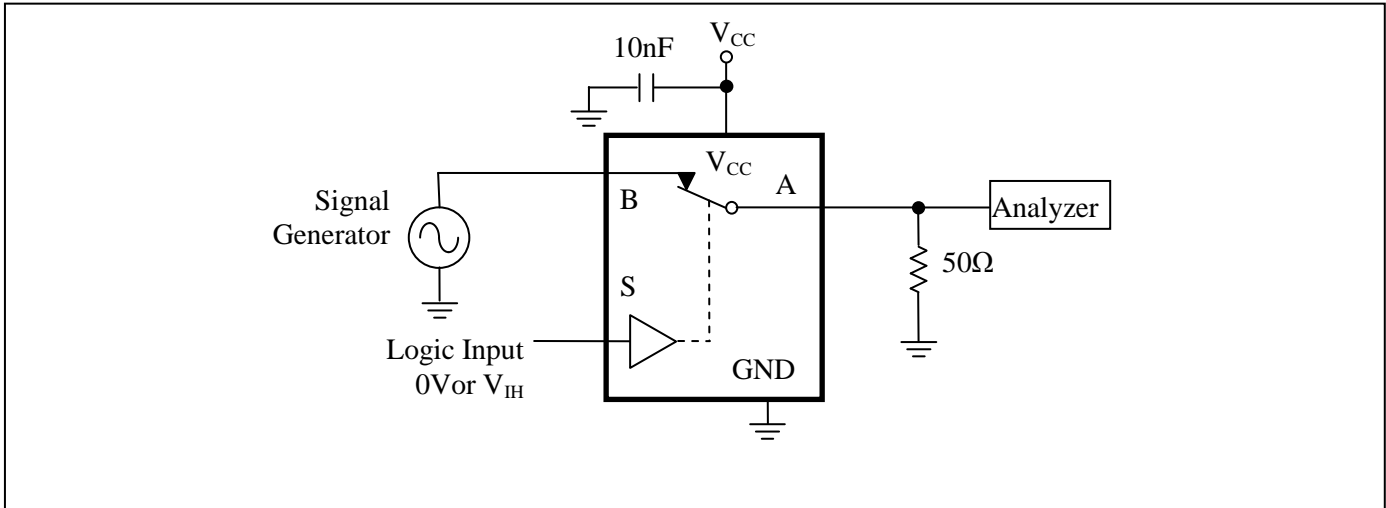

Figure 6. Bandwidth

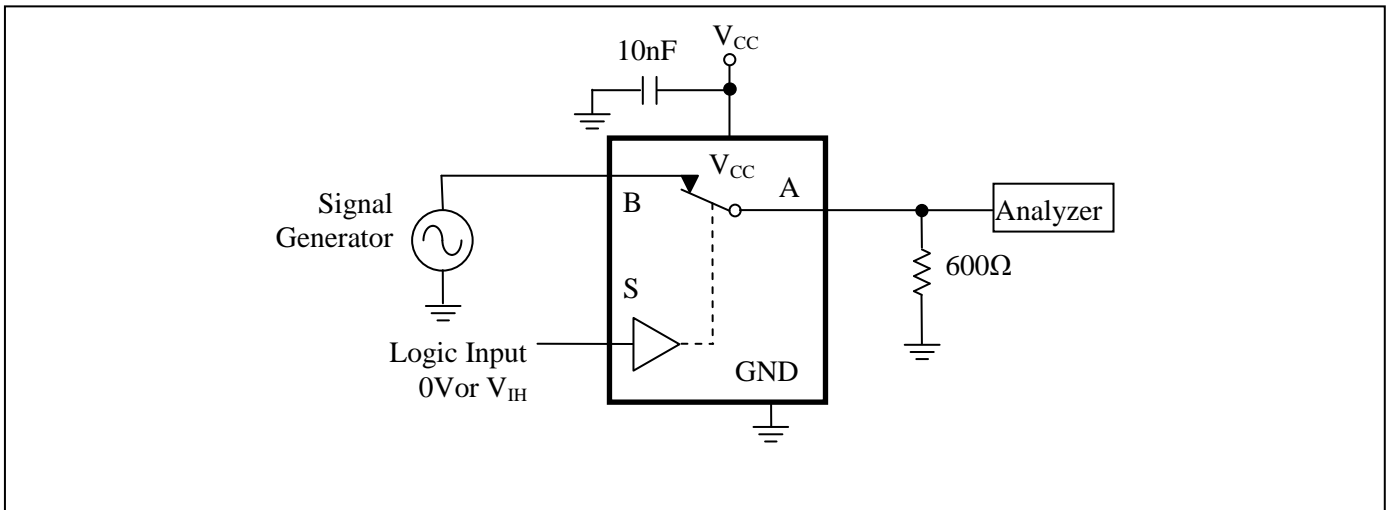
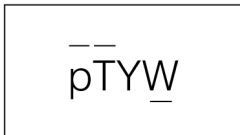

Figure 7. Harmonic Distortion

**Part Marking**

TA Package

pT: PI5A3166TAE



Y: Year  
W: Workweek  
Bar above "T" means Fab3 of MGN

C Package

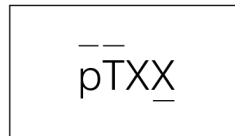

pT: Top Mark  
XX: Date Code (Year & Work Week)  
Bar above "T" means Fab3 of MGN

**Packaging Mechanical**  
SOT23-5 (TA)

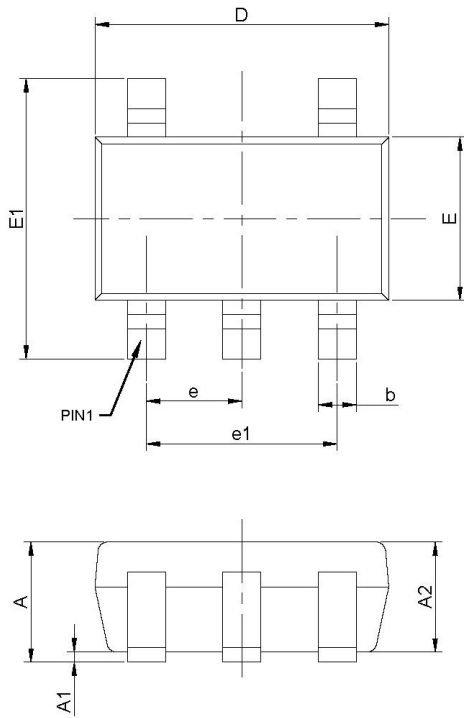

PKG. DIMENSIONS(MM)		
SYMBOL	Min	Max
A	-	1.45
A1	0.00	0.15
A2	0.90	1.30
b	0.30	0.50
c	0.08	0.22
D	2.75	3.05
E	1.45	1.75
E1	2.60	3.00
e	0.95 BSC	
e1	1.90 BSC	
L	0.30	0.60
θ	0°	8°

**Note:**

1. Ref. JEDEC MO-178C/AA
2. PACKAGE OUTLINE DIMENSIONS DO NOT INCLUDE MOLD FLASH AND METAL BUR



DATE: 03/29/16

DESCRIPTION: 5-Pin, Small Outline Transistor Plastic Package (SOT23)

PACKAGE CODE: TA (TA5)

DOCUMENT CONTROL #: PD-2144

REVISION: A

16-0081

**SC70-5 (C)**

PKG. DIMENSIONS(MM)		
SYMBOL	Min	Max
A	-	1.10
A1	0.00	0.10
A2	0.70	1.00
b	0.15	0.30
c	0.08	0.22
D	1.80	2.20
E	1.10	1.40
E1	1.80	2.40
e	0.65 BSC	
e1	1.30 BSC	
L	0.26	0.46
θ	0°	8°

**Notes:**  
 1. Comply with MO-203C/AA, except D Min and D Max  
 2. PACKAGE OUTLINE DIMENSIONS DO NOT INCLUDE MOLD FLASH AND METAL BUR

		DATE: 03/29/16
DESCRIPTION: 5-Pin, SOT353 (SC70)		
PACKAGE CODE: C (C5)		
DOCUMENT CONTROL#: PD-1901	REVISION: E	

16-0091

For latest package information:

Please see <http://www.diodes.com/design/support/packaging/pericom-packaging/packaging-mechanicals-and-thermal-characteristics/>.

**Ordering Information**

Part Number	Package Code	Description
PI5A3166CEX	C	5-Pin, SOT353 (SC70)
PI5A3166TAEX	TA	5-Pin, Small Outline Transistor Plastic Package (SOT23)

**Notes:**

- No purposely added lead. Fully EU Directive 2002/95/EC (RoHS), 2011/65/EU (RoHS 2) & 2015/863/EU (RoHS 3) compliant.
- See <https://www.diodes.com/quality/lead-free/> for more information about Diodes Incorporated's definitions of Halogen- and Antimony-free, "Green" and Lead free.
- Halogen- and Antimony-free "Green" products are defined as those which contain <900ppm bromine, <900ppm chlorine (<1500ppm total Br + Cl) and <1000ppm antimony compounds.
- E = Pb-free and Green
- X suffix = Tape/Reel



#### IMPORTANT NOTICE

DIODES INCORPORATED MAKES NO WARRANTY OF ANY KIND, EXPRESS OR IMPLIED, WITH REGARDS TO THIS DOCUMENT, INCLUDING, BUT NOT LIMITED TO, THE IMPLIED WARRANTIES OF MERCHANTABILITY AND FITNESS FOR A PARTICULAR PURPOSE (AND THEIR EQUIVALENTS UNDER THE LAWS OF ANY JURISDICTION).

Diodes Incorporated and its subsidiaries reserve the right to make modifications, enhancements, improvements, corrections or other changes without further notice to this document and any product described herein. Diodes Incorporated does not assume any liability arising out of the application or use of this document or any product described herein; neither does Diodes Incorporated convey any license under its patent or trademark rights, nor the rights of others. Any Customer or user of this document or products described herein in such applications shall assume all risks of such use and will agree to hold Diodes Incorporated and all the companies whose products are represented on Diodes Incorporated website, harmless against all damages.

Diodes Incorporated does not warrant or accept any liability whatsoever in respect of any products purchased through unauthorized sales channel.

Should Customers purchase or use Diodes Incorporated products for any unintended or unauthorized application, Customers shall indemnify and hold Diodes Incorporated and its representatives harmless against all claims, damages, expenses, and attorney fees arising out of, directly or indirectly, any claim of personal injury or death associated with such unintended or unauthorized application.

Products described herein may be covered by one or more United States, international or foreign patents pending. Product names and markings noted herein may also be covered by one or more United States, international or foreign trademarks.

This document is written in English but may be translated into multiple languages for reference. Only the English version of this document is the final and determinative format released by Diodes Incorporated.

#### LIFE SUPPORT

Diodes Incorporated products are specifically not authorized for use as critical components in life support devices or systems without the express written approval of the Chief Executive Officer of Diodes Incorporated. As used herein:

- A. Life support devices or systems are devices or systems which:
  - 1. are intended to implant into the body, or
  - 2. support or sustain life and whose failure to perform when properly used in accordance with instructions for use provided in the labeling can be reasonably expected to result in significant injury to the user.
- B. A critical component is any component in a life support device or system whose failure to perform can be reasonably expected to cause the failure of the life support device or to affect its safety or effectiveness.

Customers represent that they have all necessary expertise in the safety and regulatory ramifications of their life support devices or systems, and acknowledge and agree that they are solely responsible for all legal, regulatory and safety-related requirements concerning their products and any use of Diodes Incorporated products in such safety-critical, life support devices or systems, notwithstanding any devices- or systems-related information or support that may be provided by Diodes Incorporated. Further, Customers must fully indemnify Diodes Incorporated and its representatives against any damages arising out of the use of Diodes Incorporated products in such safety-critical, life support devices or systems.

Copyright © 2018, Diodes Incorporated  
www.diodes.com



## Стандарт Электрон Связь

Мы молодая и активно развивающаяся компания в области поставок электронных компонентов. Мы поставляем электронные компоненты отечественного и импортного производства напрямую от производителей и с крупнейших складов мира.

Благодаря сотрудничеству с мировыми поставщиками мы осуществляем комплексные и плановые поставки широчайшего спектра электронных компонентов.

Собственная эффективная логистика и склад в обеспечивает надежную поставку продукции в точно указанные сроки по всей России.

Мы осуществляем техническую поддержку нашим клиентам и предпродажную проверку качества продукции. На все поставляемые продукты мы предоставляем гарантию .

Осуществляем поставки продукции под контролем ВП МО РФ на предприятия военно-промышленного комплекса России , а также работаем в рамках 275 ФЗ с открытием отдельных счетов в уполномоченном банке. Система менеджмента качества компании соответствует требованиям ГОСТ ISO 9001.

Минимальные сроки поставки, гибкие цены, неограниченный ассортимент и индивидуальный подход к клиентам являются основой для выстраивания долгосрочного и эффективного сотрудничества с предприятиями радиоэлектронной промышленности, предприятиями ВПК и научно-исследовательскими институтами России.

С нами вы становитесь еще успешнее!

### Наши контакты:

**Телефон:** +7 812 627 14 35

**Электронная почта:** [sales@st-electron.ru](mailto:sales@st-electron.ru)

**Адрес:** 198099, Санкт-Петербург,  
Промышленная ул, дом № 19, литера Н,  
помещение 100-Н Офис 331