



EFC6604R

N-Channel Power MOSFET 12V, 13A, 9.0mΩ, Dual EFCP

ON Semiconductor®
<http://onsemi.com>

Features

- 2.5V drive
- Common-drain type
- 2KV ESD HBM
- Protection diode in
- Halogen free compliance

Applications

- Lithium-ion battery charging and discharging switch

Specifications

Absolute Maximum Ratings at $T_a = 25^\circ\text{C}$

Parameter	Symbol	Conditions	Ratings	Unit
Source to Source Voltage	V_{SSS}		12	V
Gate to Source Voltage	V_{GSS}		± 12	V
Source Current (DC)	I_S		13	A
Source Current (Pulse)	I_{SP}	$PW \leq 10\mu\text{s}$, duty cycle $\leq 1\%$	60	A
Total Dissipation	P_T	When mounted on ceramic substrate (5000mm ² ×0.8mm)	1.6	W
Channel Temperature	T_{ch}		150	°C
Storage Temperature	T_{stg}		-55 to +150	°C

Stresses exceeding Maximum Ratings may damage the device. Maximum Ratings are stress ratings only. Functional operation above the Recommended Operating Conditions is not implied. Extended exposure to stresses above the Recommended Operating Conditions may affect device reliability.

Electrical Characteristics at $T_a = 25^\circ\text{C}$

Parameter	Symbol	Conditions	Ratings			Unit
			min	typ	max	
Source to Source Breakdown Voltage	$V_{(BR)SSS}$	$I_S=1\text{mA}$, $V_{GS}=0\text{V}$ Test Circuit 1	12			V
Zero-Gate Voltage Source Current	I_{SSS}	$V_{SS}=10\text{V}$, $V_{GS}=0\text{V}$ Test Circuit 1			1	μA
Gate to Source Leakage Current	I_{GSS}	$V_{GS}=\pm 8\text{V}$, $V_{SS}=0\text{V}$ Test Circuit 2			± 1.0	μA
Cutoff Voltage	$V_{GS(off)}$	$V_{SS}=6\text{V}$, $I_S=1\text{mA}$ Test Circuit 3	0.5		1.3	V
Forward Transfer Admittance	$ y_{fs} $	$V_{SS}=6\text{V}$, $I_S=3\text{A}$ Test Circuit 4		13.7		S
Static Source to Source On-State Resistance	$R_{SS(on)1}$	$I_S=3\text{A}$, $V_{GS}=4.5\text{V}$ Test Circuit 5	6.0	7.5	9.0	$\text{m}\Omega$
	$R_{SS(on)2}$	$I_S=3\text{A}$, $V_{GS}=4.0\text{V}$ Test Circuit 5	6.4	8.1	9.7	$\text{m}\Omega$
	$R_{SS(on)3}$	$I_S=3\text{A}$, $V_{GS}=3.8\text{V}$ Test Circuit 5	6.7	8.4	10.0	$\text{m}\Omega$
	$R_{SS(on)4}$	$I_S=3\text{A}$, $V_{GS}=3.1\text{V}$ Test Circuit 5	7.8	9.8	12.7	$\text{m}\Omega$
	$R_{SS(on)5}$	$I_S=3\text{A}$, $V_{GS}=2.5\text{V}$ Test Circuit 5	10.0	12.6	17.7	$\text{m}\Omega$
Turn-ON Delay Time	$t_d(on)$	$V_{SS}=6\text{V}$, $V_{GS}=4.5\text{V}$, $I_S=3\text{A}$ Test Circuit 6		300		ns
Rise Time	t_r			1200		ns
Turn-OFF Delay Time	$t_d(off)$			5200		ns
Fall Time	t_f			3900		ns
Total Gate Charge	Q_g	$V_{SS}=6\text{V}$, $V_{GS}=4.5\text{V}$, $I_S=13\text{A}$ Test Circuit 7		29		nC
Forward Source to Source Voltage	$V_{F(S-S)}$	$I_S=3\text{A}$, $V_{GS}=0\text{V}$ Test Circuit 8		0.75	1.2	V

ORDERING INFORMATION

See detailed ordering and shipping information on page 5 of this data sheet.

Test circuits are example of measuring FET1 side

Test Circuit 1
I_{SSS}

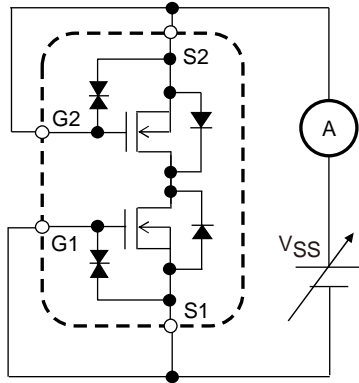

Test Circuit 2
I_{GSS}

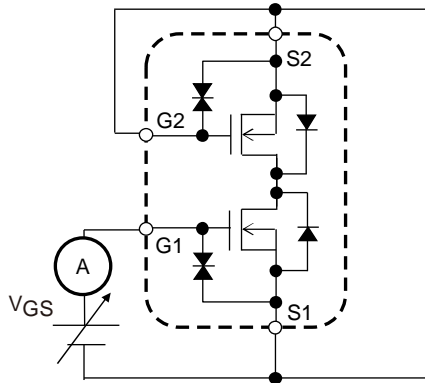

When FET1 is measured, Gate and Source of FET2 are short-circuited.

Test Circuit 3
V_{GS(off)}

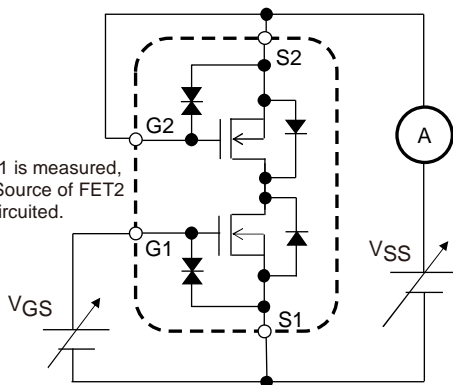

When FET1 is measured, Gate and Source of FET2 are short-circuited.

Test Circuit 4
|y_{fs}|

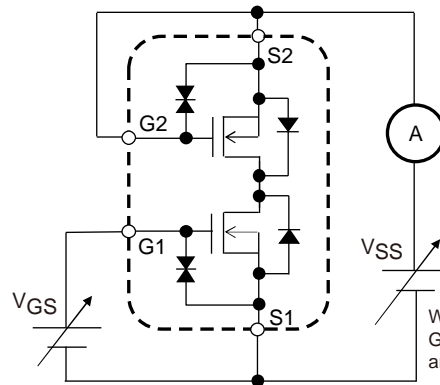

When FET1 is measured, Gate and Source of FET2 are short-circuited.

Test Circuit 5
R_{SS(on)}

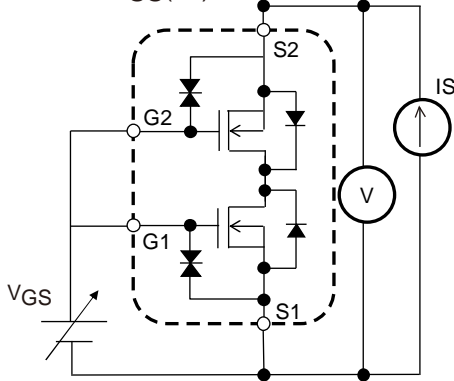

Test Circuit 6
t_{d(on)}, t_r, t_{d(off)}, t_f

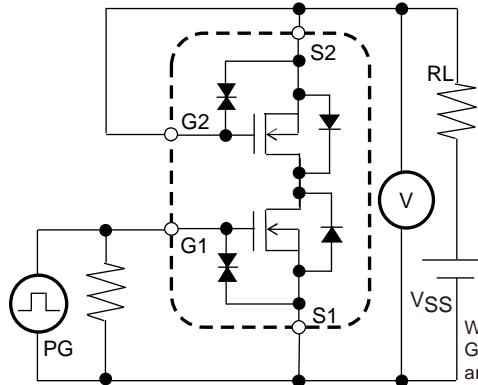

When FET1 is measured, Gate and Source of FET2 are short-circuited.

Test Circuit 7
Q_g

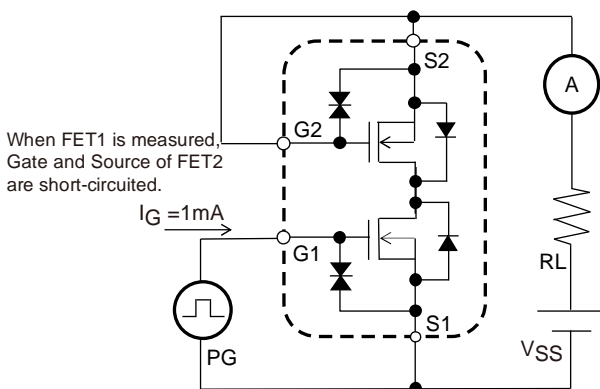

When FET1 is measured, Gate and Source of FET2 are short-circuited.

Test Circuit 8
V_{F(S-S)}

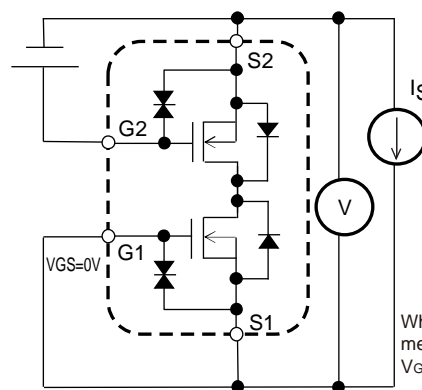

When FET1 is measured, +4.5V is added to V_{GS} of FET2.

EFC6604R

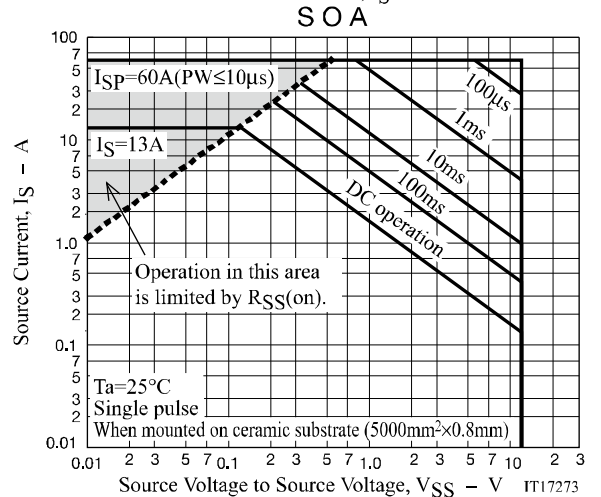
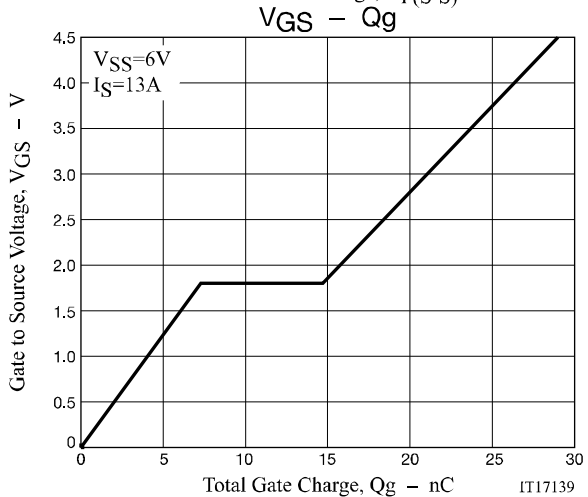
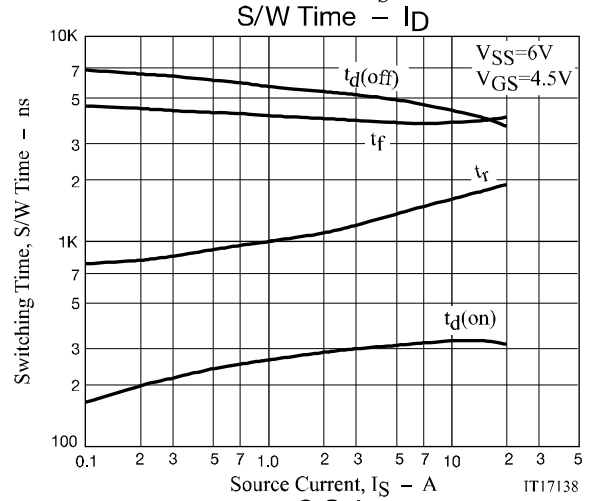
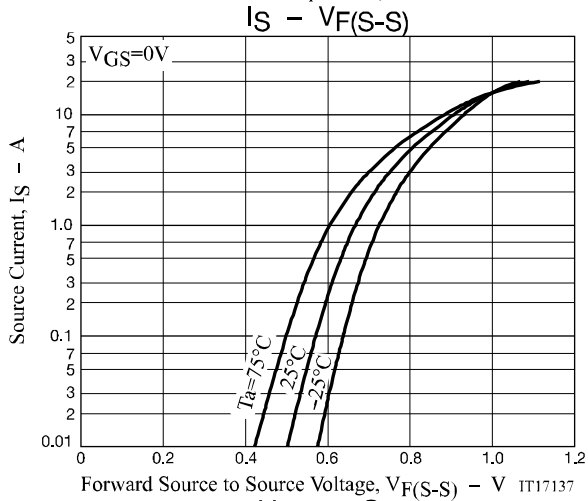
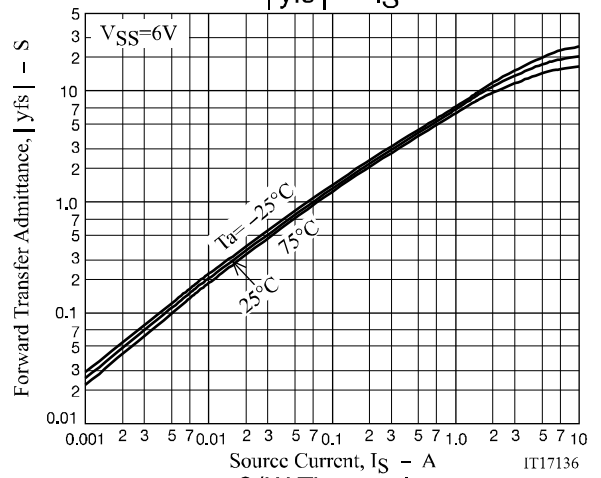
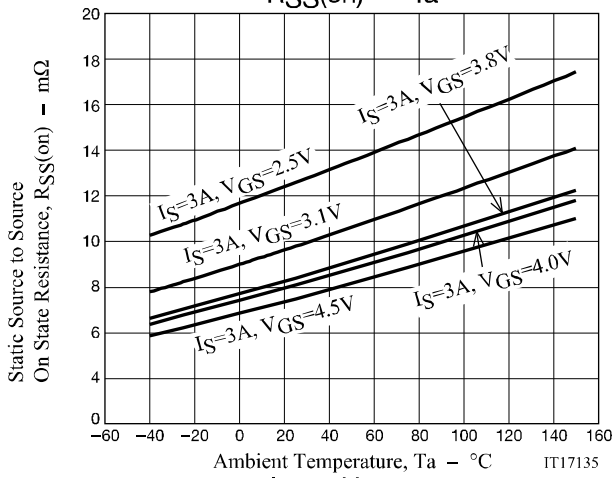
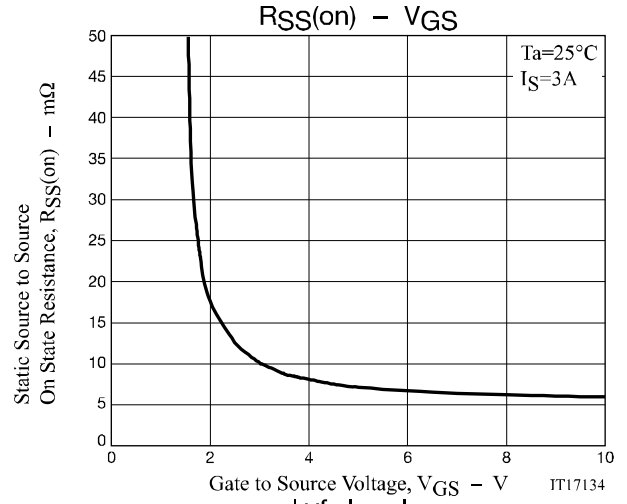
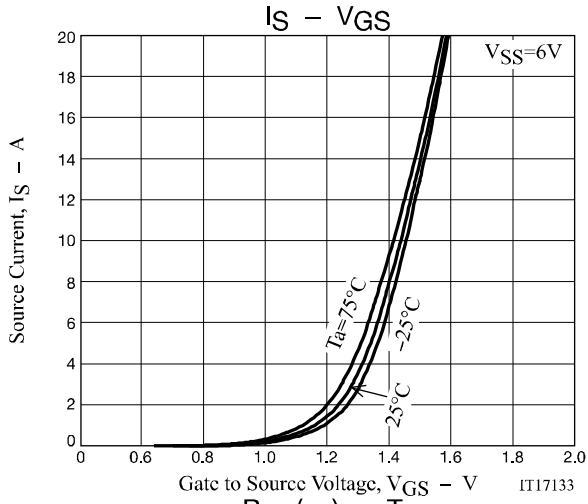

EFC6604R

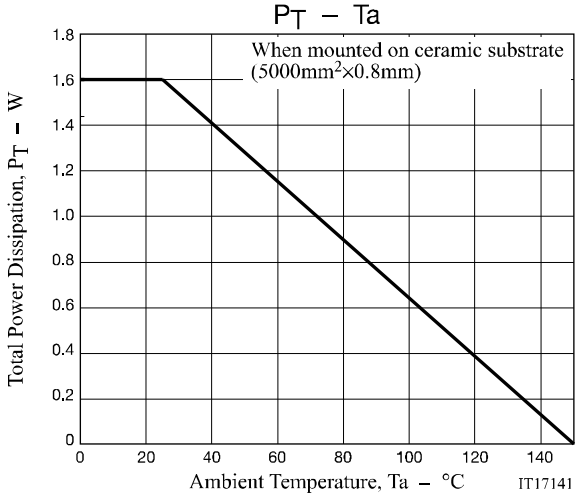

EFC6604R

Package Dimensions

EFC6604R-TR

EFCP1915-6CE-020

Unit : mm

- 1: Source1
- 2: Gate1
- 3: Source1
- 4: Source2
- 5: Gate2
- 6: Source2

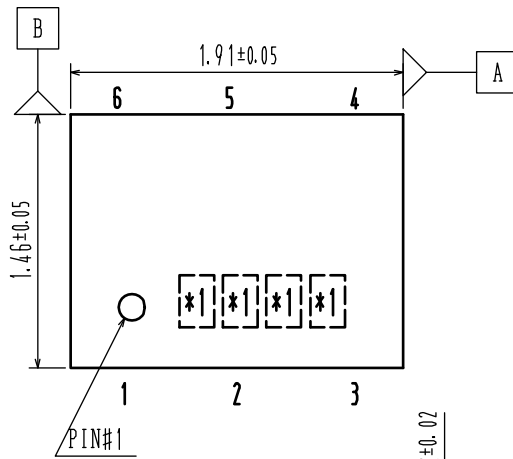

Land Pattern Example

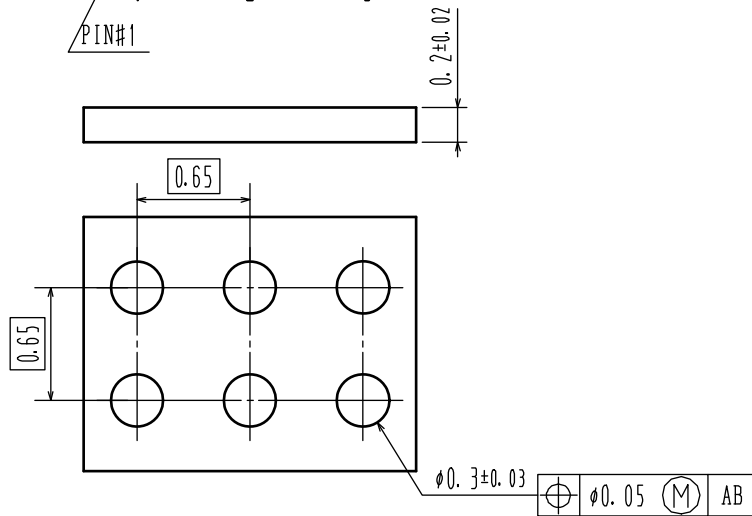
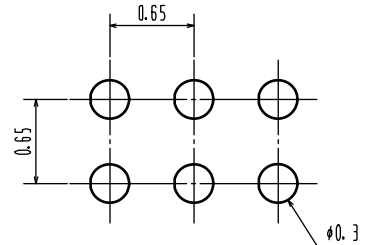

*1: Lot indication

Ordering & Package Information

Device	Package	Shipping	note
EFC6604R-TR	EFCP	5,000 pcs. / reel	Pb-Free and Halogen Free

Packing Type: TR

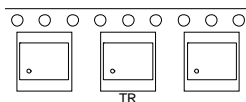

Marking

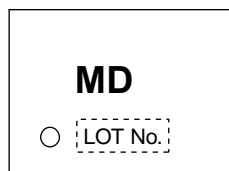

Electrical Connection

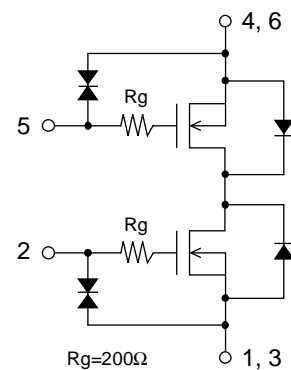

Note on usage : Since the EFC6604R is a MOSFET product, please avoid using this device in the vicinity of highly charged objects.

ON Semiconductor and the ON logo are registered trademarks of Semiconductor Components Industries, LLC (SCILLC). SCILLC owns the rights to a number of patents, trademarks, copyrights, trade secrets, and other intellectual property. A listing of SCILLC's product/patent coverage may be accessed at www.onsemi.com/site/pdf/Patent-Marking.pdf. SCILLC reserves the right to make changes without further notice to any products herein. SCILLC makes no warranty, representation or guarantee regarding the suitability of its products for any particular purpose, nor does SCILLC assume any liability arising out of the application or use of any product or circuit, and specifically disclaims any and all liability, including without limitation special, consequential or incidental damages. "Typical" parameters which may be provided in SCILLC data sheets and/or specifications can and do vary in different applications and actual performance may vary over time. All operating parameters, including "Typicals" must be validated for each customer application by customer's technical experts. SCILLC does not convey any license under its patent rights nor the rights of others. SCILLC products are not designed, intended, or authorized for use as components in systems intended for surgical implant into the body, or other applications intended to support or sustain life, or for any other application in which the failure of the SCILLC product could create a situation where personal injury or death may occur. Should Buyer purchase or use SCILLC products for any such unintended or unauthorized application, Buyer shall indemnify and hold SCILLC and its officers, employees, subsidiaries, affiliates, and distributors harmless against all claims, costs, damages, and expenses, and reasonable attorney fees arising out of, directly or indirectly, any claim of personal injury or death associated with such unintended or unauthorized use, even if such claim alleges that SCILLC was negligent regarding the design or manufacture of the part. SCILLC is an Equal Opportunity/Affirmative Action Employer. This literature is subject to all applicable copyright laws and is not for resale in any manner.



Стандарт Электрон Связь

Мы молодая и активно развивающаяся компания в области поставок электронных компонентов. Мы поставляем электронные компоненты отечественного и импортного производства напрямую от производителей и с крупнейших складов мира.

Благодаря сотрудничеству с мировыми поставщиками мы осуществляем комплексные и плановые поставки широчайшего спектра электронных компонентов.

Собственная эффективная логистика и склад в обеспечивает надежную поставку продукции в точно указанные сроки по всей России.

Мы осуществляем техническую поддержку нашим клиентам и предпродажную проверку качества продукции. На все поставляемые продукты мы предоставляем гарантию .

Осуществляем поставки продукции под контролем ВП МО РФ на предприятия военно-промышленного комплекса России , а также работаем в рамках 275 ФЗ с открытием отдельных счетов в уполномоченном банке. Система менеджмента качества компании соответствует требованиям ГОСТ ISO 9001.

Минимальные сроки поставки, гибкие цены, неограниченный ассортимент и индивидуальный подход к клиентам являются основой для выстраивания долгосрочного и эффективного сотрудничества с предприятиями радиоэлектронной промышленности, предприятиями ВПК и научно-исследовательскими институтами России.

С нами вы становитесь еще успешнее!

Наши контакты:

Телефон: +7 812 627 14 35

Электронная почта: sales@st-electron.ru

Адрес: 198099, Санкт-Петербург,
Промышленная ул, дом № 19, литера Н,
помещение 100-Н Офис 331