

# ACNV3130

## 2.5 Amp Output Current IGBT Gate Drive Optocoupler in 500Mil DIP10 Package



### Data Sheet

#### Description

The ACNV3130 contains an AlGaAs LED, which is optically coupled to an integrated circuit with a power output stage. This optocoupler is ideally suited for driving power IGBTs and MOSFETs used in motor control inverter applications. The high operating voltage range of the output stage provides the drive voltages required by gate controlled devices. The voltage and high peak output current supplied by this optocoupler can be used to drive a discrete power stage make it ideally suited for direct driving IGBT with ratings up to 1700V/100A. For IGBTs with higher ratings, this optocoupler can be used to drive a discrete power stage which drives the IGBT gate. The ACNV3130 has the highest insulation voltage of VIORM= 2262 Vpeak in the IEC/ EN/DIN EN 60747-5-5.

#### Functional Diagram

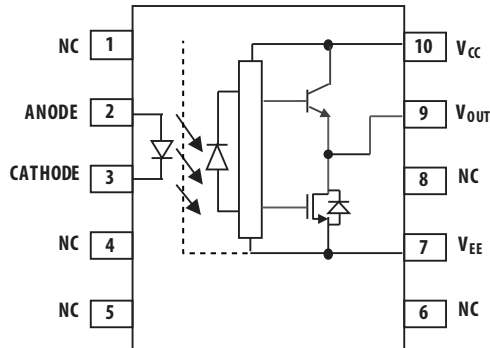

#### Design Note:

- NC denotes not connected
- A 0.1  $\mu$ F bypass capacitor must be connected between pins VCC and VEE

#### Truth Table - ACNV3130

LED	V <sub>CC</sub> - V <sub>EE</sub> "POSITIVE GOING" (i.e., TURN-ON)	V <sub>CC</sub> - V <sub>EE</sub> "NEGATIVE GOING" (i.e., TURN-OFF)	V <sub>O</sub>
OFF	0 - 30 V	0 - 30 V	LOW
ON	0 - 11V	0 - 9.5V	LOW
ON	11 - 13.5V	9.5 - 12V	TRANSITION
ON	13.5 - 30V	12 - 30V	HIGH

#### Features

- 2.5 A maximum peak output current
- 2.0 A minimum peak output current
- 500 ns maximum propagation delay
- 350 ns maximum propagation delay difference
- 40 kV/ $\mu$ s minimum Common Mode Rejection (CMR) at V<sub>CM</sub> = 1500 V
- I<sub>CC</sub> = 5.0 mA maximum supply current
- Under Voltage Lock-Out Protection (UVLO) with Hysteresis
- Wide Operating V<sub>CC</sub> Range: 15 to 30 V
- Industrial Temperature Range: -40°C to 105°C
- Safety Approval Pending
  - UL Recognized 7500 V<sub>RMS</sub> for 1 min.
  - CSA
  - IEC/EN/DIN EN 60747-5-5 V<sub>IORM</sub> = 2262 Vpeak

#### Applications

- 690Vac application
- IGBT/MOSFET gate drive
- AC and Brushless DC motor drives
- Renewable energy inverters
- Industrial inverters
- Switching power supplies

**CAUTION:** It is advised that normal static precautions be taken in handling and assembly of this component to prevent damage and/or degradation which may be induced by ESD.

## Ordering Information

ACNV3130 is UL Recognized with 7500 V<sub>RMS</sub> for 1 minute per UL1577.

Part number	Option RoHS Compliant	Package	Gull Wing Surface Mount	Tape & Reel	IEC/EN/DIN EN 60747-5-5	Quantity
ACNV3130	-000E	500mil			X	35 per tube
	-300E	DIP-10	X		X	35 per tube
	-500E		X	X	X	500 per reel

To order, choose a part number from the part number column and combine with the desired option from the option column to form an order entry.

Example 1:

ACNV3130-500E to order product of 500mil DIP Gull Wing Surface Mount package in Tape and Reel packaging with IEC/EN/DIN EN 60747-5-5 Safety Approval in RoHS compliant.

Example 2:

ACNV3130-000E to order product of 500mil DIP package in Tube packaging and RoHS compliant.

Option datasheets are available. Contact your Avago sales representative or authorized distributor for information.

## Package Outline Drawings

### ACNV3130 Outline Drawing (10-pin Wide Body Package / 500mil DIP)

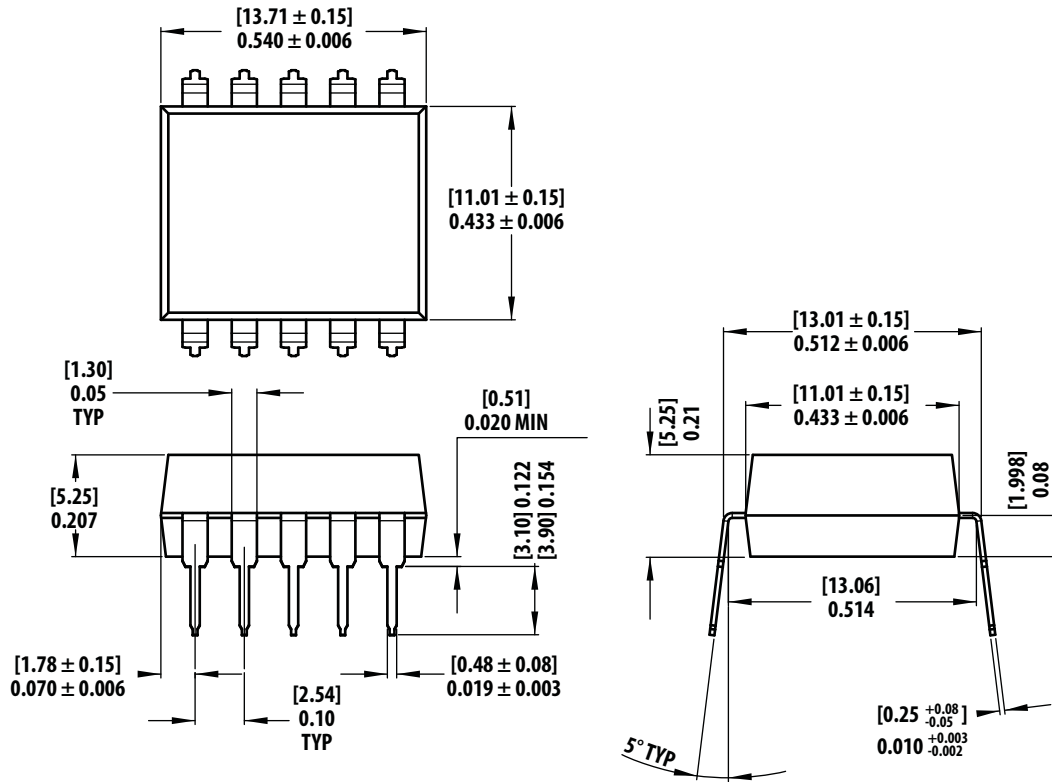

Dimensions in Inches [Millimeters]

### ACNV3130 Gull Wing Surface Mount Option 300 Outline Drawing

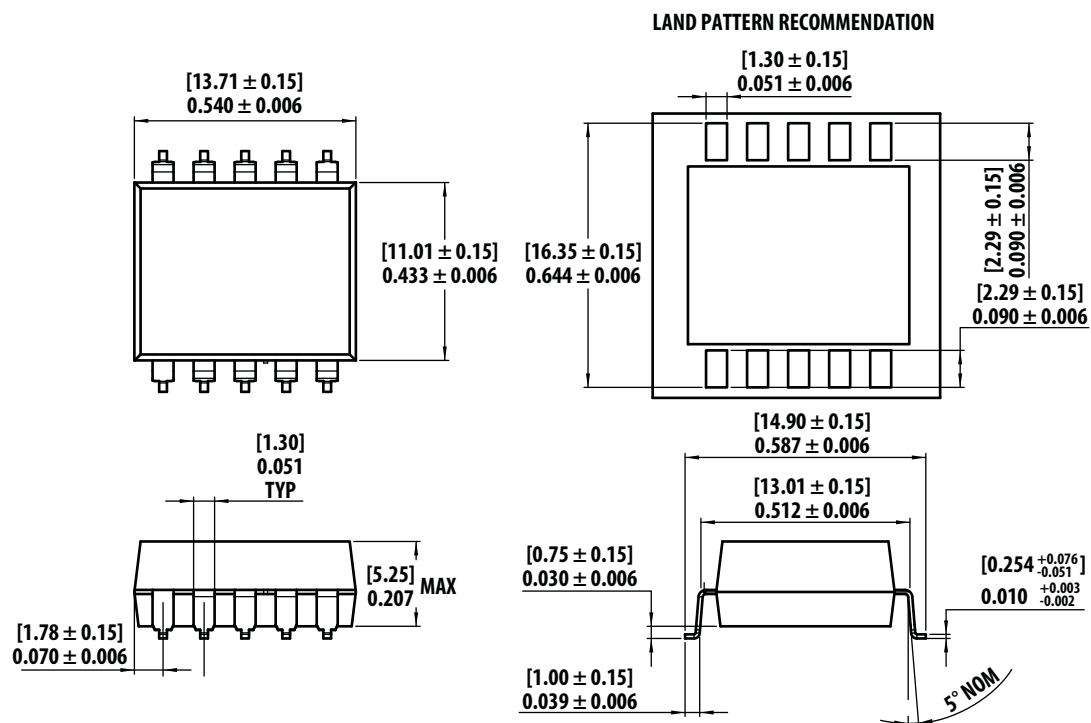

Dimension in Inches [Millimeter]

## Recommended Pb-Free IR Profile

Recommended reflow condition as per JEDEC Standard, J-STD-020 (latest revision). Non- Halide Flux should be used.

## Regulatory Information

The ACNV3130 is pending approval by the following organizations:

### UL

Recognized under UL 1577, component recognition program up to  $V_{ISO} = 7500 V_{RMS}$ , File E55361

### CSA

CSA Component Acceptance Notice #5, File CA 88324

### IEC/EN/DIN EN 60747-5-5

Maximum Working Insulation Voltage  $V_{IORM} = 2262V_{peak}$

**Table 1. IEC/EN/DIN EN 60747-5-5 Insulation Characteristics\***

Description	Symbol	Characteristic	Unit
Installation classification per DIN VDE 0110/39, Table 1 for rated mains voltage $\leq 600 V_{rms}$ for rated mains voltage $\leq 1000 V_{rms}$		I – IV I – IV	
Climatic Classification		55/105/21	
Pollution Degree (DIN VDE 0110/39)		2	
Maximum Working Insulation Voltage	$V_{IORM}$	2262	$V_{peak}$
Input to Output Test Voltage, Method b* $V_{IORM} \times 1.875 = V_{PR}$ , 100% Production Test with $t_m = 1$ sec, Partial discharge $< 5$ pC	$V_{PR}$	4242	$V_{peak}$
Input to Output Test Voltage, Method a* $V_{IORM} \times 1.6 = V_{PR}$ , Type and Sample Test, $t_m = 10$ sec, Partial discharge $< 5$ pC	$V_{PR}$	3619	$V_{peak}$
Highest Allowable Overvoltage* (Transient Overvoltage $t_{ini} = 60$ sec)	$V_{IOTM}$	12000	$V_{peak}$
Safety-limiting values – maximum values allowed in the event of a failure			
Case Temperature	$T_S$	150	$^{\circ}C$
Input Current	$I_{S, INPUT}$	400	mA
Output Power	$P_{S, OUTPUT}$	1	W
Insulation Resistance at $T_S$ , $V_{IO} = 500$ V	$R_S$	$> 10^9$	$\Omega$

\* Refer to the optocoupler section of the Isolation and Control Components Designer's Catalog, under Product Safety Regulations section, (IEC/EN/DIN EN 60747-5-5) for a detailed description of Method a and Method b partial discharge test profiles.

Note: These optocouplers are suitable for "safe electrical isolation" only within the safety limit data. Maintenance of the safety data shall be ensured by means of protective circuits. Surface mount classification is Class A in accordance with CECC 00802.

**Table 2. Insulation and Safety Related Specifications**

Parameter	Symbol	ACNV3130	Units	Conditions
Minimum External Air Gap (Clearance)	L(101)	13.0	mm	Measured from input terminals to output terminals, shortest distance through air.
Minimum External Tracking (Creepage)	L(102)	13.0	mm	Measured from input terminals to output terminals, shortest distance path along body.
Minimum Internal Plastic Gap (Internal Clearance)		1.5	mm	Through insulation distance conductor to conductor, usually the straight line distance thickness between the emitter and detector.
Tracking Resistance (Comparative Tracking Index)	CTI	> 200	V	DIN IEC 112/VDE 0303 Part 1
Isolation Group		IIIa		Material Group (DIN VDE 0110, 1/89, Table 1)

## Notes:

- All Avago data sheets report the creepage and clearance inherent to the optocoupler component itself. These dimensions are needed as a starting point for the equipment designer when determining the circuit insulation requirements. However, once mounted on a printed circuit board, minimum creepage and clearance requirements must be met as specified for individual equipment standards. For creepage, the shortest distance path along the surface of a printed circuit board between the solder fillets of the input and output leads must be considered (the recommended Land Pattern does not necessarily meet the minimum creepage of the device). There are recommended techniques such as grooves and ribs which may be used on a printed circuit board to achieve desired creepage and clearances. Creepage and clearance distances will also change depending on factors such as pollution degree and insulation level.

**Table 3. Absolute Maximum Ratings**

Parameter	Symbol	Min.	Max.	Units	Note
Storage Temperature	$T_S$	-55	125	°C	
Operating Temperature	$T_A$	-40	105	°C	
Average Input Current	$I_{F(AVG)}$		25	mA	1
Peak Transient Input Current (<1 $\mu$ s pulse width, 300pps)	$I_{F(TRAN)}$		1	A	
Reverse Input Voltage	$V_R$		5	V	
“High” Peak Output Current	$I_{OH(PEAK)}$		2.5	A	2
“Low” Peak Output Current	$I_{OL(PEAK)}$		2.5	A	2
Total Output Supply Voltage	$(V_{CC} - V_{EE})$	0	35	V	
Input Current (Rise/Fall Time)	$t_{r(IN)} / t_{f(IN)}$		500	ns	
Output Voltage	$V_{O(PEAK)}$	-0.5	$V_{CC}$	V	
Output IC Power Dissipation	$P_O$		700	mW	3
Total Power Dissipation	$P_T$		745	mW	4

**Table 4. Recommended Operating Conditions**

Parameter	Symbol	Min	Max.	Units	Note
Operating Temperature	$T_A$	- 40	105	°C	
Output Supply Voltage	$(V_{CC} - V_{EE})$	15	30	V	
Input Current (ON)	$I_{F(ON)}$	12	16	mA	
Input Voltage (OFF)	$V_{F(OFF)}$	- 3.6	0.8	V	

**Table 5. Electrical Specifications (DC)**

Unless otherwise noted, all typical values are at  $T_A = 25^\circ\text{C}$ ,  $V_{CC} - V_{EE} = 30\text{ V}$ ,  $V_{EE} = \text{Ground}$ ; all minimum and maximum specifications are at recommended operating conditions ( $T_A = -40$  to  $105^\circ\text{C}$ ,  $I_{F(\text{ON})} = 12$  to  $16\text{ mA}$ ,  $V_{F(\text{OFF})} = -3.6$  to  $0.8\text{ V}$ ,  $V_{EE} = \text{Ground}$ ,  $V_{CC} = 15$  to  $30\text{ V}$ ).

Parameter	Symbol	Min.	Typ.	Max.	Units	Test Conditions	Fig.	Note
High Level Peak Output Current	$I_{OH}$	0.5	1.5		A	$V_O = V_{CC} - 4\text{ V}$	2, 3, 16	5
		2.0			A	$V_O = V_{CC} - 15\text{ V}$		2
Low Level Peak Output Current	$I_{OL}$	0.5	2.0		A	$V_O = V_{EE} + 2.5\text{ V}$	5, 6, 17	5
		2.0			A	$V_O = V_{EE} + 15\text{ V}$		2
High Level Output Voltage	$V_{OH}$	$V_{CC} - 4$	$V_{CC} - 3$		V	$I_O = -100\text{ mA}$	1, 3, 18	6, 7
Low Level Output Voltage	$V_{OL}$		0.1	0.5	V	$I_O = 100\text{ mA}$	4, 6, 19	
High Level Supply Current	$I_{CCH}$		2.5	5.0	mA	Output Open, $I_F = 12\text{ mA}$	7, 8	
Low Level Supply Current	$I_{CCL}$		2.5	5.0	mA	Output Open, $V_F = -3.6$ to $0.8\text{ V}$		
Threshold Input Current Low to High	$I_{FLH}$	0.5	3.2	10.0	mA	$I_O = 0\text{ mA}$ , $V_O > 5\text{ V}$	9, 15, 20	
Threshold Input Voltage High to Low	$V_{FHL}$	0.8			V			
Input Forward Voltage	$V_F$	1.2	1.6	1.95	V	$I_F = 12\text{ mA}$		
Temperature Coefficient of Input Forward Voltage	$\Delta V_F / \Delta T_A$		-1.3		mV/ $^\circ\text{C}$	$I_F = 12\text{ mA}$		
Input Reverse Breakdown Voltage	$BV_R$	3			V	$I_R = 100\ \mu\text{A}$		
Input Capacitance	$C_{IN}$		70		pF	$f = 1\text{ MHz}$ , $V_F = 0\text{ V}$		
UVLO Threshold	$V_{UVLO+}$	11.0	12.3	13.5	V	$V_O > 5\text{ V}$ , $I_F = 12\text{ mA}$	21	
	$V_{UVLO-}$	9.5	10.7	12.0				
UVLO Hysteresis	$UVLO_{HYS}$		1.6		V			

**Table 6. Switching Specifications (AC)**

Unless otherwise noted, all typical values are at  $T_A = 25^\circ\text{C}$ ,  $V_{CC} - V_{EE} = 30\text{ V}$ ,  $V_{EE} = \text{Ground}$ ; all minimum and maximum specifications are at recommended operating conditions ( $T_A = -40$  to  $105^\circ\text{C}$ ,  $I_{F(\text{ON})} = 12$  to  $16\text{ mA}$ ,  $V_{F(\text{OFF})} = -3.6$  to  $0.8\text{ V}$ ,  $V_{EE} = \text{Ground}$ ,  $V_{CC} = 15$  to  $30\text{ V}$ ).

Parameter	Symbol	Min.	Typ.	Max.	Units	Test Conditions	Fig.	Note
Propagation Delay Time to High Output Level	$t_{PLH}$	0.10	0.30	0.50	$\mu\text{s}$	$R_g = 10\ \Omega$ , $C_g = 10\text{ nF}$ , $f = 10\text{ kHz}$ , Duty Cycle = 50%, $I_F = 12\text{ mA}$ to $16\text{ mA}$ , $V_{CC} = 15\text{ V}$ to $30\text{ V}$	10, 11, 12, 13, 14, 22	
Propagation Delay Time to Low Output Level	$t_{PHL}$	0.10	0.25	0.50	$\mu\text{s}$			
Pulse Width Distortion	PWD			0.30	$\mu\text{s}$			8
Propagation Delay Difference Between Any Two Parts	PDD ( $t_{PHL} - t_{PLH}$ )	-0.35		0.35	$\mu\text{s}$			9
Rise Time	$t_R$		0.10		$\mu\text{s}$		22	
Fall Time	$t_F$		0.10		$\mu\text{s}$			
UVLO Turn On Delay	$t_{UVLO\text{ ON}}$		0.80		$\mu\text{s}$	$V_O > 5\text{ V}$ , $I_F = 12\text{ mA}$	21	
UVLO Turn Off Delay	$t_{UVLO\text{ OFF}}$		0.60		$\mu\text{s}$	$V_O < 5\text{ V}$ , $I_F = 12\text{ mA}$		
Output High Level Common Mode Transient Immunity	$ CM_H $	40	50		kV/ $\mu\text{s}$	$T_A = 25^\circ\text{C}$ , $I_F = 12\text{ mA}$ , $V_{CM} = 1500\text{ V}$ , $V_{CC} = 30\text{ V}$	23	10, 11
Output Low Level Common Mode Transient Immunity	$ CM_L $	40	50		kV/ $\mu\text{s}$	$T_A = 25^\circ\text{C}$ , $V_F = 0\text{ V}$ , $V_{CM} = 1500\text{ V}$ , $V_{CC} = 30\text{ V}$		10, 12

**Table 7. Package Characteristics**

Unless otherwise noted, all typical values are at  $T_A = 25^\circ\text{C}$ ; all Minimum/Maximum specifications are at recommended operating conditions.

Parameter	Symbol	Min.	Typ.	Max.	Units	Test Conditions	Fig.	Note
Input-Output Momentary Withstand Voltage*	$V_{ISO}$	7500			$V_{RMS}$	RH < 50%, $t = 1 \text{ min.}, T_A = 25^\circ\text{C}$		13, 14
Input-Output Resistance	$R_{I-O}$		$10^{12}$		$\Omega$	$V_{I-O} = 500 \text{ VDC}$		14
Input-Output Capacitance	$C_{I-O}$		0.4		pF	$f = 1 \text{ MHz}$		
LED-to-Ambient Thermal Resistance	$R_{11}$		118.5		$^\circ\text{C/W}$	Thermal Model in Application Notes Below		15
LED-to-Detector Thermal Resistance	$R_{12}$		11.6					
Detector-to-LED Thermal Resistance	$R_{21}$		14					
Detector-to-Ambient Thermal Resistance	$R_{22}$		55.5					

\* The Input-Output Momentary Withstand Voltage is a dielectric voltage rating that should not be interpreted as an input-output continuous voltage rating. For the continuous voltage rating, refer to your equipment level safety specification or Avago Technologies Application Note 1074 entitled "Optocoupler Input-Output Endurance Voltage."

Notes:

- Derate linearly above  $70^\circ\text{C}$  free-air temperature at a rate of  $0.3 \text{ mA}/^\circ\text{C}$ .
- Maximum pulse width =  $10 \mu\text{s}$ . This value is intended to allow for component tolerances for designs with  $I_O$  peak minimum =  $2.0 \text{ A}$ . See applications section for additional details on limiting  $I_{OH}$  peak.
- Derate linearly above  $85^\circ\text{C}$  free-air temperature at a rate of  $-18.7 \text{ mW}/^\circ\text{C}$  (TBD)
- Derate linearly above  $85^\circ\text{C}$  free-air temperature at a rate of  $-14.1 \text{ mW}/^\circ\text{C}$  (TBD). The maximum LED junction temperature should not exceed  $125^\circ\text{C}$ .
- Maximum pulse width =  $50 \mu\text{s}$ .
- In this test  $V_{OH}$  is measured with a dc load current. When driving capacitive loads,  $V_{OH}$  will approach  $V_{CC}$  as  $I_{OH}$  approaches zero amps.
- Maximum pulse width =  $1 \text{ ms}$ .
- Pulse Width Distortion (PWD) is defined as  $|t_{PHL} - t_{PLH}|$  for any given device.
- The difference between  $t_{PHL}$  and  $t_{PLH}$  between any two ACNV3130 parts under the same test condition.
- Pin 1, 4 and 5 need to be connected to LED common.
- Common mode transient immunity in the high state is the maximum tolerable  $dV_{CM}/dt$  of the common mode pulse,  $V_{CM}$ , to assure that the output will remain in the high state (i.e.,  $V_O > 15.0 \text{ V}$ ).
- Common mode transient immunity in a low state is the maximum tolerable  $dV_{CM}/dt$  of the common mode pulse,  $V_{CM}$ , to assure that the output will remain in a low state (i.e.,  $V_O < 1.0 \text{ V}$ ).
- In accordance with UL1577, each optocoupler is proof tested by applying an insulation test voltage  $\geq 9000 \text{ Vrms}$  for 1 second (leakage detection current limit,  $I_{I-O} \mu\text{A}$ ).
- Device considered a two-terminal device: pins 1, 2, 3, 4 and 5 shorted together and pins 6, 7, 8, 9 and 10 shorted together.
- The device was mounted on a high conductivity test board as per JEDEC 51-7.



Figure 1.  $V_{OH}$  vs. temperature



Figure 2.  $I_{OH}$  vs. temperature



Figure 3.  $V_{OH}$  vs.  $I_{OH}$



Figure 4.  $V_{OL}$  vs. temperature

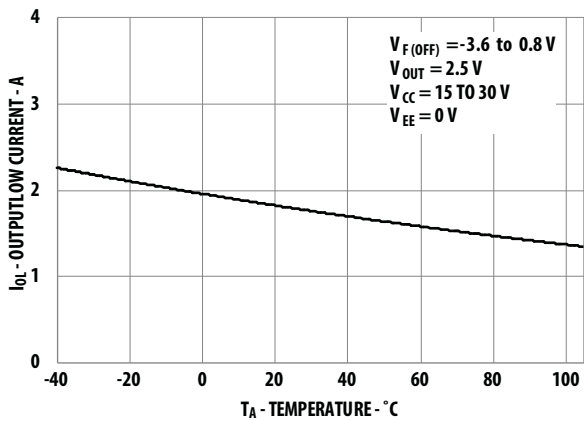

Figure 5.  $I_{OL}$  vs. temperature

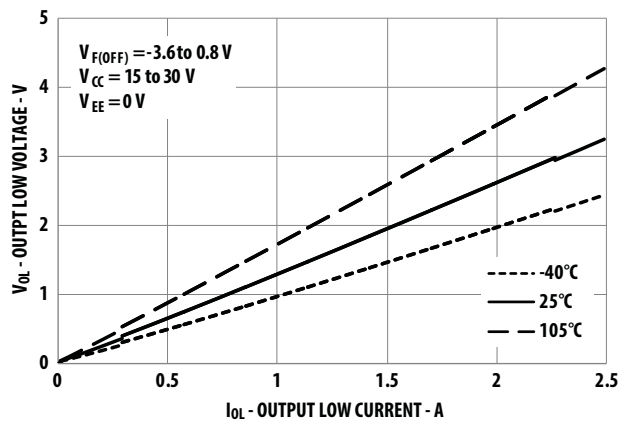

Figure 6.  $V_{OL}$  vs.  $I_{OL}$





Figure 7.  $I_{CC}$  vs. temperature



Figure 8.  $I_{CC}$  vs.  $V_{CC}$



Figure 9.  $I_{FLH}$  vs. temperature



Figure 10. Propagation delay vs.  $V_{CC}$



Figure 11. Propagation delay vs.  $I_F$



Figure 12. Propagation delay vs. temperature

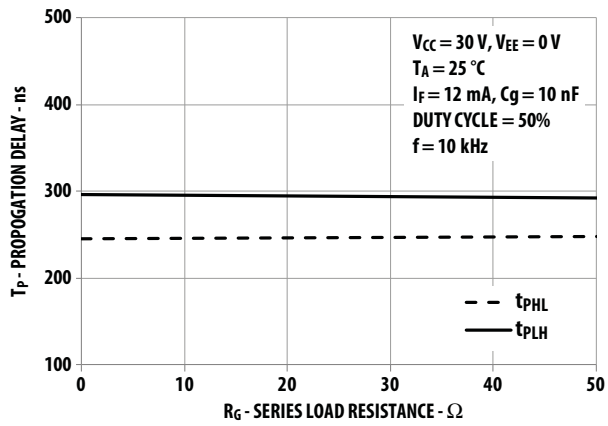

Figure 13. Propagation delay vs.  $R_g$

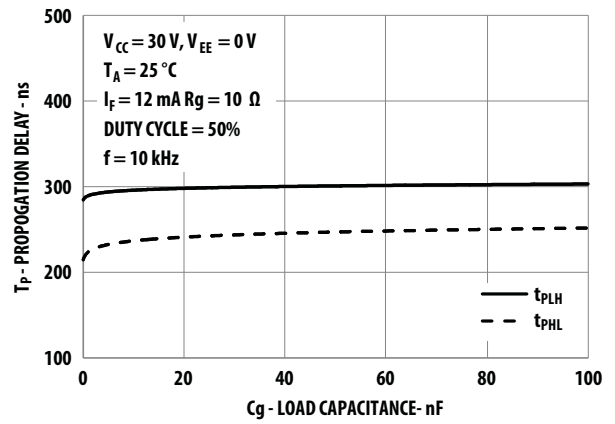

Figure 14. Propagation delay vs.  $C_g$

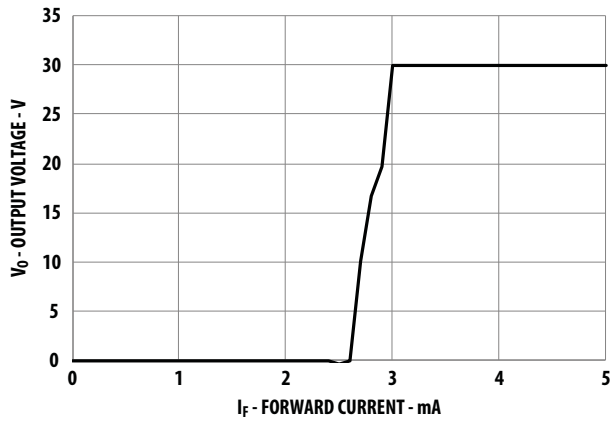

Figure 15. Transfer Characteristics



Figure 16.  $I_{OH}$  test circuit



Figure 17.  $I_{OL}$  test circuit

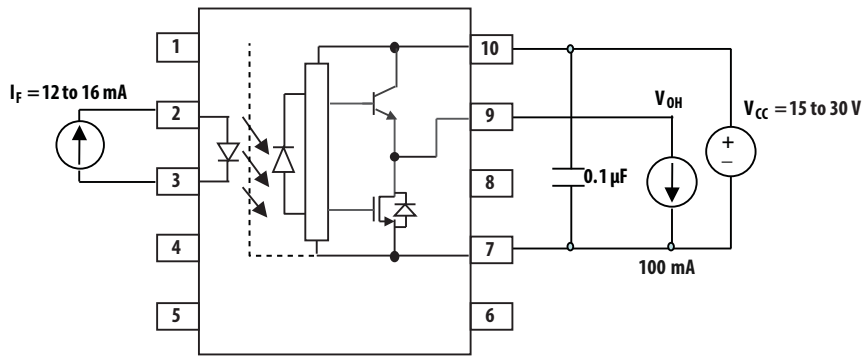

Figure 18.  $V_{OH}$  test circuit



Figure 19.  $V_{OL}$  test circuit

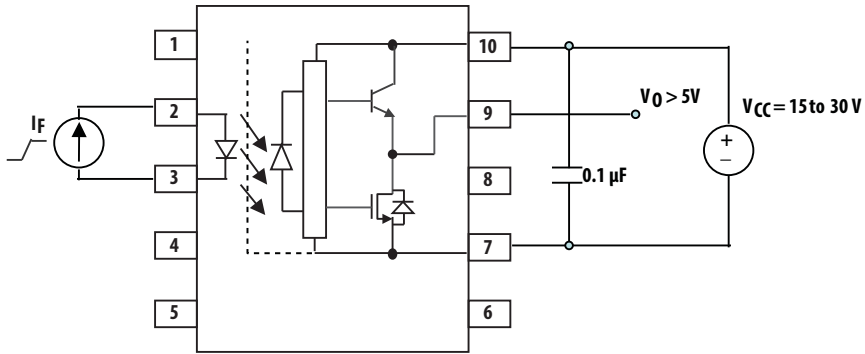

Figure 20.  $I_{FLH}$  test circuit

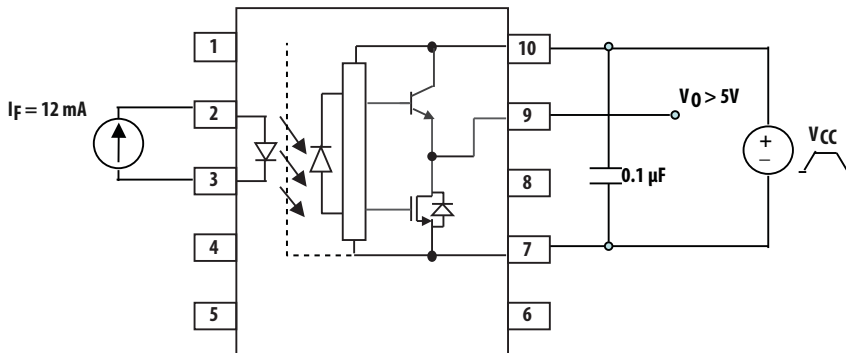

Figure 21. UVL0 test circuit



Figure 22.  $t_{PLH}$ ,  $t_{PHL}$ ,  $t_r$  and  $t_f$  test circuit and waveforms



Figure 23. CMR test circuit and waveforms

## Thermal Model

Definitions:

R<sub>11</sub>: Junction to Ambient Thermal Resistance of LED due to heating of LED

R<sub>12</sub>: Junction to Ambient Thermal Resistance of LED due to heating of Detector (Output IC)

R<sub>21</sub>: Junction to Ambient Thermal Resistance of Detector (Output IC) due to heating of LED.

R<sub>22</sub>: Junction to Ambient Thermal Resistance of Detector (Output IC) due to heating of Detector (Output IC).

P<sub>1</sub>: Power dissipation of LED (W).

P<sub>2</sub>: Power dissipation of Detector / Output IC (W).

T<sub>1</sub>: Junction temperature of LED (°C).

T<sub>2</sub>: Junction temperature of Detector (°C).

T<sub>A</sub>: Ambient temperature.

Ambient Temperature: Junction to Ambient Thermal Resistances were measured approximately 1.25 cm above optocoupler at ~23 °C in still air

Thermal Resistance	°C/W
R <sub>11</sub>	118.5
R <sub>12</sub>	11.6
R <sub>21</sub>	14
R <sub>22</sub>	55.5

This thermal model assumes the device is soldered onto a high conductivity board as per JEDEC 51-7. The temperature at the LED and Detector junctions of the optocoupler can be calculated using the equations below.

$$T_1 = (R_{11} * P_1 + R_{12} * P_2) + T_A \quad -- (1)$$

$$T_2 = (R_{21} * P_1 + R_{22} * P_2) + T_A \quad -- (2)$$

Using the given thermal resistances and thermal model formula in this datasheet, we can calculate the junction temperature for both LED and the output detector. Both junction temperatures should be within the absolute maximum rating of 125°C.

## Related Documents

### Application Note 1043

Common-Mode Noise: Sources and Solutions  
<http://www.avagotech.com/docs/AV02-3698EN>

### Application Note 1043

Common-Mode Noise: Sources and Solutions  
<http://www.avagotech.com/docs/AV02-3698EN>

### ESD Reliability Data

Plastics Optocouplers Product ESD and Moisture Sensitivity  
<http://www.avagotech.com/docs/AV02-0310EN>

For product information and a complete list of distributors, please go to our web site: [www.avagotech.com](http://www.avagotech.com)

Avago, Avago Technologies, and the A logo are trademarks of Avago Technologies in the United States and other countries. Data subject to change. Copyright © 2005-2012 Avago Technologies. All rights reserved.  
AV02-3789EN - October 12, 2012

**AVAGO**  
TECHNOLOGIES



## Стандарт Электрон Связь

Мы молодая и активно развивающаяся компания в области поставок электронных компонентов. Мы поставляем электронные компоненты отечественного и импортного производства напрямую от производителей и с крупнейших складов мира.

Благодаря сотрудничеству с мировыми поставщиками мы осуществляем комплексные и плановые поставки широчайшего спектра электронных компонентов.

Собственная эффективная логистика и склад в обеспечивает надежную поставку продукции в точно указанные сроки по всей России.

Мы осуществляем техническую поддержку нашим клиентам и предпродажную проверку качества продукции. На все поставляемые продукты мы предоставляем гарантию .

Осуществляем поставки продукции под контролем ВП МО РФ на предприятия военно-промышленного комплекса России , а также работаем в рамках 275 ФЗ с открытием отдельных счетов в уполномоченном банке. Система менеджмента качества компании соответствует требованиям ГОСТ ISO 9001.

Минимальные сроки поставки, гибкие цены, неограниченный ассортимент и индивидуальный подход к клиентам являются основой для выстраивания долгосрочного и эффективного сотрудничества с предприятиями радиоэлектронной промышленности, предприятиями ВПК и научно-исследовательскими институтами России.

С нами вы становитесь еще успешнее!

### Наши контакты:

**Телефон:** +7 812 627 14 35

**Электронная почта:** [sales@st-electron.ru](mailto:sales@st-electron.ru)

**Адрес:** 198099, Санкт-Петербург,  
Промышленная ул, дом № 19, литера Н,  
помещение 100-Н Офис 331