

Bluetooth 5 Module BM832/A/E Data Sheets

Ver 1.02 March 2019

BluNor BM832/A/E are powerful, highly flexible, ultra low power Bluetooth Low Energy (BLE) modules using Nordic nRF52 SoC. With an ARM Cortex™ M4(F) MCU, up to 512KB flash, 64KB RAM, embedded 2.4GHz multi-protocol transceiver, and an integrated PCB trace antenna. It allows faster time to market with reduced development cost.

BM832/A/E are designed to minimize PCB cost and to maximize efficiency in production line dedicated for Bluetooth module. The cost of using BM832/A/E modules can be lower than designing-in SoC at any quantity. At low cost, BM832/A/E offer full features. Inductors for DCDC converter are integrated. All 32 GPIOs are accessible.

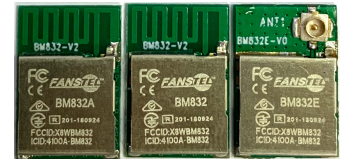

Bluetooth ranges are measured in environments with Low Multiple Path Interference (LMPI or antennas at 3 meters above ground) and antennas at 5 feet (1.52 meters, typical height of thermostat in the USA). Bluetooth range is much shorter in environments with radio frequency interference and severe multiple path interference.

BM832 Specifications:

- Nordic nRF52 with ARM Cortex M4F.
- Complete RF solution with integrated antenna
- Integrated DC-DC converter
- Serial Wire Debug (SWD)
- Nordic SoftDevice Ready
- Over-the-Air (OTA) firmware update
- Flash/RAM: 512KB/64KB or 256KB/32KB.
- 32 General purpose I/O pins
- 12 bit/200KSPS ADC, 8 configurable channels with programmable gain.
- 3X SPI Master/Slave (8Mbps)
- 3X 4-channel pulse width modulator (PWM)
- Low power comparator
- 2X 2-wire Master/Slave (I²C compatible)
- I2S audio interface
- UART (with CTS/RTS and DMA)
- 20 channel CPU independent Programmable Peripheral Interconnect (PPI).
- Quadrature Demodulator (QDEC)
- 128-bit AES HW encryption
- 5 x 32 bits, 3 x 24 bits Real Time Counters (RTC)
- Available NFC-A tag interface for OOB pairing
- Receiver Sensitivity: -96 dBm at 1Mbps
- TX power: +/- 0 dBm; programmable 4 dBm to -20dBm in 4 dB steps.
- Hybrid pins: 16 castellated and 24 LGA.
- Integrated PCB trace antenna;
- Operation voltage: 1.7V to 3.6V
- Embedded inductors for DCDC converter
- Operation temperature: -40°C to +85°C
- FCC ID: X8WBM832
- IC ID: 4100A-BM832
- CE: Certified
- TELEC: 201-180924
- Australia/New Zealand: Certified
- QDID:97989

Applications

- Wearable
- Beacons/Proximity
- Fitness/Sports
- Smart toys
- Connected appliances
- Lighting products
- Sensors
- Home and building automation
- Key fobs
- Wireless charger
- Interactive entertainment devices

Model Summaries

module	BM832	BM832A	BM832E
Flash/RAM	512KB/64KB	192KB/24KB	512KB/64KB
Size	10.2x15x1.9mm	10.2x15x1.9mm	10.2x15x1.9mm
GPIO		32	32
Antenna	PCB Trace	PCB Trace	u.FL
BT range, antenna at LMPI	340 meters	340 meters	
BT range, antenna at 1.52 M	270 meters	270 meters	
Availability	Production	Production	Production

Table Of Contents

1. Introduction.....	3
BM832 Block Diagram.....	3
BM832.....	3
BM832A.....	3
BM832E.....	3
2. Codes Development Using Nordic Tools.....	4
Easy, fast and safe code development.....	4
Over-The-Air DFU.....	4
SoftDevices.....	4
Development Tools.....	4
3. Product Overview.....	5
Nordic SoCs.....	5
Mechanical Drawings.....	7
BM832/BM832A Pin Functions.....	8
Mounting BM832 on the Host PCB.....	11
4. Bluetooth Range Measurements.....	12
Measurement Results.....	12
5. Evaluation Board.....	13
Nordic Development Environment.....	13
Loading Firmware into Evaluation Board Through a Nordic DK.....	13
Evaluation Board Schematic.....	17
Suggestion for Battery Power Application.....	18
6. Preloaded Firmware.....	19
Reprogram with New AT Command Codes.....	19
Reprogram with User's Codes.....	19
7. Miscellaneous.....	20
Soldering Temperature-Time Profile for Re-Flow Soldering.....	20
Cautions, Design Notes, and Installation Notes.....	20
Packaging.....	23
FCC Label.....	23
8. Revision History.....	24
9. Contact Us.....	25

1. Introduction

BluNor BM832 is powerful, highly flexible, ultra low power Bluetooth Low Energy (BLE) modules using Nordic nRF52 SoCs. With an ARM Cortex™ M4F MCU, available 512KB flash, 64KB RAM, embedded 2.4GHz multi-protocol transceiver, and an integrated antenna, it allows faster time to market with reduced development cost.

The following is a block diagram of BM832. Antenna circuit and main clock are integrated. All 32 GPIOs of nRF52832 can be accessed from main board. For lower power consumption at idle state, a 32.768 kHz crystal is added on the host board. Connection to an external NFC (Near Field Communication) antenna is provided.

BlurNor BM832A and BM832E are sister modules of BM832. They are pin to pin compatible.

In this data sheets, BM832, BM832E, and BM832A can be referred as B832.

BM832 Block Diagram

BM832 Series modules have the same features except the followings.

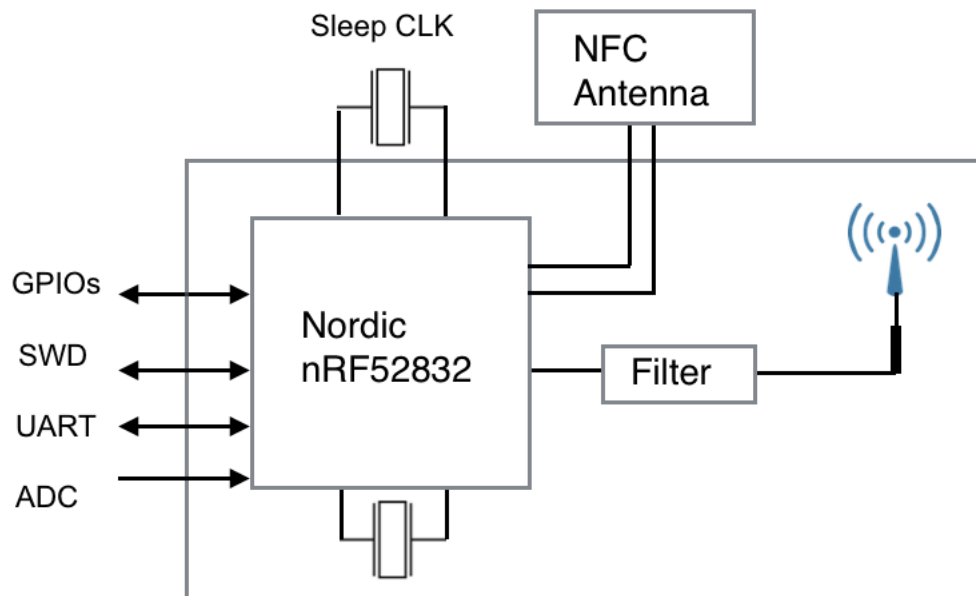

BM832

- 512KB flash, 64 KB RAM
- Integrated PCB trace antenna



BM832A

- 192 KB flash, 24 KB RAM
- Integrated PCB trace antenna



BM832E

- 512KB flash/64KB RAM
- An u.FL connector for external antenna
- Certified with ANT020 external antenna.



Bluetooth 5 Module BM832/A/E Data Sheets

2. Codes Development Using Nordic Tools

Development tools by Nordic and other third party development tools recommended by Nordic should be used .

Easy, fast and safe code development

Nordic development environment for nRF52 offers a clean separation between application code development and embedded protocol stacks. This means compile, link and run time dependencies with the embedded stack and associated debugging challenges are removed. The Bluetooth low energy and ANT stack is a pre-compiled binary, leaving application code to be compiled stand-alone. The embedded stack interface uses an asynchronous and event driven model removing the need for RTOS frameworks.

Over-The-Air DFU

The nRF52 SoC is supported by an Over-The-Air Device Firmware Upgrade (OTA DFU) feature. This allows for in the field updates of application software and SoftDevice.

SoftDevices

The Nordic protocol stacks are known as SoftDevices and complement the nRF52 Series SoCs. All nRF52 Series are programmable with software stacks from Nordic. This bring maximum flexibility to application development and allows the latest stack version to be programmed into the SoC.

SoftDevices available from Nordic:

- **S112 SoftDevice**

The S112 SoftDevice is a *Bluetooth* low energy peripheral protocol stack solution. It supports up to four peripheral connections with an additional broadcaster role running concurrently. The S112 SoftDevice integrates a *Bluetooth* low energy Controller and Host, and provides a full and flexible API for building *Bluetooth* low energy nRF52 System on Chip (SoC) solutions. S112 can be used for for BM832A.

- **S132 SoftDevice**

The S132 SoftDevice is a *Bluetooth* low energy Central and Peripheral protocol stack solution. It supports up to twenty connections with an additional observer and a broadcaster role all running concurrently. The S132 SoftDevice integrates a *Bluetooth* low energy Controller and Host, and provides a full and flexible API for building *Bluetooth* low energy nRF52 System on Chip (SoC) solutions. S132 can be used for BM832 or BM832A.

Development Tools

Nordic Semiconductor provides a complete range of hardware and software development tools for the nRF52 Series devices. nRF52 DK board is recommended for firmware development.

3. Product Overview

Nordic SoCs

For full description of the SoC, please download data sheets from Nordic Semiconductor website.

<https://www.nordicsemi.com/eng/Products/Bluetooth-low-energy>

The following is a block diagram of Nordic nRF52832 Bluetooth Low Energy (BLE) SoC. NFC is not supported in nRF52810.

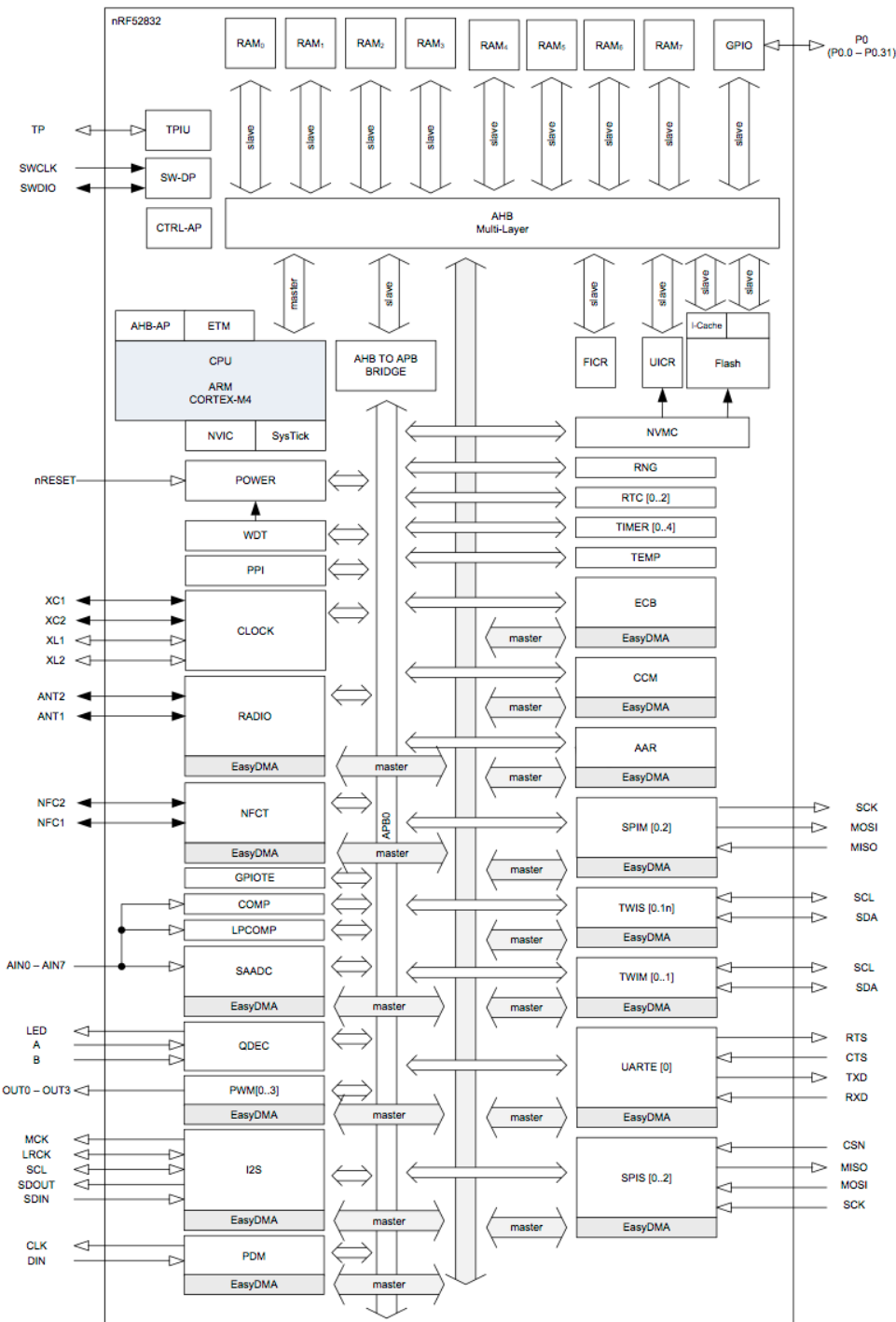

The 32 bit ARM Cortex M4F MCU with hardware supports for DSP instructions and floating point operations, code density and execution speed are higher than other Cortex M MCU. The Programmable Peripheral Interconnect (PPI) system provides a 20-channel bus for direct and autonomous system peripheral communication without CPU intervention. This brings predictable latency times for peripheral to peripheral interaction and power saving benefits associated with leaving CPU idle. The device has 2 global power modes ON/OFF, but all system blocks and peripherals have individual power management control which allows for an automatic switching RUN/IDLE for system blocks based only on those required/not required to achieve particular tasks.

The radio supports Bluetooth low energy and ANT. Output power is scalable from a maximum of +4dBm down to -20 dBm in 4dB steps. Sensitivity is increased to -96 dBm to -89 dBm, depending on data rate. Sensitivity for BLE is -96 dBm, and -92.5 dBm for ANT.

The NFC block supports NFC-A tags with proximity detection and Wake-on-field from low power mode. The NFC enables Out-Of-Band (OOB) Bluetooth pairing of devices and thus greatly simplifying deployment.

Mechanical Drawings

The followings are mechanical drawings of BTM832 and BM832A, top view. Size of module is 10.2x15.0x1.9mm. X-axis and Y-axis coordinate of each pin is shown in table.

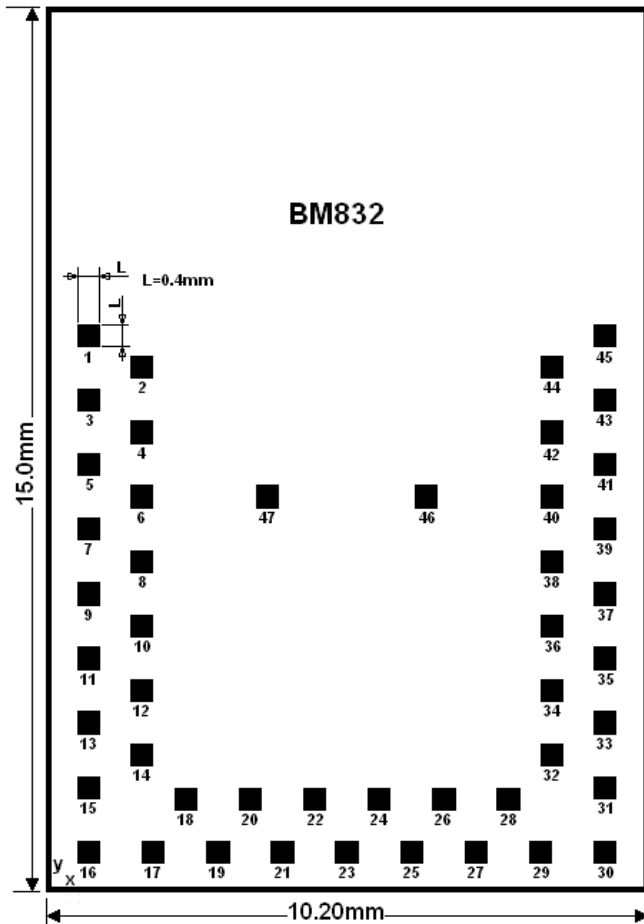

	X (mm)	Y (mm)		X (mm)	Y (mm)		X (mm)	Y (mm)
16	0.69	0.65	30	9.49	0.65	17	1.79	0.65
15	0.69	1.75	31	9.49	1.75	19	2.89	0.65
13	0.69	2.85	33	9.49	2.85	21	3.99	0.65
11	0.69	3.95	35	9.49	3.95	23	5.09	0.65
9	0.69	5.05	37	9.49	5.05	25	6.19	0.65
7	0.69	6.15	39	9.49	6.15	27	7.29	0.65
5	0.69	7.25	41	9.49	7.25	29	8.39	0.65
3	0.69	8.35	43	9.49	8.35			
1	0.69	9.45	45	9.49	9.45	18	2.34	1.55
						20	3.44	1.55
14	1.59	2.3	32	8.59	2.3	22	4.54	1.55
12	1.59	3.4	34	8.59	3.4	24	5.64	1.55
10	1.59	4.5	36	8.59	4.5	26	6.74	1.55
8	1.59	5.6	38	8.59	5.6	28	7.84	1.55
6	1.59	6.7	40	8.59	6.7			
4	1.59	7.8	42	8.59	7.8	46	6.44	6.7
2	1.59	8.9	44	8.59	8.9	47	3.74	6.7

Library components for PADS and EAGLE can be downloaded from

<http://www.fanstel.com/download-document/>

For other PCB layout tools, please download evaluation Gerber files and extract library component.

BM832/BM832A Pin Functions

The followings are BM832/BM832A pin assignment. Pin functions are in a table below. Please refer to Nordic nRF52832 and nRF52810 Product Specifications for detailed descriptions and features supported.

http://infocenter.nordicsemi.com/pdf/nRF52832_PS_v1.4.pdf

BM832A uses nRF52810, Product Specifications:

http://infocenter.nordicsemi.com/pdf/nRF52810_PS_v1.2.pdf

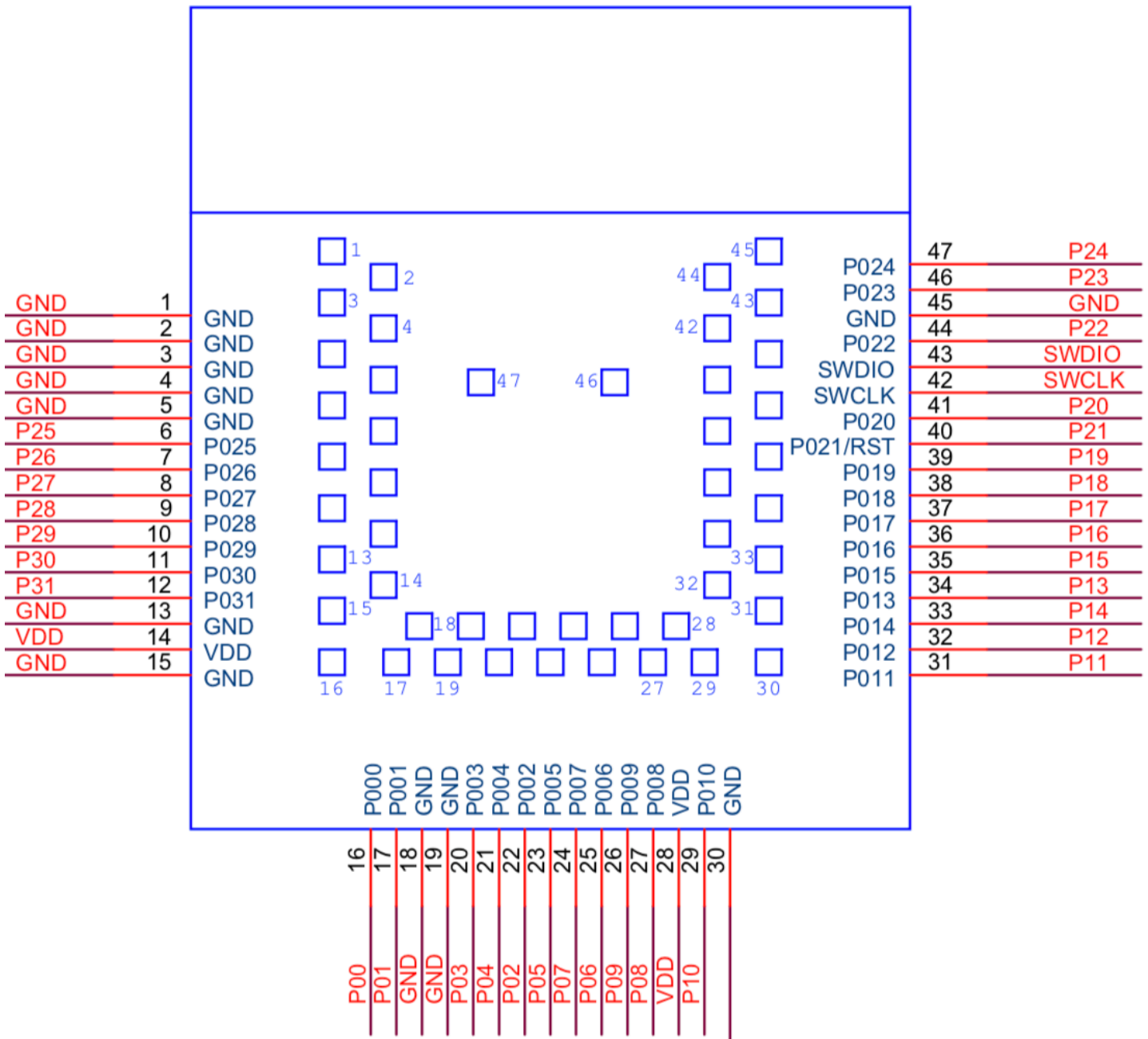

Bluetooth 5 Module BM832/A/E Data Sheets

Ver 1.02 March 2019

BM832/BM832A Pin Functions

BM832		nRF52832/nRF52810		
pin#	pin name	pin#	pin name	Descriptions
1	GND	45	VSS	Ground
2	GND			Ground
3	GND			Ground
4	GND			Ground
5	GND			Ground
6	P025	37	P0.25	GPIO
7	P026	38	P0.26	GPIO
8	P027	39	P0.27	GPIO
9	P028	40	P0.28/AIN4	GPIO, Analog input
10	P029	41	P0.29/AIN5	GPIO, Analog input
11	P030	42	P0.30/AIN6	GPIO, Analog input
12	P031	43	P0.31/AIN7	GPIO, Analog input
13	GND			Ground
14	VDD	36	VDD	DC supply 1.7V to 3.6V
15	GND			Ground
16	P000	2	P0.00/XL1	GPIO, connection for 32.768kHz crystal
17	P001	3	P0.01/XL2	GPIO, connection for 32.768kHz crystal
18	GND			Ground
19	GND			Ground
20	P003	5	P0.03/AIN1	GPIO, Analog input
21	P004	6	P0.04/AIN2	GPIO, Analog input
22	P002	4	P0.02/AIN0	GPIO, Analog input
23	P005	7	P0.05/AIN3	GPIO, Analog input
24	P007	9	P0.07	GPIO
25	P006	8	P0.06	GPIO
26	P009	11	P0.09/NFC1	GPIO, NFC antenna connection (nRF52832 only)
27	P008	10	P0.08	GPIO
28	VDD		VDD	DC supply 1.7V to 3.6V
29	P010	12	P0.10/NFC2	GPIO, NFC antenna connection (nRF52832 only)
30	GND			Ground
31	P011	14	P0.11	GPIO, used as UART RX on evaluation board
32	P012	15	P0.12	GPIO, used as UART TX on evaluation board
33	P014	17	P0.14	GPIO
34	P013	16	P0.13	GPIO
35	P015	18	P0.15	GPIO
36	P016	19	P0.16	GPIO
37	P017	20	P0.17	GPIO
38	P018	21	P0.18	GPIO
39	P019	22	P0.19	GPIO
40	P021/RST	24	P0.21/RST	GPIO, configurable as RESET pin
41	P020	23	P0.20	GPIO
42	SWDCLK	25	SWDCLK	Serial Wire Debug clock input

Bluetooth 5 Module BM832/A/E Data Sheets

Ver 1.02 March 2019

43	SWDIO	26	SWDIO	Serial Wire Debug I/O
44	P022	27	P0.22	GPIO
45	GND			Ground
46	P023	28	P0.23	GPIO
47	P024	29	P0.24	GPIO

Mounting BM832 on the Host PCB

The following figure shows recommended mounting of BM832 module on the host PCB.

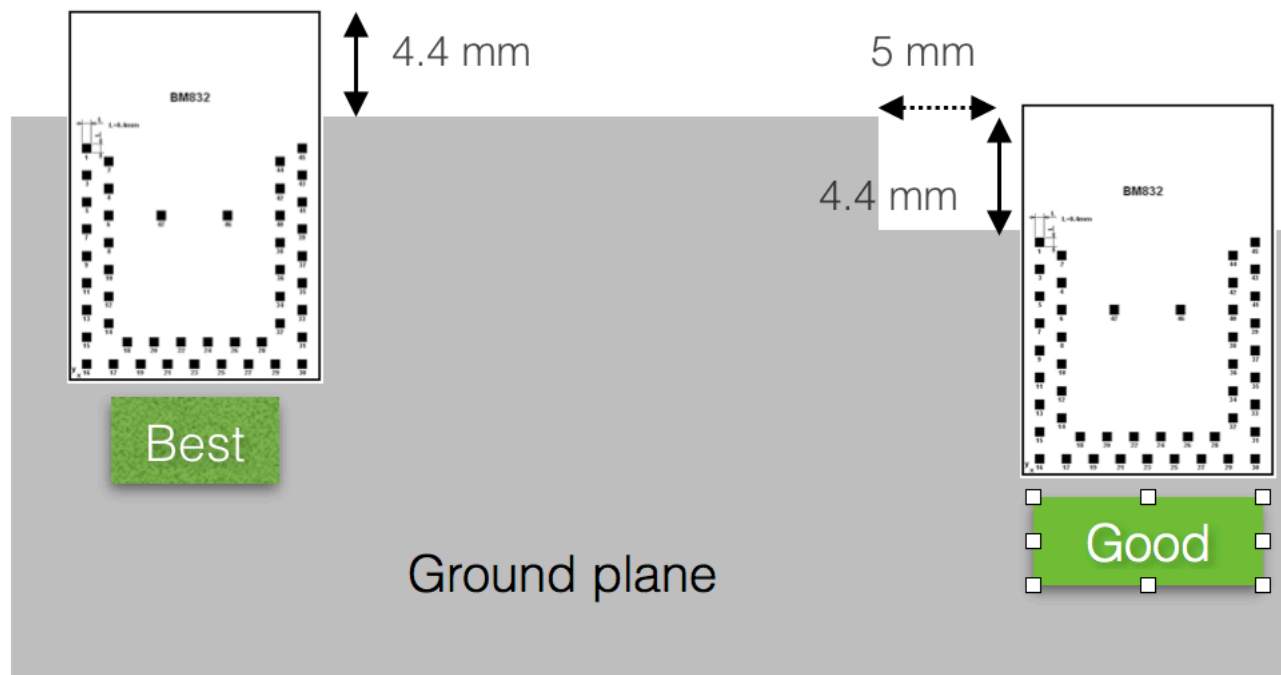

- For the best Bluetooth range performance, the antenna area of module shall extend 4.4 mm outside the edge of host PCB board, or 4.4 mm outside the edge of a ground plane.
- The next choice is to place a module on a corner of host PCB, the antenna area shall extend 4.4 mm from the edge of ground plane. Ground plane shall be at least 5 mm from the edge of the antenna area of module.
- We don't recommend mounting BM832 module in the middle of a host PCB.

For the best Bluetooth range performance, keep all external metal at least 30mm from the antenna area.

4. Bluetooth Range Measurements

Bluetooth range measurement hex codes can be downloaded from **Bluetooth Range Measurements** section of this webpage.

<http://www.fanstel.com/download-document/>

Description of measurement site, measurement methods, and range raw data are available at:

<https://www.fanstel.com/testreport/>

Measurement Results

Bluetooth ranges are measured for antennas at two heights.

- 1.52 meters or 5 feet, the typical height of thermostat in the USA.
- 3.0 meters. It has 85% Fresnel zone clearance when transmitter and receiver are 400 meters away. Multiple path interference caused by ground is low.

Antenna height, meters	3.0	1.52
BM832, BT832A Bluetooth range, meters	340	270

In actual application environments, Bluetooth range is much shorter because of radio frequency interference and severe multiple path interference.

Bluetooth 5 Module BM832/A/E Data Sheets

5. Evaluation Board

An evaluation board can be used to evaluate performance of module and to develop and test your firmware before an application-specific host board is developed.

Nordic Development Environment

Nordic Semiconductor provides a complete range of hardware and software development tools for the nRF52 Series devices. nRF52 DK board is recommended for firmware development. Document and Software development tools can be downloaded by the following links.

Get started with Nordic chip and all online documents.

http://infocenter.nordicsemi.com/index.jsp?topic=/com.nordic.infocenter.nrf52/dita/nrf52/development/nrf52_dev_kit.html&cp=1_1

Nordic SDK with many example projects.

https://developer.nordicsemi.com/nRF5_SDK/

Nordic development zone.

<https://devzone.nordicsemi.com/tutorials/b/getting-started/posts/development-with-gcc-and-eclipse>

Programming the Nordic chip

Download and install Nrf5x-Command-Line Tools

<https://www.nordicsemi.com/eng/nordic/Products/nRF52840/nRF5x-Command-Line-Tools-Win32/58850>

Download and install nRFgo Studio

<https://www.nordicsemi.com/eng/Products/2.4GHz-RF/nRFgo-Studio/>

nRF52DK

The nRF52 DK is a versatile single board development kit for *Bluetooth*® low energy, ANT and 2.4GHz proprietary applications using the nRF52832 SoC. This kit supports development for the nRF52832 and nRF52810 SoC.

It supports the standard Nordic Software Development Tool-chain using SES, Keil, IAR and GCC. Program/Debug options on the kit is Segger J-Link OB.

Loading Firmware into Evaluation Board Through a Nordic DK

Procedures to connect a Nordic DK to a Fanstel nRF52 module evaluation board.

- Connect Nordic nRF52DK debug out to Fanstel evaluation board debug in using the 10-pin flat cable as shown below.
- Connect Nordic nRF52DK to PC.
- Connect a DC power source to micro or mini USB port of evaluation board.

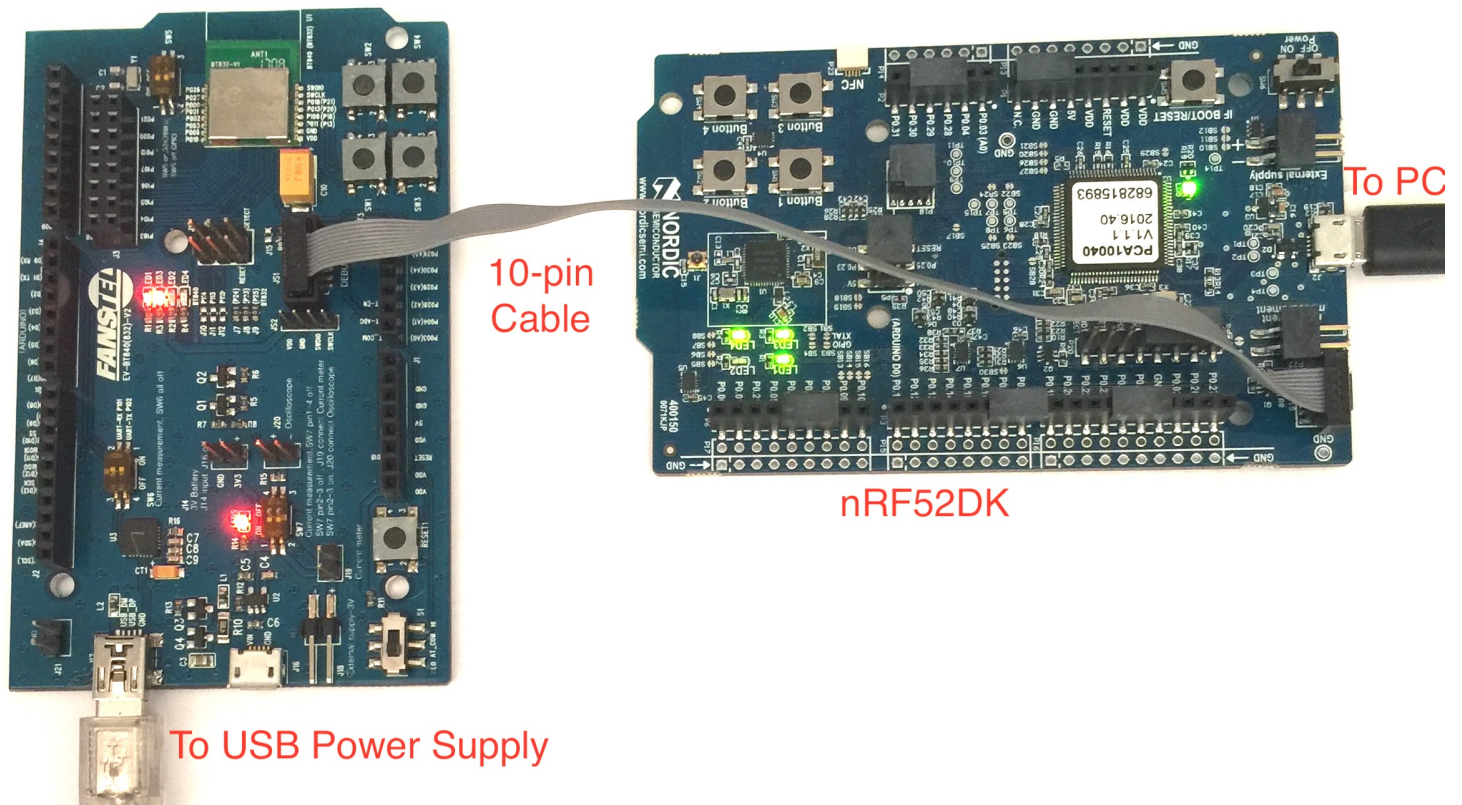

Check COM Port Connection

After connecting nRF52DK and an nRF52 sensor/evaluation board, you can see You can J-Link device and COM port on the PC control panel Device Manager.

Starting Nordic nRFgo

Open nRFgo Studio.

1. Click **Segger 682990549** as in the example below.
2. Erase all if needed
3. Browse for Bootloader and program. After programming bootloader, you can use OTA for firmware update.
4. Browse for the SoftDevice and program.
5. Browse for the application hex file and program

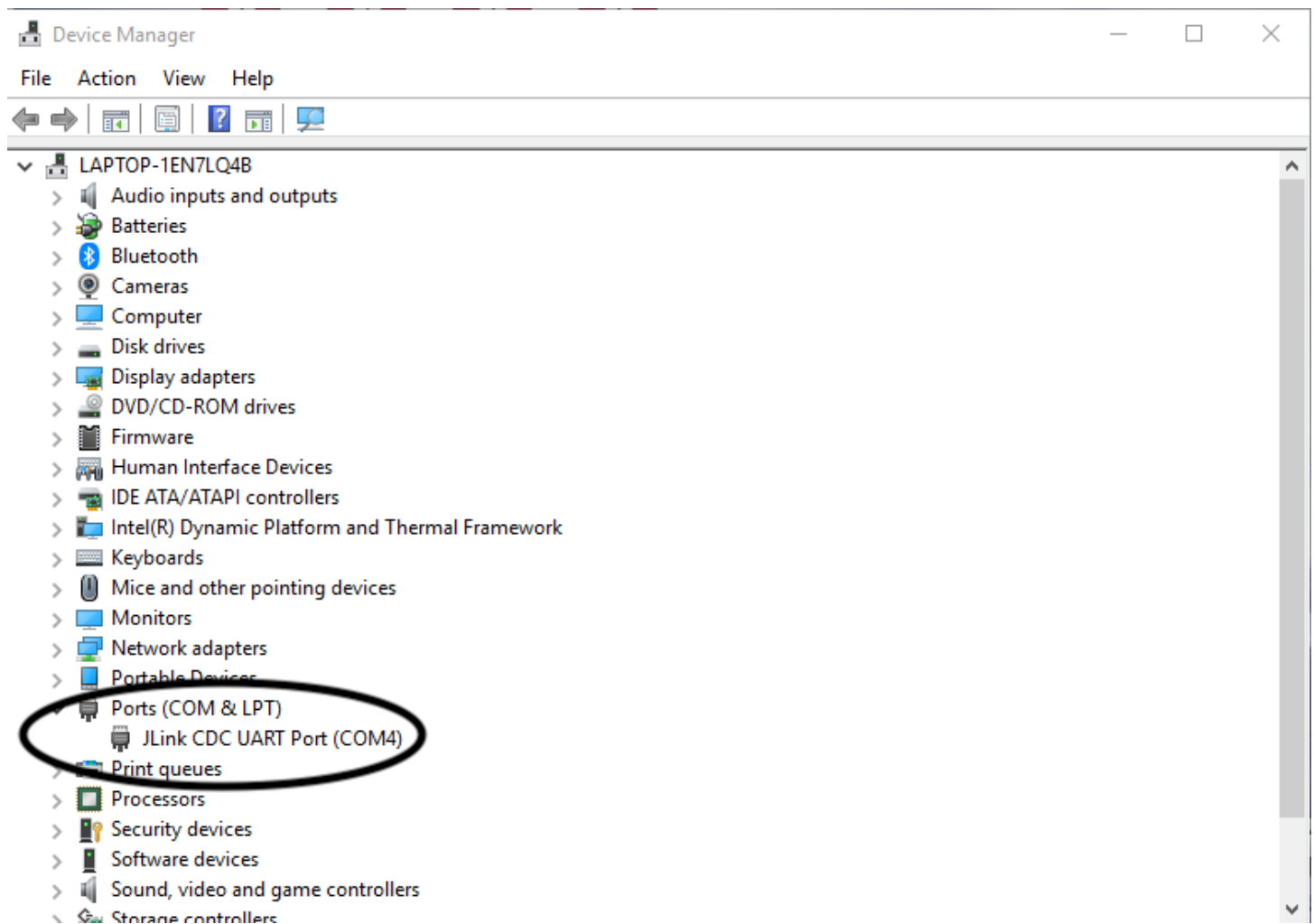

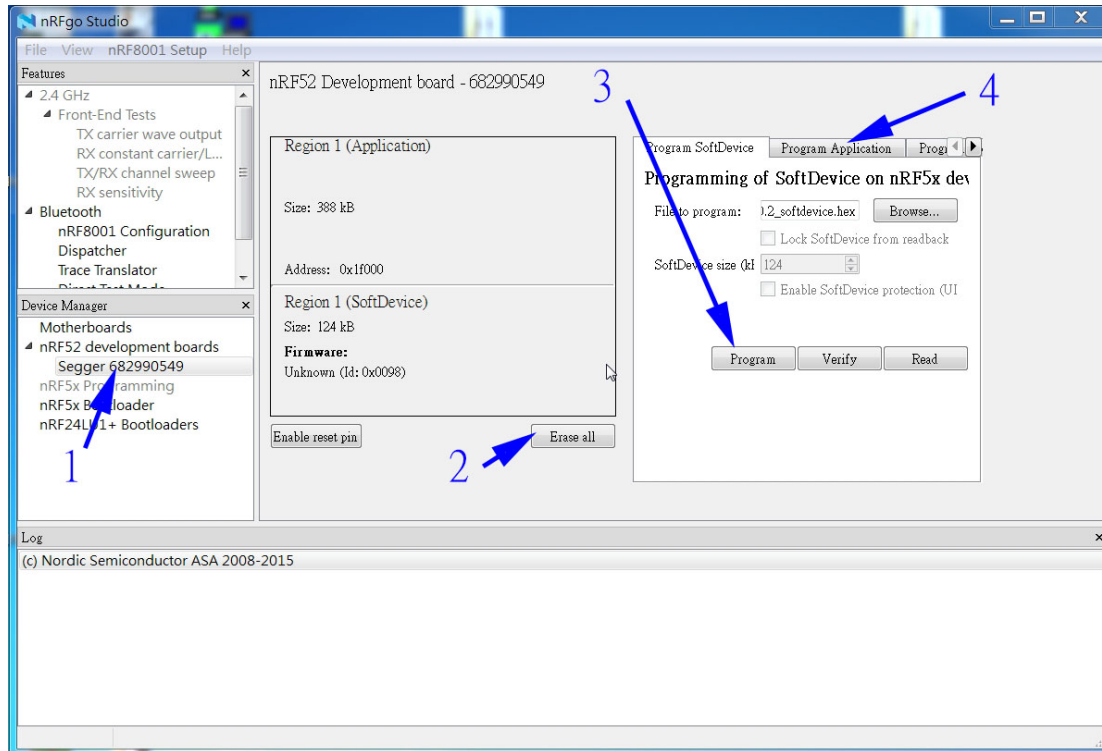

Evaluation Board Schematic

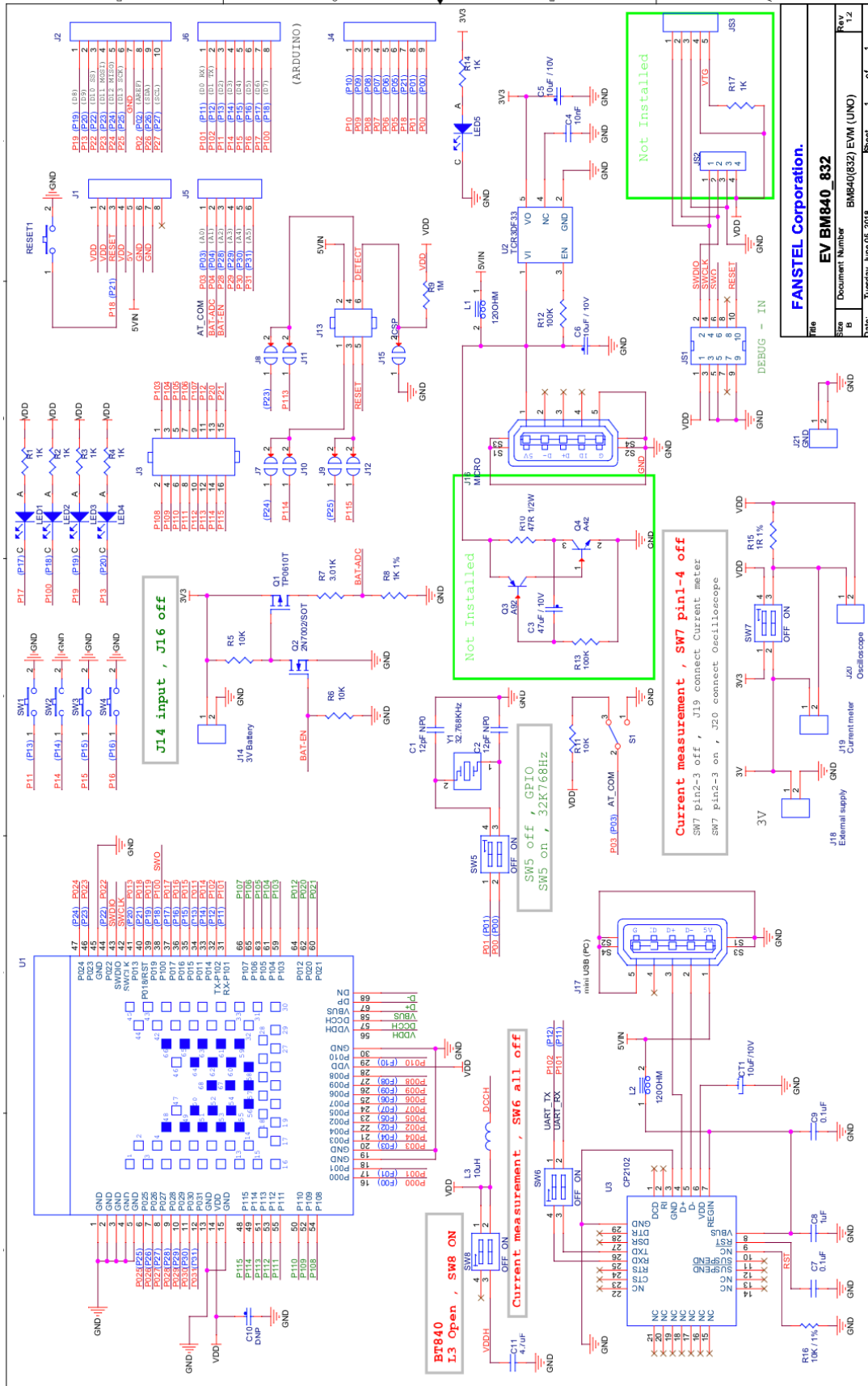

Bluetooth 5 Module BM832/A/E Data Sheets

Suggestion for Battery Power Application

Standby current consumption is important for battery-powered product. We suggest adding a 32.768 kHz crystal and 2 capacitors as shown in the upper left corner of the evaluation board schematics. The 32MHz main clock won't be active at idle state to save power.

Two inductors required for DCDC converter are inside BM832 module. You can enable DCDC to lower power consumption.

Bluetooth 5 Module BM832/A/E Data Sheets

6. Preloaded Firmware

Modules are loaded with production test codes to

- enable Bluetooth transmitter for power measurement.
- set each GPIO pin to high/low for continuity measurement.

Production test codes are not erased when modules are shipped from factory. To reprogram with your codes, follow the procedures in **Reprogram with User's Codes** Section.

Starting with November 2018 production (date code 1847 or later), AT command codes for UART interface with boot loader are used in production testing. You can use AT command codes as loaded or erase and reprogram with your codes.

Fanstel may upgrade AT command codes and use new firmware in production testing. If you prefer to use a specific version of AT command codes, please download and save.

AT command codes are free to use as loaded. Programming services for a specific version of codes or user's codes are available in factory for fee and with Minimum Order Quantity.

Reprogram with New AT Command Codes

Up to date AT command codes for UART and SPI interfaces can be downloaded from Fanstel website.

<http://www.fanstel.com/download-document/>

You can reprogram new AT command codes using OTA DFU (Over The Air Device Firmware Upgrade).

Reprogram with User's Codes

To load your application codes, SoftDevice, and bootloader, you need to **chiperase** and reprogram modules. An example for BT832 module:

```
//program BT832 Bootloader+Softdevice+Application hex
```

```
nrfjprog -f NRF52 --program BT832_AT_3in1PC181113.hex --chiperase --reset
```

```
//The file BT832_AT_3in1PC181113.hex = softdevice S1320v6.1.1+BT832_AT_UARTwithout32K+bootloader
```

7. Miscellaneous

Soldering Temperature-Time Profile for Re-Flow Soldering

Maximum number of cycles for re-flow is 2. No opposite side re-flow is allowed due to module weight.

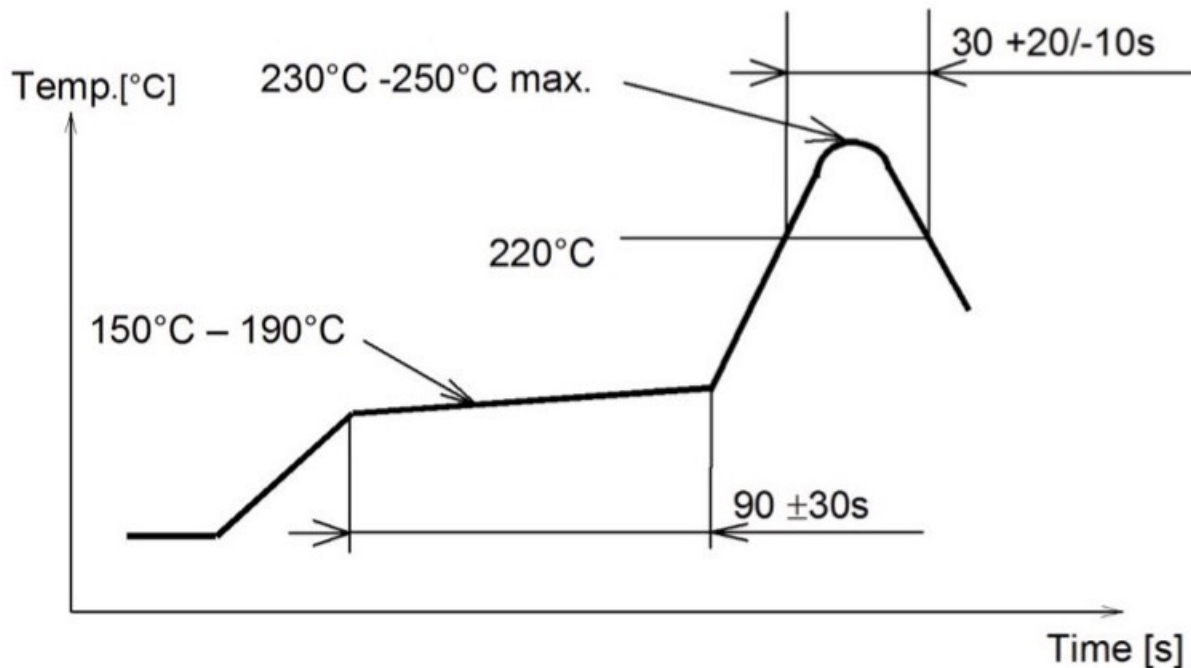

Cautions, Design Notes, and Installation Notes

Failure to follow the guidelines set forth in this document may result in degrading of the product's functions and damage to the product.

Design Notes

- (1) Follow the conditions written in this specification, especially the control signals of this module.
- (2) The supply voltage has to be free of AC ripple voltage (for example from a battery or a low noise regulator output). For noisy supply voltages, provide a decoupling circuit (for example a ferrite in series connection and a bypass capacitor to ground of at least 47uF directly at the module).
- (3) This product should not be mechanically stressed when installed.
- (4) Keep this product away from heat. Heat is the major cause of decreasing the life of these products.
- (5) Avoid assembly and use of the target equipment in conditions where the products' temperature may exceed the maximum tolerance.
- (6) The supply voltage should not be exceedingly high or reversed. It should not carry noise and/or spikes.
- (7) this product away from other high frequency circuits.

Bluetooth 5 Module BM832/A/E Data Sheets

Notes on Antenna and PCB Layout

- (1) Don't use a module with internal antenna inside a metal case.
- (2) For PCB layout:
 - Avoid running any signal line below module whenever possible,
 - No ground plane below antenna,
 - If possible, cut-off the portion of main board PCB below antenna.

Installation Notes

- (1) Reflow soldering is possible twice based on the time-temperature profile in this data sheets. Set up the temperature at the soldering portion of this product according to this reflow profile.
- (2) Carefully position the products so that their heat will not burn into printed circuit boards or affect the other components that are susceptible to heat.
- (3) Carefully locate these products so that their temperatures will not increase due to the effects of heat generated by neighboring components.
- (4) If a vinyl-covered wire comes into contact with the products, then the cover will melt and generate toxic gas, damaging the insulation. Never allow contact between the cover and these products to occur.
- (5) This product should not be mechanically stressed or vibrated when reflowed.
- (6) If you want to repair your board by hand soldering, please keep the conditions of this chapter.
- (7) Do not wash this product.
- (8) Refer to the recommended pattern when designing a board.
- (9) Pressing on parts of the metal cover or fastening objects to the metal will cause damage to the unit.
- (10) For more details on LGA (Land Grid Array) soldering processes refer to the application note.

Usage Condition Notes

- (1) Take measures to protect the unit against static electricity. If pulses or other transient loads (a large load applied in a short time) are applied to the products, check and evaluate their operation before assembly on the final products.
- (2) Do not use dropped products.
- (3) Do not touch, damage or soil the pins.
- (4) Follow the recommended condition ratings about the power supply applied to this product.
- (5) Electrode peeling strength: Do not add pressure of more than 4.9N when soldered on PCB
- (6) Pressing on parts of the metal cover or fastening objects to the metal cover will cause damage.
- (7) These products are intended for general purpose and standard use in general electronic equipment, such as home appliances, office equipment, information and communication equipment.

Storage Notes

- (1) The module should not be stressed mechanically during storage.
- (2) Do not store these products in the following conditions or the performance characteristics of the product, such as RF performance will be adversely affected:

- Storage in salty air or in an environment with a high concentration of corrosive gas.
 - Storage in direct sunlight
 - Storage in an environment where the temperature may be outside the range specified.
 - Storage of the products for more than one year after the date of delivery storage period.
- (3) Keep this product away from water, poisonous gas and corrosive gas.
- (4) This product should not be stressed or shocked when transported.
- (5) Follow the specification when stacking packed crates (max. 10).

Safety Conditions

These specifications are intended to preserve the quality assurance of products and individual components. Before use, check and evaluate the operation when mounted on your products. Abide by these specifications, without deviation when using the products. These products may short-circuit. If electrical shocks, smoke, fire, and/or accidents involving human life are anticipated when a short circuit occurs, then provide the following failsafe functions, as a minimum.

- (1) Ensure the safety of the whole system by installing a protection circuit and a protection device.
- (2) Ensure the safety of the whole system by installing a redundant circuit or another system to prevent a dual fault causing an unsafe status.

Other Cautions

- (1) This specification sheet is copyrighted. Reproduction of this data sheets is permissible only if reproduction is without alteration and is accompanied by all associated warranties, conditions, limitations, and notices.
- (2) Do not use the products for other purposes than those listed.
- (3) Be sure to provide an appropriate failsafe function on your product to prevent an additional damage that may be caused by the abnormal function or the failure of the product.
- (4) This product has been manufactured without any ozone chemical controlled under the Montreal Protocol.
- (5) These products are not intended for other uses, other than under the special conditions shown below. Before using these products under such special conditions, check their performance and reliability under the said special conditions carefully to determine whether or not they can be used in such a manner.
- In liquid, such as water, salt water, oil, alkali, or organic solvent, or in places where liquid may splash.
 - In direct sunlight, outdoors, or in a dusty environment
 - In an environment where condensation occurs.
 - In an environment with a high concentration of harmful gas.
- (6) If an abnormal voltage is applied due to a problem occurring in other components or circuits, replace these products with new products because they may not be able to provide normal performance even if their electronic characteristics and appearances appear satisfactory.
- (7) When you have any question or uncertainty, contact Fanstel.

Bluetooth 5 Module BM832/A/E Data Sheets

Packaging

Production modules are delivered in reel, 1000 modules in each reel.

FCC LABEL

The Original Equipment Manufacturer (OEM) must ensure that the OEM modular transmitter must be labeled with its own FCC ID number. This includes a clearly visible label on the outside of the final product enclosure that displays the contents shown below. If the FCC ID is not visible when the equipment is installed inside another device, then the outside of the device into which the equipment is installed must also display a label referring to the enclosed equipment

The end product with this module may subject to perform FCC part 15 unintentional emission test requirement and be properly authorized.

This device is intended for OEM integrator only.

Bluetooth 5 Module BM832/A/E Data Sheets

8. Revision History

- June 2018, Ver. 0.50: The first draft copy
- August 2018, Ver. 0.60, The second draft copy
- September 2018, Ver. 1.00: Initial release.
- December 2018, Ver. 1.01: add certification information and add preloaded firmware section.
- March 2019, Ver. 1.02: update module photos with certification information

Bluetooth 5 Module BM832/A/E Data Sheets

9. Contact Us

United States:

Fanstel Corp.

7466 E. Monte Cristo Ave. Scottsdale AZ 85260

Tel. 1 480-948-4928

Fax. 1-480-948-5459

Email: info@fanstel.com

Website: www.fanstel.com

Taiwan:

Fanstel Corp.

10F-10, 79 Xintai Wu Road

Xizhu, New Taipei City, Taiwan 22101

泛世公司

臺灣省新北市汐止區新臺五路79號10樓之10, 22101

Tel. 886-2-2698-9328

Fax. 886-2-2698-4813

Email: info@fanstel.com

Website: www.fanstel.com

China:

Fanstel Technologies Corp.

11 Jiale Street

Ping-Dih, Long-Gang, Shen Zhen, GD 518117

泛世康科技(深圳)有限公司

廣東省深圳市龍崗區坪地鎮佳樂街11號

Tel. 86-755-8409-0928

Fax. 86-755-8409-0973

QQ. 3076221086

Email: info@fanstel.com

Website: www.fanstel.com



**Стандарт
Электрон
Связь**

Мы молодая и активно развивающаяся компания в области поставок электронных компонентов. Мы поставляем электронные компоненты отечественного и импортного производства напрямую от производителей и с крупнейших складов мира.

Благодаря сотрудничеству с мировыми поставщиками мы осуществляем комплексные и плановые поставки широчайшего спектра электронных компонентов.

Собственная эффективная логистика и склад в обеспечивает надежную поставку продукции в точно указанные сроки по всей России.

Мы осуществляем техническую поддержку нашим клиентам и предпродажную проверку качества продукции. На все поставляемые продукты мы предоставляем гарантию .

Осуществляем поставки продукции под контролем ВП МО РФ на предприятия военно-промышленного комплекса России , а также работаем в рамках 275 ФЗ с открытием отдельных счетов в уполномоченном банке. Система менеджмента качества компании соответствует требованиям ГОСТ ISO 9001.

Минимальные сроки поставки, гибкие цены, неограниченный ассортимент и индивидуальный подход к клиентам являются основой для выстраивания долгосрочного и эффективного сотрудничества с предприятиями радиоэлектронной промышленности, предприятиями ВПК и научно-исследовательскими институтами России.

С нами вы становитесь еще успешнее!

Наши контакты:

Телефон: +7 812 627 14 35

Электронная почта: sales@st-electron.ru

Адрес: 198099, Санкт-Петербург,
Промышленная ул, дом № 19, литера Н,
помещение 100-Н Офис 331