

LT3761EMSE High Voltage LED Controller with Internal PWM Dimming

DESCRIPTION

DC1772A is a high voltage LED controller with internal PWM dimming. It generates its own PWMOUT waveform for accurate PWM dimming with up to 25:1 brightness ratio. It accepts an input voltage from 8V to 60V (8V UVLO and 9.1V rising turn-on), and drives up to 60V of LEDs at 1A (when PVIN is less than V_{LED}). DC1772A features both PWM and analog dimming of the LED string. It has an $\overline{OPENLED}$ flag that indicates when the LED string has been removed.

DC1772A features high efficiency at 350kHz switching frequency. At high LED string voltages up to 60V and 1A of LED current, the single switch controller has 94% efficiency. The open LED overvoltage protection uses the IC's constant voltage regulation loop to regulate the output to approximately 69.8V if the LED string is opened although it may reach 74V peak during transient from running LEDs to open. The maximum LED string voltage can be raised from 60V to 65V (or higher) with a simple change of feedback resistors.

For low input voltage operation, the CTRL pin voltage is reduced as the input voltage drops below 10V, reducing LED brightness and restraining the peak switch currents in order to limit inductor and switch size. UVLO turns the LEDs off when PVIN drops below 8V.

DC1772A PWM dimming is simplified when compared with other LED drivers. The LT[®]3761 generates its own PWMOUT dimming waveform at a frequency determined

by the capacitance on the PWM pin (C8 gives 300Hz for DC1772A). The PWMOUT duty cycle is determined by the voltage on the DIM terminal. Between 0V and 7.7V VDIM gives between 4% and 96% PWM duty cycle. Information regarding PWM dimming ratios and performance can be found in the LT3761 data sheet in the Applications Information section. Analog dimming is also simple to use with a single voltage source on the CTRL terminal.

Modifications can be made to DC1772A in order to convert the board to higher or lower power or from an LED driver to a constant voltage regulator or battery charger. It can easily be changed from a boost topology to a SEPIC, buck mode, or buck-boost mode LED driver. Please consult the factory or the LT3761 data sheet for details. It can be modified to provide LED+ to GND short-circuit protection as well.

The LT3761 data sheet gives a complete description of the part, operation and applications information. The data sheet must be read in conjunction with this demo manual for demonstration circuit DC1772A. The LT3761EMSE is assembled in a 16-lead plastic MSOP MSE package with a thermally enhanced ground pad. Proper board layout is essential for maximum thermal performance. See the data sheet section Layout Considerations.

Design files for this circuit board are available at <http://www.linear.com/demo>

LT, LT, LTC, LTM, Linear Technology and the Linear logo are registered trademarks of Linear Technology Corporation. All other trademarks are the property of their respective owners.

DEMO MANUAL DC1772A

PERFORMANCE SUMMARY

Specifications are at $T_A = 25^\circ\text{C}$

PARAMETER	CONDITION	VALUE (TYPICAL)
Input Voltage PVIN Range	Operating	8V to V_{LED} (Up to 60V)
Switching Frequency	$R6 = 29.4k$	350kHz
I_{LED}	$RS2 = 0.25\Omega$ $10V < PVIN < V_{LED}$ (60V)	1A
Low PVIN I_{LED} (CTRL Foldback)	$RS2 = 0.25\Omega$ $PVIN = 8.5V$ $RS2 = 0.25\Omega$ $PVIN = 9V$	930mA 975mA
V_{LED} Range	$R3 = 1M$ $R4 = 18.2k$	$PVIN < V_{LED} < 60V$
Open LED Voltage	$R3 = 1M$ $R4 = 18.2k$	69.8V
Typical Efficiency	$PVIN = 14V$ $V_{LED} = 60V$ $I_{LED} = 1A$ $PWM = INTVCC$	94%
PVIN Under Voltage Lockout (Falling Turn-Off)	$R1 = 499k$ and $R2 = 90.9k$	8V
PVIN Under Voltage Lockout (Rising Turn-On)	$R1 = 499k$ and $R2 = 90.9k$	9.1V
INTVCC	Operating	7.85V
Peak Switch Current Limit	$RS1 = 0.008\Omega$	12.5A
PWMOUT Dimming Duty Cycle	$VDIM = 7.7V$ $VDIM = 4V$ $VDIM = 1.5V$ $VDIM = 0.4V$	96% 50% 10% 4.3%
Internal PWM Dimming Frequency	$C8 = 0.047\mu F$ $0V < VDIM < 7.7V$	300Hz

QUICK START PROCEDURE

Demonstration circuit 1772A is easy to set up to evaluate the performance of the LT3761EMSE. Follow the procedure below:

1. Connect a string of LEDs that will run with forward voltage less than 60V, but greater than PVIN, to the LED+ and LED- terminals on the PCB as shown in Figure 1.
2. Connect the EN/UVLO terminal to GND.
3. With power off, connect the input power supply to the PVIN and GND terminals. Make sure that the PVIN DC input voltage will not exceed 60V (or V_{LED}).
4. Connect the DIM terminal to a voltage between 0V and 7.7V to set the internal PWMOUT dimming duty cycle. If this terminal is left floating the converter will run with approximately 12% PWMOUT dimming duty cycle. Pull the PWM terminal high to INTVCC to set the converter at 100% duty cycle.
5. Turn the input power supply on and make sure the voltage is between 8V and 60V (or V_{LED}).
6. Release the EN/UVLO-to-GND connection.
7. Observe the LED string running at the programmed LED current and brightness related to the programmed PWMOUT duty cycle.
8. To change the brightness with PWM dimming, simply vary the VDIM voltage between 0V and 7.7V with the PWM terminal floating.
9. To change the brightness with analog dimming, simply attach a voltage source on the CTRL terminal and reduce the voltage below 1.2V.
10. Observe the reduction of brightness in the LED string when PWM or analog dimming.

QUICK START PROCEDURE

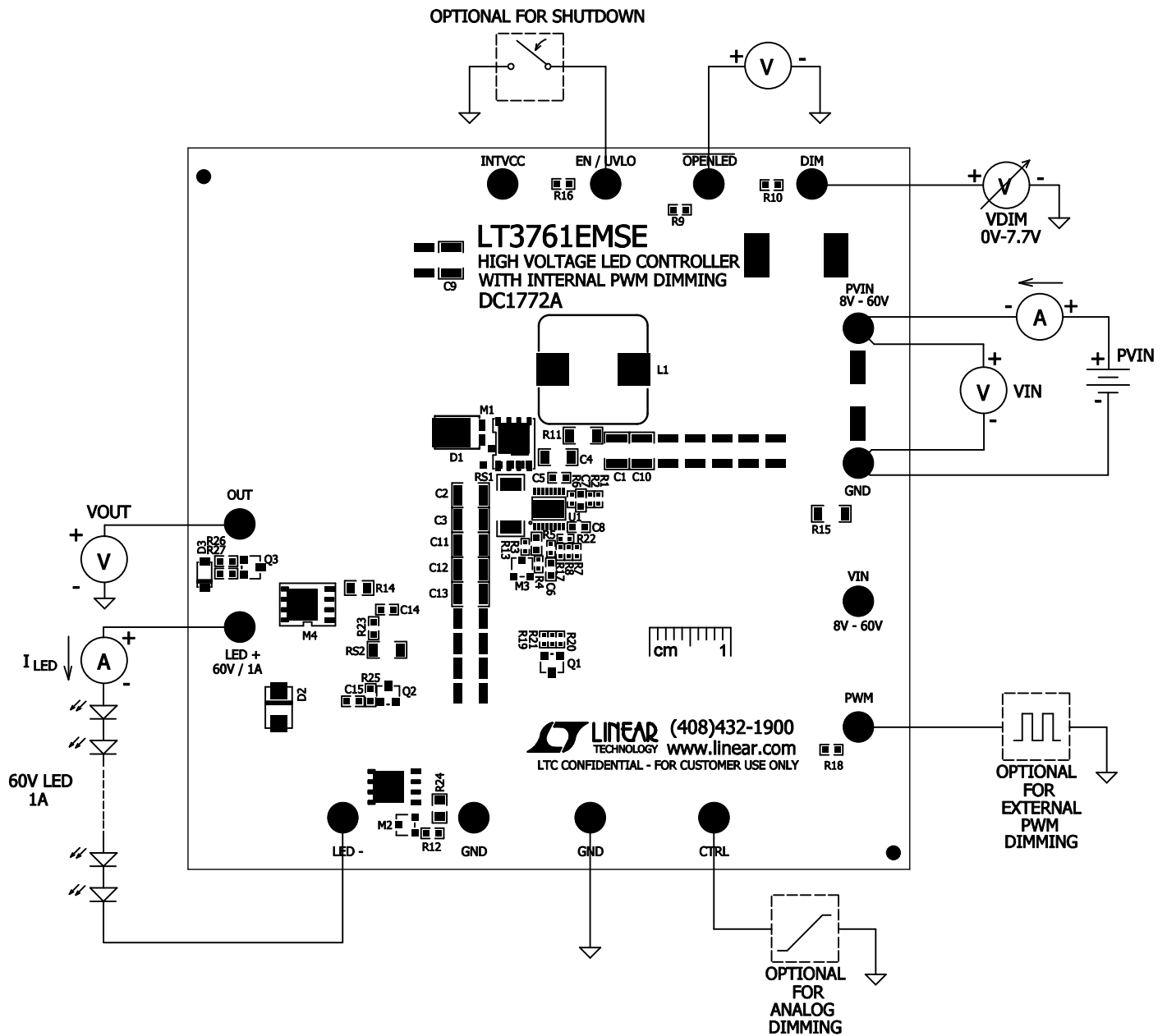

Figure 1. Test Procedure Setup Drawing for DC1772A

QUICK START PROCEDURE

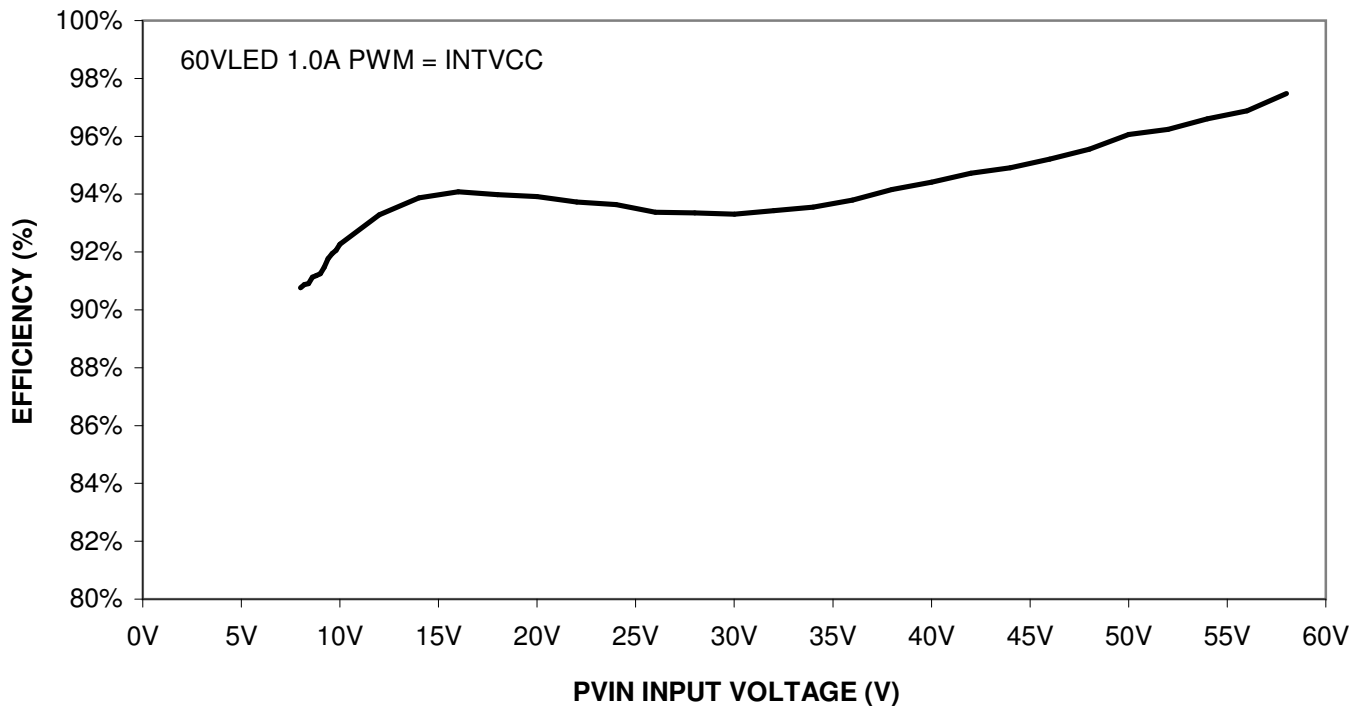

Figure 2. DC1772A Efficiency with 60V LEDs at 1A and 100% PWMOUT Duty Cycle

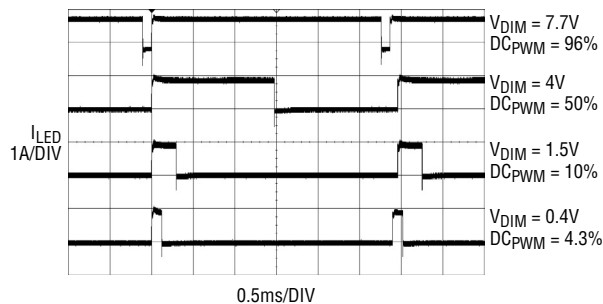

Figure 3. DC1772A 300Hz PWM Dimming Waveforms at Different PWMOUT Duty Cycles

QUICK START PROCEDURE

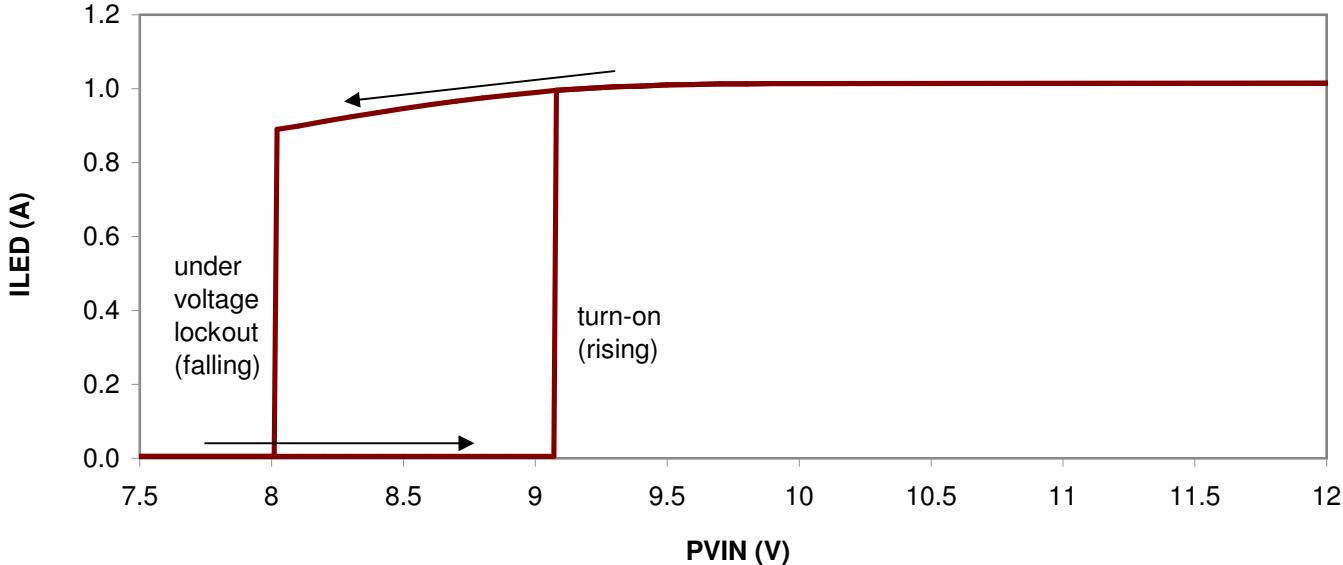

Figure 4. DC1772A CTRL LED Current Foldback at Low PVIN with UVLO Falling and Rising

DEMO MANUAL DC1772A

PARTS LIST

ITEM	QTY	REFERENCE	PART DESCRIPTION	MANUFACTURER/PART NUMBER
Required Circuit Components				
1	2	C1, C10	Cap., X7S 4.7 μ F 100V 10% 1210	TDK C3225X7S2A475K
2	4	C2, C3, C11, C12	Cap., X7R 2.2 μ F 100V 10% 1210	TDK C3225X7R2A225K
3	1	C4	Cap., X7R 1 μ F 100V 20% 1206	TDK C3216X7R2A105M
4	1	C5	Cap., X5R 1 μ F 10V 10% 0603	AVX, 0603ZD105KAT2A
5	1	C6	Cap., X7R 4700pF 25V 20% 0603	AVX, 06033C472MATAT2A
6	1	C7	Cap., X5R 0.01 μ F 16V 20% 0603	AVX, 0603YD103MAT2A
7	1	C8	Cap., X7R 0.047 μ F 50V 10% 0603	AVX, 06035C473KAT2A
8	1	D1	Schottky Diode 5A PowerDi5	Diodes Inc. PDS5100H
9	1	L1	Inductor, 10 μ H HC9-SERIES/COOPER	Cooper Bussmann, HC9-100-R
10	1	M1	MOSFET N-Chan., 100V	Infineon, BSC123N08NS3G
11	1	M2	MOSFET N-Chan., 100V	Siliconix Si2328DS-T1-GE3
12	1	RS1	Res., Chip., 0.008 Ω 1/2W 1% 2010	Vishay WSL20108L000FEA
13	1	RS2	Res., Chip., 0.25 Ω 1/2W 1% 1206	Vishay WSL1206R2500FEA
14	1	R1	Res., Chip, 499k 0.06W 1% 0402	Vishay CRCW0402499KFKED
15	1	R2	Res., Chip, 90.9k, 0.06W 1% 0402	Vishay CRCW040290K9FKED
16	1	R3	Res., Chip, 1M, 0.1W 1% 0603	Vishay CRCW06031M00FKED
17	1	R4	Res., Chip, 18.2k, 0.06W 1% 0402	Vishay CRCW040218K2FKED
18	1	R5	Res., Chip 10k, 0.06W 5% 0402	Vishay CRCW040210K0JKED
19	1	R6	Res., Chip, 29.4k, 0.06W 1% 0402	Vishay CRCW040229K4FKED
20	1	R7	Res., Chip 1M, 0.06W 5% 0402	Vishay CRCW04021M00JKED
21	1	R8	Res., Chip, 140k, 0.06W 1% 0402	Vishay CRCW0402140KFKED
22	1	R9	Res., Chip 100k, 0.1W 5% 0603	Vishay CRCW0603100KJKEA
23	1	R10	Res., Chip, 124k, 0.1W 1% 0603	Vishay CRCW0603124KFKED
24	1	U1	I.C., LED Driver MSOP(16)-MSE	Linear Tech. Corp. LT3761EMSE
Optional Electrical Components				
1	0	C9, C13(OPT)	Cap., 1210	
2	0	C14, C15 (OPT)	Cap., 0603	
3	0	D2 (OPT)	Rectifier, ESIC SMA	
4	0	D3 (OPT)	Diode, 1N4148W, SOD-123	
5	0	M3 (OPT)	MOSFET N-Chan., SOT23	(OPT)
6	0	M4 (OPT)	MOSFET P S08-PWR	(OPT)
7	0	Q1, Q2, Q3 (OPT)	PNP SOT23	(OPT)
8	1	R11	Res., Chip, 0 Ω , 1206	Vishay CRCW12060000Z0EA
9	1	R12	Res., Chip 0 Ω , 0603	Vishay CRCW06030000Z0ED
10	0	R13, R17, R19-22 (OPT)	Res., 0402	
11	0	R14, R24 (OPT)	Res., 0805	
12	0	R15 (OPT)	Res., 1206	
13	0	R16, R18, R23, R25-R27 (OPT)	Res., 0603	
Optional Hardware				
1	14	E1-E14	Turret, Testpoint	Mill Max 2501-2-00-80-00-00-07-0

SCHEMATIC DIAGRAM

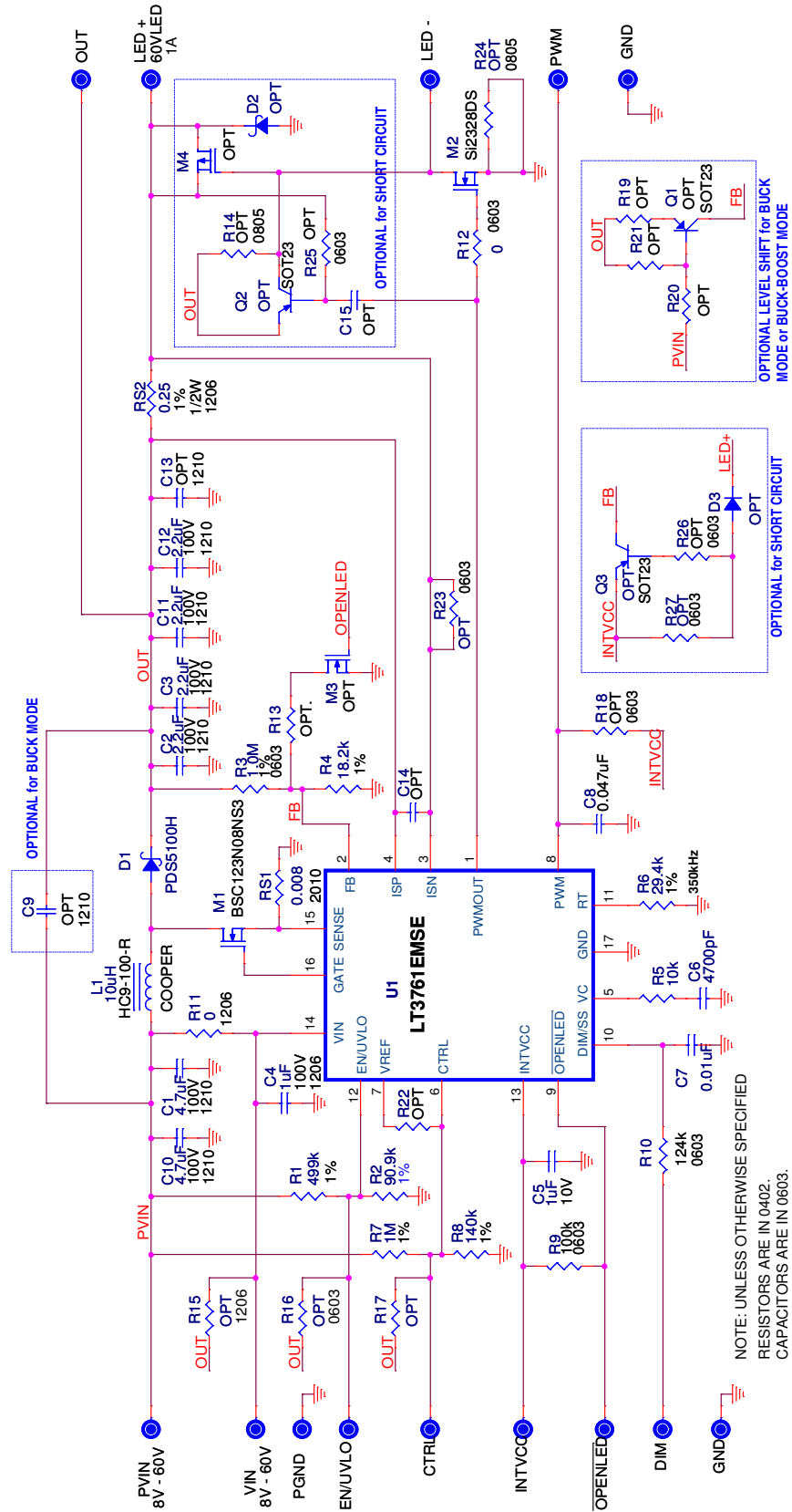

DEMO MANUAL DC1772A

DEMONSTRATION BOARD IMPORTANT NOTICE

Linear Technology Corporation (LTC) provides the enclosed product(s) under the following **AS IS** conditions:

This demonstration board (DEMO BOARD) kit being sold or provided by Linear Technology is intended for use for **ENGINEERING DEVELOPMENT OR EVALUATION PURPOSES ONLY** and is not provided by LTC for commercial use. As such, the DEMO BOARD herein may not be complete in terms of required design-, marketing-, and/or manufacturing-related protective considerations, including but not limited to product safety measures typically found in finished commercial goods. As a prototype, this product does not fall within the scope of the European Union directive on electromagnetic compatibility and therefore may or may not meet the technical requirements of the directive, or other regulations.

If this evaluation kit does not meet the specifications recited in the DEMO BOARD manual the kit may be returned within 30 days from the date of delivery for a full refund. **THE FOREGOING WARRANTY IS THE EXCLUSIVE WARRANTY MADE BY THE SELLER TO BUYER AND IS IN LIEU OF ALL OTHER WARRANTIES, EXPRESSED, IMPLIED, OR STATUTORY, INCLUDING ANY WARRANTY OF MERCHANTABILITY OR FITNESS FOR ANY PARTICULAR PURPOSE. EXCEPT TO THE EXTENT OF THIS INDEMNITY, NEITHER PARTY SHALL BE LIABLE TO THE OTHER FOR ANY INDIRECT, SPECIAL, INCIDENTAL, OR CONSEQUENTIAL DAMAGES.**

The user assumes all responsibility and liability for proper and safe handling of the goods. Further, the user releases LTC from all claims arising from the handling or use of the goods. Due to the open construction of the product, it is the user's responsibility to take any and all appropriate precautions with regard to electrostatic discharge. Also be aware that the products herein may not be regulatory compliant or agency certified (FCC, UL, CE, etc.).

No License is granted under any patent right or other intellectual property whatsoever. **LTC assumes no liability for applications assistance, customer product design, software performance, or infringement of patents or any other intellectual property rights of any kind.**

LTC currently services a variety of customers for products around the world, and therefore this transaction **is not exclusive**.

Please read the DEMO BOARD manual prior to handling the product. Persons handling this product must have electronics training and observe good laboratory practice standards. **Common sense is encouraged.**

This notice contains important safety information about temperatures and voltages. For further safety concerns, please contact a LTC application engineer.

Mailing Address:

Linear Technology
1630 McCarthy Blvd.
Milpitas, CA 95035

Copyright © 2004, Linear Technology Corporation



**Стандарт
Электрон
Связь**

Мы молодая и активно развивающаяся компания в области поставок электронных компонентов. Мы поставляем электронные компоненты отечественного и импортного производства напрямую от производителей и с крупнейших складов мира.

Благодаря сотрудничеству с мировыми поставщиками мы осуществляем комплексные и плановые поставки широчайшего спектра электронных компонентов.

Собственная эффективная логистика и склад в обеспечивает надежную поставку продукции в точно указанные сроки по всей России.

Мы осуществляем техническую поддержку нашим клиентам и предпродажную проверку качества продукции. На все поставляемые продукты мы предоставляем гарантию .

Осуществляем поставки продукции под контролем ВП МО РФ на предприятия военно-промышленного комплекса России , а также работаем в рамках 275 ФЗ с открытием отдельных счетов в уполномоченном банке. Система менеджмента качества компании соответствует требованиям ГОСТ ISO 9001.

Минимальные сроки поставки, гибкие цены, неограниченный ассортимент и индивидуальный подход к клиентам являются основой для выстраивания долгосрочного и эффективного сотрудничества с предприятиями радиоэлектронной промышленности, предприятиями ВПК и научно-исследовательскими институтами России.

С нами вы становитесь еще успешнее!

Наши контакты:

Телефон: +7 812 627 14 35

Электронная почта: sales@st-electron.ru

Адрес: 198099, Санкт-Петербург,
Промышленная ул, дом № 19, литера Н,
помещение 100-Н Офис 331