

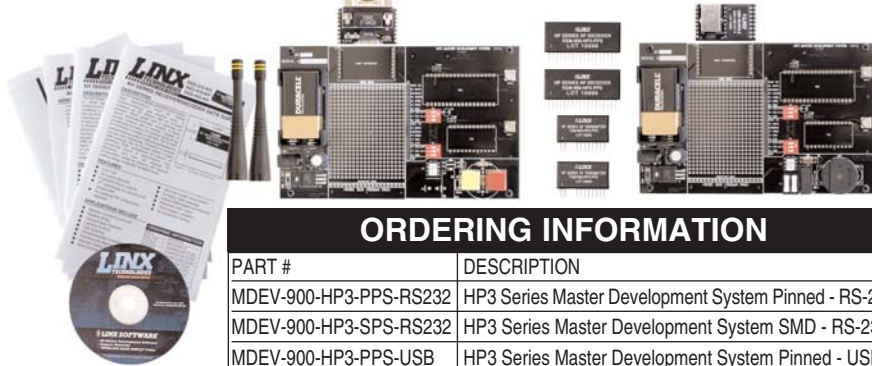

MASTER EVALUATION/DEVELOPMENT SYSTEM

HP3 Series Master Development System User's Guide



ORDERING INFORMATION

PART #	DESCRIPTION
MDEV-900-HP3-PPS-RS232	HP3 Series Master Development System Pinned - RS-232
MDEV-900-HP3-SPS-RS232	HP3 Series Master Development System SMD - RS-232
MDEV-900-HP3-PPS-USB	HP3 Series Master Development System Pinned - USB
MDEV-900-HP3-SPS-USB	HP3 Series Master Development System SMD - USB

INTRODUCTION

The Linx HP3 Series RF modules offer a simple, efficient, and cost-effective method of adding wireless communication capabilities to any product. The Master Development System is intended to give a designer all the tools necessary to correctly and legally incorporate the HP3 Series into an end product. The development boards themselves serve several important functions:

- **Rapid Module Evaluation** - The boards allow the performance of the Linx HP3 Series modules to be evaluated quickly in a user's environment.
- **Range Testing** - By using the on-board encoders and decoders to generate a simplex transmission, a pair of development boards can be used to evaluate the range performance of the modules.
- **Design Benchmark** - During the design process of your product, the boards provide a known benchmark against which the performance of your own design may be judged.
- **Application Development** - An on-board prototyping area is provided to allow a designer to develop applications directly on the development board. All signal lines are available on a header for easy connection to the designer's circuits.
- **Protocol Development** - The development system features two types of Host Interface Modules that allow connection via RS-232 or USB to a PC. Windows-based demonstration software is also included on CD, which allows for a variety of tests.

The Master Development System includes 2 development boards, one set up for the transmitter and the other for the receiver, 2 HP3 Series transmitters*, 2 HP3 Series receivers*, two CW Series antennas, 2 9V batteries, and full documentation.

**One part is soldered to the board, one extra is for use on your first prototype board.*

HP3 SERIES TRANSMITTER DEVELOPMENT BOARD

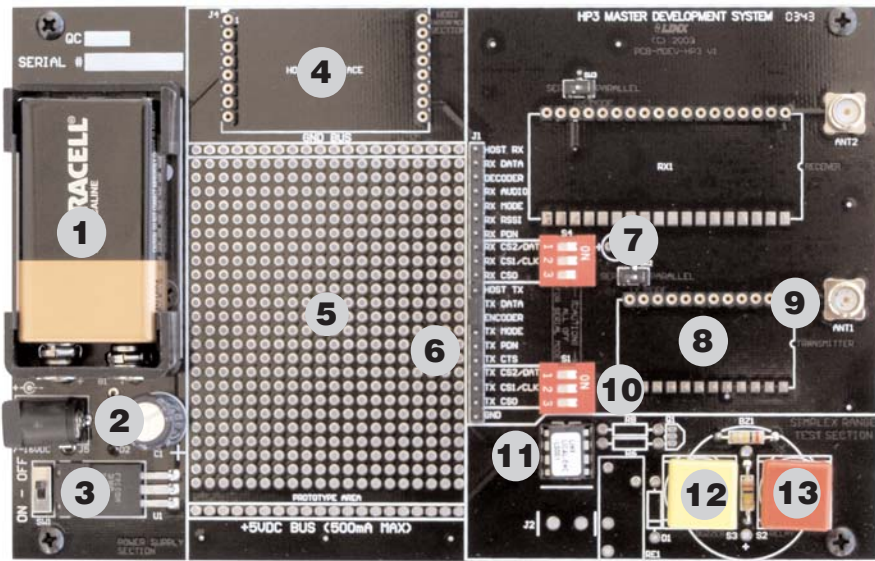

Figure 1: HP3 Series Transmitter Development Board

1. 9V Battery
2. DC Power Jack
3. On-Off Switch
4. Host Interface Header
5. Prototyping Area
6. TX Breakout Header
7. TX Channel Selection Mode Switch
8. HP3 Series Transmitter
9. RP-SMA Antenna Connector
10. TX Channel Selection DIP Switch
11. LS Series Encoder
12. Buzzer Button (S3)
13. Relay Button (S2)

HP3 SERIES RECEIVER DEVELOPMENT BOARD

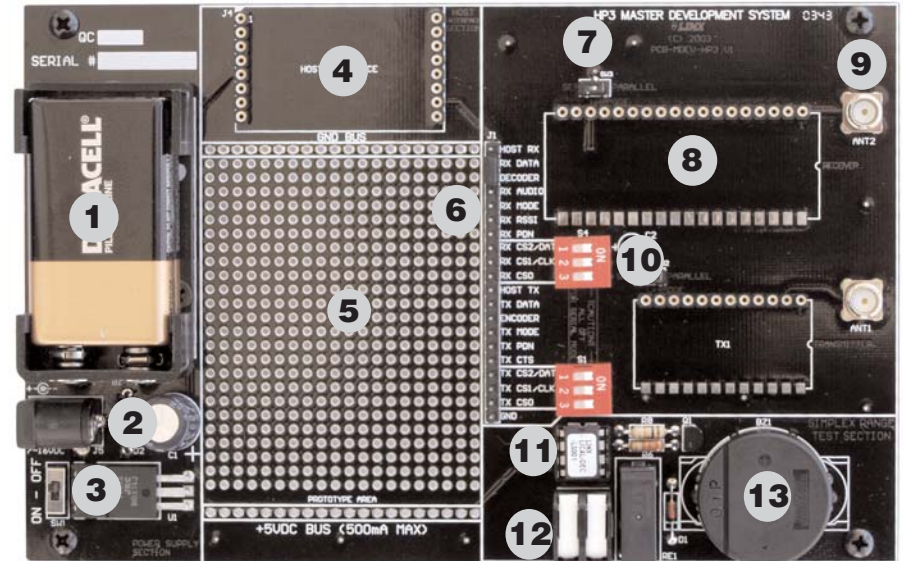

Figure 2: HP3 Series Receiver Development Board

1. 9V Battery
2. DC Power Jack
3. On-Off Switch
4. Host Interface Header
5. Prototyping Area
6. RX Breakout Header
7. RX Channel Selection Mode Switch
8. HP3 Series Receiver
9. RP-SMA Antenna Connector
10. RX Channel Selection DIP Switch
11. LS Series Decoder
12. Relay Output
13. Buzzer

GETTING STARTED

After unpacking the development system, attach an antenna to each board and install the supplied 9V battery. The development boards are now ready for use. The two development boards are very similar and either board can be populated with a transmitter or receiver module. The simplex range testing sections of the boards are populated differently since, in the range testing mode, one board is intended to serve as a transmitter and the other as a receiver.

All of the module's connections are made available to the designer via the breakout header (J1). The supplied jumper shunts are intended to be placed across adjacent pins to control the routing of TX and RX data.

CHANNEL SELECTION

Parallel Selection

All HP3 models feature eight parallel selectable channels. Parallel mode is selected by grounding the module's MODE line (default setting). Mode Switches SW2 (TX) and SW3 (RX) have been provided to allow the developer to easily switch between parallel and serial modes. In parallel mode, channel selection is determined by the logic states of lines CS0, CS1, and CS2, as shown in the adjacent table. DIP switches are used on the development boards to set the channels. If the switch is set to ON, then the pin is connected to ground, otherwise it is pulled up inside the module. The DIP switch positions on both boards must match in order for the modules to communicate.

CS2	CS1	CS0	Channel
0	0	1	0
0	0	0	1
0	1	1	2
0	1	0	3
1	0	1	4
1	0	0	5
1	1	1	6
1	1	0	7
0 = On/Low		1 = Off/High	

Table 1: Channel Selection Table

Serial Selection

In addition to the parallel mode, PS versions of the HP3 also feature 100 serially selectable channels. The serial mode is entered when the MODE line is left open or held high. On the Master Development boards, this is accomplished using the appropriate Mode Switch; SW2 (TX) or SW3 (RX). In this condition CS1 and CS2 become a synchronous serial port with CS1 serving as the clock line and CS2 serving as the data line. The module is then easily programmed by sending and latching the binary number (0-100) of the desired channel. The programming data is supplied externally by the development system user. Often it will originate from a microcontroller or emulator, which can be located in the prototyping area.

Using HP3 modules in serial mode is straightforward; however, minimum timings and bit order must be followed. Please see the HP3 Series Data Guides for these timings.

IMPORTANT The channel selection DIP switch must be in the OFF position in order for the serial lines to be used, otherwise the signal from the microcontroller will be shunted to ground. It is recommended that resistors be placed in series on the data and clock lines to limit current and protect your microcontroller in case the switches are accidentally turned on.

USING THE SIMPLEX ENCODER/DECODER SECTION

The transmitter board features a custom remote-control encoder with two push buttons and the receiver board features a decoder with a relay output and a buzzer. When a button is pressed on the transmitter board, the status of both buttons is captured and encoded into a data stream for transmission. The data recovered by the receiver is decoded and the decoder's data lines are set to replicate the status of the encoder, driving either the buzzer or the relay.

To activate this area of the board, the module data line must be routed to the encoder / decoder. Configure the transmitter board for encoding and transmission by placing a jumper across TX DATA and ENCODER on header J1. Configure the receiver board for reception and decoding by placing a jumper across RX DATA and DECODER on header J1.

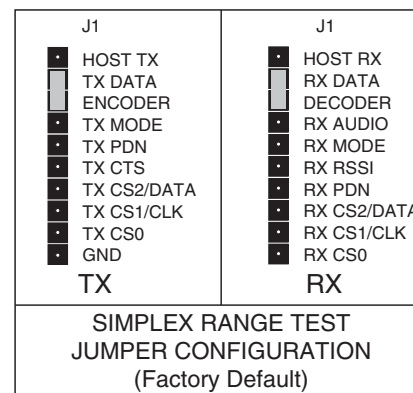

Figure 3: Jumper Configuration

Once the boards have been configured, place the receiver board on a flat surface and turn it on. Turn on the transmitter board and press button S3. You should hear the buzzer on the receiver board sound. You may now walk away from the receiver to ascertain the useable range of the link in your environment.

Another simple but often overlooked range-testing method is to hold down or bridge the buzzer button so that a continuous transmission is made and then walk with the receiver side for testing.

Button S2 activates the relay on the receiver board. The relay's SPST contacts can be connected at J2. Any device up to 5A at 30VDC / 120VAC may be switched through the relay. Most commonly, an external siren or light would be connected to aid range testing if the on-board buzzer is not loud enough.

As you near the maximum range of the link in your area, it is not uncommon for the signal to cut in and out as you move. This is normal and can result from other interfering sources or fluctuating signal levels due to multipath effects. This results in cancellation of the transmitted signal as direct and reflected signals arrive at the receiver at different times and phases. The areas in which this occurs are commonly called "nulls" and simply walking a little farther will often restore the signal.

To achieve maximum range, keep objects such as your hand away from the antenna and ensure that the antenna on the transmitter has a clear and unobstructed line-of-sight path to the receiver board. Range performance is determined by many interdependent factors. If the range you are able to achieve is significantly less than specified by Linx for the products you are testing, then there is likely a problem with either the board or the ambient RF environment in which the board is operating. First, check the battery, switch positions, and antenna connection. Next, measure the receiver's RSSI voltage with the transmitter turned off to determine if ambient interference is present. If this fails to resolve the issue, please contact Linx technical support.

HOST INTERFACE MODULE

The HP3 Master Development System features a Host Interface socket, which allows the use of two different PC interface modules. The first is a USB interface module that uses a standard USB cable (not included) to connect to a PC's USB port or a USB hub. The second type of module is a RS-232 interface module that can be connected to a standard serial COM port on a PC using a straight-through 9-pin extension cable (not included). The evaluation board is considered a DCE device and as such is designed to be connected using a straight-through serial extension cable. Do not use a null-modem cable as the boards will not function.

To install, select the module to be used and then line up the pins on the module with the headers on the board. Verify that the pin one polarity marks on the board and on the Host Interface Module match. The USB jack or the D-sub connector should face away from the board. Press firmly on the module so that it slides fully into the header.

The development system may be prepared for host operation with the supplied Linx software by setting the jumpers on the header as shown in the adjacent figure. This routes the module's data lines to the Host Interface Module. Despite being electrically interfaced, appropriate protocol must be employed to ensure reliable and error-free data transfer since the HP3 Series modules do not encode or packetize the data in any manner. It is important to understand that the development boards are transparent; that is, the user's software is entirely responsible for controlling the timing and error correction aspects of the link. The evaluation boards have no provision to check or qualify the incoming data. When designing a protocol to transfer data across a wireless link, it is very important to remember that interference is inevitable. The protocol must support error detection and correction if it is to be successful. A correctly designed protocol will provide optimum performance and throughput for product-specific applications while taking into account the timing and data-rate requirements of the module. For further information on protocol considerations please refer to Application Note AN-00160.

If the designer needs to develop protocols using a physical implementation other than an RS-232 or USB interface, the designer can build the custom interface circuitry in the prototyping area and route the module's data signals from the header to the prototyping area.

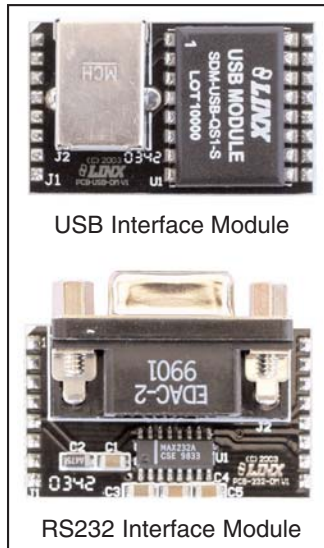

Figure 4: Host Interface Modules

J1	J1
HOST TX	HOST RX
TX DATA	RX DATA
ENCODER	DECODER
TX MODE	RX AUDIO
TX PDN	RX MODE
TX CTS	RX RSSI
TX CS2/DATA	RX PDN
TX CS1/CLK	RX CS2/DATA
TX CS0	RX CS1/CLK
GND	RX CS0
TX	RX
HOST MODE JUMPER CONFIGURATION	

Figure 5: Jumper Configuration

THE PROTOTYPING AREA

A designer wishing to use the development board for product prototyping may route the necessary signals from the development board's breakout header to the prototyping area and then use this to build the custom circuitry.

J1 is a wire-wrap header that is provided as an easy access point to the module's signals. The header pins extend through the board to allow wire attachment on the back of the board.

Regulated power connections are available on the buses labeled "GND" and "+5VDC". The board also has a DC power jack to allow powering from an external power supply rather than with the battery. This jack accepts a 5.5mm plug with the tip ground and the outer shell 7-16VDC positive supply.

NOTE: The on-board 5-volt regulator has approximately 500mA of headroom available for user's circuitry. If additional current capacity is required, the user must add an additional regulator to the prototyping area or power the board from an external supply.

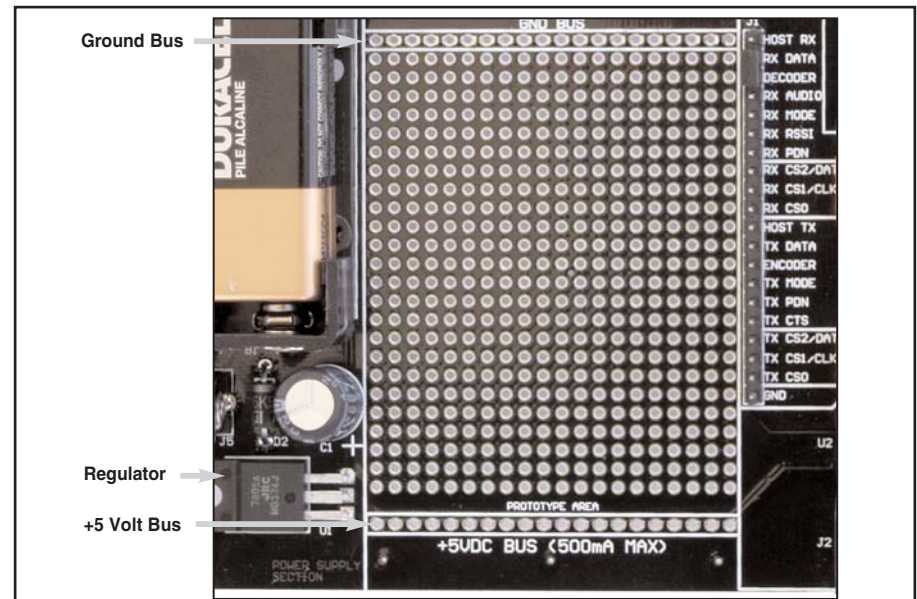

Figure 6: The Prototyping Area

MASTER DEVELOPMENT SOFTWARE

The development system is supplied with Windows-based software that facilitates communication with the development boards through the Host Interface Module. This software allows for testing and illustrates basic implementation of the modules as a wireless serial link. The user selects either a USB or RS232 connection and whether the connected board is the transmitter or receiver. The user can then send text, ASCII characters, and even a picture. Documentation for the software may be found by going to the 'Help' menu then 'Help File'.



Figure 7: Master Development Software

Terminal emulation programs, such as HyperTerminal, do not provide error correction; therefore, bit errors or data line hashing will be displayed as random characters. Some form of error detection should be employed when developing a protocol for wireless environments (please see Application Note AN-00160).

USING THE BOARDS AS A DESIGN REFERENCE

The master development boards included in this kit are very simple, yet they illustrate some important techniques that you may wish to incorporate into your own board layout. You will observe that the HP3 mounting pads (SMD version) extend slightly past the edge of the part. This eases hand assembly and allows for better heat conduction under the part if rework is necessary. Next, observe the use of a full ground plane fill on the lower side of the board. This ground plane serves three important purposes:

First, since a 1/4-wave antenna is employed, the ground plane is critical to serve as a counterpoise (you may wish to read Application Note AN-00500 Antennas: Design, Application, and Performance for additional details on how a ground plane affects antenna function).

Second, a ground plane will suppress the transfer of noise between stages of a product, as well as unintentional radiation of noise into free space.

Third, a ground plane allows for the implementation of a microstrip feed to the antenna. The term microstrip refers to a PCB trace running over a ground plane that is designed to serve as a 50-ohm transmission line between the module and the antenna. A microstrip is implemented on this evaluation board. If you are unfamiliar with microstrip calculations, you may wish to refer to the HP3 Series Data Guides or the calculator available on the Linx Technologies website.

ABOUT ANTENNAS

The choice of antennas is one of the most critical and often overlooked design considerations. The range, performance, and legality of an RF link are critically dependent upon the type of antenna employed. Linx offers a variety of antenna styles that you may wish to consider for your design. Included with your kit is a Linx CW Series connectorized whip antenna that should be connected prior to using the kit. Despite the fact that the antenna is not centered on the board's ground plane, it exhibits a VSWR of <1.7 and suitably demonstrates the module's best practical performance.

ONLINE RESOURCES



www.linxtechnologies.com

- Latest News
- Data Guides
- Application Notes
- Knowledgebase
- Software Updates



If you have questions regarding any Linx product and have Internet access, make www.linxtechnologies.com your first stop. Our website is organized in an intuitive format to immediately give you the answers you need. Day or night, the Linx website gives you instant access to the latest information regarding the products and services of Linx. It's all here: manual and software updates, application notes, a comprehensive knowledgebase, FCC information, and much more. Be sure to visit often!



www.antennafactor.com

The Antenna Factor division of Linx offers a diverse array of antenna styles, many of which are optimized for use with our RF modules. From innovative embeddable antennas to low-cost whips, domes to Yagis, and even GPS, Antenna Factor likely has an antenna for you, or can design one to meet your requirements.



www.connectorcity.com

Through its Connector City division, Linx offers a wide selection of high-quality RF connectors, including FCC-compliant types such as RP-SMAs that are an ideal match for our modules and antennas. Connector City focuses on high-volume OEM requirements, which allows standard and custom RF connectors to be offered at a remarkably low cost.



MAIN DEVELOPMENT BOARD

Power Supply Section

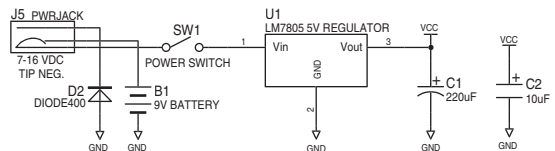

RF Module Section

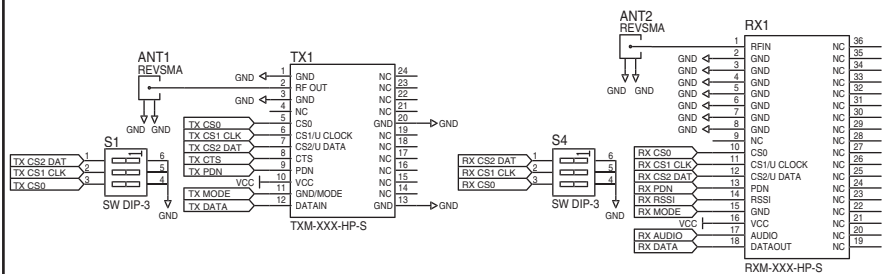

Header Section

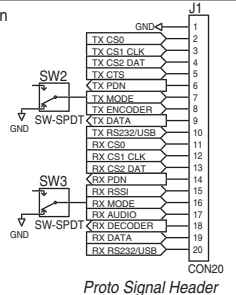

Proto Signal Header

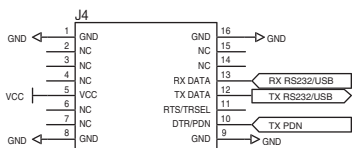

Host Interface Header

Simplex Range Test Section

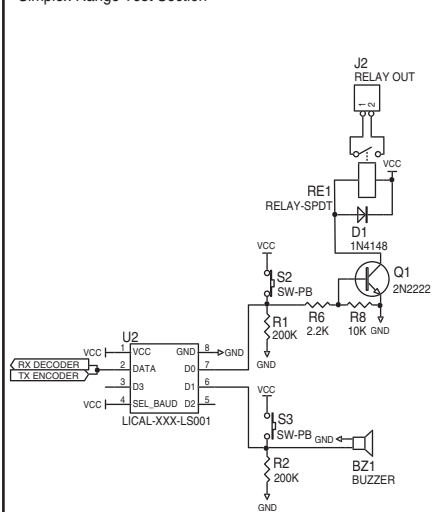

Components Populated For Transmit

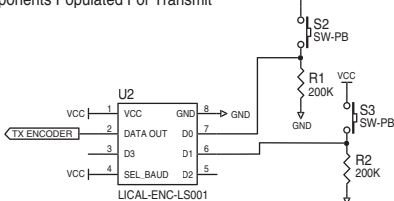

Components Populated For Receive

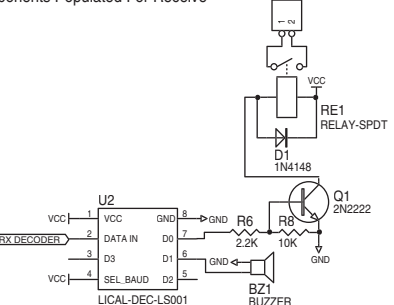

USB HOST INTERFACE BOARD

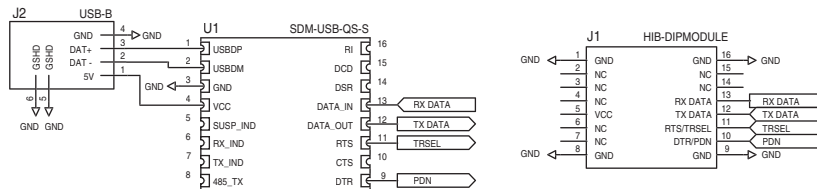

RS232 HOST INTERFACE BOARD

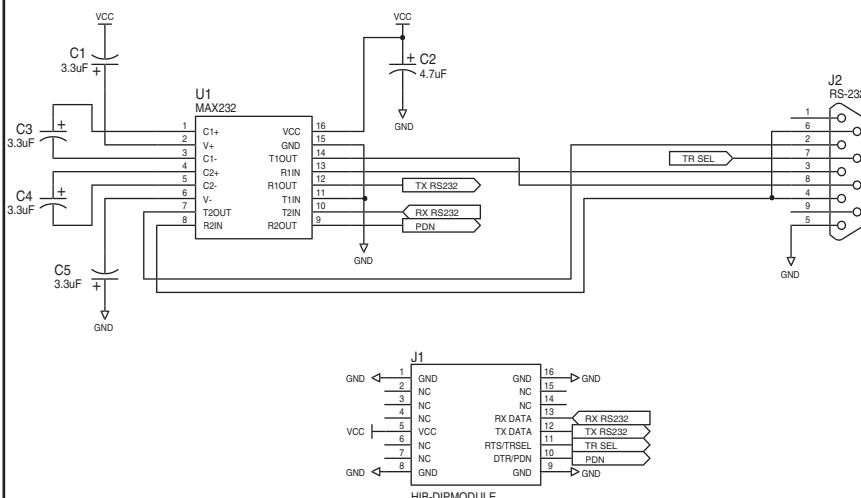



U.S. CORPORATE HEADQUARTERS

LINX TECHNOLOGIES, INC.

**159 ORT LANE
MERLIN, OR 97532**

PHONE: (541) 471-6256

FAX: (541) 471-6251

www.linxtechnologies.com

Disclaimer

Linx Technologies is continually striving to improve the quality and function of its products. For this reason, we reserve the right to make changes to our products without notice. The information contained in this Overview Guide is believed to be accurate as of the time of publication. Specifications are based on representative lot samples. Values may vary from lot-to-lot and are not guaranteed. "Typical" parameters can and do vary over lots and application. Linx Technologies makes no guarantee, warranty, or representation regarding the suitability of any product for use in any specific application. It is the customer's responsibility to verify the suitability of the part for the intended application. NO LINX PRODUCT IS INTENDED FOR USE IN ANY APPLICATION WHERE THE SAFETY OF LIFE OR PROPERTY IS AT RISK.

Linx Technologies DISCLAIMS ALL WARRANTIES OF MERCHANTABILITY AND FITNESS FOR A PARTICULAR PURPOSE. IN NO EVENT SHALL LINX TECHNOLOGIES BE LIABLE FOR ANY OF CUSTOMER'S INCIDENTAL OR CONSEQUENTIAL DAMAGES ARISING IN ANY WAY FROM ANY DEFECTIVE OR NON-CONFORMING PRODUCTS OR FOR ANY OTHER BREACH OF CONTRACT BY LINX TECHNOLOGIES. The limitations on Linx Technologies' liability are applicable to any and all claims or theories of recovery asserted by Customer, including, without limitation, breach of contract, breach of warranty, strict liability, or negligence. Customer assumes all liability (including, without limitation, liability for injury to person or property, economic loss, or business interruption) for all claims, including claims from third parties, arising from the use of the Products. The Customer will indemnify, defend, protect, and hold harmless Linx Technologies and its officers, employees, subsidiaries, affiliates, distributors, and representatives from and against all claims, damages, actions, suits, proceedings, demands, assessments, adjustments, costs, and expenses incurred by Linx Technologies as a result of or arising from any Products sold by Linx Technologies to Customer. Under no conditions will Linx Technologies be responsible for losses arising from the use or failure of the device in any application, other than the repair, replacement, or refund limited to the original product purchase price. Devices described in this publication may contain proprietary, patented, or copyrighted techniques, components, or materials. Under no circumstances shall any user be conveyed any license or right to the use or ownership of such items.



Стандарт Электрон Связь

Мы молодая и активно развивающаяся компания в области поставок электронных компонентов. Мы поставляем электронные компоненты отечественного и импортного производства напрямую от производителей и с крупнейших складов мира.

Благодаря сотрудничеству с мировыми поставщиками мы осуществляем комплексные и плановые поставки широчайшего спектра электронных компонентов.

Собственная эффективная логистика и склад в обеспечивает надежную поставку продукции в точно указанные сроки по всей России.

Мы осуществляем техническую поддержку нашим клиентам и предпродажную проверку качества продукции. На все поставляемые продукты мы предоставляем гарантию .

Осуществляем поставки продукции под контролем ВП МО РФ на предприятия военно-промышленного комплекса России , а также работаем в рамках 275 ФЗ с открытием отдельных счетов в уполномоченном банке. Система менеджмента качества компании соответствует требованиям ГОСТ ISO 9001.

Минимальные сроки поставки, гибкие цены, неограниченный ассортимент и индивидуальный подход к клиентам являются основой для выстраивания долгосрочного и эффективного сотрудничества с предприятиями радиоэлектронной промышленности, предприятиями ВПК и научно-исследовательскими институтами России.

С нами вы становитесь еще успешнее!

Наши контакты:

Телефон: +7 812 627 14 35

Электронная почта: sales@st-electron.ru

Адрес: 198099, Санкт-Петербург,
Промышленная ул, дом № 19, литера Н,
помещение 100-Н Офис 331