



Quick Start Guide

**SABRE Platform for Smart Devices
Based on the i.MX 6 Series**



About the SABRE Platform for Smart Devices Based on the i.MX 6 Series

The Smart Application Blueprint for Rapid Engineering (SABRE) platform for smart devices is the latest in a series of high-performance, highly integrated development kits from Freescale that introduce designers to market-focused uses of the i.MX 6 series applications processor.

The SABRE platform for smart devices can be targeted towards any device requiring an intelligent display, connectivity, low power consumption and an amazing user experience, and comes equipped with either an i.MX 6Quad processor or an i.MX 6DualLite processor. Included with the design are links to the hardware design files, tools and board support packages (BSP) for Linux® and Android™ along with bootable Android image on an SD card to get you up and running quickly.

The following features are available with the SABRE platform for smart devices based on the i.MX 6 series:

- i.MX 6Quad processor 1 GHz or i.MX 6DualLite processor 1 GHz
- 1 GB DDR3 533 MHz
- 10" LVDS display panel with capacitive touch screen
- 8 GB eMMC iNAND
- Two SD card slots
- SATA 22-pin connector
- HDMI connector
- Secondary LVDS connector
- LCD expansion port connector
- EPDC expansion port connector
- Two five-megapixel cameras
- Two 3.5 mm audio ports (stereo HP and microphone)
- Two board-mounted digital microphones
- External stereo speakers
- 4 MB SPI NOR flash
- USB OTG connector
- Debug out via USB μ AB device connector
- Gigabit Ethernet connector
- JTAG 20-pin connector
- mPCIe connector
- GPS module with antenna
- Sensor package including:
 - 3-axis accelerometer
 - Digital compass
 - Ambient light sensor

Get to Know SABRE Platform for Smart Devices Based on the i.MX 6 Series

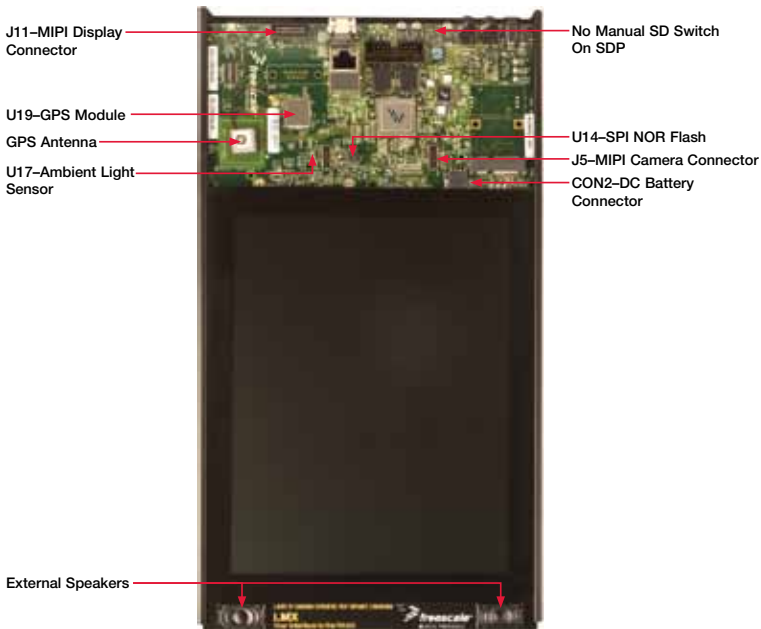

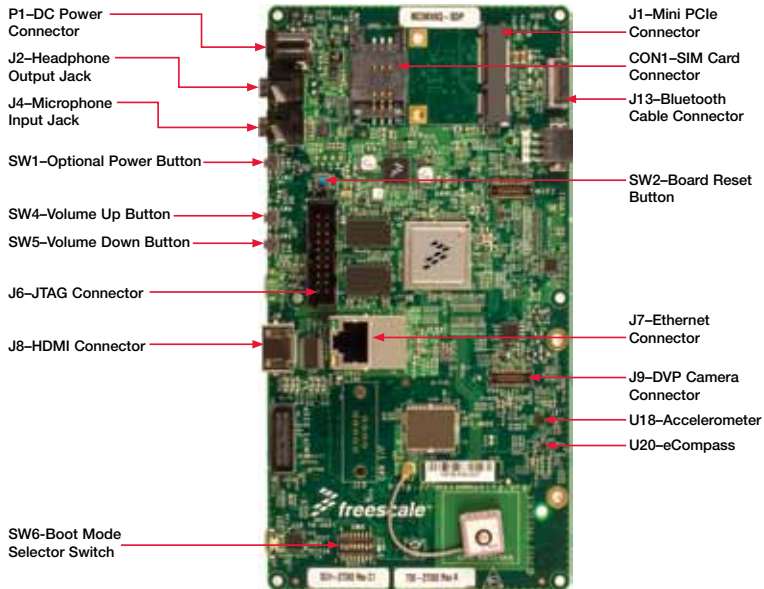

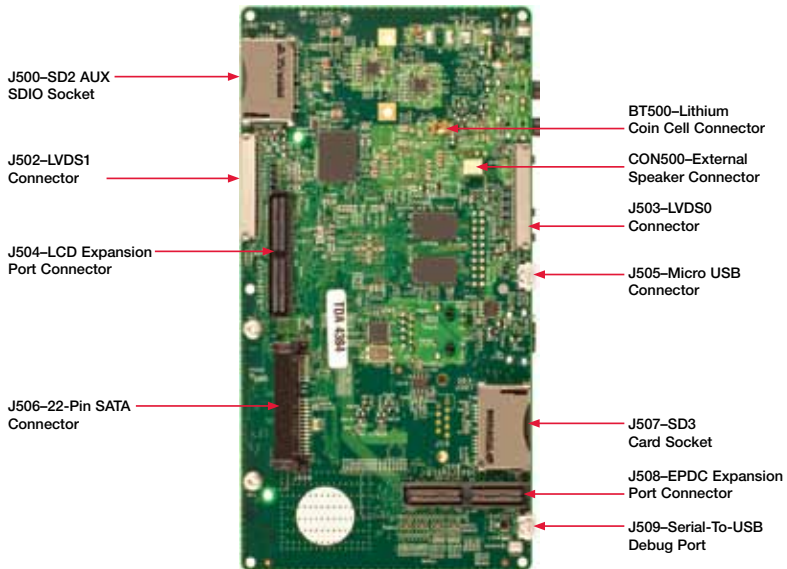

Getting Started

This section describes how to use the SABRE platform for smart devices board and kit components. This section also describes the PC requirements to develop applications using the platform.

1 Unpacking the Kit

The SABRE platform for smart devices is shipped with the items listed in Table 1. Ensure the items listed in Table 1 are available in the i.MX 6 series development kit. Remove the platform from the antistatic bag and perform a visual inspection.

Table 1: SABRE Platform for Smart Devices Based on i.MX 6 Series Development Kit Contents

Item	Description
Smart device platform	Main board, LVDS display and speaker board, pre-assembled
Cable	USB cable (micro-B to standard-A)
Power supply	5 V/5 A universal power supply
Documentation	Quick start guide (this document)
8 GB SD card	Bootable demonstration code for smart device platform

2

Download Software and Tools

Download installation software and documentation under **“Jump Start Your Design”** at freescale.com/SABRESDP. Table 2 lists the documents available on the kit website.



Table 2: “Jump Start Your Design” Contents

Item	Description
SABRE platform for smart devices documentation	<ul style="list-style-type: none"> • Schematics, layout and Gerber files • SABRE platform for smart devices quick start guide (this document)
Software development tools	Android and Linux BSPs
SABRE platform for smart devices demo images	Copy of the Android image provided on the SD card

Setting up the System

1 Insert SD Card

Insert the supplied SD card into socket SD3.

2 Connect USB Debug Cable (Optional)

Connect the micro-B end of the supplied USB cable into debug port J509. Connect the other end of the cable to a PC acting as a host terminal. If needed, the serial-to-USB drivers can be found at ftdichip.com/FTDrivers.htm.

Terminal window configuration:
115.2 kbaud, 8 data bits, 1 stop bit, no parity.

3 Connect Ethernet Cable (Optional)

Connect an Ethernet cable to the Ethernet jack J7.

4 Connect Power Supply

Connect the 5 V power supply cable to the 5 V DC power jack P1. When power is connected to the smart device, it will automatically begin the boot sequence.

Boot Process for Android Image

1 Boot Process

Insert the supplied SD card into socket SD3.

- During the boot process, there will be operating system status information scrolling on the terminal window of the PC (if connected). The Linux penguin images will initially appear in the upper left corner of the display, one for each operating ARM® core.
- When the boot process is complete, the Android operating system will be displayed.
- To work from the terminal window on the host PC, press enter at the terminal window to get the command prompt.

**Table 3: SABRE Platform for Smart Devices
DIP Switch Configuration (SW6)**

D1	D2	D3	D4	D5	D6	D7	D8
Off	On	Off	Off	Off	Off	On	Off

Switch Functions

Table 4 shows the functions of the four push button switches on the board.

Table 4: SABRE Platform for Smart Devices Button Operations

Item	Description
POWER SW1	SABRE platform for smart devices POWER button <ul style="list-style-type: none"> • Momentary depress of button will place the system in standby. • Long press of the button will display a software drive shutdown option menu. • Prolonged depress (> 5 sec.) will force an immediate hardware shutdown. • If board is in the OFF state, momentary depress of button will restart (boot) the system. • If board is in the STANDBY state, momentary depress of the button will bring the system out of standby (resume operations, no boot)
RESET SW2	SABRE platform for smart devices RESET button <ul style="list-style-type: none"> • Momentary depress of button will reset the system and begin a boot sequence.
Volume up SW4	Volume +
Volume down SW5	Volume -



Get Started

Download installation software and documentation under
“**Jump Start Your Design**” at freescale.com/SABRESDP.

Support

Visit the i.MX community at imxcommunity.org.

Warranty

Visit freescale.com/warranty for complete warranty information.

For more information, visit
freescale.com/imxSABRE

Freescale and the Freescale logo are trademarks of Freescale semiconductor, Inc., Reg. U.S. Pat. & Tm. Off. ARM is a registered trademark of ARM Limited. ARM Cortex-A9 is a trademark of ARM Limited. All other product or service names are the property of their respective owners. © 2012 Freescale Semiconductor, Inc.



Doc Number: IMX6QSDPQSG REV 0
Agile Number: 926-27392 REV A



Стандарт Электрон Связь

Мы молодая и активно развивающаяся компания в области поставок электронных компонентов. Мы поставляем электронные компоненты отечественного и импортного производства напрямую от производителей и с крупнейших складов мира.

Благодаря сотрудничеству с мировыми поставщиками мы осуществляем комплексные и плановые поставки широчайшего спектра электронных компонентов.

Собственная эффективная логистика и склад в обеспечивает надежную поставку продукции в точно указанные сроки по всей России.

Мы осуществляем техническую поддержку нашим клиентам и предпродажную проверку качества продукции. На все поставляемые продукты мы предоставляем гарантию .

Осуществляем поставки продукции под контролем ВП МО РФ на предприятия военно-промышленного комплекса России , а также работаем в рамках 275 ФЗ с открытием отдельных счетов в уполномоченном банке. Система менеджмента качества компании соответствует требованиям ГОСТ ISO 9001.

Минимальные сроки поставки, гибкие цены, неограниченный ассортимент и индивидуальный подход к клиентам являются основой для выстраивания долгосрочного и эффективного сотрудничества с предприятиями радиоэлектронной промышленности, предприятиями ВПК и научно-исследовательскими институтами России.

С нами вы становитесь еще успешнее!

Наши контакты:

Телефон: +7 812 627 14 35

Электронная почта: sales@st-electron.ru

Адрес: 198099, Санкт-Петербург,
Промышленная ул, дом № 19, литера Н,
помещение 100-Н Офис 331