

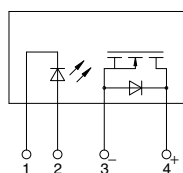

**Max. high capacity 10A  
in a slim SIL package**

**PhotoMOS<sup>®</sup>  
Power 1 Form A  
DC High Capacity (AQZ19○)**

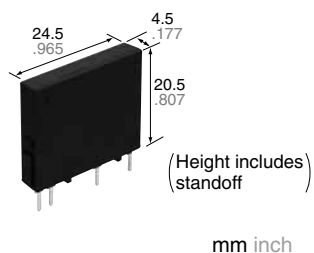

**RoHS compliant**

### FEATURES

- 1. High capacity type power PhotoMOS.**  
Can switch a wide range of currents and voltages. Can control various types of loads, from very small loads to a max. 10 A DC current for sequencers, motors, and lamps.
- 2. Low on-resistance and high sensitivity.**  
Low on-resistance of less than Typ. 8 mΩ (AQZ192). High sensitivity LED operate current of Typ. 0.7 mA.
- 3. 4-pin SIL type (Thickness: Max. 4.5 mm .177 inch)**  
(L) 24.5 mm × (W) 4.5 mm × (H) 20.5 mm  
(L) .965 inch × (W) .177 inch × (H) .807 inch.
- 4. Low-level off state leakage current of max. 10 μA**
- 5. Controls low-level analog signals**  
The triac, photocoupler, or SSR cannot be used to control signals of less than several hundred mV. The high capacity type power PhotoMOS feature extremely low closed-circuit offset voltage to enable control of low-level analog signals without distortion.

### TYPICAL APPLICATIONS

- Photovoltaic power generation system
- Battery system
- Measuring instruments
- Power supply unit
- Industrial machines

### TYPES

	Output rating*		Package	Part No.	Packing quantity	
	Load voltage	Load current			Inner carton	Outer carton
DC only	60 V	10 A	SIL4-pin	AQZ192	20 pcs	500 pcs
	200 V	5 A		AQZ197		

Note: Please refer to the cautions for use regarding the recommended operation load voltage.

\*Load voltage and load current of DC type: DC

### RATING

#### 1. Absolute maximum ratings (Ambient temperature: 25°C 77°F)

Item		Symbol	AQZ192	AQZ197	Remarks
Input	LED forward current	I <sub>F</sub>	50 mA		
	LED reverse voltage	V <sub>R</sub>	5 V		
	Peak forward current	I <sub>FP</sub>	1 A		f = 100Hz, Duty factor = 0.1%
	Power dissipation	P <sub>in</sub>	75 mW		
Output	Load voltage (DC)	V <sub>L</sub>	60 V	200 V	
	Continuous load current (DC)	I <sub>L</sub>	10 A	5 A	
	Peak load current	I <sub>peak</sub>	30 A	15 A	100 ms (1shot), V <sub>L</sub> = DC
	Power dissipation	P <sub>out</sub>	2.0 W		
Total power dissipation		P <sub>T</sub>	2.0 W		
I/O isolation voltage		V <sub>iso</sub>	3,000 Vrms		
Ambient temperature	Operating	T <sub>opr</sub>	-40 to +85°C -40 to +185°F		(Non-icing at low temperatures)
	Storage	T <sub>stg</sub>	-40 to +100°C -40 to +212°F		

# Power 1 Form A DC High Capacity (AQZ19)

## 2. Electrical characteristics (Ambient temperature: 25°C 77°F)

Item		Symbol	AQZ192	AQZ197	Condition
Input	LED operate current	Typical	0.7 mA		$I_L = 100 \text{ mA}$ $V_L = 10 \text{ V}$
		Maximum	3.0 mA		
	LED turn off current	Minimum	0.2 mA		
		Typical	0.5 mA		
LED dropout voltage	Typical	1.35 V (1.17 V at $I_F = 10 \text{ mA}$ )		$I_F = 50 \text{ mA}$	
	Maximum	1.5 V			
Output	On resistance	Typical	8 mΩ	31 mΩ	$I_F = 10 \text{ mA}$ , $I_L = \text{Max.}$ Within 1 s
		Maximum	15 mΩ	50 mΩ	
	Off state leakage current	Maximum	10 μA		
Transfer characteristics	Turn on time*	Typical	1.0 ms	0.7 ms	$I_F = 10 \text{ mA}$ , $I_L = 100 \text{ mA}$ , $V_L = 10 \text{ V}$
		Maximum	3.0 ms		
	Turn off time*	Typical	0.11 ms	0.05 ms	$I_F = 10 \text{ mA}$ , $I_L = 100 \text{ mA}$ , $V_L = 10 \text{ V}$
		Maximum	1.0 ms		
	I/O capacitance	Typical	1.3 pF		$f = 1 \text{ MHz}$ , $V_B = 0 \text{ V}$
		Maximum	3.0 pF		
Initial I/O isolation resistance	Minimum	$R_{iso}$	1,000 MΩ		500 V DC
Max. operating frequency	Maximum	—	0.5 cps		$I_F = 10 \text{ mA}$ , Duty factor = 50%, $V_L = \text{Max.}$ , $I_L = \text{Max.}$

\*Turn on/off time

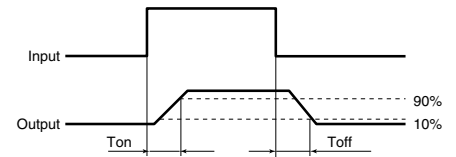

## 3. Recommended operating conditions (Ambient temperature: 25°C 77°F)

Please use under recommended operating conditions to obtain expected characteristics.

Item		Symbol	Min.	Max.	Unit
LED current		$I_F$	10	30	mA
AQZ192	Load voltage (Peak AC)	$V_L$	—	48	V
	Continuous load current	$I_L$	—	10	A
AQZ197	Load voltage (Peak AC)	$V_L$	—	160	V
	Continuous load current	$I_L$	—	5	A

■ These products are not designed for automotive use.

If you are considering to use these products for automotive applications, please contact your local Panasonic Corporation technical representative.

## REFERENCE DATA

1. Load current vs. ambient temperature characteristics

Allowable ambient temperature: -40 to +85°C  
-40 to +185°F

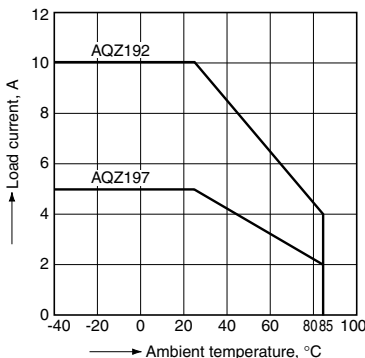

2. Load current vs. ambient temperature characteristics in adjacent mounting

Sample: All types  
 $I_L$ : Load current;  
 $I_L$  (max.): Maximum continuous load current

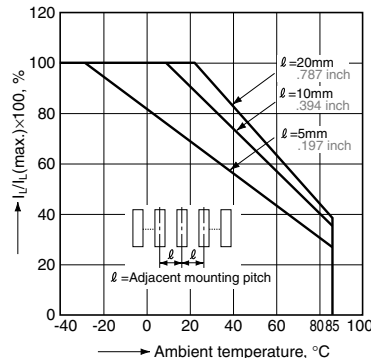

3. On resistance vs. ambient temperature characteristics

LED current: 10 mA;  
Continuous load current: 10 A DC (AQZ192)  
5 A DC (AQZ197)

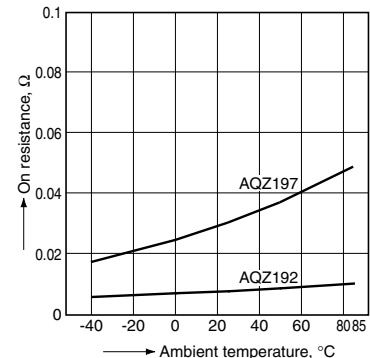

## 4. Turn on time vs. ambient temperature characteristics

LED current: 10 mA; Load voltage: 10 V (DC);  
Continuous load current: 100 mA (DC)

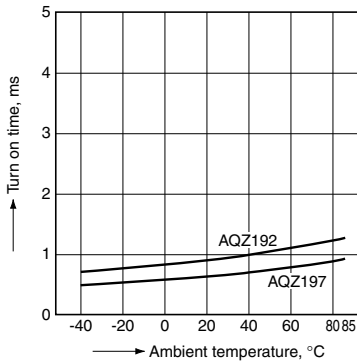

## 5. Turn off time vs. ambient temperature characteristics

LED current: 10 mA; Load voltage: 10 V (DC);  
Continuous load current: 100 mA (DC)

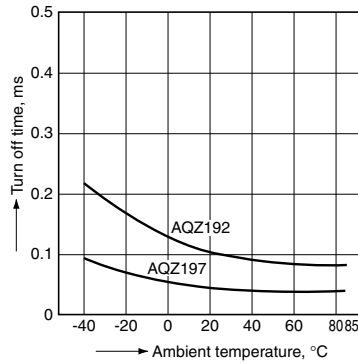

## 6. LED operate current vs. ambient temperature characteristics

Sample: All types  
Load voltage: 10 V (DC);  
Continuous load current: 100 mA (DC)

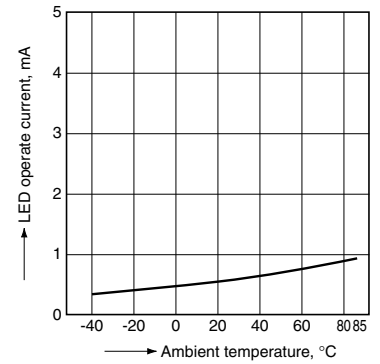

## 7. LED turn off current vs. ambient temperature characteristics

Sample: All types  
Load voltage: 10 V (DC);  
Continuous load current: 100 mA (DC)

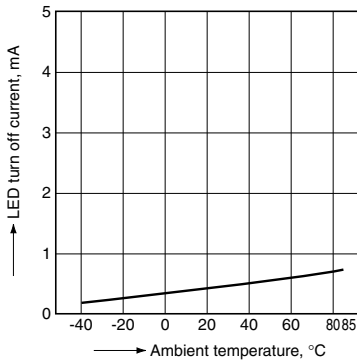

## 8. LED dropout voltage vs. ambient temperature characteristics

Sample: All types  
LED current: 5 to 50 mA

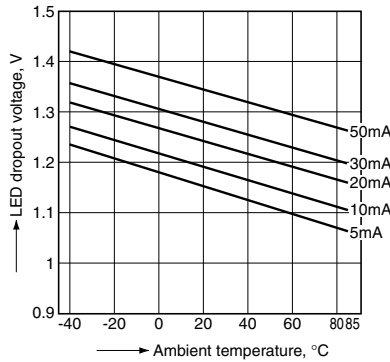

## 9. Current vs. voltage characteristics of output at MOS portion

Ambient temperature: 25°C 77°F

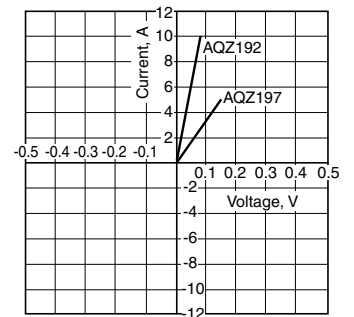

## 10. Off state leakage current vs. load voltage characteristics

Ambient temperature: 25°C 77°F

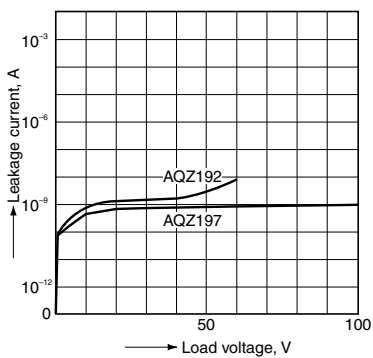

## 11. Turn on time vs. LED forward current characteristics

Load voltage: 10 V (DC);  
Continuous load current: 100 mA (DC);  
Ambient temperature: 25°C 77°F

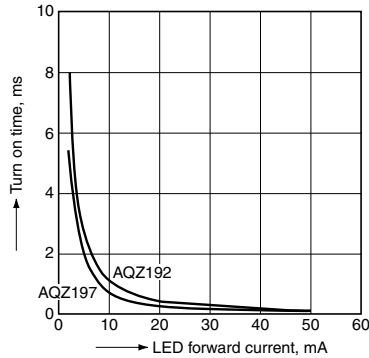

## 12. Turn off time vs. LED forward current characteristics

Load voltage: 10 V (DC);  
Continuous load current: 100 mA (DC);  
Ambient temperature: 25°C 77°F

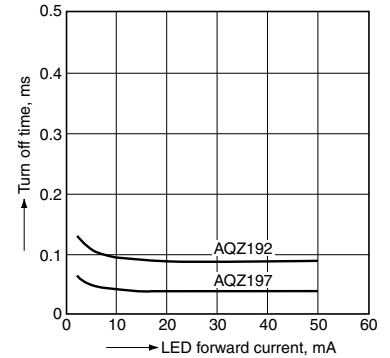

# Power 1 Form A DC High Capacity (AQZ19)

## 13. Max. operating frequency vs. load voltage/current characteristics

Sample: All types; LED current: 10 mA;  
Ambient temperature: 25°C 77°F

$V_L$ : Load voltage,  $V_L$  (Max.): Max. rated load voltage  
 $I_L$ : Load current,  $I_L$  (Max.): Max. rated continuous load current

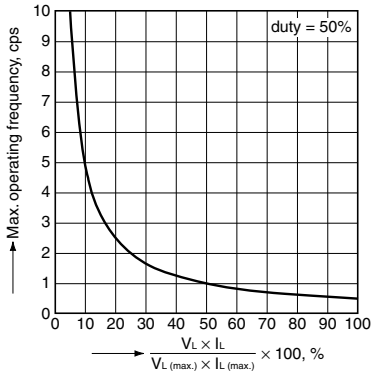

## 14. Output capacitance vs. applied voltage characteristics

Frequency: 1 MHz; Ambient temperature: 25°C 77°F

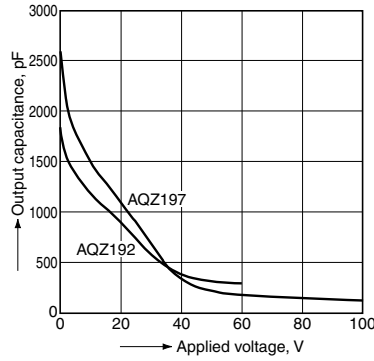

## DIMENSIONS (mm inch)



The CAD data of the products with a **CAD** mark can be downloaded from: <http://industrial.panasonic.com/ac/e/>

### External dimensions

### PC board pattern (Bottom view)

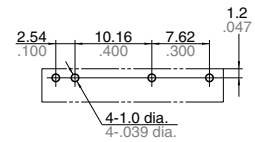
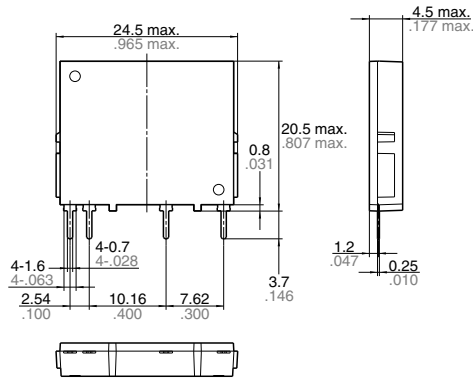

Tolerance:  $\pm 0.1 \pm 0.004$

### Schematic

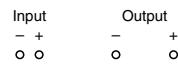

General tolerance:  $\pm 0.2 \pm 0.008$

"PhotoMOS®", "PhotoMOS" and "PHOTOMOS" are registered trademarks of Panasonic Corporation.

\*Recognized in Japan, the United States, all member states of European Union and other countries.

Please contact .....

**Panasonic Corporation**

Electromechanical Control Business Division

■ 1006, Oaza Kadoma, Kadoma-shi, Osaka 571-8506, Japan  
[industrial.panasonic.com/ac/e/](http://industrial.panasonic.com/ac/e/)

**Panasonic®**

©Panasonic Corporation 2017

# Mouser Electronics

Authorized Distributor

Click to View Pricing, Inventory, Delivery & Lifecycle Information:

[Panasonic:](#)

[AQZ197](#)



## Стандарт Электрон Связь

Мы молодая и активно развивающаяся компания в области поставок электронных компонентов. Мы поставляем электронные компоненты отечественного и импортного производства напрямую от производителей и с крупнейших складов мира.

Благодаря сотрудничеству с мировыми поставщиками мы осуществляем комплексные и плановые поставки широчайшего спектра электронных компонентов.

Собственная эффективная логистика и склад в обеспечивает надежную поставку продукции в точно указанные сроки по всей России.

Мы осуществляем техническую поддержку нашим клиентам и предпродажную проверку качества продукции. На все поставляемые продукты мы предоставляем гарантию .

Осуществляем поставки продукции под контролем ВП МО РФ на предприятия военно-промышленного комплекса России , а также работаем в рамках 275 ФЗ с открытием отдельных счетов в уполномоченном банке. Система менеджмента качества компании соответствует требованиям ГОСТ ISO 9001.

Минимальные сроки поставки, гибкие цены, неограниченный ассортимент и индивидуальный подход к клиентам являются основой для выстраивания долгосрочного и эффективного сотрудничества с предприятиями радиоэлектронной промышленности, предприятиями ВПК и научно-исследовательскими институтами России.

С нами вы становитесь еще успешнее!

### Наши контакты:

**Телефон:** +7 812 627 14 35

**Электронная почта:** [sales@st-electron.ru](mailto:sales@st-electron.ru)

**Адрес:** 198099, Санкт-Петербург,  
Промышленная ул, дом № 19, литера Н,  
помещение 100-Н Офис 331