



MAX2660/MAX2661/MAX2663/MAX2671 Evaluation Kits

General Description

The MAX2660/MAX2661/MAX2663/MAX2671 evaluation kits simplify evaluation of the MAX2660/MAX2661/MAX2663/MAX2671 upconverter mixers. They enable testing of all the functions, with no additional support circuitry. Signal inputs and outputs use SMA connectors and are compatible with the 50Ω impedance of test equipment.

Each EV kit is shipped with a Maxim device configured for operation with an IF input frequency of 40MHz to 500MHz, and LO input frequency of 600MHz to 2400MHz. The output matching network of each kit is optimized for an RF output frequency of 900MHz.

Component List

DESIGNATION	QTY	DESCRIPTION
COMPONENTS COMMON TO ALL EVALUATION KITS		
C1, C2, C5, C8, C9	5	220pF ±10% (0603) NPO ceramic capacitors
C3, C4, C7	3	47pF ±10% (0603) NPO ceramic capacitors
C10	1	10μF ±20%, 6.3V A-size tantalum capacitor
J1, J2, J3	3	SMA connectors
JU1	1	3-pin header, 0.025" sq., 0.10" centers
L1	1	33nH inductor
L2	1	18nH inductor
R1	1	100Ω 5% (0603) resistor
MAX2660 EV KIT ADDITIONAL COMPONENTS		
C6	1	1pF ±0.1pF (0603) NPO ceramic capacitor
U1	1	MAX2660, SOT23-6, upconverter mixer
MAX2661 EV KIT ADDITIONAL COMPONENTS		
C6	1	1pF ±0.1pF (0603) NPO ceramic capacitor
U1	1	MAX2661, SOT23-6, upconverter mixer
MAX2663 EV KIT ADDITIONAL COMPONENTS		
C6	1	1.8pF ±0.1pF (0603) NPO ceramic capacitor
U1	1	MAX2663, SOT23-6, upconverter mixer
MAX2671 EV KIT ADDITIONAL COMPONENTS		
C6	1	1pF ±0.1pF (0603) NPO ceramic capacitor
U1	1	MAX2671, SOT23-6, upconverter mixer

Features

- ◆ +2.7V to +5.5V Single Supply
- ◆ Output Matched to 50Ω at 900MHz
- ◆ Optimal Component Placement
- ◆ Easy Evaluation of All Product Functions
- ◆ All Critical Peripheral Components Included

Ordering Information

PART	TEMP. RANGE	PIN-PACKAGE
MAX2660EVKIT-T	-40°C to +85°C	6 SOT23-6
MAX2661EVKIT-T	-40°C to +85°C	6 SOT23-6
MAX2663EVKIT-T	-40°C to +85°C	6 SOT23-6
MAX2671EVKIT-T	-40°C to +85°C	6 SOT23-6

Component Suppliers

SUPPLIER	PHONE	FAX
AVX	803-946-0690	803-626-3123
Toko	847-297-0700	847-699-7864

Quick Start

Each EV kit is fully assembled and factory tested. Follow the instructions in the *Connections and Setup* section.

Test Equipment Required

EQUIPMENT	DESCRIPTION
DC Power Supply	Capable of supplying +2.7V to +5.5V at a minimum of 50mA
HP 8561E Spectrum Analyzer	Or equivalent high-sensitivity spectrum analyzer
Digital multimeters	To monitor supply voltage and supply current (if desired)
HP 8648C RF Generators, 2	For the IFIN and LO inputs or equivalent sine-wave sources

Evaluates: MAX2660/MAX2661/MAX2663/MAX2671

MAX2660/MAX2661/MAX2663/MAX2671 Evaluation Kits

Connections and Setup

- 1) Verify the DC power supply is set to less than +5.5V before attaching the supply to the EV kit. A good starting voltage is +3.0V.
- 2) Verify the SHDN jumper is in the "VCC" position.
- 3) Connect a signal generator to the IFIN connector using an SMA cable. As with any precision RF connector, be careful while threading the connector. For optimal performance, consult the connector manufacturer's specifications for torque recommendation. Set the generator's output to 70MHz at -30dBm power level.
- 4) Connect a second signal generator to the LO input connector using an SMA cable. Set the generator's output to 970MHz at -5dBm power level (use -10dBm for the MAX2671 EV Kit).
- 5) Connect the RF output of the EV kit to the spectrum analyzer using an SMA cable. Take care to use quality connector adapters for the spectrum analyzer's input. Avoid using BNC-type connectors due to their high VSWR while operating in the gigahertz range.
- 6) To assist in troubleshooting, verify the correct voltages on the PC board with a multimeter. Use Table 1 to verify correct node voltage during proper operation.

Table 1. Nominal DC Voltages

PIN NUMBER	PIN NAME	NOMINAL DC VOLTAGE (V)
1	LO	(V _{CC} - 0.4) to (V _{CC} - 1.0)
2	GND	0
3	IFIN	+1.37
4	RF OUT	V _{CC}
5	V _{CC}	+2.7 to +5.5
6	SHDN	V _{CC} for normal operation

Analysis

- 1) Set the spectrum analyzer's center frequency to 900MHz, with a span of 30MHz.
- 2) Set the marker position to the peak level.
- 3) Read the output power of the center frequency. This should be -28dBm to -21dBm, depending on which device is used. The output frequency is equal to the algebraic difference of the LO and IF frequencies. The power is equal to the IFIN input power plus the conversion gain of the upconverter mixer. See Table 2 for the typical conversion gain of each device.

Table 2. Typical Conversion Gain

PART	CONVERSION GAIN (dB) AT 900MHz
MAX2660	+7.0
MAX2661	+10.7
MAX2663	+3.4
MAX2671	+11.2

Detailed Description

Figure 1 is the schematic for the EV kit as shipped. The output matching components, L1, L2, C5, and C6, are optimized for an output frequency of 900MHz. Capacitors C1 and C2 are DC blocking capacitors for the IFIN and LO input ports. To reduce the possibility of noise pickup, resistor R1 and capacitor C8 form a low-pass filter at the SHDN pin.

Capacitors C3, C4, C7, C9, and C10 form the V_{CC} decoupling network. Note the location of each component. Capacitor C10, a 10μF tantalum type, is located near the V_{CC} input test point. This serves as the central node for distribution of V_{CC} to the mixer's supply pin and the output pull-up inductor L2. Both of these supply points need separate bypass capacitors as well as separate traces on the PC board. This is prudent practice to curtail crosstalk in high-frequency systems.

Modifying the EV Kit

The EV kit is easily configured for use with any of the MAX2660/MAX2661/MAX2663/MAX2671 devices. Each of these devices offers different performance levels for system optimization.

Changing to Different Devices

To configure the EV kit for a different device, use appropriate surface-mount rework equipment to remove the existing IC from the PCB. Take care to ensure that the package temperature does not exceed the limits listed in the *Absolute Maximum Ratings* section of the MAX2660/MAX2661/MAX2663/MAX2671/MAX2673 data sheet. Install the new device using appropriate surface-mount equipment and techniques. See Table 3 for the correct component values for the desired operating frequency and device type.

Operation at Other Frequencies

Changing the EV kit to operate at frequencies other than listed in Table 3 involves matching each device's output impedance to 50Ω at the frequency of interest.

MAX2660 Evaluation Kit

Table 3. Output Matching Components vs. RF Output Frequency

PART	COMPONENT	COMPONENT VALUE AT A GIVEN RF OUTPUT FREQUENCY (MHz)			
		AT 400	AT 900	AT 1900	AT 2450
MAX2660	L1 (nH)	Short	33	8.2	3.3
	L2 (nH)	39	18	2.7	2.2
	C3 (pF)	220	47	47	47
	C4 (pF)	220	47	47	47
	C5 (pF)	3300	220	220	15
	C6 (pF)	6.8	1	1.5	Open
	C7 (pF)	470	47	47	47
MAX2661	L1 (nH)	Short	33	8.2	3.3
	L2 (nH)	39	18	2.7	1.8
	C3 (pF)	470	47	47	47
	C4 (pF)	220	47	47	47
	C5 (pF)	3300	220	100	220
	C6 (pF)	6.8	1	1.5	Open
	C7 (pF)	470	47	47	47
MAX2663	L1 (nH)	Short	33	8.2	3.3
	L2 (nH)	39	18	1.8	1.8
	C3 (pF)	220	47	47	47
	C4 (pF)	220	47	47	47
	C5 (pF)	3300	220	100	220
	C6 (pF)	6.8	1.8	1.8	Open
	C7 (pF)	220	47	47	47
MAX2671	L1 (nH)	Short	33	8.2	3.3
	L2 (nH)	39	18	2.7	1.8
	C3 (pF)	220	47	47	47
	C4 (pF)	220	47	47	47
	C5 (pF)	3300	220	100	220
	C6 (pF)	6.8	1	1.5	Open
	C7 (pF)	220	47	47	47

Evaluates: MAX2660/MAX2661/MAX2663/MAX2671

MAX2660/MAX2661/MAX2663/MAX2671 Evaluation Kits

Evaluates: MAX2660/MAX2661/MAX2663/MAX2671

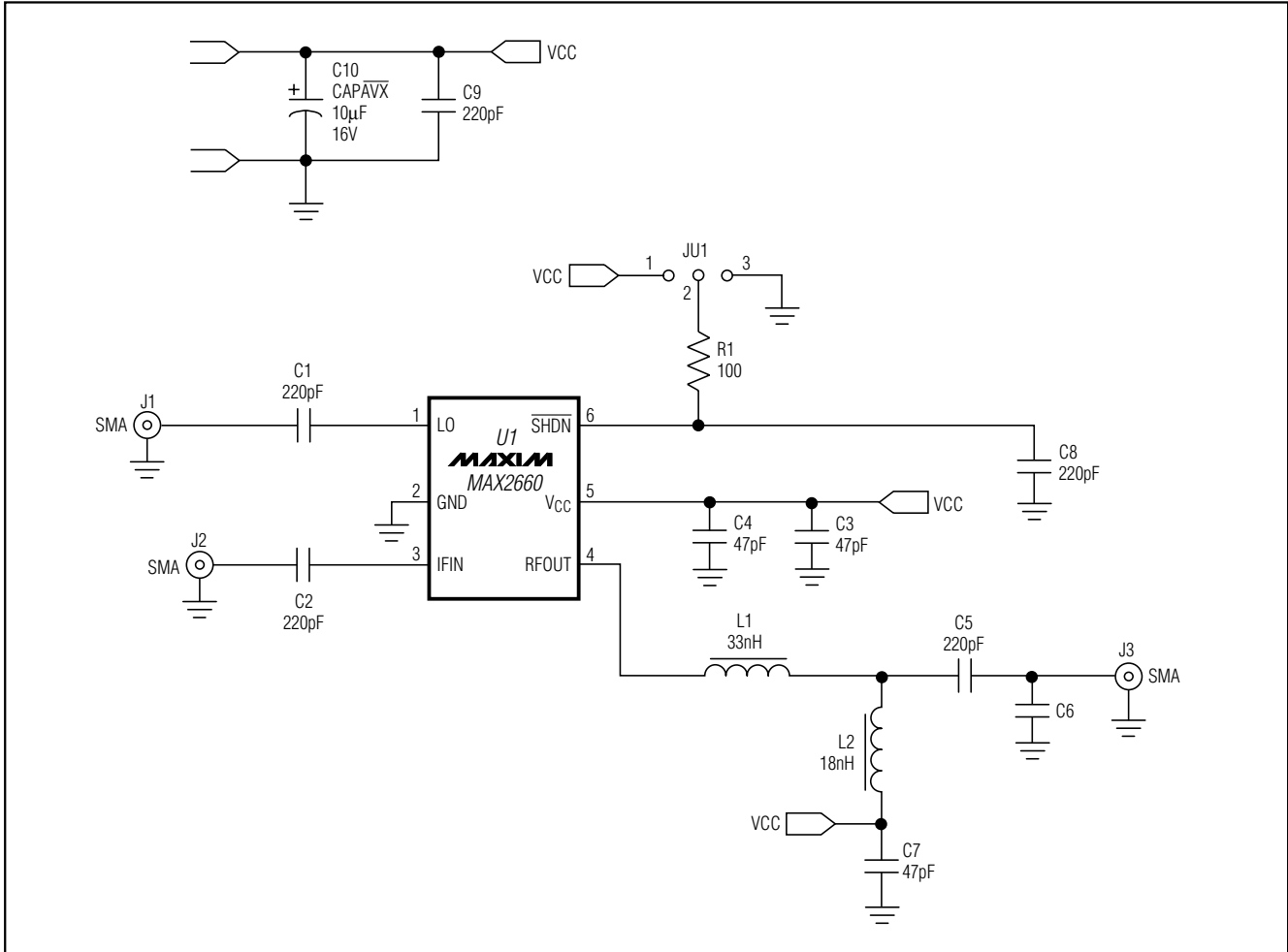

Figure 1. MAX2660 EV Kit Schematic

MAX2660 Evaluation Kit

Evaluates: MAX2660/MAX2661/MAX2663/MAX2671

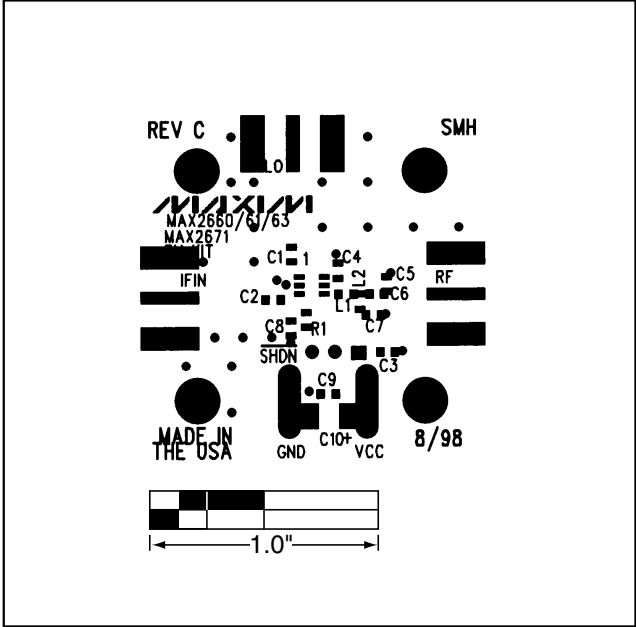

Figure 2. MAX2660 EV Kit PC Board Layout—Component Side

MAX2660/MAX2661/MAX2663/MAX2671 Evaluation Kits

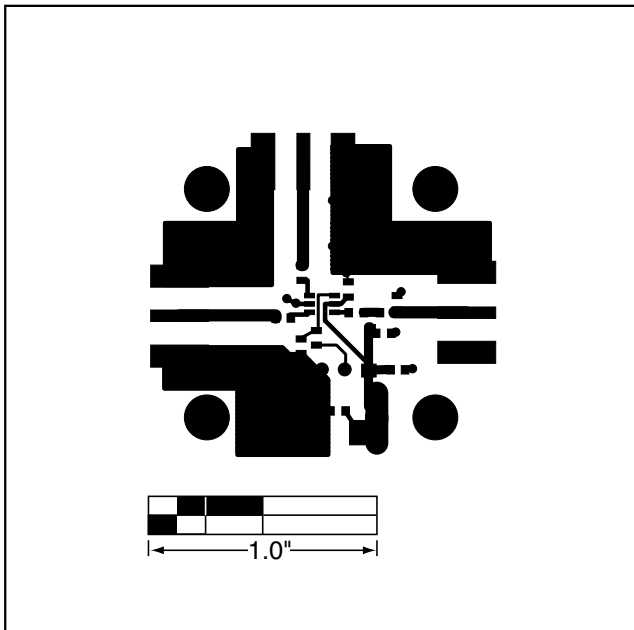

Figure 3. MAX2660 EV Kit PC Board Layout—Component Side Metal

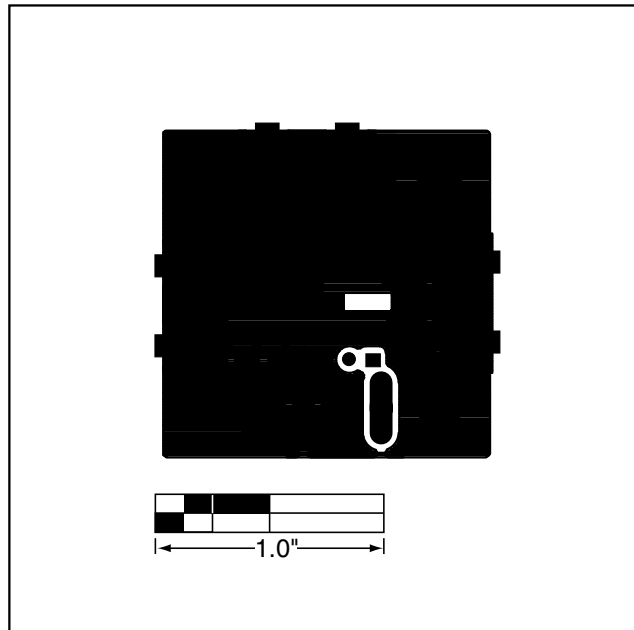

Figure 4. MAX2660 EV Kit PC Board Layout—Solder Side Metal



Стандарт Электрон Связь

Мы молодая и активно развивающаяся компания в области поставок электронных компонентов. Мы поставляем электронные компоненты отечественного и импортного производства напрямую от производителей и с крупнейших складов мира.

Благодаря сотрудничеству с мировыми поставщиками мы осуществляем комплексные и плановые поставки широчайшего спектра электронных компонентов.

Собственная эффективная логистика и склад в обеспечивает надежную поставку продукции в точно указанные сроки по всей России.

Мы осуществляем техническую поддержку нашим клиентам и предпродажную проверку качества продукции. На все поставляемые продукты мы предоставляем гарантию .

Осуществляем поставки продукции под контролем ВП МО РФ на предприятия военно-промышленного комплекса России , а также работаем в рамках 275 ФЗ с открытием отдельных счетов в уполномоченном банке. Система менеджмента качества компании соответствует требованиям ГОСТ ISO 9001.

Минимальные сроки поставки, гибкие цены, неограниченный ассортимент и индивидуальный подход к клиентам являются основой для выстраивания долгосрочного и эффективного сотрудничества с предприятиями радиоэлектронной промышленности, предприятиями ВПК и научно-исследовательскими институтами России.

С нами вы становитесь еще успешнее!

Наши контакты:

Телефон: +7 812 627 14 35

Электронная почта: sales@st-electron.ru

Адрес: 198099, Санкт-Петербург,
Промышленная ул, дом № 19, литера Н,
помещение 100-Н Офис 331