



# TWR-K20D72M

---

## User Manual

Rev. 1.1

## Contents

<b>1 TWR-K20D72M Overview .....</b>	<b>4</b>
1.1 Features .....	4
1.2 Getting started .....	5
1.3 Reference Documents .....	5
<b>2 Hardware Description .....</b>	<b>5</b>
2.1 K20D72M Microcontroller .....	6
2.2 Clocking .....	7
2.3 System Power .....	7
2.3.1 Board Power Select .....	7
2.3.2 RTC VBAT .....	7
2.4 Debug Interface .....	8
2.4.1 OSJTAG .....	8
2.4.2 Cortex Debug Connector .....	8
2.5 USB Interface .....	9
2.6 Infrared Port .....	9
2.7 External Bus Interface – FlexBus .....	9
2.8 Accelerometer .....	9
2.9 Potentiometer, Pushbuttons, LEDs .....	9
2.10 General Purpose Tower Plug-in (TWRPI) Socket .....	10
2.11 Touch Interface .....	10
2.12 Microphone and buzzer .....	11
<b>3 Jumper Table .....</b>	<b>12</b>
<b>4 Input/Output Connectors and Pin Usage Table .....</b>	<b>13</b>
<b>5 Elevator Connections .....</b>	<b>15</b>

## List of Figures

<b>Figure 1.</b> Front side of TWR-K20D72M module.....	4
<b>Figure 2.</b> Back side of TWR-K20D72M module.....	5
<b>Figure 3.</b> TWR-K20D72M Block Diagram .....	6
<b>Figure 4.</b> Infrared Port Implementation .....	9

## List of Tables

<b>Table 1.</b> Cortex Debug Connector Pinout.....	8
<b>Table 2.</b> TWRPI Socket Pin Description.....	10
<b>Table 3.</b> Touch TWRPI Pin Description .....	11
<b>Table 4.</b> TWR-K20D72M Jumper Table.....	12
<b>Table 5.</b> I/O Connectors and Pin Usage Table .....	13
<b>Table 6.</b> TWR-K20D72M Primary Connector Pinout.....	15

## Revision History

Revision	Date	Changes
0.1	March 15, 2011	Initial Release

# 1 TWR-K20D72M Overview

The K20D72M Tower MCU Module (TWR-K20D72M) is a low-cost evaluation, demonstration and development board, which features the Kinetis K20 72MHz low-power microcontroller. These devices are based on the ARM® Cortex™-M4 architecture with USB 2.0 full-speed OTG controller. The TWR-K20D72M microcontroller module can operate in stand-alone mode or as part of the Freescale Tower System, a modular development platform that enables rapid prototyping and tool re-use through reconfigurable hardware. Take your design to the next level and begin constructing your Tower System today by visiting [www.freescale.com/tower](http://www.freescale.com/tower) for additional Tower System microcontroller modules and compatible peripherals.

## 1.1 Features

The following list summarizes the features of the K20D72M Tower MCU boards:

- Tower compatible processor board
- S08JM60 based Open Source BDM (OSBDM) circuit
- Four (4) user-controlled status LEDs
- Two (2) Capacitive Touch Pads and two (2) mechanical push buttons
- Socket for Capacitive Touch Pad daughter board (Touch TWRPI)
- Socket for Tower Plug-in (TWRPI, e.g. sensor board)
- Standalone USB host and device function
- Microphone and buzzer
- Potentiometer
- MMA8451Q three-axis accelerometer
- Battery holder for 20mm lithium battery (e.g. 2032, 2025)
- Board power select with 3.3V or 1.8V MCU operation



Figure 1. Front side of TWR-K20D72M module



Figure 2. Back side of TWR-K20D72M module

## 1.2 Getting started

Follow the Quick Start Guide found printed in the TWR-K20D72M box or the interactive DVD for the list of recommended steps for getting started. There are also lab walk-through guides available on the tool support page for the TWR-K20D72M: <http://www.freescale.com/TWR-K20D72M>.

## 1.3 Reference Documents

The documents listed below should be referenced for more information on the Kinetis family, Tower System and the MCU modules. These can be found in the documentation section of <http://www.freescale.com/TWR-K20D72M> or <http://www.freescale.com/kinetis>.

- [TWR-K20D72M Quick Start Guide](#)
- [TWR-K20D72M Schematics](#)
- [K20 Family Product Brief](#)
- [K20 Family Reference Manual](#)
- [Kinetis Quick Reference User Guide \(KQRUG\)](#)

## 2 Hardware Description

The TWR-K20D72M is a Tower System module featuring the MK20DX256VLL7 – an ARM<sup>®</sup> Cortex-M4<sup>™</sup> based microcontroller with USB 2.0 full-speed OTG controllers in a 100LQFP package with a maximum core operating frequency of 72MHz. It is intended for use in the Freescale Tower System but can operate stand-alone. An on-board debug circuit, OSJTAG, provides a JTAG debug interface and a power supply input through a single USB mini-AB connector. Figure 3 shows a block diagram for the TWR-K20D72M. The following sections describe the hardware in more detail.

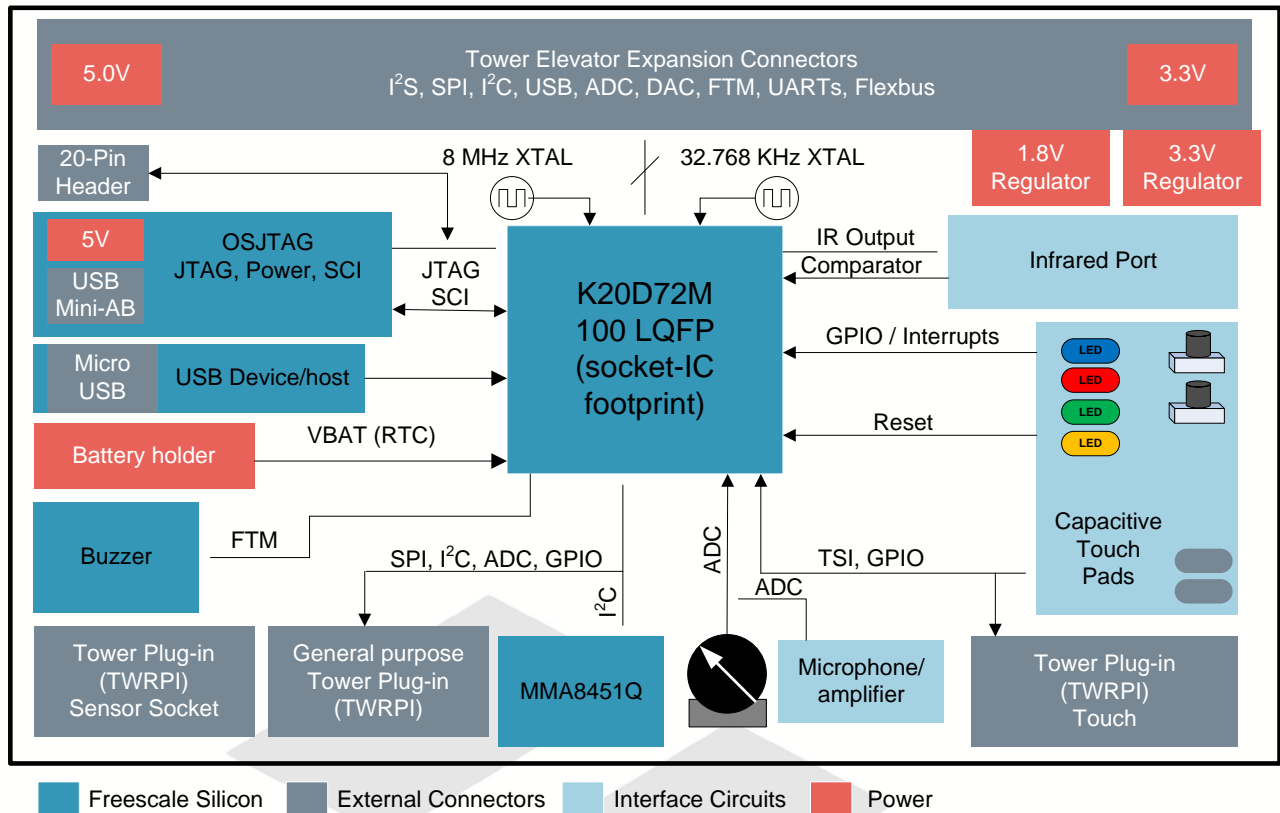

Figure 3: TWR-K20D72M Block Diagram

## 2.1 K20D72M Microcontroller

The TWR-K20D72M module features the MK20DX256VLL7. The Kinetis K20 microcontroller family is part of the Kinetis portfolio of devices built around an ARM® Cortex-M4™ core. Refer to the [K20 Family Product Brief](#) and the [K20 Family Reference Manual](#) for comprehensive information on the MK20DX256VLL7 device. MK20DX256VLL7 key features:

- 32-bit ARM Cortex-M4 core with DSP instructions
- 72MHz maximum core operating frequency
- 100LQFP, 14mm x 14mm, 0.5mm pitch package
- 1.71V – 3.6V operating voltage input range
- 256 Kbytes of program flash, 64 Kbytes of static RAM
- External bus interface
- Power management controller with 10 different power modes
- Multi-purpose clock generator with PLL and FLL operation modes
- 16-bit SAR ADC, 12-bit DAC
- High-speed analog comparator with 6-bit DAC

- Programmable voltage reference
- USB full-speed/low-speed OTG/Host/Device controller with device charge detect
- SPI, I<sup>2</sup>C (w/ SMBUS support), UART (w/ ISO7816 and IrDA), CAN, I<sup>2</sup>S
- GPIO with pin interrupt support, DMA request capability, digital glitch filtering
- Capacitive touch sensing inputs (TSI)
- Debug interfaces: JTAG, cJTAG, SWD
- Trace: TPIO, FPB, DWT, ITM

## 2.2 Clocking

The Kinetis MCUs start up from an internal digitally controlled oscillator (DCO). Software can enable one or two external oscillators if desired. The external oscillator for the multipurpose clock generator (MCG) module can range from 32.768 KHz up to a 32 MHz crystal or ceramic resonator. The external oscillator for the real time clock (RTC) module accepts a 32.768 kHz crystal.

Two crystals are provided on board for clocking the K20D72M device: 8 MHz crystal as main oscillator to clock MCG module and 32.768 kHz crystal for clocking RTC module.

## 2.3 System Power

In standalone operation, the main power source for the TWR-K20D72M is derived from the 5.0V input from either the USB mini-B connector, J14 or the debugger header, J11, when a shunt is placed on jumper J10. On board low-dropout regulator provides either 3.3V or 1.8V supply from the 5.0V input voltage based on jumper settings on J17, refer to sheet 5 of the TWR-K20D72M schematic for details.

When installed into a Tower System, the TWR-K20D72M can be powered from either an on-board source or from another source in the assembled Tower System. If both the on-board and off-board sources are available, the TWR-K20D72M will default to the off-board source.

The 3.3V or 1.8V power supplied to the MCU is routed through a jumper, J6. The jumper shunt can be removed to allow for either 1) alternate MCU supply voltages to be injected or 2) the measurement of power consumed by the MCU.

### 2.3.1 Board Power Select

TWR-K20D72M board include on board regulators for both 3.3V and 1.8V output and add jumper J17 to select which one to use as board power and CPU power. This allows MCU operation under 1.8V power supply.

### 2.3.2 RTC VBAT

The real time clock (RTC) module on the K20D72M has two modes of operation, system power-up and system power-down. During system power-down, the RTC is powered from the backup power supply, VBAT. The TWR-K20D72M provides a battery holder for a coin cell battery that can be used as the

VBAT supply. The holder can accept common 20mm diameter 3V lithium coin cell batteries (e.g. 2032, 2025). Refer to the description J13 in Table 4 “TWR-K20D72M Jumper Table” for more information.

## 2.4 Debug Interface

There are two debug interface options provided: the on-board OSJTAG circuit and an external Cortex Debug connector.

### 2.4.1 OSJTAG

An on-board, MC9S08JM60 based Open Source BDM (OSBDM) circuit provides a debug interface to the K20D72M. A standard USB A male to Mini-B male cable (provided) can be used for debugging via the USB connector, J14. The OSJTAG interface also provides a USB to serial bridge. Drivers for the OSJTAG interface are provided in the *P&E Micro Kinetis Tower Toolkit* (available on the included DVD).

### 2.4.2 Cortex Debug Connector

The Cortex Debug connector is a 20-pin (0.05") connector providing access to the SWD, SWV, JTAG, cJTAG, EzPort signals available on the K20 device. The pinout and K20 pin connections to the debug connector, J11, is shown in Table 1.

**Table 1.** Cortex Debug Connector Pinout

Pin	Function	TWR-K20D72M connection
1	VTref	MCU supply (MCU_PWR)
2	TMS/SWDIO	PTA3/UART0_RTS_b/FTM0_CH0/JTAG_MS/SWD_DIO
3	GND	GND
4	TCK/SWCLK	PTA0/UART0_CTS_b/FTM0_CH5/JTAG_CLK/SWD_CLK/EZP_CLK
5	GND	GND
6	TDO/SWO	PTA2/UART0_TX/FTM0_CH7/JTAG_DO/TRACE_SWO/EZP_DO
7	Key	-
8	TDI	PTA1/UART0_TX/FTM0_CH6/JTAG_DI/EZP_DI
9	GNDDetect	PTA4/FTM0_CH1/MS/NMI_b/EZP_CS_b
10	nReset	RESET_b
11	Target Power	5V supply (via J10)
12	-	-
13	Target Power	5V supply (via J10)
14	-	-
15	GND	GND
16	-	-
17	GND	GND
18	-	-
19	GND	GND
20	-	-



**Note:** there are no ETM signals on K20D72M, so the associated signals on Cortex Debugger connector is left empty.

## 2.5 USB Interface

TWR-K20D72M board allows using USB as host or device in standalone mode or with connection to TWR-SER board in a complete tower kit. Jumper J16 can be used to select which USB VBUS signal from USB connector to connect with the MCU VREGIN input pin. When using in standalone mode, short 5-6 on J16 and connect USB with on board Micro-USB connector J19, when using with TWR-SER board in complete tower kit, short 6-8 on J16 and connect USB with Mini-AB connector J14 on TWR-SER board. Refer to description on J16 in Table 4 “TWR-K20D72M Jumper Table” for more information.

## 2.6 Infrared Port

An infrared transmit and receive interface is implemented as shown in Figure 4 below. The CMT\_IRO pin directly drives an infrared diode. The receiver uses an infrared phototransistor connected to an on-chip analog comparator through a low-pass filter.

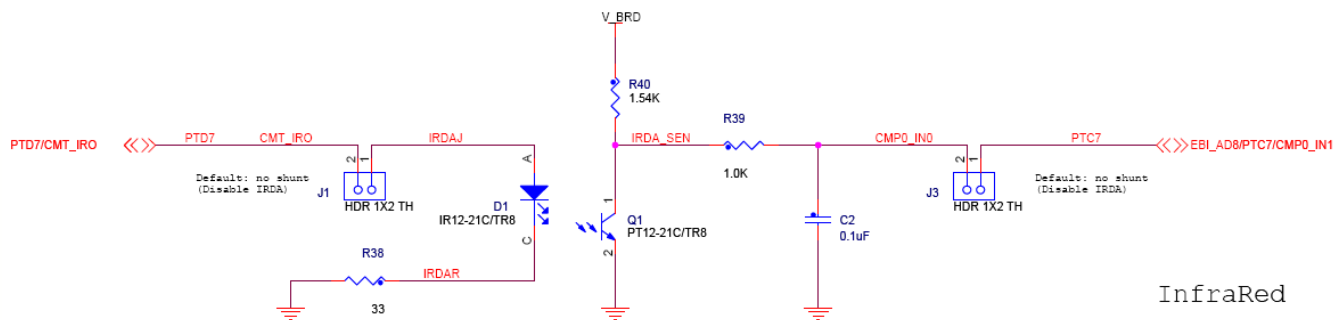

Figure 4: Infrared Port Implementation

## 2.7 External Bus Interface – FlexBus

The K20 device features a multi-function external bus interface called the FlexBus interface controller, capable of interfacing to slave-only devices. The FlexBus interface is not used directly on the TWR-K20D72M. Instead, a subset of the FlexBus is connected to the Primary Connector so that the external bus can access devices on Tower peripheral modules. Refer to Table 6 “TWR-K20D72M Primary Connector Pinout” and sheet 8 of the [TWR-K20D72M schematics](#) for more details.

## 2.8 Accelerometer

An MMA8451Q digital accelerometer is connected to the K20 MCU through an I2C interface and a GPIO/IRQ signal. Refer to Table 5 “I/O Connectors and Pin Usage Table” for connection details.

## 2.9 Potentiometer, Pushbuttons, LEDs

The TWR-K20D72M features two pushbutton switches connected to GPIO/interrupt signals, one pushbutton connected to the master reset signal, two capacitive touch pad electrodes, four user-

controllable LEDs, and a potentiometer connected to an ADC input signal. Refer to Table 5 “I/O Connectors and Pin Usage Table” for information about which port pins is connected to these features.

## 2.10 General Purpose Tower Plug-in (TWRPI) Socket

The TWR-K20D72M features a socket that can accept a variety of different Tower Plug-in modules featuring sensors, RF transceivers, and more. The General Purpose TWRPI socket provides access to I2C, SPI, IRQs, GPIOs, timers, analog conversion signals, TWRPI ID signals, reset, and voltage supplies. The pinout for the TWRPI Socket is defined in Table 2.

**Table 2.** TWRPI Socket Pin Description

Left-side 2x10 Connector		Right-side 2x10 Connector	
Pin	Description	Pin	Description
1	5V VCC	1	GND
2	3.3 V VCC	2	GND
3	GND	3	I2C: SCL
4	3.3V VDDA	4	I2C: SDA
5	VSS (Analog GND)	5	GND
6	VSS (Analog GND)	6	GND
7	VSS (Analog GND)	7	GND
8	ADC: Analog 0	8	GND
9	ADC: Analog 1	9	SPI: MISO
10	VSS (Analog GND)	10	SPI: MOSI
11	VSS (Analog GND)	11	SPI: SS
12	ADC: Analog 2	12	SPI: CLK
13	VSS (Analog GND)	13	GND
14	VSS (Analog GND)	14	GND
15	GND	15	GPIO: GPIO0/IRQ
16	GND	16	GPIO: GPIO1/IRQ
17	ADC: TWRPI ID 0	17	GPIO: GPIO2/UART0_RX
18	ADC: TWRPI ID 1	18	GPIO: GPIO3/ UART0_TX
19	GND	19	GPIO: GPIO4/ UART0_CTS
20	Reset	20	GPIO: GPIO5/ UART0_RTS

## 2.11 Touch Interface

The touch sensing input (TSI) module of the Kinetis MCUs provides capacitive touch sensing detection with high sensitivity and enhanced robustness. Each TSI pin implements the capacitive measurement of an electrode.

The TWR-K20D72M provides two methods for evaluating the TSI module. There are two individual electrodes on-board the TWR-K20D72M that simulates pushbuttons. Additionally, twelve TSI signals

are connected to a Touch Tower Plug-in (TWRPI) socket that can accept Touch TWRPI daughter cards that may feature keypads, rotary dials, sliders, etc.

The pinout for the Touch TWRPI socket is defined in Table 3. Refer to Table 5 “I/O Connectors and Pin Usage Table” for the specific K20 pin connections to the Touch TWRPI socket.

**Table 3.** Touch TWRPI Pin Description

Pin	Description
1	5V VCC
2	3.3 V VCC
3	Electrode 0
4	3.3V VDDA
5	Electrode 1
6	VSS (Analog GND)
7	Electrode 2
8	Electrode 3
9	Electrode 4
10	Electrode 5
11	Electrode 6
12	Electrode 7
13	Electrode 8
14	Electrode 9
15	Electrode 10
16	Electrode 11
17	ADC: TWRPI ID 0
18	ADC: TWRPI ID 1
19	GND
20	Reset

## 2.12 Microphone and buzzer

TWR-K20D72M board includes a microphone U16 which connects with one ADC channel to allow audio recording, there is a low-pass filter implemented before microphone input goes to ADC channel. Jumper J4 can be used for connection with the ADC channel. There is also a buzzer connected with one PWM output channel on FTM module, jumper J21 is used for this connection.

## 3 Jumper Table

There are several jumpers provided for isolation, configuration, and feature selection. Refer to the following table for details. The default installed jumper settings are shown in **bold** with asterisks.

**Table 4.** TWR-K20D72M Jumper Table

Jumper	Option	Setting	Description
J1	Infrared Transmitter Connection	<b>*ON*</b>	Connect PTD7/CMT_IRO/UART0_TX to IR Transmitter (D1)
		OFF	Disconnect PTD7/CMT_IRO/UART0_TX to IR Transmitter (D1)
J2	Enable Micro USB Power	<b>*ON*</b>	Enable USB Power control IC U14
		OFF	Disable USB Power control IC U14
J3	Infrared Receiver Connection	<b>*ON*</b>	Connect IRDA output to EBI_AD8/PTC7/CMP0_IN1
		OFF	Disable IRDA output to EBI_AD8/PTC7/CMP0_IN1
J4	Microphone connection	<b>*ON*</b>	Connection Microphone to ADC1_DP0
		OFF	Disable Microphone to ADC1_DP0
J6	MCU Power selection	<b>*ON*</b>	Connect on board VBRD for MCU power supply
		OFF	Isolate MCU from power supply (allows for external supply or power measurements)
J10	JTAG Power Connection	ON	Connect on-board 5V supply to JTAG port (supports powering board from external JTAG probe)
		<b>*OFF*</b>	Disconnect on-board 5V supply from JTAG port
J13	VBAT Power Selection	<b>*1-2*</b>	Connect VBAT to on-board 3.3V supply
		2-3	Connect VBAT to the higher voltage between on-board 3.3V supply or coin-cell supply
J15	OSJTAG Mode Selection	ON	OSJTAG bootloader mode (OSJTAG firmware reprogramming)
		<b>*OFF*</b>	Debugger mode
J16	Power 5V and VREG IN Selection	<b>*1-2*</b>	5V Power from OSBDM USB powers LDO regulator
		<b>*5-6*</b>	VBUS signal on Micro-USB connector J19 connects to VREGIN to allow standalone USB operation
		6-8	VBUS signal from elevator connector connects to VREGIN to allow USB operation with complete tower kit
J17	Board power selection	1-2	Board power from VOUT_3V3
		<b>*3-5*</b>	Board power from 3.3V regulator
		5-7	Board power from 1.8V regulator
J18	3.3V VOUT Selection	ON	Connect USB 3.3V regulator output to MCU_PWR
		<b>*OFF*</b>	Disconnect USB 3.3V regulator output to MCU_PWR
J20	USB power IC over-current signal connection	<b>*ON*</b>	Connect over-current signal on USB power IC MIC-2026 to PTC8
		OFF	Disconnect over-current signal on USB power IC MIC-2026 to PTC8
J21	Enable Buzzer	<b>*ON*</b>	Enable buzzer to EBI_AD11/FTM0_CH3
		OFF	Disable buzzer to EBI_AD11/FTM0_CH3

J23	Enable IRQ2 to ACCELEROMETER	ON	Enable IRQ2 to ACCELEROMETER
		<b>*OFF*</b>	Disable IRQ2 to ACCELEROMETER
J24	Enable IRQ1 to ACCELEROMETER	ON	Enable IRQ1 to ACCELEROMETER
		<b>*OFF*</b>	Disable IRQ1 to ACCELEROMETER
J25	Enable SCL to ACCELEROMETER	<b>*ON*</b>	Enable SCL to ACCELEROMETER
		OFF	Disable SCL to ACCELEROMETER
J26	Enable SDA to ACCELEROMETER	<b>*ON*</b>	Enable SDA to ACCELEROMETER
		OFF	Disable SDA to ACCELEROMETER
J27	Enable POTENTIOMETER	<b>*ON*</b>	Enable POTENTIOMETER to ADC1_DM0
		OFF	Disable POTENTIOMETER to ADC1_DM0

## 4 Input/Output Connectors and Pin Usage Table

Table 5 provides details on which K20D72M pins are using to communicate with the TWR-K20D72M sensors, LEDs, switches, and other I/O interfaces.

**Note:** Some port pins are used in multiple interfaces on-board and many are potentially connected to off-board resources via the Primary and Secondary Connectors. Take care to avoid attempted simultaneous usage of mutually exclusive features.

**Table 5.** I/O Connectors and Pin Usage Table

Feature	Connection	Port Pin	Pin Function
Infrared Port	IR Transmit	PTD7	CMT_IRO
	IR Receive	PTC7	CMPO_IN1
Pushbuttons	SW1 (IRQ0)	PTC1	PTC1
	SW2 (IRQ1)	PTC2	PTC2
	SW3 (RESET)	RESET_b	RESET_b
Touch Pads	Touch	PTB0	TSIO_CH0
	Touch	PTB1	TSIO_CH6
LEDs	D2 / Orange LED	PTC4	RESET_b
	D3 / Yellow LED	3.3V	Power on
	D4 / YEL/GRN LED	PTD1	OSBDM status
	D5 / Yellow LED	PTD0	OSBDM target power
	D7/Green LED	PTC7	Green LED
	D8/Blue LED	PTC8	Blue LED
	D9	PTC9	D9 Electrode LED
	D10	PTC10	D10 Electrode LED
Potentiometer	Potentiometer (R42)	-	ADC1_DM0
Microphone	Microphone	-	ADC1_DP0
BUZZER	BUZZER	PTC4	FTM0_CH3

Accelerometer	I2C SDA	PTB3	I2C0_SDA
	I2C SCL	PTB2	I2C0_SCL
	IRQ1	PTB0	PTB0
	IRQ2	PTB1	PTB1
General Purpose TWRPI Socket	TWRPI AN0 (J7 Pin 8)	PTB0	ADC0_SE8
	TWRPI AN1 (J7 Pin 9)	PTB1	ADC0_SE9
	TWRPI AN2 (J7 Pin 12)	—	ADC1_DP0
	TWRPI ID0 (J7 Pin 17)	—	ADC0_DP0
	TWRPI ID1 (J7 Pin 18)	—	ADC0_DM0
	TWRPI I2C SCL (J8 Pin 3)	PTB2	I2C0_SCL
	TWRPI I2C SDA (J8 Pin 4)	PTB3	I2C0_SDA
	TWRPI SPI MISO (J8 Pin 9)	PTD3	SPI0_SIN
	TWRPI SPI MOSI (J8 Pin 10)	PTD2	SPI0_SOUT
	TWRPI SPI SS (J8 Pin 11)	PTD4	SPI0_PCS1
	TWRPI SPI CLK (J8 Pin 12)	PTD1	SPI0_SCK
	TWRPI GPIO0 (J8 Pin 15)	PTC5	PTC5
	TWRPI GPIO1 (J8 Pin 16)	PTC6	PTC6
	TWRPI GPIO2 (J8 Pin 17)	PTD6	UART0_RX
	TWRPI GPIO3 (J8 Pin 18)	PTD7	UART0_TX
TWRPI GPIO4 (J8 Pin 19)	PTD5	UART0_CTS	
TWRPI GPIO5 (J8 Pin 20)	PTD4	UART0_RTS	
Touch Pad TWRPI Socket	Electrode 0 (J5 Pin 3)	PTB0	TSIO_CH0
	Electrode 1 (J5 Pin 5)	PTB1	TSIO_CH6
	Electrode 2 (J5 Pin 7)	PTB2	TSIO_CH7
	Electrode 3 (J5 Pin 8)	PTB3	TSIO_CH8
	Electrode 4 (J5 Pin 9)	PTC0	TSIO_CH13
	Electrode 5 (J5 Pin 10)	PTC1	TSIO_CH14
	Electrode 6 (J5 Pin 11)	PTC2	TSIO_CH15
	Electrode 7 (J5 Pin 12)	PTA4	TSIO_CH5
	Electrode 8 (J5 Pin 13)	PTB16	TSIO_CH9
	Electrode 9 (J5 Pin 14)	PTB17	TSIO_CH10
	Electrode 10 (J5 Pin 15)	PTB18	TSIO_CH11
	Electrode 11 (J5 Pin 16)	PTB19	TSIO_CH12
	TWRPI ID0 (J5 Pin 17)	—	ADC0_DP0
	TWRPI ID1 (J5 Pin 18)	—	ADC0_DM0

## 5 Elevator Connections

The TWR-K20D72M features two expansion card-edge connectors that interface to Elevator boards in a Tower System: the Primary and Secondary Elevator connectors. The Primary Elevator connector, comprised of sides A and B, is utilized by the TWR-K20D72M, while the Secondary Elevator connector only makes connections to ground (GND). Table 6 provides the pinout for the Primary Elevator Connector.

**Table 6.** TWR-K20D72M Primary Connector Pinout

Pin #	Side B		Pin #	Side A	
	Name	Usage		Name	Usage
B1	<b>5V</b>	<b>5.0V Power</b>	A1	<b>5V</b>	<b>5.0V Power</b>
B2	<b>GND</b>	<b>Ground</b>	A2	<b>GND</b>	<b>Ground</b>
B3	<b>3.3V</b>	<b>3.3V Power</b>	A3	<b>3.3V</b>	<b>3.3V Power</b>
B4	ELE_PS_SENSE	Elevator Power Sense	A4	<b>3.3V</b>	<b>3.3V Power</b>
B5	<b>GND</b>	<b>Ground</b>	A5	<b>GND</b>	<b>Ground</b>
B6	<b>GND</b>	<b>Ground</b>	A6	<b>GND</b>	<b>Ground</b>
B7	SDHC_CLK / SPI1_CLK	PTE2	A7	SCL0	PTB2
B8	SDHC_D3 / SPI1_CS1_b		A8	SDA0	PTB3
B9	SDHC_D3 / SPI1_CS0_b	PTE4	A9	GPIO9 / CTS1	PTC9
B10	SDHC_CMD / SPI1_MOSI	PTE1	A10	GPIO8 / SDHC_D2	PTB22
B11	SDHC_D0 / SPI1_MISO	PTE3	A11	GPIO7 / SD_WP_DET	PTB21
B12	ETH_COL		A12	ETH_CRS	
B13	ETH_RXER		A13	ETH_MDC	
B14	ETH_TXCLK		A14	ETH_MDIO	
B15	ETH_TXEN		A15	ETH_RXCLK	
B16	ETH_TXER		A16	ETH_RXDV	
B17	ETH_TXD3		A17	ETH_RXD3	
B18	ETH_TXD2		A18	ETH_RXD2	
B19	ETH_TXD1		A19	ETH_RXD1	
B20	ETH_TXD0		A20	ETH_RXD0	
B21	GPIO1 / RTS1	PTC7	A21	SSI_MCLK	PTC8
B22	GPIO2 / SDHC_D1	PTE0	A22	SSI_BCLK	PTB18
B23	GPIO3	PTB20	A23	SSI_FS	PTB19
B24	CLKIN0		A24	SSI_RXD	PTC11
B25	CLKOUT1	PTE26	A25	SSI_TXD	PTC0
B26	<b>GND</b>	<b>Ground</b>	A26	<b>GND</b>	<b>Ground</b>
B27	AN7	PTB0	A27	AN3	ADC0_DP0
B28	AN6	PTB1	A28	AN2	ADC0_DM0
B29	AN5	PTB2	A29	AN1	ADC1_DP0
B30	AN4	PTB3	A30	AN0	ADC1_DM0
B31	<b>GND</b>	<b>Ground</b>	A31	<b>GND</b>	<b>Ground</b>
B32	DAC1		A32	DAC0	DAC0_OUT
B33	TMR3		A33	TMR1	PTA13
B34	TMR2	PTD7	A34	TMR0	PTA12
B35	GPIO4	PTA14	A35	GPIO6	PTA15
B36	<b>3.3V</b>	<b>3.3V Power</b>	A36	<b>3.3V</b>	<b>3.3V Power</b>
B37	PWM7		A37	PWM3	PTC4
B38	PWM6	PTD6	A38	PWM2	PTC3
B39	PWM5	PTD5	A39	PWM1	PTC2
B40	PWM4	PTD4	A40	PWM0	PTC1
B41	CANRX0	PTA13	A41	RXD0	PTD6

Pin #	Side B		Pin #	Side A	
	Name	Usage		Name	Usage
B42	CANTX0	PTA12	A42	TXD0	PTD7
B43	1WIRE		A43	RXD1	PTE1
B44	SPI0_MISO	PTD3	A44	TXD1	PTE0
B45	SPI0_MOSI	PTD2	A45	VSS	VSSA
B46	SPI0_CS0_b	PTD0	A46	VDDA	VDDA
B47	SPI0_CS1_b	PTD4	A47	VREFA1	
B48	SPI0_CLK	PTD1	A48	VREFA2	
B49	<b>GND</b>	<b>Ground</b>	A49	<b>GND</b>	Ground
B50	SCL1	PTB2	A50	GPIO14	PTC12
B51	SDA1	PTB3	A51	GPIO15	PTC13
B52	GPIO5 / SPI0_HOLD/IO3	PTC10	A52	GPIO16	PTC14
B53	USB0_DP_PDOWN		A53	GPIO17	PTC15
B54	USB0_DM_PDOWN		A54	USB0_DM	USB0_DN
B55	IRQ_H	PTE25	A55	USB0_DP	USB0_DP
B56	IRQ_G	PTE24	A56	USB0_ID	
B57	IRQ_F	PTE6	A57	USB0_VBUS	USB0_VBUS
B58	IRQ_E	PTE5	A58	TMR7	
B59	IRQ_D	PTA17	A59	TMR6	
B60	IRQ_C	PTA16	A60	TMR5	
B61	IRQ_B	PTC6	A61	TMR4	
B62	IRQ_A	PTC5	A62	RSTIN_b	RESET_b
B63	EBI_ALE / EBI_CS1_b	PTD0	A63	RSTOUT_b	PTE1
B64	EBI_CS0_b	PTD1	A64	CLKOUT0	PTC3
B65	<b>GND</b>	<b>Ground</b>	A65	<b>GND</b>	<b>Ground</b>
B66	EBI_AD15	PTB18	A66	EBI_AD14	PTC0
B67	EBI_AD16	PTB17	A67	EBI_AD13	PTC1
B68	EBI_AD17	PTB16	A68	EBI_AD12	PTC2
B69	EBI_AD18	PTB11	A69	EBI_AD11	PTC4
B70	EBI_AD19	PTB10	A70	EBI_AD10	PTC5
B71	EBI_R/W_b	PTC11	A71	EBI_AD9	PTC6
B72	EBI_OE_b	PTB19	A72	EBI_AD8	PTC7
B73	EBI_D7	PTC8	A73	EBI_AD7	LATCH_AD7
B74	EBI_D6	PTC9	A74	EBI_AD6	LATCH_AD6
B75	EBI_D5	PTC10	A75	EBI_AD5	LATCH_AD5
B76	EBI_D4	PTD2	A76	EBI_AD4	LATCH_AD4
B77	EBI_D3	PTD3	A77	EBI_AD3	LATCH_AD3
B78	EBI_D2	PTD4	A78	EBI_AD2	LATCH_AD2
B79	EBI_D1	PTD5	A79	EBI_AD1	LATCH_AD1
B80	EBI_D0	PTD6	A80	EBI_ADO	LATCH_ADO
B81	<b>GND</b>	<b>Ground</b>	A81	<b>GND</b>	<b>Ground</b>
B82	<b>3.3V</b>	<b>3.3V Power</b>	A82	<b>3.3V</b>	<b>3.3V Power</b>





Freescale<sup>™</sup> and the Freescale logo are trademarks of Freescale Semiconductor, Inc. All other product or service names are the property of their respective owners.

© Freescale Semiconductor, Inc. 2011. All rights reserved.



## Стандарт Электрон Связь

Мы молодая и активно развивающаяся компания в области поставок электронных компонентов. Мы поставляем электронные компоненты отечественного и импортного производства напрямую от производителей и с крупнейших складов мира.

Благодаря сотрудничеству с мировыми поставщиками мы осуществляем комплексные и плановые поставки широчайшего спектра электронных компонентов.

Собственная эффективная логистика и склад в обеспечивает надежную поставку продукции в точно указанные сроки по всей России.

Мы осуществляем техническую поддержку нашим клиентам и предпродажную проверку качества продукции. На все поставляемые продукты мы предоставляем гарантию .

Осуществляем поставки продукции под контролем ВП МО РФ на предприятия военно-промышленного комплекса России , а также работаем в рамках 275 ФЗ с открытием отдельных счетов в уполномоченном банке. Система менеджмента качества компании соответствует требованиям ГОСТ ISO 9001.

Минимальные сроки поставки, гибкие цены, неограниченный ассортимент и индивидуальный подход к клиентам являются основой для выстраивания долгосрочного и эффективного сотрудничества с предприятиями радиоэлектронной промышленности, предприятиями ВПК и научно-исследовательскими институтами России.

С нами вы становитесь еще успешнее!

### Наши контакты:

**Телефон:** +7 812 627 14 35

**Электронная почта:** [sales@st-electron.ru](mailto:sales@st-electron.ru)

**Адрес:** 198099, Санкт-Петербург,  
Промышленная ул, дом № 19, литера Н,  
помещение 100-Н Офис 331