



# High-Voltage Liquid Lens Driver

MAX14515

## General Description

The MAX14515 high-voltage liquid lens driver features a high-voltage differential output controlled through an I<sup>2</sup>C interface. The MAX14515 uses a charge-pump-based boost converter and integrated H-bridge to provide a compact lens driver solution with minimal external components to achieve a small overall footprint suitable for small space constraints inside camera modules.

The MAX14515 features an 8-bit monotonic DAC with a single differential high-voltage output controlled by a 2-wire I<sup>2</sup>C interface to set the amplitude. The high-voltage outputs are capable of delivering up to 42V<sub>RMS</sub> (min) into a 220pF liquid lens load at 1.0kHz (min).

The MAX14515 also features two power-saving modes (shutdown mode and sleep mode) to minimize power consumption when the device is inactive. Shutdown mode places the device in a low-power state that resets all registers and disables the I<sup>2</sup>C interface to reduce current below 500nA (max). In sleep mode, the power-on reset circuit remains active. If no activity is detected on the I<sup>2</sup>C interface, current consumption is less than 3μA.

The MAX14515 operates over the +2.7V to +5.5V supply voltage range, ideal for portable applications using lithium ion battery sources. The MAX14515 is specified over the -40°C to +85°C extended temperature range and is available in a small (1mm x 2mm) 8-bump WLP package.

## Applications

Autofocus Camera Modules  
Barcode Readers  
Webcams

## Pin Configuration

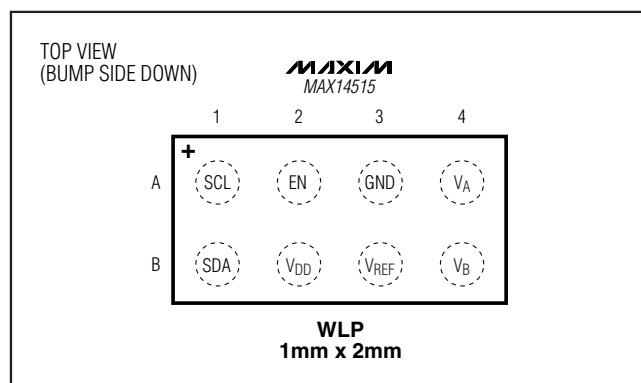

## Features

- ◆ Small Footprint for Placement Inside Camera Modules
- ◆ 47V<sub>RMS</sub> Maximum Output (C<sub>LENS</sub> = 220pF)
- ◆ I<sup>2</sup>C-Compatible Interface for Setting Output Voltage
- ◆ 8-Bit Output Voltage Resolution
- ◆ Guaranteed Monotonic Output
- ◆ ±15kV Human Body Model ESD Protection on Outputs
- ◆ Low 500nA (max) Shutdown Current
- ◆ +2.7V to +5.5V Input Voltage Range
- ◆ Space-Saving, 8-Bump WLP (1mm x 2mm) Package

## Ordering Information

PART	TEMP RANGE	PIN-PACKAGE	TOP MARK
MAX14515EWA+	-40°C to +85°C	8 WLP	+AAA

+Denotes a lead-free/RoHS-compliant package.

## Typical Application Circuit

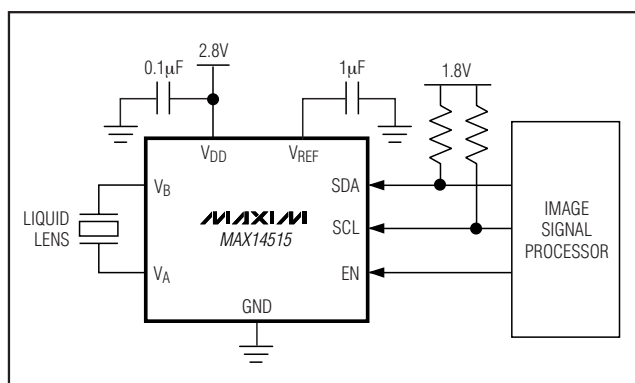

# High-Voltage Liquid Lens Driver

## ABSOLUTE MAXIMUM RATINGS

(All voltages referenced to GND.)

V <sub>DD</sub> .....	-0.3V to +6.0V
V <sub>A</sub> , V <sub>B</sub> .....	-0.3V to +52V
V <sub>REF</sub> .....	MAX (-0.3V, V <sub>DD</sub> - 0.3V) to +6.0V
SDA, SCL, EN.....	-0.3V to +6.0V
Continuous Power Dissipation (T <sub>A</sub> = +70°C):	
8-Bump WLP (derate 5.2mW/°C above +70°C).....	416mW

Junction-to-Ambient Thermal Resistance (q<sub>JA</sub>) (Note 1)

8-Bump WLP.....	192°C/W
Operating Temperature Range.....	-40°C to +85°C
Junction Temperature.....	+150°C
Storage Temperature Range.....	-65°C to +150°C
Lead Temperature (soldering, 10s).....	+300°C

**Note 1:** Package thermal resistances were obtained using the method described in JEDEC specification JESD51-7, using a four-layer board. For detailed information on package thermal considerations, refer to [www.maxim-ic.com/thermal-tutorial](http://www.maxim-ic.com/thermal-tutorial).

Stresses beyond those listed under "Absolute Maximum Ratings" may cause permanent damage to the device. These are stress ratings only, and functional operation of the device at these or any other conditions beyond those indicated in the operational sections of the specifications is not implied. Exposure to absolute maximum rating conditions for extended periods may affect device reliability.

## ELECTRICAL CHARACTERISTICS

(V<sub>DD</sub> = +2.7V to +5.5V, C<sub>VDD</sub> = 0.1μF, C<sub>REF</sub> = 1μF, C<sub>LENS</sub> = 220pF, T<sub>A</sub> = -40°C to +85°C, unless otherwise noted. Typical values are at V<sub>DD</sub> = +2.8V and T<sub>A</sub> = +25°C.) (Note 2)

PARAMETER	SYMBOL	CONDITIONS	MIN	TYP	MAX	UNITS
Input Voltage	V <sub>DD</sub>		2.7		5.5	V
Input Supply Current	I <sub>DD</sub>	Peak output voltage register (VP) = 0xFF		9		mA
Reference Output Voltage	V <sub>REF</sub>				5.5	V
Shutdown Supply Current	I <sub>SHDN</sub>	EN = GND		1	500	nA
Sleep Supply Current	I <sub>SLEEP</sub>	SM = 0, V <sub>EN</sub> = 1.8V, V <sub>DD</sub> = 4.2V		8		μA
		SDA = SCL, V <sub>EN</sub> = V <sub>DD</sub> , V <sub>DD</sub> = 2.8V		1.2	3	
POR Threshold	V <sub>TH_POR</sub>				2.6	V
<b>HIGH-VOLTAGE OUTPUTS (V<sub>A</sub>, V<sub>B</sub>)</b>						
Peak Output Voltage (Note 3)	V <sub>PEAK</sub>	VP = 0x01			10	V
		VP = 0xFF			52	
Output RMS Voltage	V <sub>RMS</sub>	VP = 0x01			10	V
		VP = 0xFF	42		47	
Output Voltage Ripple	V <sub>RPL</sub>	C <sub>LENS</sub> = 120pF		±250		mV
Pulldown Strength	R <sub>LPD</sub>	SM = 0			2	kΩ
Output Switching Frequency	f <sub>LENS</sub>		1	1.1	1.2	kHz
<b>CONTROL INPUTS (SDA, SCL, EN)</b>						
Input Logic-High Voltage	V <sub>IH</sub>		1.5			V
Input Logic-Low Voltage	V <sub>IL</sub>				0.5	V
Output Logic-Low Voltage	V <sub>OL</sub>	I <sub>SINK</sub> = 3mA			0.4	V
Input Low Leakage Current	I <sub>IL</sub>	EN = V <sub>CC</sub>		0.01	6	μA
		EN = GND		0.01	0.5	
Input High Leakage Current	I <sub>IH</sub>			0.01	2.5	μA
Input Capacitance	C <sub>IN</sub>			10		pF

# High-Voltage Liquid Lens Driver

MAX14515

## ELECTRICAL CHARACTERISTICS (continued)

( $V_{DD} = +2.7V$  to  $+5.5V$ ,  $C_{VDD} = 0.1\mu F$ ,  $C_{REF} = 1\mu F$ ,  $C_{LENS} = 220pF$ ,  $T_A = -40^\circ C$  to  $+85^\circ C$ , unless otherwise noted. Typical values are at  $V_{DD} = +2.8V$  and  $T_A = +25^\circ C$ .) (Note 2)

PARAMETER	SYMBOL	CONDITIONS	MIN	TYP	MAX	UNITS
<b>OUTPUT-VOLTAGE STATIC PERFORMANCE (<math>V_A</math>, <math>V_B</math>)</b>						
Resolution	N			8		Bits
Least Significant Bit	LSB	(Note 4)		157.5		mV
Integral Nonlinearity	INL		-4		+4	LSB
Differential Nonlinearity	DNL	(Note 5)	-1		+1	LSB
<b>OUTPUT VOLTAGE DYNAMIC PERFORMANCE (<math>V_A</math>, <math>V_B</math>)</b>						
Peak-Output Voltage Settling Time	$t_{sv}$	VP = any value to any other value transition; time to settle within 7 LSBs of final value, Figure 1			1	ms
Output Slew Rate	$SR_V$	Peak output voltage register = FFh			5	V/ $\mu s$
Wake-Up Time	$t_{WAKE}$	Time to settle within 7 LSBs of peak value, Figure 1			2	ms
Shutdown Time	$t_{SHDN}$	Figure 2			100	$\mu s$
<b>I<sup>2</sup>C INTERFACE</b>						
Serial-Clock Frequency	$f_{SCL}$				400	kHz
Bus Free Time Between START and STOP Condition	$t_{BUF}$		1.3			$\mu s$
Hold Time for Repeated START Condition	$t_{HD:STA}$		0.6			$\mu s$
Low Period for SCL Clock	$t_{LOW}$		1.3			$\mu s$
High Period for SCL Clock	$t_{HIGH}$		0.6			$\mu s$
Setup Time for Repeated START Condition	$t_{SU:STA}$		0.6			$\mu s$
Data Hold Time	$t_{HD:DAT}$		0		0.9	$\mu s$
Data Setup Time	$t_{SU:DAT}$		100			ns
Rise Time of Both SDA and SCL Signals	$t_r$				300	ns
Fall Time of Both SDA and SCL Signals	$t_f$				300	ns
Setup Time for STOP Condition	$t_{SU:STO}$		0.6			$\mu s$
Capacitive Load for Each Bus Line	$C_b$				400	pF
<b>ESD PROTECTION</b>						
$V_A$ , $V_B$		Human Body Model		$\pm 15$		kV
		IEC 61000-4-2		$\pm 4$		
All Other Pins		Human Body Model		$\pm 2$		kV

**Note 2:** All devices are tested at  $T_A = +25^\circ C$ . All temperature limits are guaranteed by design.

**Note 3:**  $V_{PEAK}$  is the average peak output voltage of  $V_A$  or  $V_B$ .

**Note 4:**  $V_{PEAK} = 9.5V + (N-1) \times 0.1575$ , (accuracy  $\pm 3\%$ ).

**Note 5:** Guaranteed monotonic.

# High-Voltage Liquid Lens Driver

## Timing Diagrams

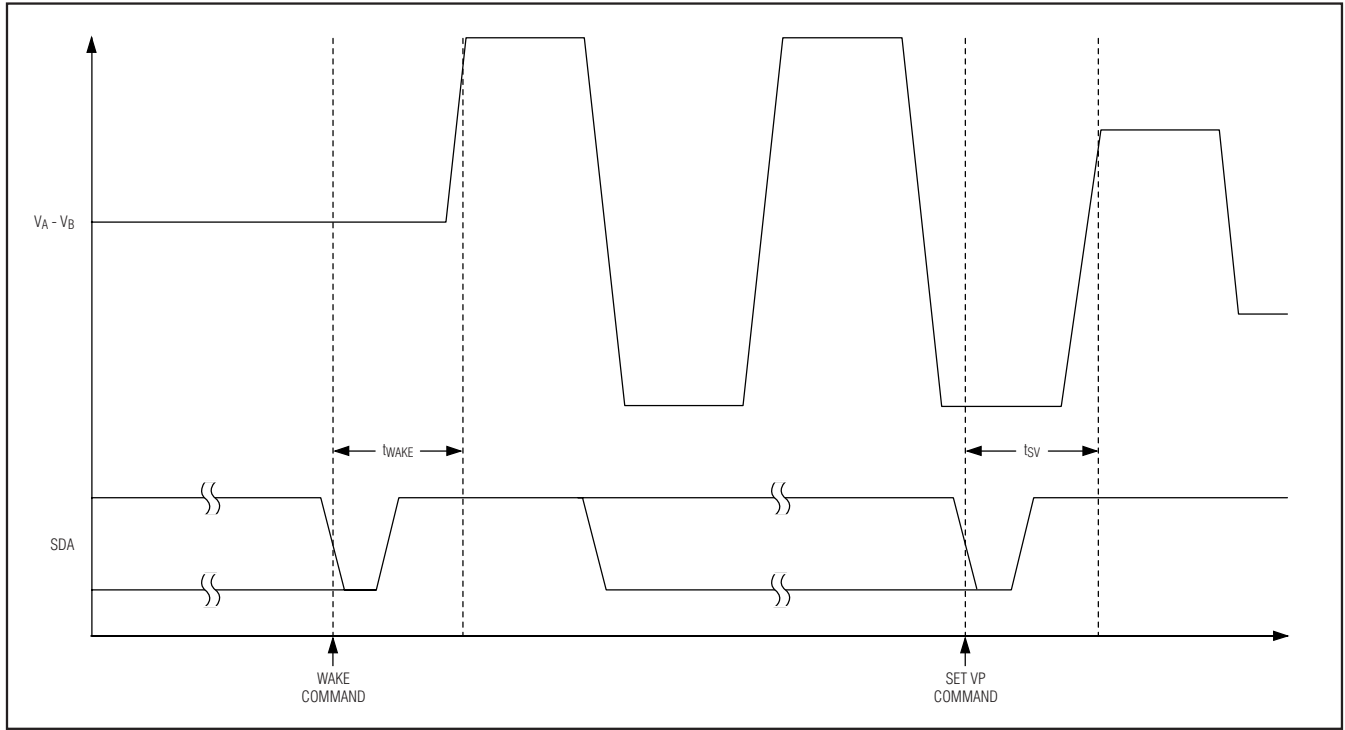

Figure 1. Wake-Up and Peak Output Voltage Settling Timing Diagram

# High-Voltage Liquid Lens Driver

## Timing Diagrams (continued)

MAX14515

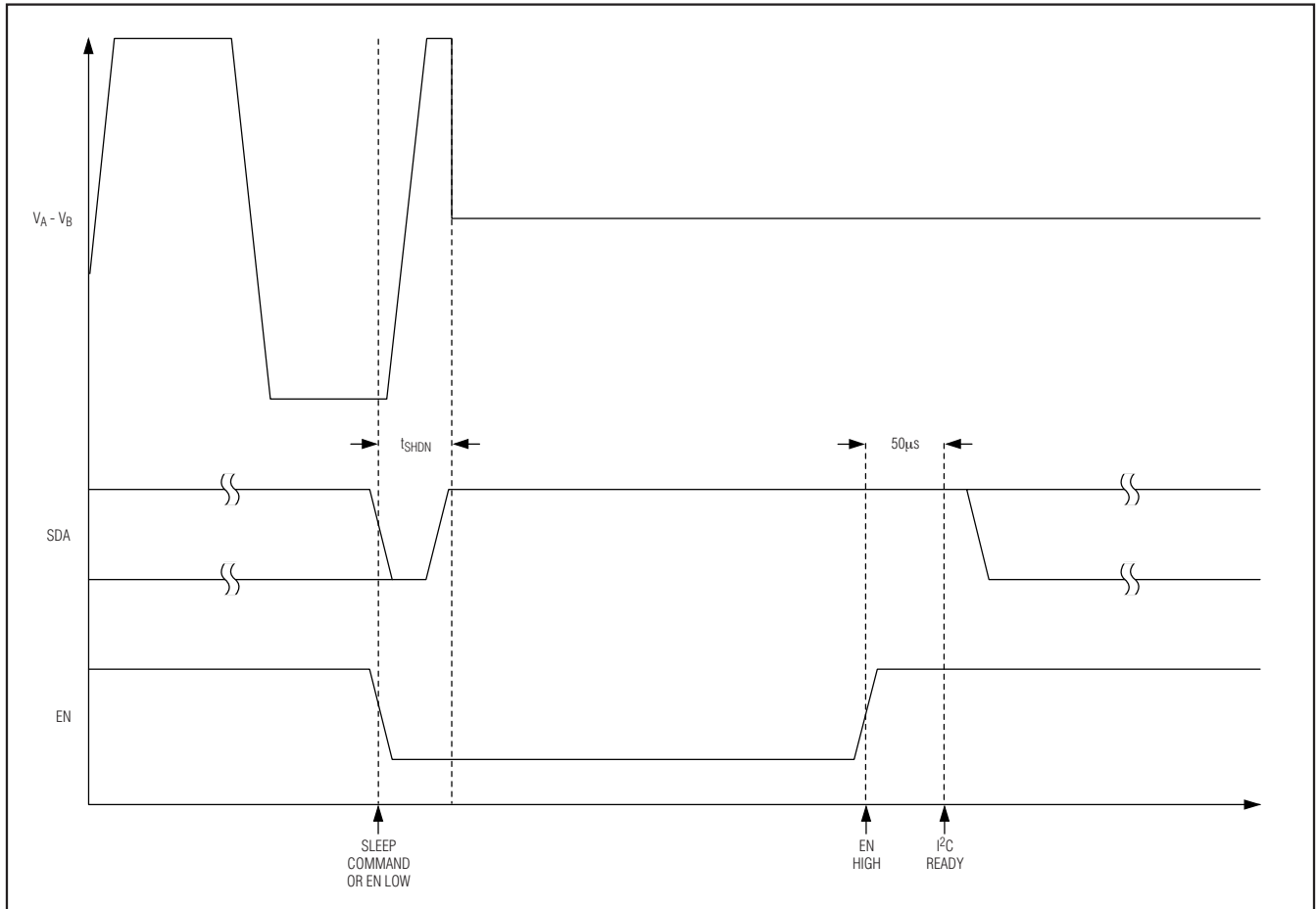

Figure 2. Shutdown/Sleep Mode Timing Diagram

# High-Voltage Liquid Lens Driver

## Typical Operating Characteristics

( $V_{DD} = +2.8V$ ,  $T_A = +25^\circ C$ ,  $C_{LENS} = 220pF$ , unless otherwise noted.)

**SUPPLY CURRENT vs. SUPPLY VOLTAGE**

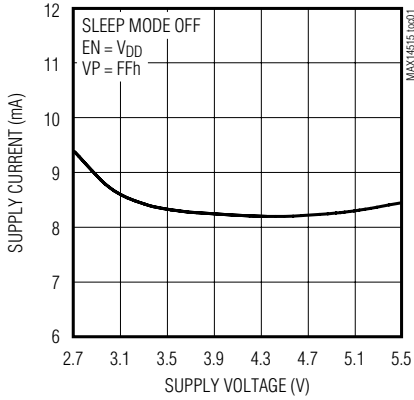

**SUPPLY CURRENT vs. TEMPERATURE**

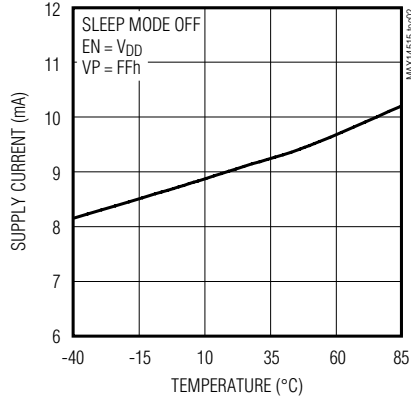

**SHUTDOWN SUPPLY CURRENT vs. SUPPLY VOLTAGE**

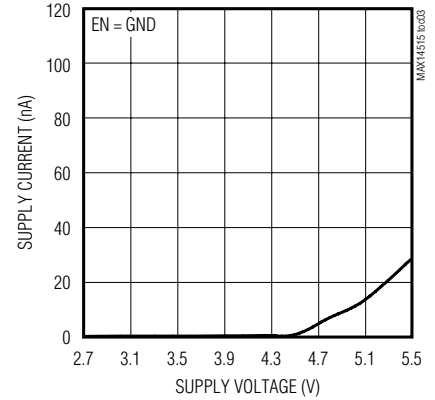

**SHUTDOWN SUPPLY CURRENT vs. TEMPERATURE**

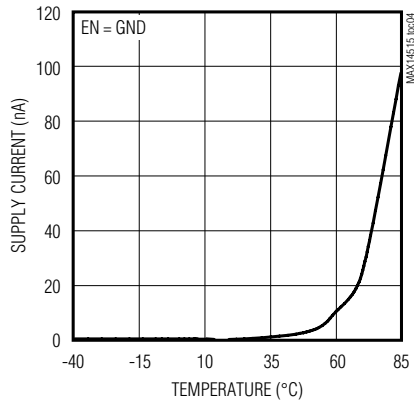

**SLEEP MODE SUPPLY CURRENT vs. SUPPLY VOLTAGE**

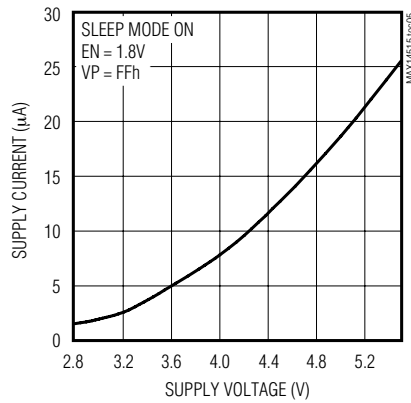

**SLEEP MODE SUPPLY CURRENT vs. SUPPLY VOLTAGE**

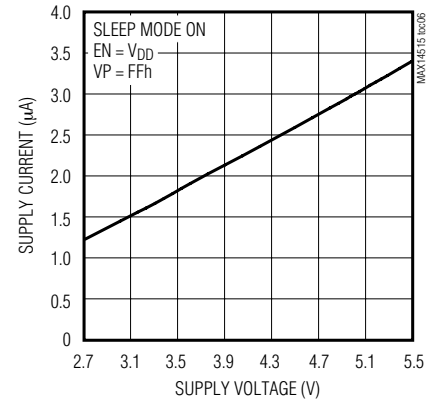

**SLEEP MODE SUPPLY CURRENT vs. TEMPERATURE**

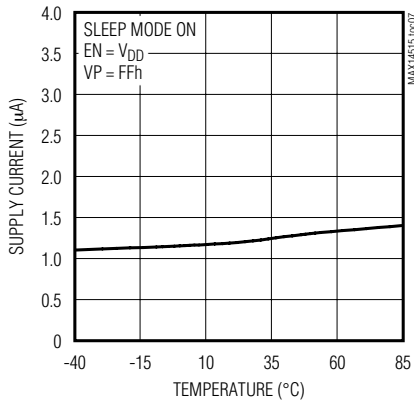

**RMS OUTPUT VOLTAGE vs. VP CODE**

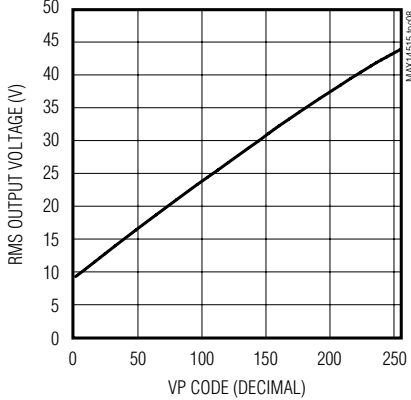

**RMS OUTPUT VOLTAGE vs. SUPPLY VOLTAGE**

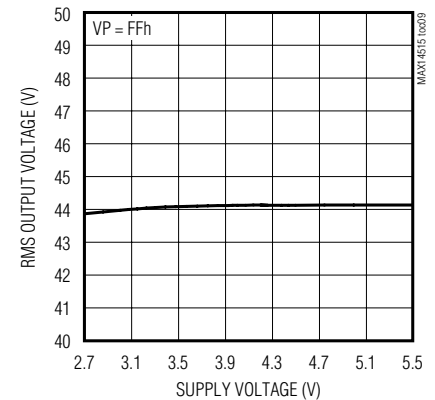

# High-Voltage Liquid Lens Driver

MAX14515

## Typical Operating Characteristics (continued)

( $V_{DD} = +2.8V$ ,  $T_A = +25^\circ C$ ,  $C_{LENS} = 220pF$ , unless otherwise noted.)

**RMS OUTPUT VOLTAGE vs. TEMPERATURE**

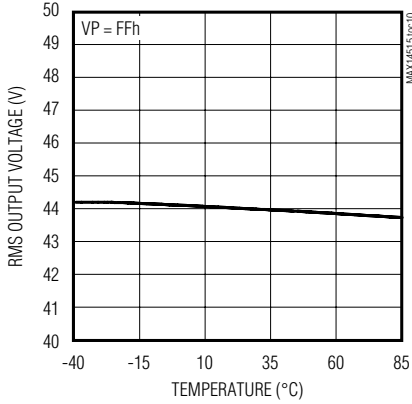

**PEAK OUTPUT VOLTAGE vs. SUPPLY VOLTAGE**

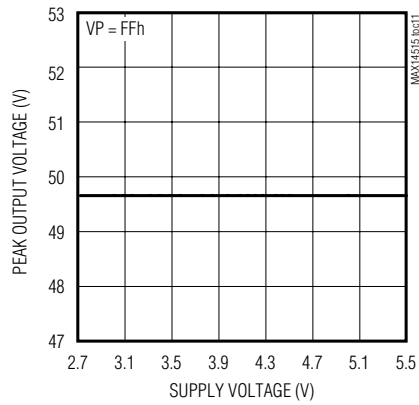

**PEAK OUTPUT VOLTAGE vs. TEMPERATURE**

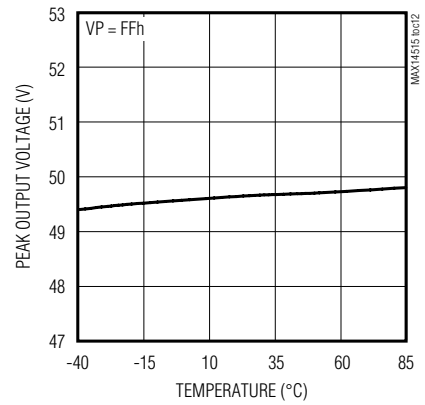

**OUTPUT FREQUENCY vs. SUPPLY VOLTAGE**

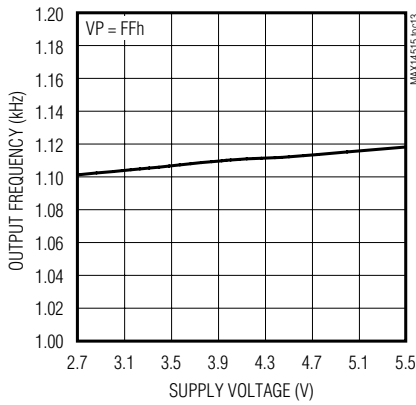

**OUTPUT FREQUENCY vs. TEMPERATURE**

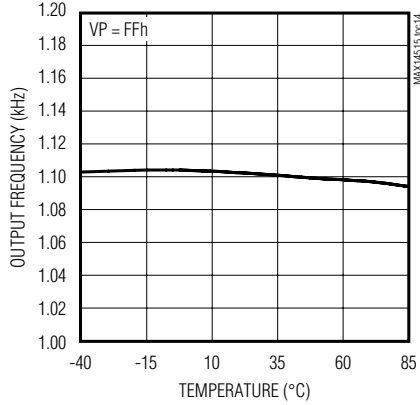

**OUTPUT VOLTAGE RIPPLE**

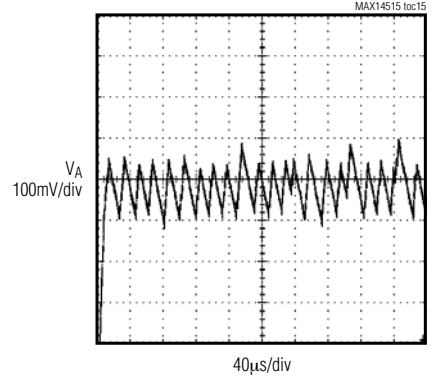

**POWER-UP/-DOWN**

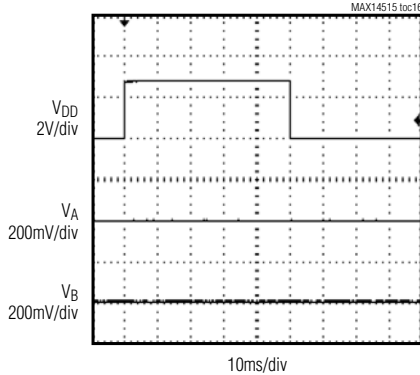

**POWER-UP/-DOWN**

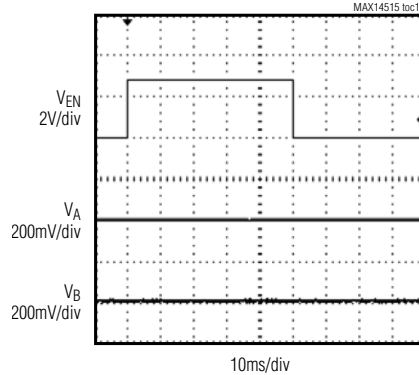

**SLEEP MODE ON**

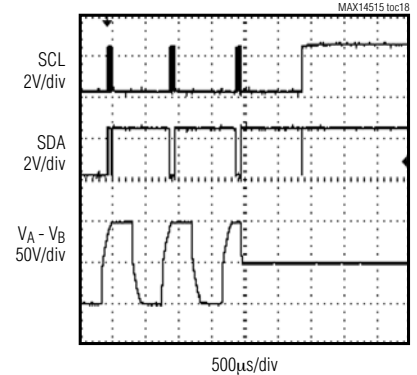

# High-Voltage Liquid Lens Driver

## Typical Operating Characteristics (continued)

( $V_{DD} = +2.8V$ ,  $T_A = +25^\circ C$ ,  $C_{LENS} = 220pF$ , unless otherwise noted.)

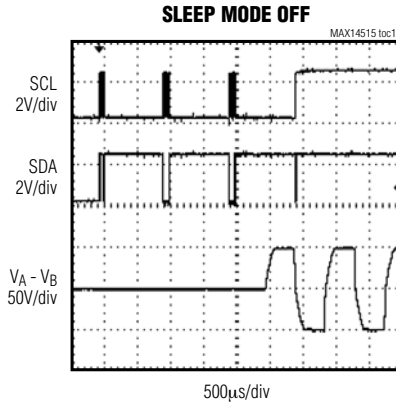

## Pin Description

PIN	NAME	FUNCTION
A1	SCL	I <sup>2</sup> C Open-Drain Serial Clock Input
B1	SDA	I <sup>2</sup> C Open-Drain Serial Data Input/Output
A2	EN	Enable Input. Drive EN high for normal operation. Drive EN low to enter shutdown mode.
B2	V <sub>DD</sub>	Input Supply Voltage. Bypass V <sub>DD</sub> to GND with a 0.1µF capacitor as close to the device as possible.
A3	GND	Ground
B3	V <sub>REF</sub>	Reference Voltage. Connect a 1µF ceramic capacitor from V <sub>REF</sub> to GND as close to the device as possible. V <sub>REF</sub> is nominally +5V. Do not use V <sub>REF</sub> to drive external circuitry.
A4	V <sub>A</sub>	High-Voltage Output. Connect to terminal 1 of liquid lens.
B4	V <sub>B</sub>	High-Voltage Output. Connect to terminal 2 of liquid lens.

## Functional Diagram

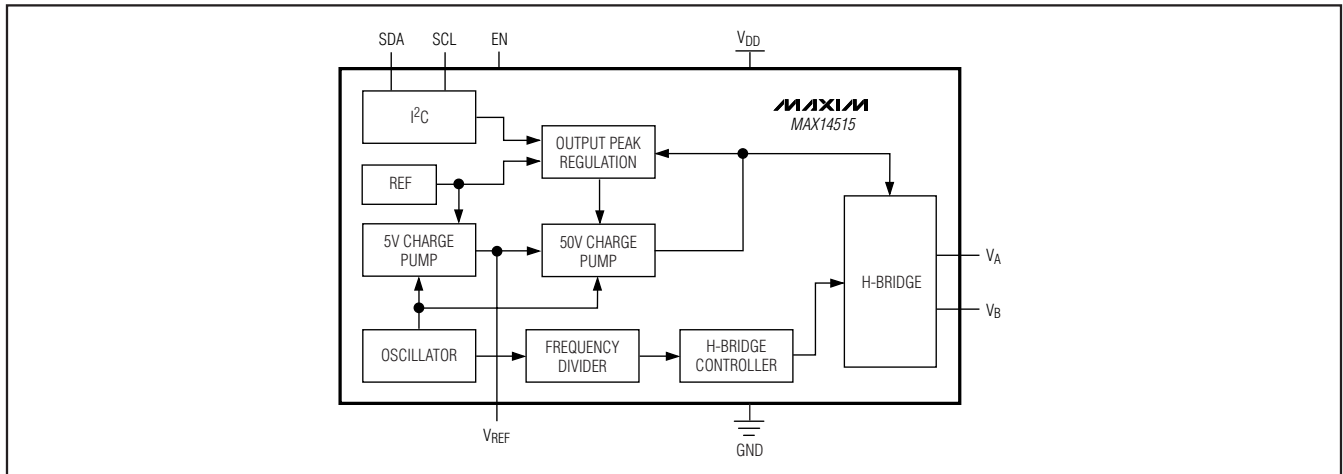



# High-Voltage Liquid Lens Driver

## Detailed Description

The MAX14515 high-voltage liquid lens driver utilizes a charge-pump-based boost converter and integrated H-bridge to provide a compact lens driver solution with minimal external components. This device features an 8-bit monotonic DAC controlled by a simple 2-wire I<sup>2</sup>C interface to set the peak amplitude of the high-voltage output.

### Power-On Reset

When the MAX14515 initially powers up, all the registers are cleared and the device is in sleep mode.

### High-Voltage Outputs (V<sub>A</sub>, V<sub>B</sub>)

Connect a liquid lens in between the high-voltage outputs (V<sub>A</sub>, V<sub>B</sub>) of the MAX14515. The peak output voltage of V<sub>A</sub> and V<sub>B</sub> is controlled by the value set in the high-voltage output register (VP). (See *Register Definition*). The internal H-bridge that drives V<sub>A</sub> and V<sub>B</sub> switches at 1.1kHz (typ).

### Reference Output (V<sub>REF</sub>)

V<sub>REF</sub> is the internal 5V charge-pump reference voltage of the MAX14515. Connect a 1μF ceramic capacitor from V<sub>REF</sub> to GND. V<sub>REF</sub> is not intended to drive external circuitry.

### Shutdown Mode (EN)

The MAX14515 features a shutdown mode that reduces supply current to less than 500nA (max). In shutdown, all registers are in a reset state, and the I<sup>2</sup>C interface is disabled. Drive EN low to place the device in shutdown mode. Drive EN high for normal operation. Driving EN rail-to-rail minimizes power consumption.

### Sleep Mode

When EN is high and the sleep mode bit ( $\overline{SM}$ ) in the power mode register (see *Register Definition*) is reset, the device is in sleep mode. During sleep mode, only the power-on reset circuit remains active. If no activity is detected on the I<sup>2</sup>C interface, current consumption is less than 3μA.

### I<sup>2</sup>C Serial Interface

#### Serial Addressing

The MAX14515 operates as a slave device that sends and receives data through an I<sup>2</sup>C-compatible 2-wire interface. The interface uses a serial-data line (SDA) and a serial-clock line (SCL) to achieve bidirectional communication between master(s) and slave(s). A master (typically a microcontroller) initiates all data transfers to and from the MAX14515, and generates the SCL clock that synchronizes the data transfer. The SDA line operates as both an input and an open-drain output. A pullup resistor is required on SDA. The SCL line

### Register Definition

DEVICE ADDRESS				WRITE	0xEC
				READ	0xED
FIELD NAME	READ WRITE	BITS	POWER-ON RESET	DESCRIPTION	
<b>POWER MODE (I<sup>2</sup>C ADDRESS = 0x00)</b>					
RSVD	Read/Write	[7:1]	0000 000	Reserved. All bits must be set to 0.	
$\overline{SM}$	Read/Write	0	0	Sleep Mode Bit 0 = Sleep Mode 1 = Normal Operation  All the registers keep the same values as before sleep unless a POR occurs.	
<b>HIGH-VOLTAGE OUTPUT LEVEL (I<sup>2</sup>C ADDRESS = 0x01)</b>					
VP(7:0)	Read/Write	[7:0]	0000 0000	Code 0x00 = 0V <sub>PEAK</sub> Code 0x01 = 10V <sub>PEAK</sub>  Code 0xFF = 49.5V <sub>PEAK</sub> , linear scale.  $V_{OUT(PEAK)} = 9.5V_{PEAK} + 0.1575V_{PEAK} \times (N - 1)$ where N = Code 0x01 to 0xFF in decimal. Accuracy (±3%).	

# High-Voltage Liquid Lens Driver

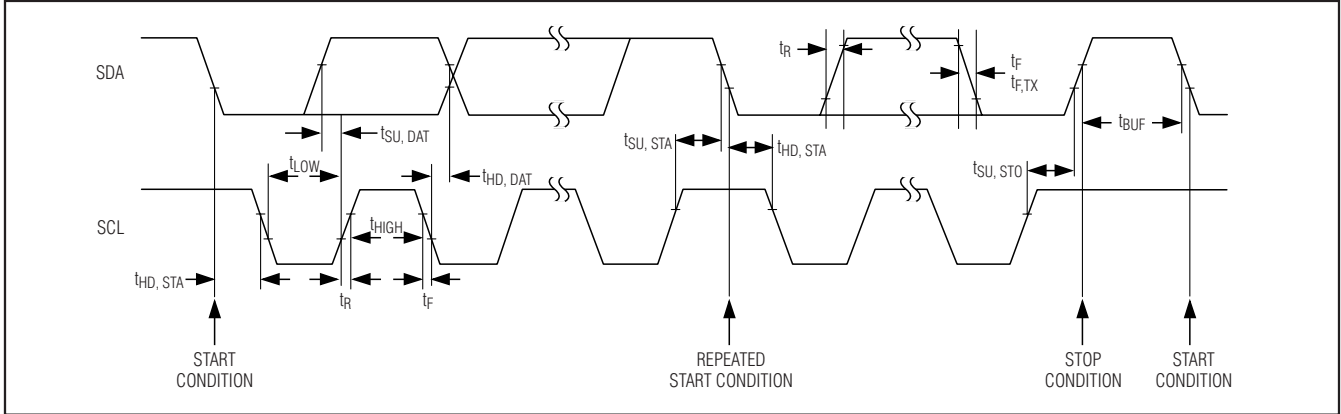

Figure 3. I<sup>2</sup>C Interface Timing Details

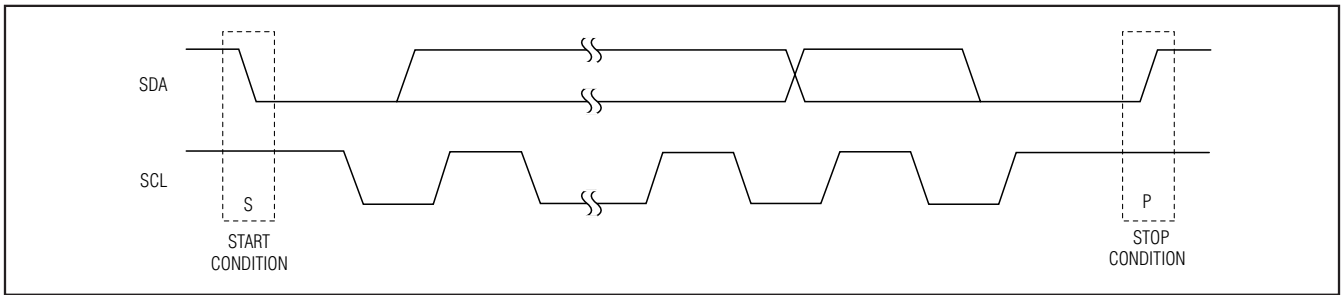

Figure 4. START and STOP Conditions

operates only as an input. A pullup resistor is required on SCL if there are multiple masters on the 2-wire interface, or if the master in a single-master system has an open-drain SCL output. Each transmission consists of a START condition sent by a master, followed by the MAX14515's 7-bit slave address plus R/W bit, a register address byte, 1 or more data bytes, and finally a STOP condition.

### START and STOP Conditions

Both SCL and SDA remain high when the interface is not busy. A master signals the beginning of a transmission with a START (S) condition by transitioning SDA from high to low while SCL is high (Figure 4). When the master has finished communicating with the slave, it issues a STOP (P) condition by transitioning SDA from low to high while SCL is high. The bus is then free for another transmission.

### Bit Transfer

One data bit is transferred during each clock pulse (Figure 5). The data on SDA must remain stable while SCL is high.

### Acknowledge

The acknowledge bit is a clocked 9th bit (Figure 6), which the recipient uses to handshake receipt of each byte of data. Thus, each byte transferred effectively requires 9 bits. The master generates the 9th clock pulse, and the recipient pulls down SDA during the high period of the clock pulse. When the master is transmitting to the MAX14515, it generates the acknowledge bit because the MAX14515 is the recipient. When the MAX14515 is transmitting to the master, the master generates the acknowledge bit because the master is the recipient.

# High-Voltage Liquid Lens Driver

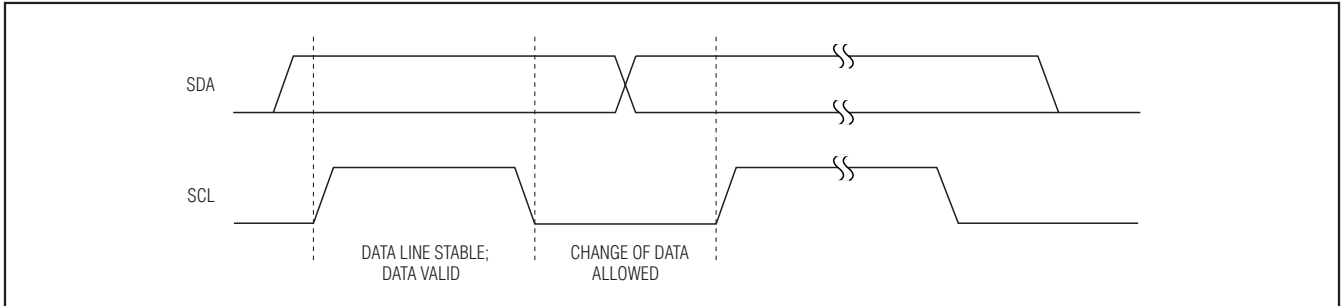

Figure 5. Bit Transfer

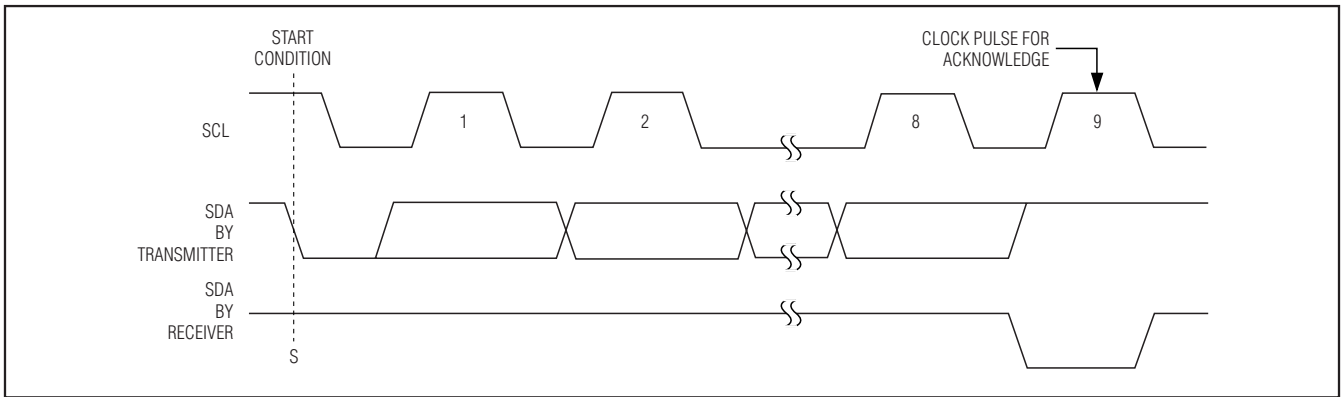

Figure 6. Acknowledge

### Slave Address

The MAX14515 has a 7-bit long slave address. The bit following a 7-bit slave address is the  $R/\bar{W}$  bit, which is low for a write command and high for a read command. The slave address is 0xEC for write commands and 0xED for read commands (Figure 7).

### Format for Writing

A write to the MAX14515 comprises the transmission of the slave address with the  $R/\bar{W}$  bit set to zero, followed by at least 1 byte of information. The first byte of information is the register address or command byte. The register address determines which register of the MAX14515 is to be written by the next byte, if received. If a STOP condition is detected after the register address is received, then the MAX14515 takes no further action beyond storing the register address (Figure 8). Any bytes received after the register address are data bytes. The first data byte goes into the register selected by the register address and subsequent data

bytes go into subsequent registers (Figure 9). If multiple data bytes are transmitted before a STOP condition, these bytes are stored in subsequent registers because the register address autoincrements.

### Format for Reading

The MAX14515 is read using the internally stored register address as an address pointer, the same way the stored register address is used as an address pointer for a write. The pointer autoincrements after each data byte is read using the same rules as for a write. Thus, a read is initiated by first configuring the register address by performing a write (Figure 10). The master can now read consecutive bytes from the MAX14515, with the first data byte being read from the register address pointed by the previously written register address. Once the master sounds a NACK, the MAX14515 stops sending valid data.

# High-Voltage Liquid Lens Driver

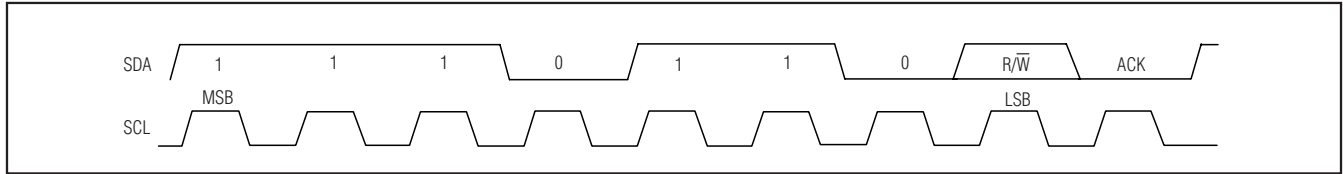

Figure 7. Slave Address

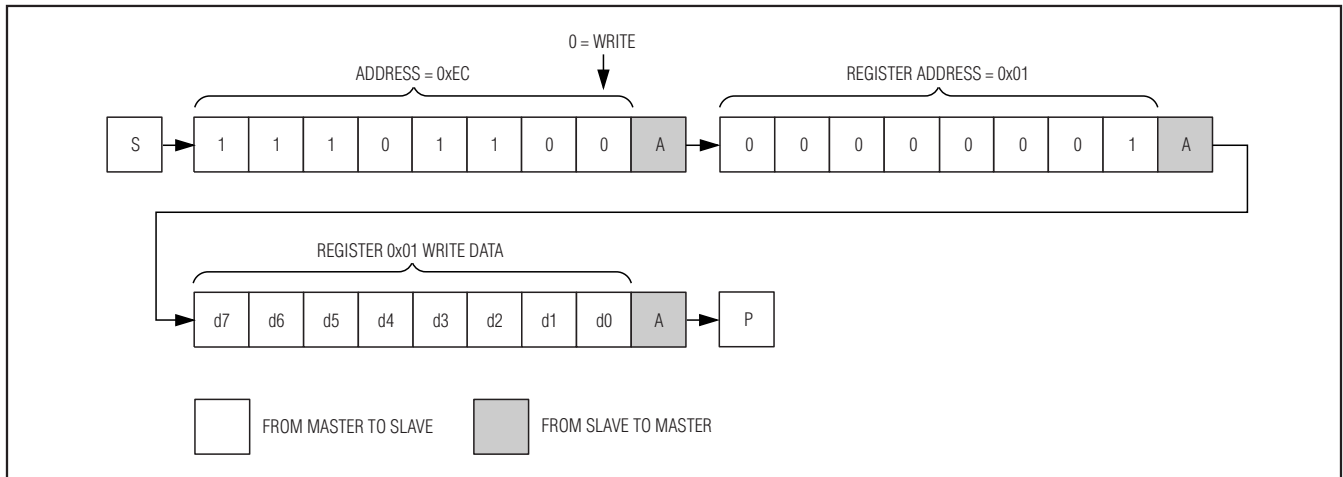

Figure 8. Format for I<sup>2</sup>C Write

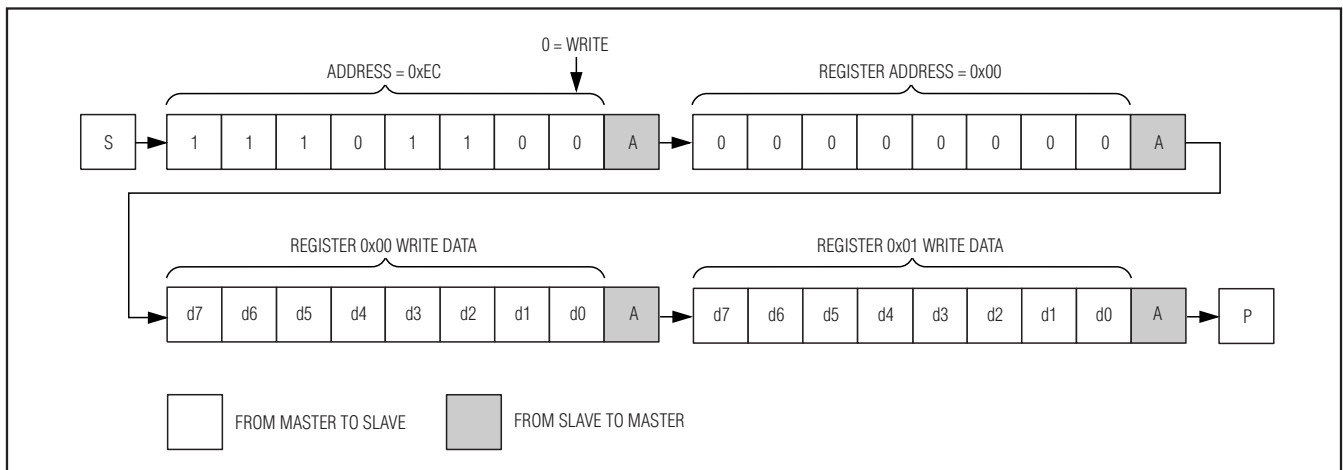

Figure 9. Format for Writing to Multiple Registers

# High-Voltage Liquid Lens Driver

MAX14515

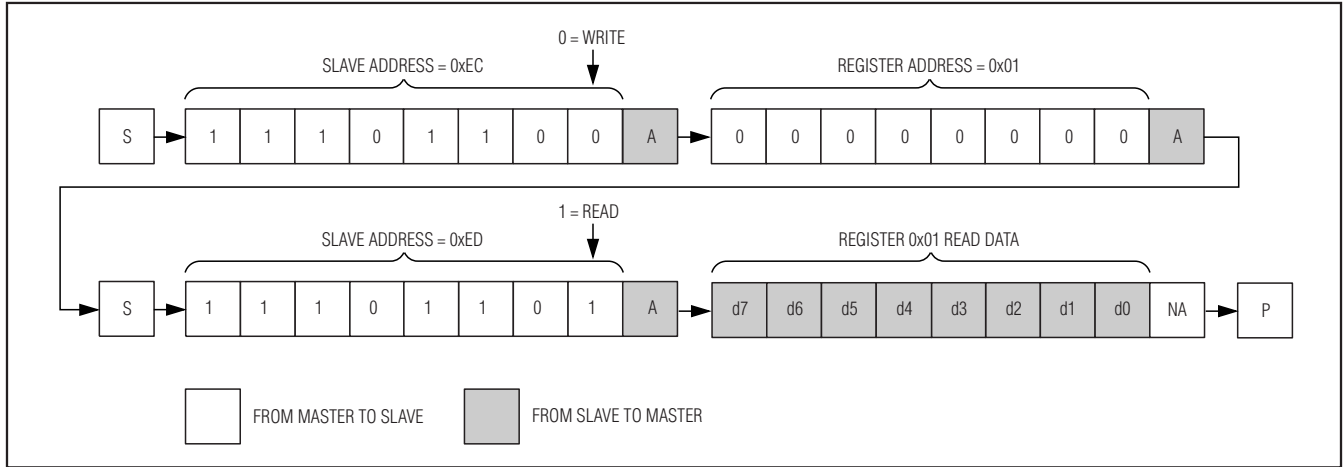

Figure 10. Format for Reading

## Applications Information

### Layout

Circuit board layout can significantly affect the performance of the MAX14515. Ensure that bypass capacitors are as close to the device as possible. Keep PCB traces as short as possible and minimize trace inductances to  $V_{DD}$ . Use large ground planes where possible.

### ESD Protection

ESD performance depends on a number of conditions. The MAX14515 is rated for  $\pm 15\text{kV}$  (Human Body Model) and  $\pm 4\text{kV}$  (IEC 61000-4-2 Contact) typical ESD resistance on  $V_A$  and  $V_B$ . All other pins are rated for  $\pm 2\text{kV}$  (HBM) typical ESD resistance.

### Human Body Model

Figure 11 shows the Human Body Model, and Figure 12 shows the current waveform it generates when discharged into a low impedance. This model consists of a  $100\text{pF}$  capacitor charged to the ESD voltage of interest that is then discharged into the device through a  $1.5\text{k}\Omega$  resistor.

### IEC 61000-4-2

The main difference between tests done using the Human Body Model and IEC 61000-4-2 is higher peak current in IEC 61000-4-2. Because series resistance is lower in the IEC 61000-4-2 ESD test model (Figure 13), the ESD-withstand voltage measured to this standard is generally lower than that measured using the Human Body Model. Figure 14 shows the current waveform for the IEC 61000-4-2 Level 4 ESD Contact Discharge test.

## Chip Information

PROCESS: CMOS

# High-Voltage Liquid Lens Driver

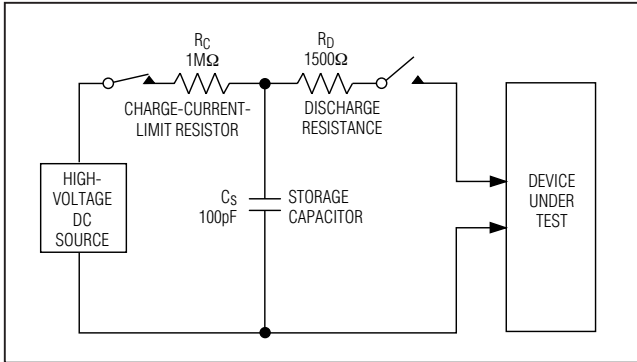

Figure 11. Human Body ESD Test Model

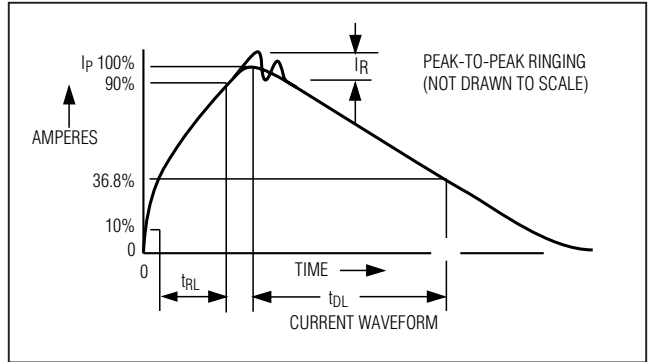

Figure 12. Human Body Current Waveform

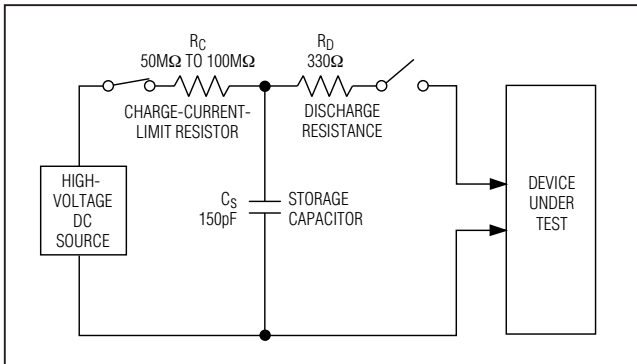

Figure 13. IEC 61000-4-2 ESD Test Model

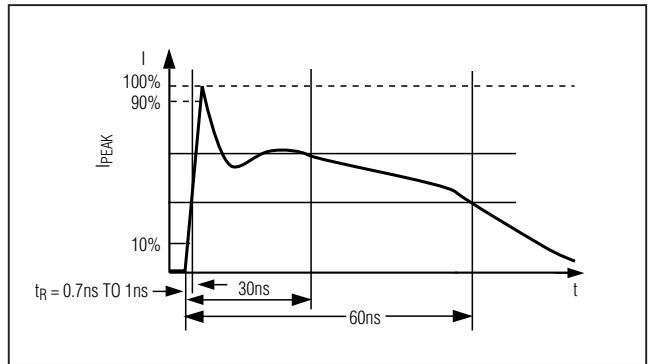

Figure 14. IEC 61000-4-2 ESD Generator Current Waveform

## Package Information

For the latest package outline information and land patterns, go to [www.maxim-ic.com/packages](http://www.maxim-ic.com/packages).

PACKAGE TYPE	PACKAGE CODE	DOCUMENT NO.
8 WLP	W81A2-1	<a href="#">21-0210</a>

Maxim cannot assume responsibility for use of any circuitry other than circuitry entirely embodied in a Maxim product. No circuit patent licenses are implied. Maxim reserves the right to change the circuitry and specifications without notice at any time.

14 **Maxim Integrated Products, 120 San Gabriel Drive, Sunnyvale, CA 94086 408-737-7600**



## Стандарт Электрон Связь

Мы молодая и активно развивающаяся компания в области поставок электронных компонентов. Мы поставляем электронные компоненты отечественного и импортного производства напрямую от производителей и с крупнейших складов мира.

Благодаря сотрудничеству с мировыми поставщиками мы осуществляем комплексные и плановые поставки широчайшего спектра электронных компонентов.

Собственная эффективная логистика и склад в обеспечивает надежную поставку продукции в точно указанные сроки по всей России.

Мы осуществляем техническую поддержку нашим клиентам и предпродажную проверку качества продукции. На все поставляемые продукты мы предоставляем гарантию .

Осуществляем поставки продукции под контролем ВП МО РФ на предприятия военно-промышленного комплекса России , а также работаем в рамках 275 ФЗ с открытием отдельных счетов в уполномоченном банке. Система менеджмента качества компании соответствует требованиям ГОСТ ISO 9001.

Минимальные сроки поставки, гибкие цены, неограниченный ассортимент и индивидуальный подход к клиентам являются основой для выстраивания долгосрочного и эффективного сотрудничества с предприятиями радиоэлектронной промышленности, предприятиями ВПК и научно-исследовательскими институтами России.

С нами вы становитесь еще успешнее!

### Наши контакты:

**Телефон:** +7 812 627 14 35

**Электронная почта:** [sales@st-electron.ru](mailto:sales@st-electron.ru)

**Адрес:** 198099, Санкт-Петербург,  
Промышленная ул, дом № 19, литера Н,  
помещение 100-Н Офис 331