

## ACBC-120 SERIES

### Alarm Controller and Battery Charger for pump control panels

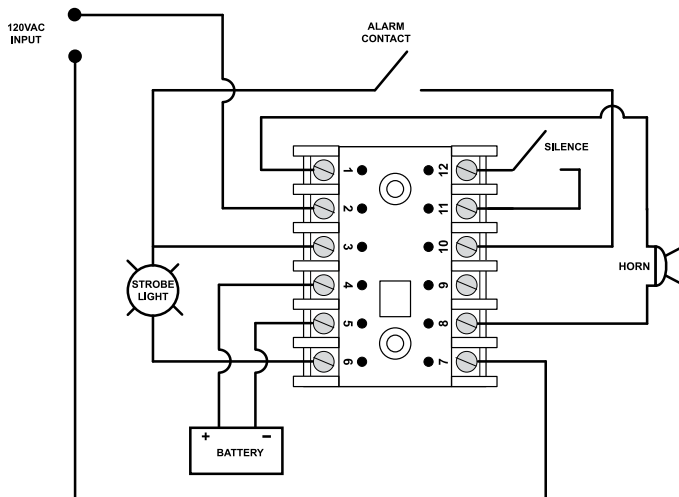

### Wiring Diagram



### Description

The ACBC-120 Series is a dual purpose alarm controller/battery charging unit. When there is a loss of 120VAC power, the ACBC-120's primary function as an alarm controller activates. When this power loss occurs, input power is switched to a 12VDC, lead-acid, rechargeable backup battery and a 12VDC alarm consisting of a strobe light and/or a horn is activated. The horn follows a 2 second on/2 second off pattern with a "horn silence" option to turn the sound off. An LED indicator on the unit also signals that the device has entered the alarm mode.

When 120VAC input is present the alarm circuit can be tested and the unit's secondary function as a 12VDC backup battery charger is activated. In fast charge mode, the unit has the capability to source up to 100mA of charging current. However, the device normally charges at a current of 14mA in maintenance mode. The alarm circuit can be tested by pressing the "test" button located on the front of the unit or by activating an external switch via the "alarm contact" pin.

The device has the ability to signal low battery voltage if the voltage drops below 10.5VDC. The device can also detect if no battery is present or if the battery is connected backwards. In either of these cases, the ACBC-120 will signal a battery error and will not attempt to charge.

#### Must use Model SD12-PC socket for UL Rating!

\*Note: Manufacturer's recommended screw terminal torque for the SD Series Sockets is 12 in.-lbs.

### Features & Benefits

FEATURES	BENEFITS
<b>Controls 12VDC alarm circuit</b>	Activates strobe and/or horn when power loss occurs
<b>Selectable fast charge mode</b>	Unit sources higher charging current up to 100mA (normal mode is 14mA)
<b>Trip delay timer</b>	Prevents nuisance tripping
<b>Battery fault detection and reverse polarity protection</b>	Signals if battery voltage drops below 10.5VDC and can detect if no battery is present or if the battery is connected backwards
<b>LED indication</b>	Visual indication of unit status or trip
<b>Test button</b>	Preventative maintenance check of the alarm circuit by pressing the test button on the unit or externally through alarm contact connection

### Ordering Information

MODEL	LINE VOTAGE	DESCRIPTION
ACBC-120	120VAC	Does not include SD12-PC socket for mounting
ACBC-120-SD	120VAC	Includes SD12-PC socket for mounting

### Accessories



**SD12-PC 12-pin Rectangle Socket**  
Rectangle Socket for the ACBC-120.  
12-pin surface mountable.

## ACBC-120 SERIES

### Specifications

#### Input Characteristics

<b>Supply Voltage</b>	
<b>AC Input Voltage</b>	120V +/-10%
<b>Frequency</b>	50/60Hz
<b>AC Input Current</b>	0.018A (max.) 0.003 (typical)
<b>AC Input Power</b>	2.4W (max.) fast charge current 0.4W (typical) maint. charge current

#### Functional Characteristics

##### Battery Charging

<b>Characteristics</b>	
<b>Acceptable Battery Type</b>	12V lead-acid rechargeable
<b>Fast Charge Current</b>	100mA +/-10%
<b>Maintenance Charge Current</b>	14mA +/-50%
<b>Low Battery Alert Level</b>	10.5V

##### Output Characteristics

<b>Strobe Light Alarm Output</b>	12VDC@1A (max.)
<b>Horn Alarm Output</b>	12VDC@1A (max.)

#### General Characteristics

<b>Temperature Range</b>	-40° to 60°C (-40° to 140°F)
--------------------------	------------------------------

#### Standards Passed

<b>Electrostatic Discharge (ESD)</b>	IEC 61000-4-2, Level 3, 6kV contact, 8kV air
<b>Radio Frequency, Radiated</b>	150MHz, 10V/m
<b>Fast Transient Burst</b>	IEC 61000-4-4, Level 4, 4kV input lines; 4kV signal lines

#### Safety Marks

##### UL

##### (SD12-PC socket required)

UL508 (File #E68520)

##### Dimensions

**H** 44.45 mm (1.75"); **W** 60.325 mm (2.375");

**D** 104.775 mm (4.125") (with socket)

##### Weight

0.7 lb. (11.2 oz., 317.51 g)

##### Mounting Method

Surface mount with #8 or #10 screws  
(plug into SD12-PC socket)

##### Socket Available

Model SD12-PC (UL Rating 600V)

The 600V socket can be surface mounted



## Стандарт Электрон Связь

Мы молодая и активно развивающаяся компания в области поставок электронных компонентов. Мы поставляем электронные компоненты отечественного и импортного производства напрямую от производителей и с крупнейших складов мира.

Благодаря сотрудничеству с мировыми поставщиками мы осуществляем комплексные и плановые поставки широчайшего спектра электронных компонентов.

Собственная эффективная логистика и склад в обеспечивает надежную поставку продукции в точно указанные сроки по всей России.

Мы осуществляем техническую поддержку нашим клиентам и предпродажную проверку качества продукции. На все поставляемые продукты мы предоставляем гарантию .

Осуществляем поставки продукции под контролем ВП МО РФ на предприятия военно-промышленного комплекса России , а также работаем в рамках 275 ФЗ с открытием отдельных счетов в уполномоченном банке. Система менеджмента качества компании соответствует требованиям ГОСТ ISO 9001.

Минимальные сроки поставки, гибкие цены, неограниченный ассортимент и индивидуальный подход к клиентам являются основой для выстраивания долгосрочного и эффективного сотрудничества с предприятиями радиоэлектронной промышленности, предприятиями ВПК и научно-исследовательскими институтами России.

С нами вы становитесь еще успешнее!

### Наши контакты:

**Телефон:** +7 812 627 14 35

**Электронная почта:** [sales@st-electron.ru](mailto:sales@st-electron.ru)

**Адрес:** 198099, Санкт-Петербург,  
Промышленная ул, дом № 19, литера Н,  
помещение 100-Н Офис 331