

# KSZ8775CLX



## Integrated 5-Port 10/100 Managed Ethernet Switch with Port 4 RMI and Port 5 RGMII/MII/RMII Interfaces

Revision 1.0

### General Description

The KSZ8775CLX is a highly integrated, Layer 2-managed, five-port switch with numerous features designed to reduce system cost. It is intended for cost-sensitive applications requiring three 10/100Mbps copper ports, one RMI on Port 4, and one 10/100/1000Mbps Gigabit uplink port on Port 5. The KSZ8775CLX incorporates a small package outline, the lowest power consumption with internal biasing, and on-chip termination. Its extensive set of features include enhanced power management, programmable rate limiting and priority ratio, tagged and port-based VLAN, port-based security and ACL rule-based packet filtering technology, QoS priority with four queues, management interfaces, enhanced MIB counters, high-performance memory bandwidth, and a shared memory-based switch fabric with non-blocking support. The KSZ8775CLX provides support for multiple CPU data interfaces to effectively address both current and emerging fast Ethernet and Gigabit Ethernet applications where the Port 5 GMAC can be configured to any of the RGMII, MII, and RMII modes.

The KSZ8775CLX product is built upon Micrel's industry-leading Ethernet's latest analog and digital technology, with features designed to offload host processing and streamline the overall design.

- Three integrated 10/100Base-T/TX MAC/PHYs
- One integrated 10/100Base-T/TX MAC with RMII interface
- One integrated 10/100/1000Base-T/TX GMAC with selectable RGMII, MII, and RMII interfaces
- Small 80-pin LQFP package

A robust assortment of power management features including energy-efficient Ethernet (EEE), power management event (PME), and wake-on-LAN (WoL) have been designed in to satisfy energy efficient environments.

All registers in the MAC/PHY units can be managed through the SPI interface. MIIM PHY registers can be accessed through the MDC/MDIO interface.

Datasheets and support documentation are available on Micrel's website at: [www.micrel.com](http://www.micrel.com).

### Functional Diagram

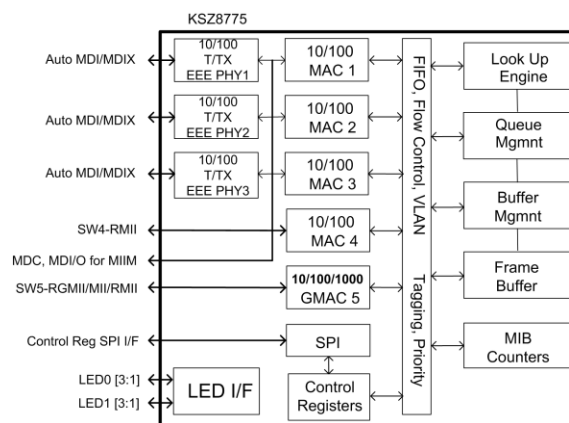

Figure 1. KSZ8775CLX Functional Block Diagram

Auto MDI/MDI-X is a trademark of Hewlett Packard.

Magic Packet is a trademark of Advanced Micro Devices.

LinkMD is a registered trademark of Micrel, Inc.

## Features

### Management Capabilities

- The KSZ8775CLX includes all the functions of a 10/100Base-T/TX switch system, which combines a switch engine, frame buffer management, address look-up table, queue management, MIB counters, media access controllers (MAC), and PHY transceivers
- Non-blocking store-and-forward switch fabric assures fast packet delivery by utilizing a 1024-entry forwarding table
- Port mirroring/monitoring/sniffing: ingress and/or egress traffic to any port
- MIB counters for fully compliant statistics gathering - 36 counters per port
- Hardware support for port-based flush and freeze command in MIB counter.
- Multiple loopback of remote, PHY, and MAC modes support for the diagnostics
- Rapid spanning tree support (RSTP) for topology management and ring/linear recovery

### Robust PHY Ports

- Four integrated IEEE 802.3/802.3u-compliant Ethernet transceivers supporting 10Base-T and 100Base-TX
- 802.1az EEE supported
- On-chip termination resistors and internal biasing for differential pairs to reduce power
- HP Auto MDI/MDI-X™ crossover support eliminates the need to differentiate between straight or crossover cables in applications

### MAC and GMAC Ports

- Four internal media access control (MAC1 to MAC4) units and one internal Gigabit media access control (GMAC5) unit
- RGMII, MII, or RMII interfaces support for the Port 5 GMAC5 with uplink and RMII interface for Port 4 MAC4
- 2kb jumbo packet support
- Tail tagging mode (one byte added before FCS) support on Port 5 to inform the processor which ingress port receives the packet and its priority
- Supports reduced media independent interface (RMII) with 50MHz reference clock output
- Supports media independent interface (MII) in either PHY mode or MAC mode on Port 5
- Micrel LinkMD® cable diagnostic capabilities for determining cable opens, shorts, and length

### Advanced Switch Capabilities

- Non-blocking store-and-forward switch fabric assures fast packet delivery by utilizing a 1024-entry forwarding table
- 64kb frame buffer RAM
- IEEE 802.1q VLAN support for up to 128 active VLAN groups (full-range 4096 of VLAN IDs)
- IEEE 802.1p/q tag insertion or removal on a per port basis (egress)
- VLAN ID tag/untag options on per port basis
- Fully compliant with IEEE 802.3/802.3u standards
- IEEE 802.3x full-duplex with force mode option and half-duplex back-pressure collision flow control
- IEEE 802.1w rapid spanning tree protocol support
- IGMP v1/v2/v3 snooping for multicast packet filtering
- QoS/CoS packets prioritization support: 802.1p, DiffServ-based and re-mapping of 802.1p priority field per port basis on four priority levels
- IPv4/IPv6 QoS support
- IPv6 multicast listener discovery (MLD) snooping
- Programmable rate limiting at the ingress and egress ports on a per port basis
- Jitter-free per-packet-based rate limiting support
- Tail tagging mode (one byte added before FCS) support on Port 5 to inform the processor which ingress port receives the packet and its priority
- Broadcast storm protection with percentage control (global and per port basis)
- 1kb entry forwarding table with 64kb frame buffer
- Four priority queues with dynamic packet mapping for IEEE 802.1p, IPv4 ToS (DIFFSERV), IPv6 traffic class, etc.
- Supports wake-on-LAN (WoL) using AMD's Magic Packet™
- VLAN and address filtering
- Supports 802.1x port-based security, authentication, and MAC-based authentication via access control lists (ACL)
- Provides port-based and rule-based ACLs to support Layer 2 MAC SA/DA address, Layer 3 IP address and IP mask, Layer 4 TCP/UDP port number, IP protocol, TCP flag, and compensation for the port security filtering
- Ingress and egress rate limit based on bit per second (bps) and packet-based rate limiting (pps)

### Configuration Registers Access

- High speed (4-wire, up to 50MHz) interface (SPI) to access all internal registers
- MII management interface (MIIM, MDC/MDIO 2-wire) to access all PHY registers per clause 22.2.4.5 of the IEEE 802.3 specification

- I/O pin strapping facility to set certain register bits from I/O pins during reset time
- Control registers configurable on-the-fly

### **Power and Power Management**

- Full-chip software power down (all registers value are not saved and strap-in value will re-strap after release of the power down)
- Per-port software power down
- Energy detect power down (EDPD), which disables the PHY transceiver when cables are removed
- Supports IEEE P802.3az energy-efficient Ethernet to reduce power consumption in transceivers in LPI state even though cables are not removed
- Dynamic clock tree control to reduce clocking in areas not in use
- Low power consumption without extra power consumption on transformers
- Voltages: Using external LDO power supplies.
  - Analog VDDAT 3.3V
  - VDDIO supports 3.3V, 2.5V, and 1.8V
  - Low 1.2V voltage for analog and digital core power
- Wake-on-LAN support with configurable packet control

### **Additional Features**

- Single 25MHz +50ppm reference clock requirement
- Comprehensive programmable two LED indicator support for link, activity, full/half-duplex, and 10/100 speed

### **Packaging and Environmental**

- Commercial temperature range: 0°C to +70°C
- Industrial temperature range: –40°C to +85°C
- Package available in an 80-pin lead free (RoHS) LQFP form factor
- Supports HBM ESD rating of 5kV
- 0.065µm CMOS technology for lower power consumption

### **Applications**

- Industrial Ethernet applications that employ IEEE 802.3-compliant MACs (Ethernet/IP, Profinet, MODBUS TCP, etc)
- VoIP phone
- Set-top/game box
- Automotive
- Industrial control
- IPTV POF
- SOHO residential gateway with full wire speed of four LAN ports
- Broadband gateway/firewall/VPN
- Integrated DSL/cable modem
- Wireless LAN access point + gateway
- Standalone 10/100 switch
- Networked measurement and control systems

## Ordering Information

Part Number	Temperature Range	Package	Lead Finish/Grade
KSZ8775CLXCC	0°C to 70°C	80-Pin LQFP	Pb-Free/Commercial
KSZ8775CLXIC	-40°C to +85°C	80-Pin LQFP	Pb-Free/Industrial
KSZ8775CLX-EVAL	Evaluation Board		

## Revision History

Revision	Date	Summary of Changes
1.0	6/4/14	Initial document created.

## Contents

List of Figures .....	8
List of Tables .....	9
Pin Configuration .....	10
Pin Description .....	11
Strap-In Options .....	17
Introduction.....	19
Functional Overview: Physical Layer (PHY) .....	19
100BASE-TX Transmit .....	19
100BASE-TX Receive .....	19
PLL Clock Synthesizer.....	19
Scrambler/Descrambler (100BASE-TX Only).....	20
10BASE-T Transmit.....	20
10BASE-T Receive.....	20
MDI/MDI-X Auto Crossover .....	20
<i>Straight Cable</i> .....	21
<i>Crossover Cable</i> .....	21
Auto-Negotiation .....	22
LinkMD <sup>®</sup> Cable Diagnostics.....	23
<i>Access</i> .....	23
<i>Usage</i> .....	23
<i>A LinkMD<sup>®</sup> Example</i> .....	24
On-Chip Termination and Internal Biasing .....	24
Functional Overview: Media Access Controller (MAC) .....	25
Media Access Controller Operation .....	25
<i>Inter-Packet Gap (IPG)</i> .....	25
<i>Backoff Algorithm</i> .....	25
<i>Late Collision</i> .....	25
<i>Illegal Frames</i> .....	25
<i>Flow Control</i> .....	25
<i>Half-Duplex Back Pressure</i> .....	26
<i>Broadcast Storm Protection</i> .....	26
Functional Overview: Switch Core .....	27
Learning .....	27
Migration .....	27
Aging.....	27
Forwarding.....	27
Switching Engine .....	28
Functional Overview: Power .....	29
Functional Overview: Power Management .....	29
Normal Operation Mode .....	29
Energy Detect Mode .....	29
Soft Power-Down Mode.....	30
Port-Based Power-Down Mode .....	30
Energy-Efficient Ethernet (EEE) .....	30
<i>LPI Signalling</i> .....	31
<i>LPI Assertion</i> .....	31

<i>LPI Detection</i> .....	31
<i>PHY LPI Transmit Operation</i> .....	31
<i>PHY LPI Receive Operation</i> .....	32
<i>Negotiation with EEE Capability</i> .....	32
Wake-on-LAN (WoL) .....	32
<i>Direction of Energy</i> .....	33
<i>Direction of Link-up</i> .....	33
<i>Magic Packet™</i> .....	33
<i>Example of Magic Packet:</i> .....	33
Interrupt (INT_N/PME_N) .....	33
Functional Overview: Interfaces .....	34
Configuration Interface .....	34
<i>SPI Slave Serial Bus Configuration</i> .....	34
<i>MII Management Interface (MIIM)</i> .....	37
Switch Port 4 MAC Interface .....	38
<i>Port 4 MAC4 SW4-RMII Interface</i> .....	38
Switch Port 5 GMAC Interface .....	39
<i>Standard Media Independent Interface (MII)</i> .....	39
<i>Reduced Media Independent Interface (RMII)</i> .....	39
<i>Reduced Gigabit Media Independent Interface (RGMII)</i> .....	39
<i>Port 5 GMAC5 SW5-RGMII Interface</i> .....	40
<i>Port 5 GMAC5 SW5-MII Interface</i> .....	41
<i>Port 5 GMAC5 SW5-RMII Interface</i> .....	42
Functional Overview: Advanced Functionality .....	43
QoS Priority Support .....	43
<i>Port-Based Priority</i> .....	43
<i>802.1p-Based Priority</i> .....	43
<i>DiffServ-Based Priority</i> .....	44
Spanning Tree Support .....	44
Rapid Spanning Tree Support .....	46
Tail Tagging Mode .....	47
IGMP Support .....	48
IPv6 MLD Snooping .....	48
Port Mirroring Support .....	48
VLAN Support .....	49
Rate Limiting Support .....	50
<i>Ingress Rate Limit</i> .....	51
<i>Egress Rate Limit</i> .....	51
<i>Transmit Queue Ratio Programming</i> .....	51
VLAN and Address Filtering .....	52
IEEE 802.1x Port-Based Security .....	52
<i>Authentication Register and Programming Model</i> .....	53
Access Control List (ACL) Filtering .....	53
<i>Access Control Lists</i> .....	53
<i>Matching Fields</i> .....	54
<i>Action Field</i> .....	55

<i>Processing Field</i> .....	56
<i>Denial of Service (DoS) Attack Prevention via ACL</i> .....	56
Device Registers .....	57
Direct Register Description .....	59
Global Registers .....	61
Port Registers .....	68
Advanced Control Registers .....	81
Indirect Register Description .....	101
Static MAC Address Table .....	102
VLAN Table .....	104
Dynamic MAC Address Table .....	107
PME Indirect Registers .....	109
Programming Examples .....	110
<i>Read Operation</i> .....	110
<i>Write Operation</i> .....	110
ACL Rule Table and ACL Indirect Registers .....	111
ACL Register and Programming Model .....	111
ACL Indirect Registers .....	112
<i>Read Operation</i> .....	121
<i>Write Operation</i> .....	122
EEE Indirect Registers .....	123
Programming Examples .....	129
<i>Read Operation</i> .....	129
<i>Write Operation</i> .....	129
Management Information Base (MIB) Counters .....	130
MIIM Registers .....	134
Absolute Maximum Ratings .....	138
Operating Ratings .....	138
Electrical Characteristics .....	138
Timing Diagram .....	141
RGMII Timing .....	141
MII Timing .....	142
RMII Timing .....	144
SPI Timing .....	145
Auto-Negotiation Timing .....	147
MDC/MDIO Timing .....	148
Power-Down/Power-Up and Reset Timing .....	149
Reset Circuit Diagram .....	150
Selection of Isolation Transformer .....	151
Selection of Reference Crystal .....	151
Package Information .....	152

## List of Figures

Figure 1. KSZ8775CLX Functional Block Diagram .....	1
Figure 2. 80-Pin LQFP .....	10
Figure 3. Typical Straight Cable Connection .....	21
Figure 4. Typical Crossover Cable Connection .....	21
Figure 5. Auto-Negotiation and Parallel Operation .....	22
Figure 6. Destination Address Look-up and Resolution Flow Chart .....	28
Figure 7. EEE Transmit and Receive Signaling Paths .....	30
Figure 8. Traffic Activity and EEE LPI Operations .....	32
Figure 9. SPI Access Timing .....	35
Figure 10. SPI Multiple Access Timing .....	36
Figure 11. 802.1p Priority Field Format .....	43
Figure 12. Tail Tag Frame Format .....	47
Figure 13. ACL Format .....	54
Figure 14. Interface and Register Mapping .....	57
Figure 15. ACL Table Access .....	111
Figure 16. RGMII v2.0 Specification .....	141
Figure 17. MAC Mode MII Timing – Data Received from MII .....	142
Figure 18. MAC Mode MII Timing – Data Transmitted from MII .....	142
Figure 19. PHY Mode MII Timing – Data Received from MII .....	143
Figure 20. PHY Mode MII Timing – Data Transmitted from MII .....	143
Figure 21. RMII Timing – Data Received from RMII .....	144
Figure 22. RMII Timing – Data Transmitted to RMII .....	144
Figure 23. SPI Input Timing .....	145
Figure 24. SPI Output Timing .....	146
Figure 25. Auto-Negotiation Timing Diagram .....	147
Figure 26. MDC/MDIO Timing Diagram .....	148
Figure 27. Reset Timing Diagram .....	149
Figure 28. Recommended Reset Circuit .....	150
Figure 29. Recommended Circuit for Interfacing with CPU/FPGA Reset .....	150
Figure 30. 80-Pin LQFP .....	152



## List of Tables

Table 1. MDI/MDI-X Pin Definitions .....	20
Table 2. Internal Function Block Status .....	29
Table 3. Available Interfaces.....	34
Table 4. SPI Connections .....	34
Table 5. MII Management Interface Frame Format .....	37
Table 6. Port 4 SW4-RMII Connection.....	38
Table 7. Signals of RGMII/MII/RMII .....	39
Table 8. Port 5 SW5-RGMII Connection.....	40
Table 9. Port 5 SW5-RGMII Clock Delay Configuration with Connection Partner.....	40
Table 10. Port 5 SW5-MII Connection .....	41
Table 11. Port 5 SW5-RMII Connection.....	42
Table 12. Port Settings and Software Actions for Spanning Tree States .....	45
Table 13. Port Settings and Software Actions for Rapid Spanning Tree States.....	46
Table 14. Tail Tag Rules .....	47
Table 15. FID+DA Look-Up in the VLAN Mode .....	49
Table 16. FID+SA Look-Up in the VLAN Mode .....	49
Table 17. 10/100/1000Mbps Rate Selection for the Rate Limit .....	50
Table 18. Mapping of Functional Areas within the Address Space .....	58
Table 19. Format of Static MAC Addresses for Reads (32 Entries) .....	102
Table 20. Format of Static MAC Addresses for Writes (32 Entries) .....	103
Table 21. VLAN Table.....	104
Table 22. Indirect Registers and VLAN ID .....	106
Table 23. Dynamic MAC Address Table .....	107
Table 24. PME Indirect Registers .....	109
Table 25. Temporary Storage for 14-Bytes ACL Rules .....	112
Table 26. Temporary Storage for 14-byte ACL Rules .....	120
Table 27. ACL Read and Write Control .....	121
Table 28. EEE Global Registers .....	123
Table 29. EEE Port Registers .....	124
Table 30. Port 1 MIB Counter Indirect Memory Offerts .....	130
Table 31. Format of Per-Port MIB Counters .....	131
Table 32. All Port-Dropped Packet MIB Counters .....	131
Table 33. Format of Per-Port Total RX/TX Bytes MIB Counters .....	132
Table 34. Format of All Port Dropped Packet MIB Counters .....	132
Table 36. RGMII v2.0 Specification .....	141
Table 37. MAC Mode MII Timing Parameters.....	142
Table 38. PHY Mode MII Timing Parameters .....	143
Table 39. RMII Timing Parameters .....	144
Table 40. SPI Input Timing Parameters.....	145
Table 41. SPI Output Timing Parameters .....	146
Table 42. Auto-Negotiation Timing Parameters.....	147
Table 43. MDC/MDIO Timing Parameters .....	148
Table 44. Reset Timing Parameters .....	149
Table 45. Transformer Selection Criteria .....	151
Table 46. Qualified Magnetic Vendors.....	151
Table 47. Typical Reference Crystal Characteristics.....	151

# Pin Configuration

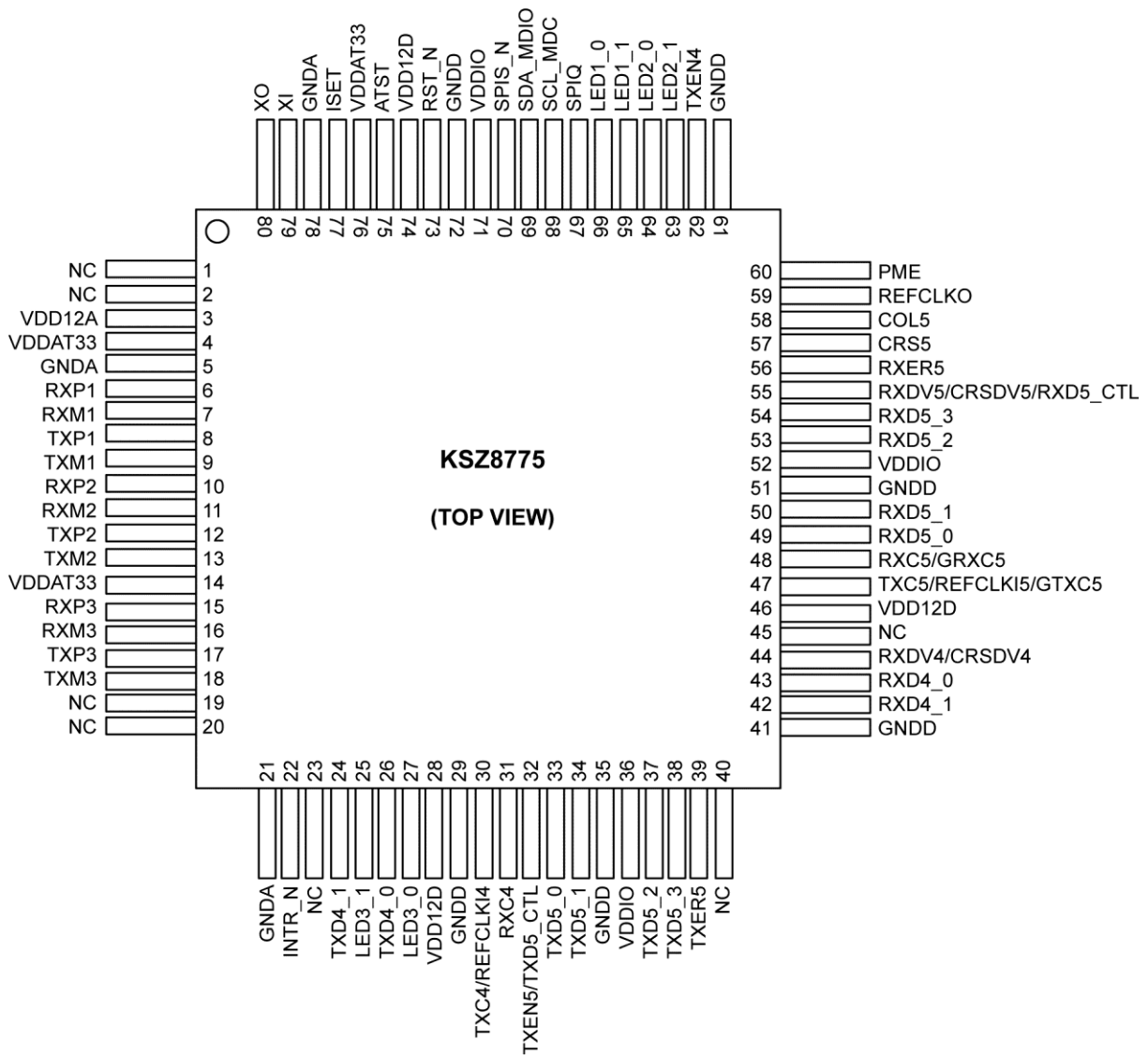

Figure 2. 80-Pin LQFP

## Pin Description

Pin Number	Pin Name	Type <sup>(1)</sup>	Port	Pin Function <sup>(2)</sup>
1	NC	NC		No connect
2	NC	NC		No connect
3	VDD12A	P		1.2V core power
4	VDDAT	P		3.3V analog power
5	GNDA	GND		Analog ground
6	RXP1	I	1	Port 1 physical receive signal + (differential).
7	RXM1	I	1	Port 1 physical receive signal - (differential).
8	TXP1	O	1	Port 1 physical transmit signal + (differential).
9	TXM1	O	1	Port 1 physical transmit signal - (differential).
10	RXP2	I	2	Port 2 physical receive signal + (differential).
11	RXM2	I	2	Port 2 physical receive signal - (differential).
12	TXP2	O	2	Port 2 physical transmit signal + (differential)
13	TXM2	O	2	Port 2 physical transmit signal - (differential).
14	VDDAT	P		3.3V analog power
15	RXP3	I	3	Port 3 physical receive signal + (differential).
16	RXM3	I	3	Port 3 physical receive signal - (differential).
17	TXP3	O	3	Port 3 physical transmit signal + (differential).
18	TXM3	O	3	Port 3 physical transmit signal – (differential).
19	NC	NC		No connect
20	NC	NC		No connect
21	GNDA	GND		Analog ground
22	INTR_N	OPU		<b>Interrupt.</b> Active low. This pin is an open-drain output pin.
23	NC	NC		No connect
24	TXD4_1	IPD	4	<b>RMII:</b> Port 4 RMII transmit bit [1].

### Notes:

- P = Power supply.  
 I = Input.  
 O = Output.  
 I/O = Bi-directional.  
 GND = Ground.  
 IPU = Input with internal pull-up.  
 IPD = Input with internal pull-down.  
 IPD/O = Input with internal pull-down during reset, output pin otherwise.  
 IPU/O = Input with internal pull-up during reset, output pin otherwise.  
 OTRI = Output tri-stated.
- PU = Strap pin pull-up.  
 PD = Strap pin pull-down.  
 NC = No connect or tied to ground for this product.

**Pin Description (Continued)**

Pin Number	Pin Name	Type <sup>(1)</sup>	Port	Pin Function <sup>(2)</sup>
25	LED3_1	IPU/O	3	<b>Port 3 LED Indicator 1.</b> See global Register 11 bits [5:4] for details. Strap option: Switch Port 5 GMAC5 interface mode select by LED3[1:0] 00 = MII for SW5-MII 01 = RMI for SW5-RMII 10 = Reserved 11 = RGMII for SW5-RGMII (default)
26	TXD4_0	IPD	4	<b>RMII:</b> Port 4 RMII transmit bit [0]
27	LED3_0	IPU/O	3	<b>Port 3 LED Indicator 0.</b> See global Register 11 bits [5:4] for details. Strap option: see LED3_1
28	VDD12D	P		1.2V core power.
29	GNDD	GND		Digital ground.
30	TXC4/REFCLKI4	I/O	4	<b>Port 4 Switch MAC4 SW4-RMII Reference Clock Input</b> RMII: Input for receiving 50MHz clock in normal mode.
31	RXC4	I/O	4	Port 4 Switch MAC4 SW4-RMII reference clock out: RMII: Output 50MHz reference clock for the receiving/transmit in the clock mode.
32	TXEN5/TXD5_CTL	IPD	5	<b>MII/RMII:</b> Port 5 switch transmit enable. <b>RGMII:</b> Transmit data control.
33	TXD5_0	IPD	5	<b>RGMII/MII/RMII:</b> Port 5 switch transmit bit [0].
34	TXD5_1	IPD	5	<b>RGMII/MII/RMII:</b> Port 5 switch transmit bit [1].
35	GNDD	GND		Digital ground.
36	VDDIO	P		3.3V, 2.5V, or 1.8V digital V <sub>DD</sub> for digital I/O circuitry.
37	TXD5_2	IPD	5	<b>RGMII/MII:</b> Port 5 switch transmit bit [2]. <b>RMII:</b> No connection.
38	TXD5_3	IPD	5	<b>RGMII/MII:</b> Port 5 switch transmit bit [3]. <b>RMII:</b> No connection.
39	TXER5	IPD	5	<b>MII:</b> Port 5 switch transmit error. <b>RGMII/RMII:</b> No connection.
40	NC	NC		No connect
41	GNDD	GND		Digital ground
42	RXD4_1	IPD/O	4	<b>RMII:</b> Port 4 SW4-RMII receive bit [1]

**Pin Description (Continued)**

Pin Number	Pin Name	Type <sup>(1)</sup>	Port	Pin Function <sup>(2)</sup>
44	RXDV4/CRSDV4	IPD/O	4	<b><u>RMII:</u></b> CRSDV4 is for Port 4 RMII carrier sense/receive data valid output.
45	NC	NC		No connect
46	VDD12D	P	5	1.2V core power
47	TXC5/REFCLKI5/GTXC5	I/O	5	<b><u>Port 5 Switch GMAC5 Clock Pin:</u></b> <b><u>MII:</u></b> 2.5/25MHz clock, PHY mode is output, MAC mode is input. <b><u>RMII:</u></b> Input for receiving 50MHz in normal mode. <b><u>RGMII:</u></b> Input 125MHz clock with falling and rising edge to latch data for the transmit.
48	RXC5/GRXC5	I/O	5	<b><u>Port 5 Switch GMAC5 Clock Pin:</u></b> <b><u>MII:</u></b> 2.5/25MHz clock, PHY mode is output, MAC mode is input. <b><u>RMII:</u></b> Output 50MHz reference clock for the receiving/transmit in the clock mode. <b><u>RGMII:</u></b> Output 125MHz clock with falling and rising edge to latch data for the receiving.
49	RXD5_0	IPD/O	5	<b><u>RGMII/MII/RMII:</u></b> Port 5 switch receive bit [0]
50	RXD5_1	IPD/O	5	<b><u>RGMII/MII/RMII:</u></b> Port 5 switch receive bit [1]
51	GNDD	GND		Digital ground
52	VDDIO	P		3.3V, 2.5V, or 1.8V digital VDD for digital I/O circuitry.
53	RXD5_2	IPD/O	5	<b><u>RGMII/MII:</u></b> Port 5 switch receive bit [2] <b><u>RMII:</u></b> No connection
54	RXD5_3	IPD/O	5	<b><u>RGMII/MII:</u></b> Port 5 switch receive bit [3] <b><u>RMII:</u></b> No connection
55	RXDV5/CRSDV5/RXD5_CTL	IPD/O	5	<b><u>MII:</u></b> RXDV5 is for Port 5 switch MII receive data valid. <b><u>RMII:</u></b> CRSDV5 is for Port 5 RMII carrier sense/receive data valid output. <b><u>RGMII:</u></b> RXD5_CTL is for Port 5 RGMII receive data control.
56	RXER5	IPD/O	5	<b><u>MII:</u></b> Port 5 switch receive error. <b><u>RGMII/RMII:</u></b> No connection.

**Pin Description (Continued)**

Pin Number	Pin Name	Type <sup>(1)</sup>	Port	Pin Function <sup>(2)</sup>
57	CRS5	IPD/O	5	<b>MII:</b> Port 5 switch MII modes carrier sense. <b>RGMI/RMII:</b> No connection.
58	COL5	IPD/O	5	<b>MII:</b> Port 5 Switch MII collision detect. <b>RGMI/RMII:</b> No connection.
59	REFCLKO	IPU/O		25MHz clock output (Option) Controlled by the strap pin LED2_0. Default is enabled; it is better to disable it if not using it.
60	PME_N	I/O		<b>Power Management Event</b> This output signal indicates that a wake-on-LAN event has been detected as a result of a wake-up frame detection. The KSZ8775CLX is requesting the system to wake up from low power mode. Its assertion polarity is programmable with the default polarity set to active low.
61	GNDD	GND		Digital ground
62	TXEN4	IPD	4	<b>RMII:</b> Port 4 switch SW4-RMII transmit enable.
63	LED2_1	IPU/O	2	<b>Port 2 LED Indicator 1.</b> See global Register 11 bits [5:4] for details. Strap option: Port 5 MII and RMII modes select When Port 5 is MII mode: PU = MAC mode. PD = PHY mode. When Port 5 is RMII mode: PU = Clock mode in RMII, using 25MHz OSC clock and provide 50MHz RMII clock from pin RXC5. PD = Normal mode in RMII, the TXC5/REFCLKI5 pin on the Port 5 RMII will receive an external 50MHz clock <b>Note:</b> Port 5 also can use either an internal or external clock in RMII mode based on this strap pin or the setting of the Register 86 (0x56) bit[7].
64	LED2_0	IPU/O	2	<b>Port 2 LED Indicator 0.</b> See global Register 11 bits [5:4] for details. Strap option: REFCLKO enable PU = REFCLK_O (25MHz) is enabled. (default) PD = REFCLK_O is disabled <b>Note:</b> It is better to disable this 25MHz clock if not providing an extra 25MHz clock for system.

**Pin Description (Continued)**

Pin Number	Pin Name	Type <sup>(1)</sup>	Port	Pin Function <sup>(2)</sup>
65	LED1_1	IPU/O	1	<p><b><u>Port 1 LED Indicator 1.</u></b> See global Register 11 bits [5:4] for details. Strap option: PLL clock source select PU = Still use 25MHz clock from XI/XO pins even though it is in Port 5 RMII normal mode. PD = Use external clock from TXC5 in Port 5 RMII normal mode. <b>Note:</b> If received clock in Port 5 RMII normal mode has too much clock jitter, you can still select the 25MHz crystal/oscillator as the switch's clock source.</p>
66	LED1_0	IPU/O	1	<p><b><u>Port 1 LED Indicator 0.</u></b> See global Register 11 bits [5:4] for details. Strap option: Speed select in Port 5 RGMII PU = 1Gbps in RGMII.(default) PD = 10/100Mbps in RGMII. <b>Note:</b> Programmable through internal registers also.</p>
67	SPIQ	IPD/O	All	<p><b><u>SPI Serial Data Output in SPI Slave Mode.</u></b> Strap option: Serial bus configuration PD = SPI slave mode. PU = MDC/MDIO mode. <b>Note:</b> An external pull-up or pull-down resistor is required.</p>
68	SCL_MDC	IPU	All	<p><b><u>Clock Input for SPI or MDC/MDIO Interface.</u></b> 1. Input clock up to 50MHz in SPI slave mode. 2. Input clock up to 25MHz in MDC/MDIO for MIIM access.</p>
69	SDA_MDIO	IPU/O	All	<p><b><u>Data for SPI or MDC/MDIO Interface.</u></b> 1. Serial data input in SPI slave mode. 2. MDC/MDIO interface data input/output.</p>
70	SPIS_N	IPU	All	<p><b><u>SPI Interface Chip Select.</u></b> When SPIS_N is high, the KSZ8775CLX is deselected and SPIQ is held in the high impedance state. A high-to-low transition initiates the SPI data transfer. This pin is active low.</p>
71	VDDIO	P		3.3V, 2.5V, or 1.8V digital V <sub>DD</sub> for digital I/O circuitry.
72	GNDD	GND		Digital ground.
73	RST_N	IPU		<p><b><u>Reset</u></b> This active low signal resets the hardware in the device. See the timing requirements in the <i>Timing Diagram</i> section.</p>
74	VDD12D	P		1.2V core power

**Pin Description (Continued)**

Pin Number	Pin Name	Type <sup>(1)</sup>	Port	Pin Function <sup>(2)</sup>
75	ATST	NC		No connect. Factory test pin.
76	VDDAT	P		3.3V analog power
77	ISET			<b><u>Transmit Output Current Set</u></b> This pin configures the physical transmit output current. It should be connected to GND thru a 12.4kΩ 1% resistor.
78	GNDA	GND		Analog ground
79	XI	I		<b><u>Crystal Clock Input/Oscillator Input</u></b> When using a 25MHz crystal, this input is connected to one end of the crystal circuit. When using a 3.3V oscillator, this is the input from the oscillator. The crystal or oscillator should have a tolerance of ±50ppm.
80	XO	O		<b><u>Crystal Clock Output</u></b> When using a 25MHz crystal, this output is connected to one end of the crystal circuit.



## Strap-In Options

The KSZ8775CLX can function as a managed switch and utilizes strap-in pins to configure the device for different modes. The strap-in option pins are configured by using external pull-up/down resistors to create a high or low state on the pins which are sampled during the power down reset or warm reset. The functions are described in the table below.

Pin Number	Pin Name	PU/PD <sup>(3)</sup>	Description
43	RXD4_0	IPD/O	<p><b><u>Clock or Normal Mode Select in Port 4 RMII</u></b></p> <p><b><u>Strap Option:</u></b>            PU = Clock mode in RMII, using 25MHz OSC clock and provide 50MHz RMII clock from pin RXC4.            PD = Normal mode in RMII, the TXC4/REFCLKI4 pin on the Port 5 RMII will receive an external 50MHz clock</p> <p><b>Note:</b> Port 4 also can use either an internal or external clock in RMII mode based on this strap pin or the setting of the Register 70 (0x46) bit[7]. An external pull-up/down resistor is requested.</p>
64	LED2_0	IPU/O	<p><b><u>REFCLKO Enable</u></b></p> <p><b><u>Strap Option:</u></b>            PU = REFCLK_O (25MHz) is enabled.            PD = REFCLK_O is disabled</p>
63	LED2_1	IPU/O	<p><b><u>Port 5 MII and RMII Modes Select</u></b></p> <p><b><u>Strap Option:</u></b>            When Port 5 is MII mode:            PU = MAC mode.            PD = PHY mode.            When Port 5 is RMII mode:            PU = Clock mode in RMII, using 25MHz OSC clock and provide 50MHz RMII clock from pin RXC5.            PD = Normal mode in RMII, the TXC5/REFCLKI5 pin on the Port 5 RMII will receive an external 50MHz clock</p> <p><b>Note:</b> Port 5 also can use either an internal or external clock in RMII mode based on this strap pin or the setting of the Register 86 (0x56) bit[7].</p>
25,27	LED3[1,0]	IPU/O	<p><b><u>Switch Port 5 GMAC5 Interface Mode Select</u></b></p> <p><b><u>Strap Option:</u></b>            00 = MII for SW5-MII            01 = RMII for SW5-RMII            10 = Reserved            11 = RGMII for SW5-RGMII (default)</p>

**Note:**

3. IPD/O = Input with internal pull-down during reset, output pin otherwise.  
 IPU/O = Input with internal pull-up during reset, output pin otherwise.

**Strap-In Options (Continued)**

Pin Number	Pin Name	PU/PD <sup>(3)</sup>	Description
66	LED1_0	IPU/O	<p><b>Port 5 Gigabit Select</b>  <b>Strap Option:</b>            PU = 1Gbps in RGMII (default).            PD = 10/100Mbps in RGMII.  <b>Note:</b> Also programmable through internal register.</p>
65	LED1_1	IPU/O	<p><b>PLL Clock Source Select</b>  <b>Strap Option:</b>            PD = Still uses 25MHz clock from XI/XO pin even though it is in Port 5 RMII normal mode (default).            PU = Uses external clock from TXC5 pin in Port 5 RMII normal mode.  <b>Note:</b> If received clock in Port 5 RMII normal mode has too much clock jitter, you still can select the 25MHz crystal/oscillator as the switch's clock source.</p>
67	SPIQ	IPD/O	<p><b>Serial Bus Configuration</b>  <b>Strap Option:</b>            PD = SPI slave mode.            PU = MDC/MDIO mode.  <b>Note:</b> An external pull-up or pull-down resistor is required.</p>

## Introduction

The KSZ8775CLX contains three 10/100 physical layer transceivers, four media access control (MAC) units, and one Gigabit media access control (GMAC) unit with an integrated Layer 2-managed switch. The device runs in two modes. The first mode is as a three-port standalone switch. The second is as a five-port switch where the fifth port is provided through a Gigabit media independent interface that supports RGMII, MII, and RMII. This is useful for implementing an integrated broadband router.

The KSZ8775CLX has the flexibility to reside in a managed mode. In a managed mode, a host processor has complete control of the KSZ8775CLX via the SPI bus or the MDC/MDIO interface.

On the media side, the KSZ8775CLX supports IEEE 802.3 10BASE-T/100BASE-TX on all copper ports with Auto-MDI/MDI-X. The KSZ8775CLX can be used as a fully managed five-port switch or hooked up to a microprocessor via its SW-RGMII/MII/RMII interfaces to allow for integrating into a variety of environments.

Physical signal transmission and reception are enhanced through the use of patented analog circuitry and DSP technology that makes the design more efficient, allows for reduced power consumption, and smaller die size.

Major enhancements from the KSZ8995 and KS8895 to the KSZ8775CLX include high speed host interface options such as the RGMII interface, power saving features such as IEEE 802.1az energy-efficient Ethernet (EEE), MLD snooping, wake-on-LAN (WoL), port-based ACL filtering for port security, enhanced QoS priority, rapid spanning tree, IGMP snooping, port mirroring support, and flexible rate limiting.

## Functional Overview: Physical Layer (PHY)

### 100BASE-TX Transmit

The 100BASE-TX transmit function performs parallel-to-serial conversion, 4B/5B coding, scrambling, NRZ-to-NRZI conversion, MLT3 encoding and transmission. The circuit starts with a parallel-to-serial conversion, which converts the MII data from the MAC into a 125MHz serial bit stream. The data and control stream is then converted into 4B/5B coding followed by a scrambler. The serialized data is further converted from NRZ-to-NRZI format, and then transmitted in MLT3 current output. The output current is set by an external 1% 12.4k $\Omega$  resistor for the 1:1 transformer ratio. It has a typical rise/fall time of 4ns and complies with the ANSI TP-PMD standard regarding amplitude balance, overshoot, and timing jitter. The wave-shaped 10BASE-T output is also incorporated into the 100BASE-TX transmitter.

### 100BASE-TX Receive

The 100BASE-TX receiver function performs adaptive equalization, DC restoration, MLT3-to-NRZI conversion, data and clock recovery, NRZI-to-NRZ conversion, descrambling, 4B/5B decoding, and serial-to-parallel conversion. The receiving side starts with the equalization filter to compensate for intersymbol interference (ISI) over the twisted pair cable. Since the amplitude loss and phase distortion is a function of the length of the cable, the equalizer has to adjust its characteristics to optimize the performance. In this design, the variable equalizer will make an initial estimation based on comparisons of incoming signal strength against some known cable characteristics, then tunes itself for optimization. This is an ongoing process and can self-adjust against environmental changes such as temperature variations.

The equalized signal then goes through a DC restoration and data conversion block. The DC restoration circuit is used to compensate for the effect of baseline wander and improve the dynamic range. The differential data conversion circuit converts the MLT3 format back to NRZI. The slicing threshold is also adaptive.

The clock recovery circuit extracts the 125MHz clock from the edges of the NRZI signal. This recovered clock is then used to convert the NRZI signal into the NRZ format. The signal is then sent through the de-scrambler followed by the 4B/5B decoder. Finally, the NRZ serial data is converted to the MII format and provided as the input data to the MAC.

### PLL Clock Synthesizer

The KSZ8775CLX generates 125MHz, 83MHz, 41MHz, 25MHz, and 10MHz clocks for system timing. Internal clocks are generated from an external 25MHz crystal or oscillator.

### Scrambler/Descrambler (10BASE-TX Only)

The purpose of the scrambler is to spread the power spectrum of the signal in order to reduce EMI and baseline wander. The data is scrambled through the use of an 11-bit wide linear feedback shift register (LFSR). This can generate a 2047-bit non-repetitive sequence. The receiver will then descramble the incoming data stream with the same sequence at the transmitter.

### 10BASE-T Transmit

The 10BASE-T output driver is incorporated into the 100BASE-T driver to allow transmission with the same magnetics. They are internally wave-shaped and pre-emphasized into outputs with a typical 2.3V amplitude. The harmonic contents are at least 27dB below the fundamental when driven by an all-ones Manchester-encoded signal.

### 10BASE-T Receive

On the receive side, input buffers and level-detecting squelch circuits are employed. A differential input receiver circuit and a PLL perform the decoding function. The Manchester-encoded data stream is separated into a clock signal and NRZ data. A squelch circuit rejects signals with levels less than 400mV or with short pulse-widths in order to prevent noises at the RXP or RXM input from falsely triggering the decoder. When the input exceeds the squelch limit, the PLL locks onto the incoming signal and the KSZ8775CLX decodes a data frame. The receiver clock is maintained active during idle periods in between data reception.

### MDI/MDI-X Auto Crossover

To eliminate the need for crossover cables between similar devices, the KSZ8775CLX supports HP Auto-MDI/MDI-X and IEEE 802.3u standard MDI/MDI-X auto crossover. HP Auto-MDI/MDI-X is the default.

The auto-sense function detects remote transmit and receive pairs and correctly assigns transmit and receive pairs for the KSZ8775CLX device. This feature is extremely useful when end users are unaware of cable types, and also, saves on an additional uplink configuration connection. The auto-crossover feature can be disabled through the port control registers or MIIM PHY registers. The IEEE 802.3u standard MDI and MDI-X definitions are in the table below.

**Table 1. MDI/MDI-X Pin Definitions**

MDI		MDI-X	
RJ-45 Pins	Signals	RJ-45 Pins	Signals
1	TD+	1	RD+
2	TD-	2	RD-
3	RD+	3	TD+
6	RD-	6	TD-

**Straight Cable**

A straight cable connects an MDI device to an MDI-X device or an MDI-X device to an MDI device. The following diagram depicts a typical straight cable connection between a NIC (MDI) and a switch or hub (MDI-X).

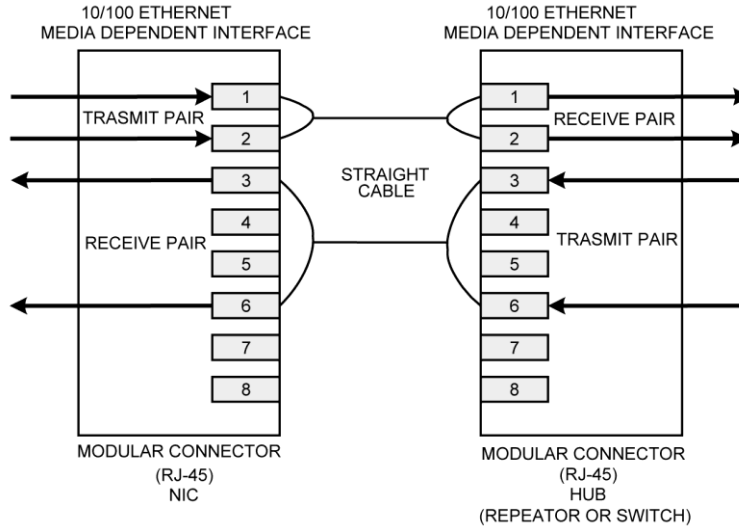

**Figure 3. Typical Straight Cable Connection**

**Crossover Cable**

A crossover cable connects an MDI device to another MDI device or an MDI-X device to another MDI-X device. The following diagram shows a typical crossover cable connection between two switches or hubs (two MDI-X devices).

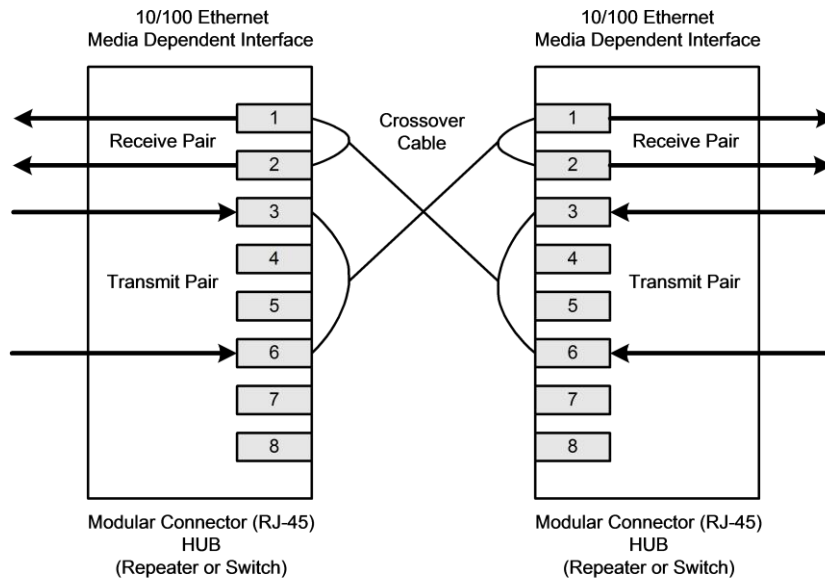

**Figure 4. Typical Crossover Cable Connection**

### Auto-Negotiation

The KSZ8775CLX conforms to the auto-negotiation protocol as described by the IEEE 802.3 committee. Auto-negotiation allows unshielded twisted pair (UTP) link partners to select the highest common mode of operation. Link partners advertise their capabilities to each other and then compare their own capabilities with those they received from their link partners. The highest speed and duplex setting that is common to the two link partners is selected as the mode of operation. Auto-negotiation is supported only for the copper ports.

The following list shows the speed and duplex operation mode from highest to lowest.

- Highest: 100Base-TX, full-duplex
- High: 100Base-TX, half-duplex
- Low: 10Base-T, full-duplex
- Lowest: 10Base-T, half-duplex

If auto-negotiation is not supported or the KSZ8775CLX link partner is forced to bypass auto-negotiation, the KSZ8775CLX sets its operating mode by observing the signal at its receiver. This is known as parallel detection and allows the KSZ8775CLX to establish link by listening for a fixed signal protocol in the absence of auto-negotiation advertisement protocol. The auto-negotiation link up process is shown in the following flow chart.

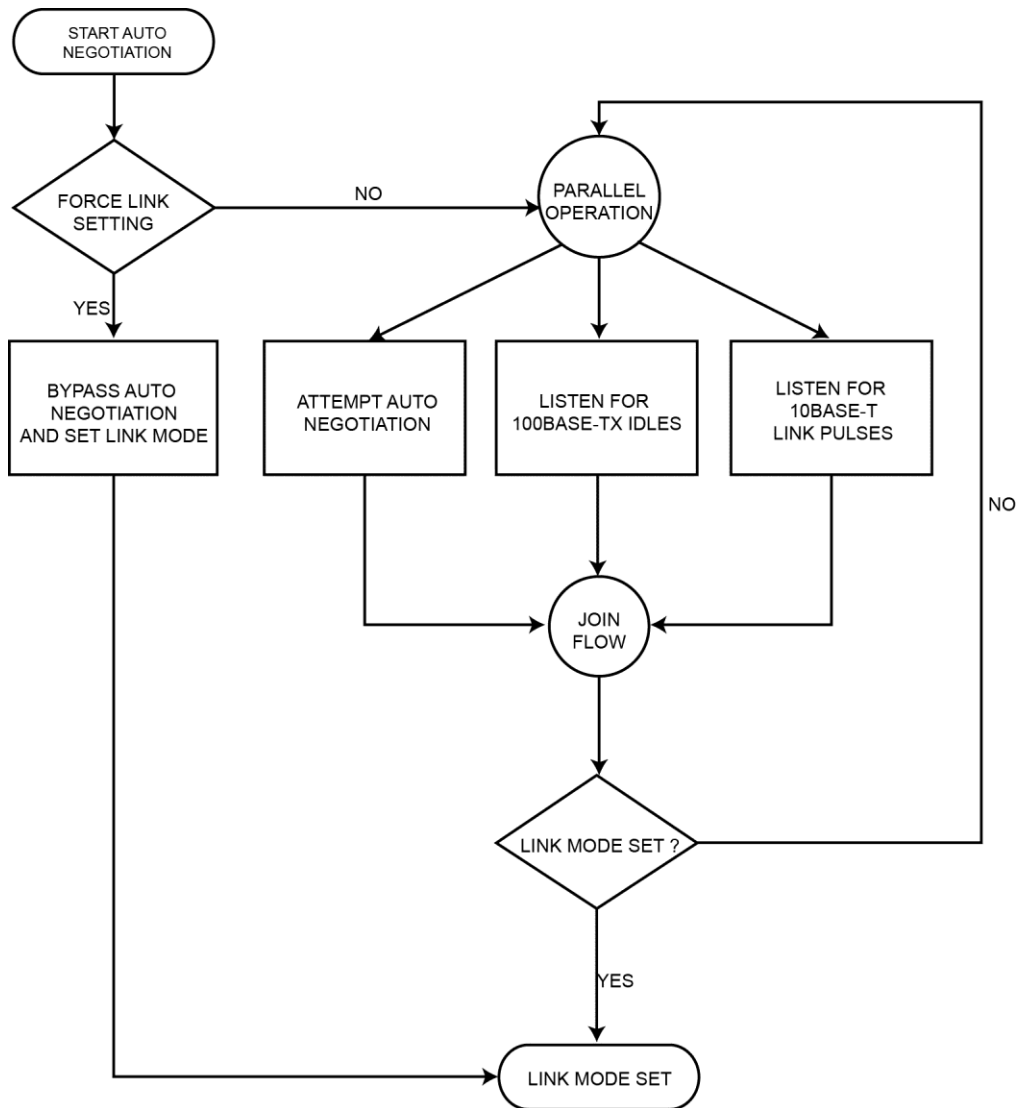

Figure 5. Auto-Negotiation and Parallel Operation

## LinkMD<sup>®</sup> Cable Diagnostics

The LinkMD<sup>®</sup> feature utilizes time domain reflectometry (TDR) to analyze the cabling plant for common cabling problems such as open circuits, short circuits, and impedance mismatches.

LinkMD works by sending a pulse of known amplitude and duration down the MDI and MDI-X pairs and then analyzes the shape of the reflected signal. Timing the pulse duration gives an indication of the distance to the cabling fault with maximum distance of 200m and accuracy of  $\pm 2$ m. Internal circuitry displays the TDR information in a user-readable digital format.

Please note that cable diagnostics are only valid for copper connections.

### Access

LinkMD is initiated by accessing the PHY's special control/status Registers {26, 42, 58} and the LinkMD result Registers {27, 43, 59} for Ports 1, 2, and 3 respectively and in conjunction with the Port control 10 Register for Ports 1, 2, and 3 respectively to disable Auto-MDI/MDI-X.

Alternatively, the MIIM PHY Registers 0 and 1d can also be used for LinkMD access.

### Usage

The following is a sample procedure for using LinkMD with Registers {26, 27, 29} on Port 1.

1. Disable Auto-MDI/MDI-X by writing a '1' to Register 29, bit [2] to enable manual control over the differential pair used to transmit the LinkMD pulse.
2. Start cable diagnostic test by writing a '1' to Register 26, bit [4]. This enable bit is self-clearing.
3. Wait (poll) for Register 26, bit [4] to return a '0', and indicating cable diagnostic test is completed.
4. Read cable diagnostic test results in Register 26, bits [6:5]. The results are as follows:
  - 00 = normal condition (valid test)
  - 01 = open condition detected in cable (valid test)
  - 10 = short condition detected in cable (valid test)
  - 11 = cable diagnostic test failed (invalid test)

The '11' case, invalid test, occurs when the KSZ8775CLX is unable to shut down the link partner. In this instance, the test is not run because it would be impossible for the KSZ8775CLX to determine if the detected signal is a reflection of the signal generated or a signal from another source.

5. Get distance to fault by concatenating Register 26, bit [0] and Register 27, bits [7:0] and multiplying the result by a constant of 0.4. The distance to the cable fault can be determined by the following formula:

$$D (\text{distance to cable fault meter}) = 0.4 \times (\text{Register 26, bit [0], Register 27, bits [7:0]})$$

D (distance to cable fault) is expressed in meters.

Concatenated value of Registers 26 bit [0] and 27 bits [7:0] should be converted to decimal before multiplying by 0.4.

The constant (0.4) may be calibrated for different cabling conditions, including cables with a velocity of propagation that varies significantly from the norm.

For Port 2, Port 3, and using the MIIM PHY registers, LinkMD usage is similar.

**A LinkMD® Example**

The following is a sample procedure for using LinkMD® on Port 1, Port 2, and Port 3.

```
//Disable Auto-MDI/MDI-X and force to MDI-X mode
//'w' is WRITE the register. 'r' is READ register below
w 1d 04
w 2d 04
w 3d 04
//Set internal registers temporary by indirect registers, adjust for LinkMD
w 6e a0
w 6f 4d
w a0 80
//Enable LinkMD testing with fault cable for Port 1, Port 2, and Port 3
w 1a 10
w 2a 10
w 3a 10
//Wait until Port Register Control 8 bit [4] returns a '0' (self-clear)
//Diagnosis results
r 1a
r 1b
r 2a
r 2b
r 3a
r 3b
//For example on Port 1, the result analysis based on the values of the register 0x1a and 0x1b
//The register 0x1a bits [6-5] are for the open or the short detection.
//The register 0x1a bit [0] + the register 0x1b bits [7-0] = CDT_Fault_Count [8-0]
//The distance to fault is about 0.4 x (CDT_Fault_Count [8-0])
```

**On-Chip Termination and Internal Biasing**

The KSZ8775CLX reduces the board cost and simplifies the board layout by using on-chip termination resistors for all ports and RX/TX differential pairs without external termination resistors. The combination of the on-chip termination and the internal biasing will save more PCB space and power consumption in system, compared with using external biasing and termination resistors for multiple ports' switches because the transformers do not consume power anymore. The center taps of the transformer should not need to be tied to the analog power.



## Functional Overview: Media Access Controller (MAC)

### Media Access Controller Operation

The KSZ8775CLX strictly abides by IEEE 802.3 standards to maximize compatibility.

### Inter-Packet Gap (IPG)

If a frame is successfully transmitted, the 96-bit time IPG is measured between the two consecutive MTXEN. If the current packet is experiencing collision, the 96-bit time IPG is measured from MCRS and the next MTXEN.

### Backoff Algorithm

The KSZ8775CLX implements the IEEE 802.3 standard binary exponential backoff algorithm and optional “aggressive mode” backoff. After 16 collisions, the packet will be optionally dropped depending on the chip configuration in Register 3.

### Late Collision

If a transmit packet experiences collisions after 512-bit times of the transmission, the packet will be dropped.

### Illegal Frames

The KSZ8775CLX discards frames less than 64 bytes and can be programmed to accept frames up to 1536 bytes in Register 4. For special applications, the KSZ8775CLX can also be programmed to accept frames up to 2k bytes in Register 3 bit [6]. Because the KSZ8775CLX supports VLAN tags, the maximum sizing is adjusted when these tags are present.

### Flow Control

The KSZ8775CLX supports standard IEEE 802.3x flow control frames on both transmit and receive sides.

On the receive side, if the KSZ8775CLX receives a pause control frame, the KSZ8775CLX will not transmit the next normal frame until the timer, specified in the pause control frame, expires. If another pause frame is received before the current timer expires, the timer will be updated with the new value in the second pause frame. During this period (being flow-controlled), only flow control packets from the KSZ8775CLX will be transmitted.

On the transmit side, the KSZ8775CLX has intelligent and efficient ways to determine when to invoke flow control. The flow control is based on availability of the system resources, including available buffers, available transmit queues, and available receive queues.

The KSZ8775CLX flow controls a port that has just received a packet if the destination port resource is busy. The KSZ8775CLX issues a flow control frame (XOFF) containing the maximum pause time defined in the IEEE 802.3x standard. Once the resource is freed up, the KSZ8775CLX sends out the other flow control frame (XON) with zero pause time to turn off the flow control (turn on transmission to the port). A hysteresis feature is also provided to prevent over-activation and deactivation of the flow control mechanism.

The KSZ8775CLX flow controls all ports if the receive queue becomes full.

### **Half-Duplex Back Pressure**

The KSZ8775CLX also provides a half-duplex back pressure option (this is not in IEEE 802.3 standards). The activation and deactivation conditions are the same as the ones given for full-duplex mode. If back pressure is required, then the KSZ8775CLX sends preambles to defer the other station's transmission (carrier sense deference). To avoid jabber and excessive deference as defined in IEEE 802.3 standards, after a certain period of time, the KSZ8775CLX discontinues carrier sense but raises it quickly after it drops packets to inhibit other transmissions. This short silent time (no carrier sense) prevents other stations from sending out packets and keeps other stations in a carrier-sense-deferred state. If the port has packets to send during a back pressure situation, then the carrier-sense-type back pressure is interrupted and those packets are transmitted instead. If there are no more packets to send, carrier-sense-type back pressure becomes active again until switch resources are free. If a collision occurs, the binary exponential backoff algorithm is skipped and carrier sense is generated immediately, reducing the chance of further colliding and maintaining carrier sense to prevent reception of packets. To ensure no packet loss in 10BASE-T or 100BASE-TX half-duplex modes, the user must enable the following:

- Aggressive backoff (Register 3, bit [0])
- No excessive collision drop (Register 4, bit [3])
- Back pressure (Register 4, bit [5])

These bits are not set as the default because this is not the IEEE standard.

### **Broadcast Storm Protection**

The KSZ8775CLX has an intelligent option to protect the switch system from receiving too many broadcast packets. Broadcast packets are normally forwarded to all ports except the source port and thus use too many switch resources (bandwidth and available space in transmit queues). The KSZ8775CLX has the option to include multicast packets for storm control. The broadcast storm rate parameters are programmed globally and can be enabled or disabled on a per port basis. The rate is based on a 50ms (0.05s) interval for 100BT and a 500ms (0.5s) interval for 10BT. At the beginning of each interval, the counter is cleared to zero and the rate limit mechanism starts to count the number of bytes during the interval. The rate definition is described in Registers 6 and 7. The default setting for Registers 6 and 7 is 0x4A (74 decimal). This is equal to a rate of 1%, calculated as follows:

$$148,80 \text{ frames/sec} \times 50\text{ms} (0.05\text{s})/\text{interval} \times 1\% = 74 \text{ frames/interval (approx.)} = 0x4A$$

## Functional Overview: Switch Core

The internal look-up table stores MAC addresses and their associated information. It contains a 1k unicast address table plus switching information. The KSZ8775CLX is guaranteed to learn 1k addresses and distinguishes itself from a hash-based look-up table, which, depending on the operating environment and probabilities, may not guarantee the absolute number of addresses it can learn.

### Learning

The internal look-up engine updates its table with a new entry if the following conditions are met:

- The received packet's source address (SA) does not exist in the look-up table.
- The received packet is good; the packet has no receiving errors and is of legal length.

The look-up engine inserts the qualified SA into the table, along with the port number and time stamp. If the table is full, the last entry of the table is deleted first to make room for the new entry.

### Migration

The internal look-up engine also monitors whether a station is moved. If this occurs, it updates the table accordingly. Migration happens when the following conditions are met:

- The received packet's SA is in the table, but the associated source port information is different.
- The received packet is good; the packet has no receiving errors and is of legal length.

The look-up engine will update the existing record in the table with the new source port information.

### Aging

The look-up engine will update the time stamp information of a record whenever the corresponding SA appears. The time stamp is used in the aging process. If a record is not updated for a period of time, the look-up engine will remove the record from the table. The look-up engine constantly performs the aging process and will continuously remove aging records. The aging period is  $300 \pm 75$  seconds. This feature can be enabled or disabled through Register 3 bit [2].

### Forwarding

The KSZ8775CLX will forward packets using an algorithm that is depicted in the following flowcharts. The next figure shows stage one of the forwarding algorithm where the search engine looks up the VLAN ID, static table, and dynamic table for the destination address, and then comes up with port to forward 1 (PTF1). PTF1 is then further modified by the spanning tree, IGMP snooping, port mirroring, and port VLAN processes and authentication to come up with port to forward 2 (PTF2), as shown in the figure below. The authentication and ACL have highest priority in the forwarding process, ACL result will overwrite the result of the forwarding process. This is where the packets will be sent.

The KSZ8775CLX will not forward the following packets:

- Error packets: These include framing errors, frame check sequence (FCS) errors, alignment errors, and illegal size packet errors.
- IEEE 802.3x PAUSE frames: KSZ8775CLX intercepts these packets and performs full-duplex flow control accordingly.
- Local packets: Based on destination address (DA) lookup, if the destination port from the look-up table matches the port from which the packet originated, the packet is defined as local.

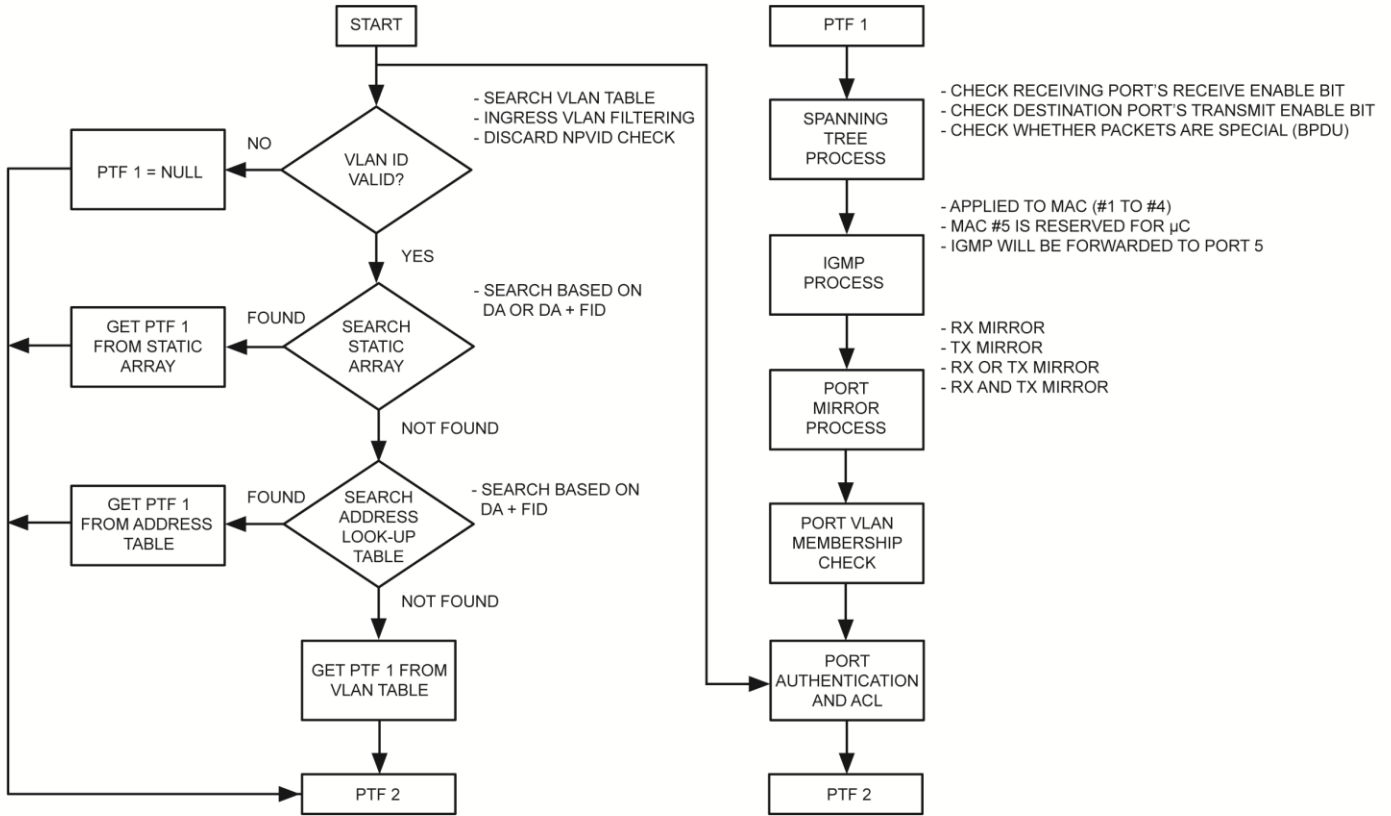

Figure 6. Destination Address Look-up and Resolution Flow Chart

**Switching Engine**

The KSZ8775CLX features a high-performance switching engine to move data to and from the MAC’s packet buffers. It operates in store and forward modes, while the efficient switching mechanism reduces overall latency. The KSZ8775CLX has a 64kb internal frame buffer. This resource is shared between all five ports. There are a total of 512 buffers available. Each buffer is sized at 128 bytes.

## Functional Overview: Power

The KSZ8775CLX device requires 3.3V analog power. An external 1.2V LDO provides the necessary 1.2V to power the analog and digital logic cores. The various I/Os can be operated at 1.8V, 2.5V, and 3.3V. The table below illustrates the various voltage options and requirements of the device.

Power Signal Name	Device Pin	Requirement
VDDAT	4, 14, 76	3.3V input power to the analog blocks of transceiver in the device.
VDDIO	36, 52, 71	Choice of 1.8V or 2.5V or 3.3V for the I/O circuits. These input power pins power the I/O circuitry of the device.
VDD12A	3	1.2V core power. Filtered 1.2V input voltage. These pins feed 1.2V to power the internal analog and digital cores.
VDD12D	28, 46, 74	
GNDA	5, 21, 78	Analog ground.
GNDD	29, 35, 41, 51, 61, 72	Digital ground.

## Functional Overview: Power Management

The KSZ8775CLX supports enhanced power management in a low power state, with energy detection to ensure low power dissipation during device idle periods. There are three operation modes under the power management function which are controlled by the Register 14 bits [4:3] and the Port Control 10 Register bit [3] as shown below:

- Register 14 bits [4:3] = 00 normal operation mode
- Register 14 bits [4:3] = 01 energy detect mode
- Register 14 bits [4:3] = 10 soft power-down mode
- Register 14 bits [4:3] = 11 reserved

The Port Control 10 Register 29, 45, 61 bit [3] = 1 are for the port-based power-down mode.

Table 2 indicates all internal function block statuses under four different power management operation modes.

**Table 2. Internal Function Block Status**

KSZ8775CLX Function Blocks	Power Management Operation Modes		
	Normal Mode	Energy Detect Mode	Soft Power-Down Mode
Internal PLL Clock	Enabled	Disabled	Disabled
TX/RX PHY	Enabled	Energy detect at RX	Disabled
MAC	Enabled	Disabled	Disabled
Host Interface	Enabled	Disabled	Disabled

### Normal Operation Mode

This is the default setting bits [4:3] = 00 in Register 14 after chip power-up or hardware reset. When KSZ8775CLX is in normal operation mode, all PLL clocks are running, PHY and MAC are on, and the host interface is ready for CPU read or write.

During normal operation mode, the host CPU can set the bits [4:3] in Register 14 to change the current normal operation mode to any one of the other three power management operation modes.

### Energy Detect Mode

Energy detect mode provides a mechanism to save more power than in the normal operation mode when the KSZ8775CLX port is not connected to an active link partner. In this mode, the device will save more power when the

cables are unplugged. If the cable is not plugged in, the device can automatically enter a low power state—the energy detect mode. In this mode, the device will keep transmitting 120ns-wide pulses at a rate of 1 pulse per second. Once activity resumes due to plugging in a cable or an attempt by the far end to establish a link, the device can automatically power up to normal power state in energy detect mode.

Energy detect mode consists of the normal power state and low power state. While in low power state, the device reduces power consumption by disabling all circuitry except the energy detect circuitry of the receiver. The energy detect mode is entered by setting bits [4:3] = 01 in Register 14. When the KSZ8775CLX is in this mode, it will monitor the cable energy. If there is no energy on the cable for a time longer than the pre-configured value at bits [7:0] go-sleep time in Register 15, then the KSZ8775CLX will go into low power state. When the KSZ8775CLX is in low power state, it will keep monitoring the cable energy. Once the energy is detected from the cable, the device will enter normal power state. When the device is at normal power state, it is able to transmit or receive packet from the cable.

**Soft Power-Down Mode**

The soft power-down mode is entered by setting bits [4:3] = 10 in Register 14. When the KSZ8775CLX is in this mode, all PLL clocks are disabled, also all of the PHYs and MACs are off. Any dummy host access will wake-up this device from current soft power-down mode to normal operation mode and internal reset will be issued to make all internal registers go to the default values.

**Port-Based Power-Down Mode**

In addition, the KSZ8775CLX features a per-port power-down mode. To save power, a PHY port that is not in use can be powered down via the Port Control 10 Register bit [3] or MIIM PHY Register 0 bit [11].

**Energy-Efficient Ethernet (EEE)**

Along with supporting different power saving modes, the KSZ8775CLX extends its green functionality by supporting EEE features defined in IEEE P802.3az/D2.3, March 2010. Both 10Base-T and 100Base-TX EEE functions are supported in KSZ8775CLX. In 100Base-TX, the EEE operation is asymmetric on the same link, which means one direction could be in low power idle (LPI) state while another direction could handle packet transfer activity. Different from other types of power saving modes, EEE is able to maintain the link while conserving power. Based on IEEE specification, the energy saving from EEE is done at the PHY level. KSZ8775CLX reduces the power consumption not only at PHY level but also at MAC and switch level by shutting down the unused clocks as much as possible when the device is in low power idle phase.

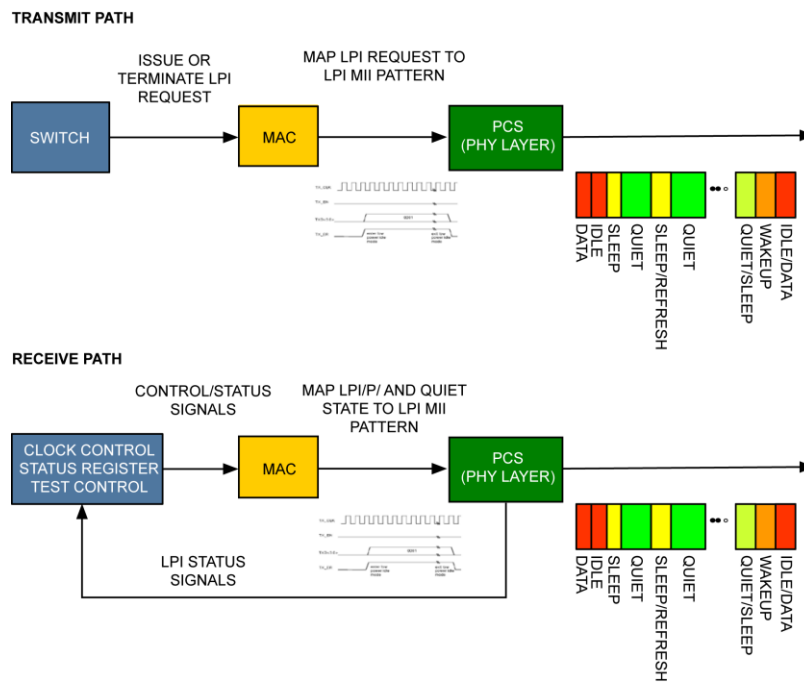

Figure 7. EEE Transmit and Receive Signaling Paths

The KSZ8775CLX supports the IEEE 802.3az energy-efficient Ethernet standard for both 10 and 100Mbps interfaces. The EEE capability combines switch, MAC, and PHY to support operation in low power idle (LPI) mode. When the LPI mode is enabled, systems on both sides of the link can save power during periods of low link utilization.

EEE implementation provides a protocol to coordinate transitions to or from lower power consumption without changing the link status and without dropping or corrupting frames. The transition time into and out of the lower power consumption is kept small enough to be transparent to upper layer protocols and applications. EEE specifies the means to exchange capabilities between link partners to determine whether EEE is supported and to select the best set of parameters common to both sides.

Besides supporting the 100BASE-TX PHY EEE, KSZ8775CLX also supports 10BASE-T with reduced transmit amplitude requirements for 10Mbps mode to allow a reduction in power consumption.

### ***LPI Signaling***

Low power idle signaling allows the switch to indicate to the PHY, and to the link partner, that a break in the data stream is expected. The switch can use this information to enter power-saving modes that require additional time to resume normal operation. LPI signaling also informs the switch when the link partner has sent such an indication. The definition of LPI signaling uses the MAC for simplified full-duplex operation with carrier sense deferral. This provides full-duplex operation but uses the carrier sense signal to defer transmission when the PHY is in the LPI mode.

The decision on when to signal LPI (LPI request) to the link partner is made by the switch and communicated to the PHY through the MAC MII interface. The switch is also informed when the link partner is signaling LPI and indicating LPI activation (LPI indication) on the MAC interface. The conditions under which the switch decides to send LPI and what actions are taken by the switch when it receives LPI from the link partner, are specified in the implementation section.

### ***LPI Assertion***

Without LPI assertion, the normal traffic transition continues on the MII interface. As soon as an LPI request is asserted, the LPI assert function starts to transmit the "Assert LPI" encoding on the MII and stops the MAC from transmitting normal traffic. Once the LPI request is de-asserted, the LPI assert function starts to transmit the normal inter-frame encoding on the MII again. After a delay, the MAC is allowed to start transmitting again. This delay is provided to allow the link partner to prepare for normal operation. [Figure 8](#) illustrates the EEE LPI between two active data idles.

### ***LPI Detection***

In the absence of "Assert LPI" encoding on the receive MII, the LPI detect function maps the receive MII signals as normal conditions. At the start of LPI, indicated by the transition from normal inter-frame encoding to the "Assert LPI" encoding on the receive MII, the LPI detect function continues to indicate idle on interface and asserts LP\_IDLE indication. At the end of LPI, indicated by the transition from the "Assert LPI" encoding to any other encoding on the receive MII, LP\_IDLE indication is de-asserted and the normal decoding operation resumes.

### ***PHY LPI Transmit Operation***

When the PHY detects the start of "Assert LPI" encoding on the MII, the PHY signals sleep to its link partner to indicate that the local transmitter is entering LPI mode. The EEE capability requires the PHY transmitter to go quiet after sleep is signaled. LPI requests are passed from one end of the link to the other and system energy savings can be achieved even if the PHY link does not go into a low power mode.

The transmit function of the local PHY is enabled periodically to transmit refresh signals that are used by the link partner to update adaptive filters and timing circuits in order to maintain link integrity. This quiet-refresh cycle continues until the reception of the normal inter-frame encoding on the MII. The transmit function in the PHY communicates this to the link partner by sending a wake signal for a predefined period of time. The PHY then enters the normal operating state. No data frames are lost or corrupted during the transition to or from the LPI mode.

In 100BT/full-duplex EEE operation, refresh transmissions are used to maintain the link and the quiet periods are used for power saving. Approximately every 20-22ms a refresh of 200-220µs is sent to the link partner. The refresh transmission and quiet periods are shown in [Figure 8](#).

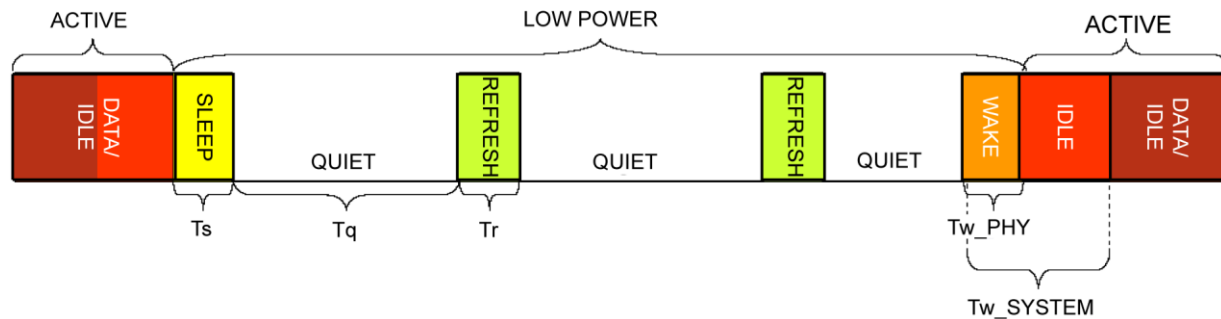

$T_s$  = THE PERIOD OF TIME THAT THE PHY TRANSMITS THE SLEEP SIGNAL BEFORE TURNING ALL TRANSMITTERS OFF,  $200 \leq T_s \leq 220$  USED IN 100BASE-TX.  
 $T_q$  = THE PERIOD OF TIME THAT THE PHY REMAINS QUIET BEFORE SENDING THE REFRESH SIGNAL,  $20_000 \leq T_q \leq 22_000$  USED IN 100BASE-TX.  
 $T_r$  = DURATION OF THE REFRESH SIGNAL,  $200 \leq T_r \leq 220$  USED IN 100BASE-TX.

**Figure 8. Traffic Activity and EEE LPI Operations**

### **PHY LPI Receive Operation**

On receive, entering the LPI mode is triggered by the reception of a sleep signal from the link partner, which indicates that the link partner is about to enter the LPI mode. After sending the sleep signal, the link partner ceases transmission. When the receiver detects the sleep signal, then the local PHY indicates “Assert LPI” on the MII and the local receiver can disable some functionality to reduce power consumption. The link partner periodically transmits refresh signals that are used by the local PHY. This quiet-refresh cycle continues until the link partner initiates transition back to normal mode by transmitting the wake signal for a predetermined period of time controlled by the LPI assert function. This allows the local receiver to prepare for normal operation and transition from the “Assert LPI” encoding to the normal inter-frame encoding on the MII. After a system-specified recovery time, the link supports the nominal operational data rate.

### **Negotiation with EEE Capability**

The EEE capability is advertised during the auto-negotiation stage. Auto-negotiation provides a linked device with the capability to detect the abilities supported by the device at the other end of the link, determine common abilities, and configure for joint operation. Auto-negotiation is performed at power-up or reset, on command from management, due to link failure, or due to user intervention.

During auto-negotiation, both link partners indicate their EEE capabilities. EEE is supported only if both the local device and link partner advertise the EEE capability for the resolved PHY type during auto-negotiation. If EEE is not supported, all EEE functionality is disabled and the LPI client does not assert LPI. If EEE is supported by both link partners for the negotiated PHY type, then the EEE function can be used independently in either direction.

### **Wake-on-LAN (WoL)**

Wake-on-LAN allows a computer to be turned on or woken up by a network message. The message is usually sent by a program executed on another computer on the same local area network. Wake-up frame events are used to wake the system whenever meaningful data is presented to the system over the network. Examples of meaningful data include the reception of a Magic Packet™, a management request from a remote administrator, or simply network traffic directly targeted to the local system. The KSZ8775CLX can be programmed to notify the host of the Wake-up frame detection with the assertion of the interrupt signal (INTR\_N) or assertion of the power management event (PME) signal. The PME control is by PME indirect registers.

KSZ8775CLX MAC supports the detection of the following Wake-up events:

- Detection of an energy signal over a pre-configured value: Port PME Control Status Register bit [0] in PME indirect registers.
- Detection of a link-up in the network link state: Port PME Control Status Register bit [1] in the PME indirect registers.
- Receipt of a Magic Packet: Port PME Control Status Register bit [2] in the PME indirect registers.



There are also other types of Wake-up events that are not listed here as manufacturers may choose to implement these in their own ways.

### ***Direction of Energy***

Energy is detected from the cable and is continuously presented for a time longer than the pre-configured value, especially when this energy change may impact the level at which the system should re-enter to the normal power state.

### ***Direction of Link-up***

Link status wake events are useful to indicate a link-up in the network's connectivity status.

### ***Magic Packet™***

The Magic Packet™ is a broadcast frame containing anywhere within its payload 6 bytes of all 1s (FF FF FF FF FF FF) followed by 16 repetitions of the target computer's 48-bit DA MAC address. Because the Magic Packet is only scanned for the above string, and not actually parsed by a full protocol stack, it may be sent as any network- and transport-layer protocol.

Magic Packet technology is used to remotely wake up a sleeping or powered-off PC on a LAN. This is accomplished by sending a specific packet of information, called a Magic Packet frame, to a node on the network. When a PC capable of receiving the specific frame goes to sleep, it enables the Magic Packet RX mode in the LAN controller. When the LAN controller receives a Magic Packet frame, it will alert the system to wake up. Once the KSZ8775CLX has been enabled for Magic Packet detection in Port PME Control Mask Register bit [2] in the PME indirect register, it scans all incoming frames addressed to the node for a specific data sequence that indicates to the controller this is a Magic Packet frame.

A Magic Packet frame must also meet the basic requirements for the LAN technology chosen, such as source address (SA), destination address (DA), which may be the receiving station's IEEE MAC address, or a multicast or broadcast address and CRC. The specific sequence consists of 16 duplications of the MAC address of this node with no breaks or interruptions. This sequence can be located anywhere within the packet, but must be preceded by a synchronization stream. The synchronization stream is defined as 6 bytes of 0xFF. The device will also accept a broadcast frame, as long as the 16 duplications of the IEEE address match the address of the machine to be awakened.

### ***Example of Magic Packet:***

If the IEEE address for a particular node on a network is 11h 22h, 33h, 44h, 55h, 66h, the LAN controller would be scanning for the data sequence (assuming an Ethernet frame):

```
DA - SA - TYPE - FF FF FF FF FF FF - 11 22 33 44 55 66 -11 22 33 44 55 66-11 22 33 44 55 66 - 11 22 33 44 55 66 - 11
22 33 44 55 66 - 11 22 33 44 55 66 - 11 22 33 44 55 66 - 11 22 33 44 55 66 - 11 22 33 44 55 66 - 11 22 33 44 55 66 - 11
22 33 44 55 66 - 11 22 33 44 55 66 - 11 22 33 44 55 66 - 11 22 33 44 55 66 - 11 22 33 44 55 66 - 11 22 33 44 55 66 -
MISC-CRC.
```

There are no further restrictions on a Magic Packet frame. For instance, the sequence could be in a TCP/IP packet or an IPX packet. The frame may be bridged or routed across the network without affecting its ability to wake-up a node at the frame's destination. If the scans do not find the specific sequence shown above, it discards the frame and takes no further action. If the KSZ8775CLX detects the data sequence, however, it then alerts the PC's power management circuitry (asserts the PME pin) to wake up the system.

### ***Interrupt (INT\_N/PME\_N)***

INT\_N is an interrupt signal that is used to inform the external controller that there has been a status update in the KSZ8775CLX interrupt status register. Bits [3:0] of Register 125 are the interrupt mask control bits to enable and disable the conditions for asserting the INT\_N signal. Bits [3:0] of Register 124 are the interrupt status bits to indicate which interrupt conditions have occurred. The interrupt status bits are cleared after reading those bits in the Register 124.

PME\_N is an optional PME interrupt signal that is used to inform the external controller that there has been a status update in the KSZ8775CLX interrupt status register. Bits [4] of Register 125 are the PME mask control bits to enable and disable the conditions for asserting the PME\_N signal. Bits [4] of Register 124 are the PME interrupt status bits to indicate which PME interrupt conditions have occurred. The PME interrupt status bit [4] is cleared after reading this bit of the Register 124.

Additionally, the interrupt pins of INT\_N and PME\_N eliminate the need for the processor to poll the switch for status change.

## Functional Overview: Interfaces

The KSZ8775CLX device incorporates a number of interfaces that enable it to be designed into a standard network environment as well as a vendor-unique environment. The available interfaces are summarized in the table below. The detail of each usage in this table is provided in the sections that follow.

**Table 3. Available Interfaces**

Interface	Type	Usage	Registers Accessed
SPI	Configuration and Register Access	[As Slave Serial Bus] - External CPU or controller can R/W all internal registers through this interface.	All
MIIM	Configuration and Register Access	MDC/MDIO-capable CPU or controllers can R/W 4 PHYs registers.	PHYs Only
GMII	Data Flow	Interface to the Port 5 GMAC using the standard GMII timing.	N/A
MII	Data Flow	Interface to the Port 5 GMAC using the standard MII timing.	N/A
RGMII	Data Flow	Interface to the Port 5 GMAC using the faster reduced GMII timing.	N/A
RMII	Data Flow	Interface to the Port 5 GMAC using the faster reduced MII timing.	N/A

### Configuration Interface

#### ***SPI Slave Serial Bus Configuration***

The KSZ8775CLX can also act as an SPI slave device. Through the SPI, the entire feature set can be enabled, including VLAN, IGMP snooping, MIB counters, and more. The external master device can access any register from Register 0 to Register 127 randomly. The system should configure all the desired settings before enabling the switch in the KSZ8775CLX. To enable the switch, write a "1" to Register 1 bit [0].

Two standard SPI commands are supported (00000011 for "READ DATA," and 00000010 for "WRITE DATA"). To speed configuration time, the KSZ8775CLX also supports multiple reads or writes. After a byte is written to or read from the KSZ8775CLX, the internal address counter automatically increments if the SPI slave select signal (SPIS\_N) continues to be driven low. If SPIS\_N is kept low after the first byte is read, the next byte at the next address will be shifted out on SPIQ. If SPIS\_N is kept low after the first byte is written, then bits on the master out slave input (SPID) line will be written to the next address. Asserting SPIS\_N high terminates a read or write operation. This means that the SPIS\_N signal must be asserted high and then low again before issuing another command and address. The address counter wraps back to zero once it reaches the highest address. Therefore, the entire register set can be written to or read from by issuing a single command and address.

The KSZ8775CLX is able to support a SPI bus up to 50MHz. A high performance SPI master is recommended to prevent internal counter overflow.

To use the KSZ8775CLX SPI:

1. At the board level, connect the KSZ8775CLX pins as follows.

**Table 4. SPI Connections**

KSZ8775CLX Signal Name	Microprocessor Signal Description
SPIS_N (S_CS)	SPI slave select
SCL (S_CLK)	SPI clock
SDA (S_DI)	Master out. Slave input.
SPIQ (S_DO)	Master input. Slave output.

2. Configure the serial communication to SPI slave mode by pulling down pin SPIQ with a pull-down resistor.

3. Write configuration data to registers using a typical SPI write data cycle as shown in Figure 9 or SPI multiple write as shown in Figure 10. Note that data input on SDA is registered on the rising edge of SCL clock.
4. Registers can be read and the configuration can be verified with a typical SPI read data cycle as shown in Figure 9 or a multiple read as shown in Figure 10. Note that read data is registered out of SPIQ on the falling edge of SCL clock.

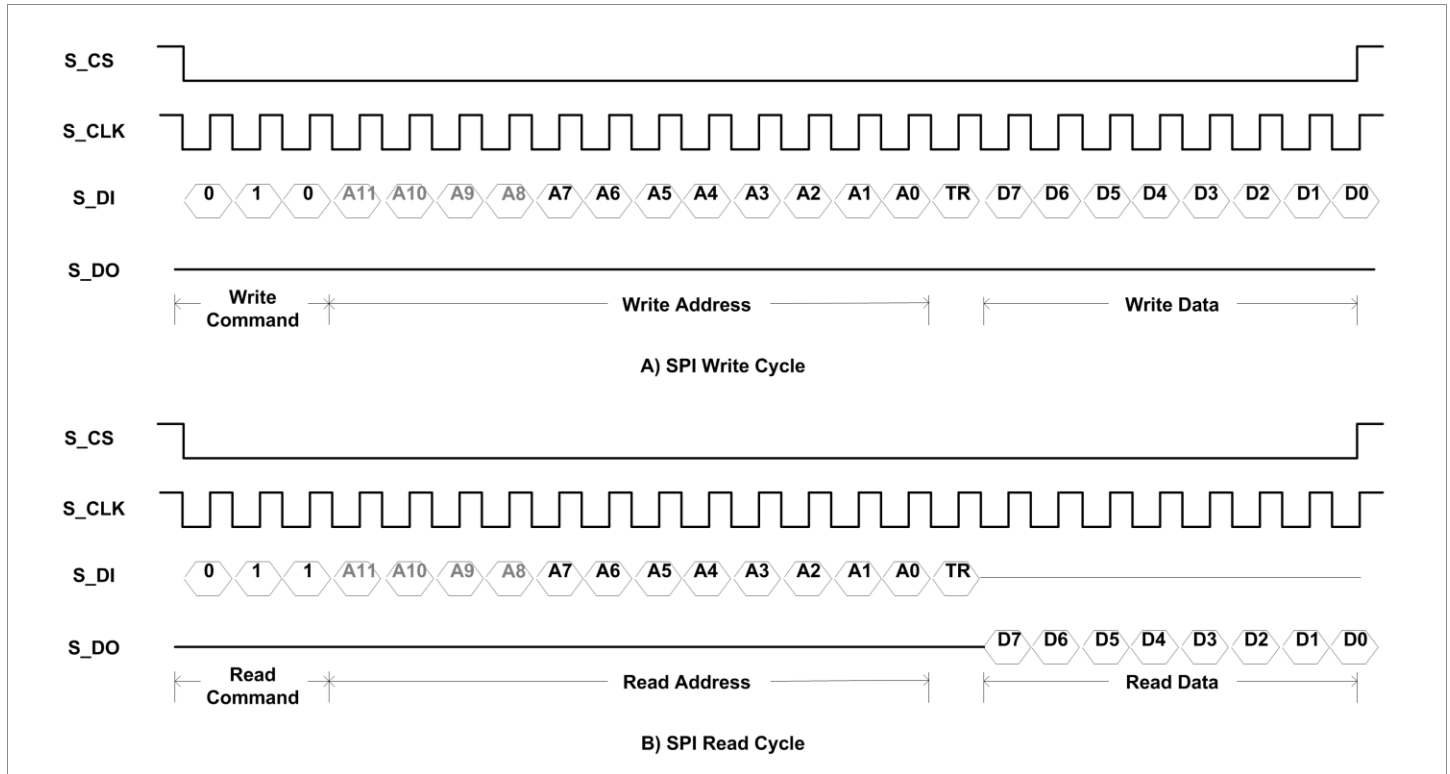

Figure 9. SPI Access Timing

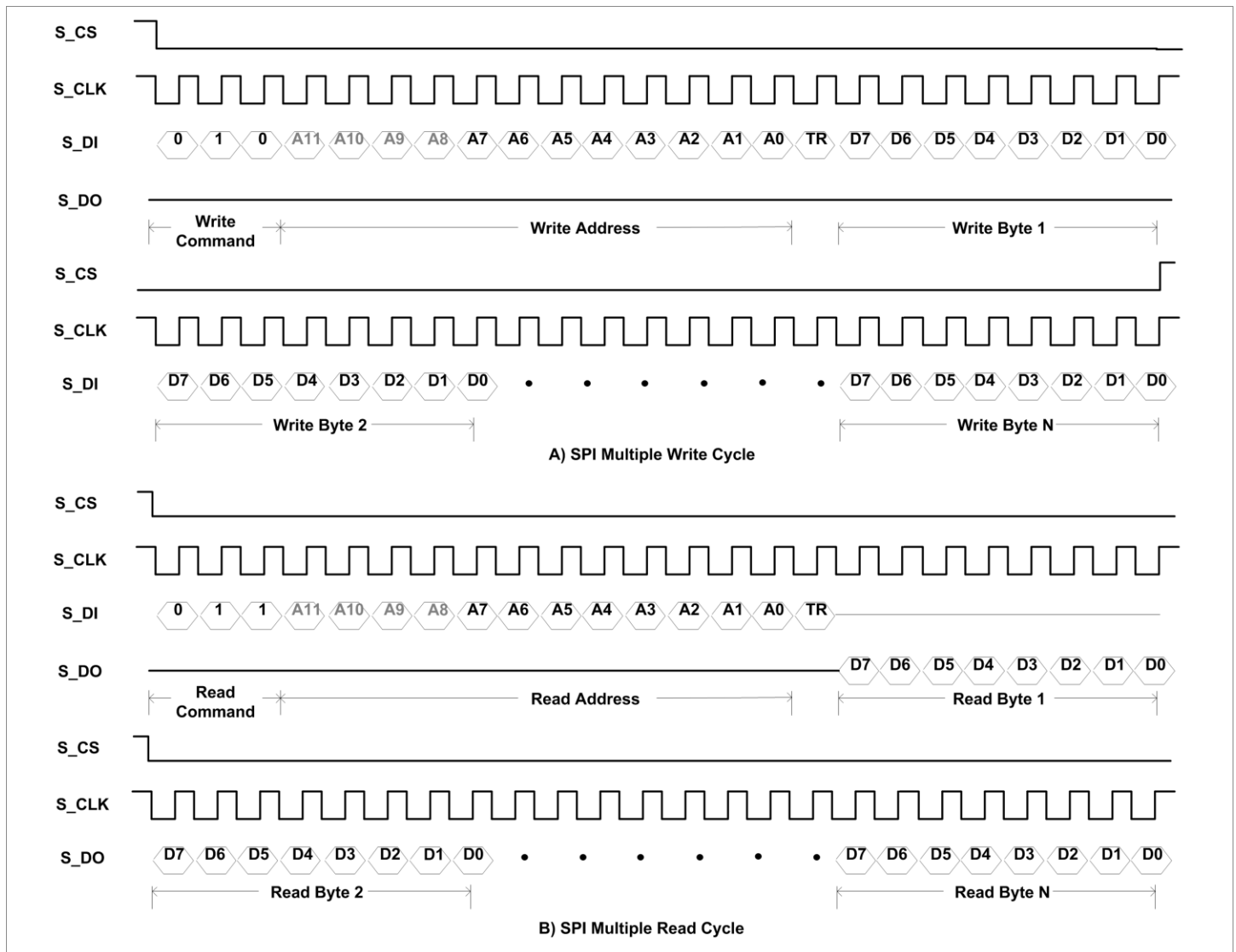

Figure 10. SPI Multiple Access Timing

### MIIM Management Interface (MIIM)

The KSZ8775CLX supports the standard IEEE 802.3 MIIM management interface, also known as the management data input/output (MDIO) interface. This interface allows upper-layer devices to monitor and control the states of the KSZ8775CLX. An external device with MDC/MDIO capability is used to read the PHY status or configure the PHY settings. Further details on the MIIM interface are found in clause 22.2.4.5 of the IEEE 802.3u specification.

The MIIM interface consists of the following:

- A physical connection that incorporates the data line MDIO and the clock line MDC.
- A specific protocol that operates across the aforementioned physical connection that allows an external controller to communicate with the KSZ8775CLX device.
- Access to a set of eight 16-bit registers, consisting of eight standard MIIM Registers [0:5h], 1d and 1f MIIM registers per port.

The MIIM interface can operate up to a maximum clock speed of 25MHz MDC clock.

The following table depicts the MIIM management interface frame format.

**Table 5. MIIM Management Interface Frame Format<sup>(4)</sup>**

	Preamble	Start of Frame	Read/Write OP Code	PHY Address Bits[4:0]	REG Address Bits[4:0]	TA	Data Bits[15:0]	Idle
<b>Read</b>	32 1s	01	10	AAAAA	RRRRR	Z0	DDDDDDDD_DDDDDDDD	Z
<b>Write</b>	32 1s	01	01	AAAAA	RRRRR	10	DDDDDDDD_DDDDDDDD	Z

**Note:**

4. Preamble: Consists of 32 1s

Start of Frame: The start of frame is indicated by a 01 pattern. This pattern assures transitions from the default logic one line state to zero and back to one.

OP Code: The operation code for a read transaction is 10, while the operation code for a write transaction is 01.

PHY Address: The PHY address is five bits, allowing 32 unique PHY addresses. The first PHY address bit transmitted and received is the MSB of the address.

REG Address: The register address is five bits, allowing 32 individual registers to be addressed within each PHY. The first register address bit transmitted and received is the MSB of the address.

TA: The turnaround (TA) time is 2-bit time spacing between the register address field and the data field of a frame to avoid contention during a read transaction. For a read transaction, both the master and the PHYs shall remain in a high-impedance state for the first bit time of the turnaround. The PHY shall drive a 0 bit during the second bit time of the turnaround of a read transaction. During a write transaction, the master shall drive a 1 bit for the first bit time of the turnaround and a 0 bit for the second bit time of the turnaround.

DATA: The data field is 16 bits. The first data bit transmitted and received shall be bit 15 of the register being addressed.

The MIIM interface does not have access to all the configuration registers in the KSZ8775CLX. It can only access the standard MIIM registers. See "MIIM Registers". The SPI interface, on the other hand, can be used to access all registers with the entire KSZ8775CLX feature set.

## Switch Port 4 MAC Interface

### Port 4 MAC4 SW4-RMII Interface

The reduced media independent interface (RMII) specifies a low pin-count media independent interface (MII). The KSZ8775CLX supports RMII interface at Port 4's switch side, provides a common interface at the MAC4 layer in the device, and has the following key characteristics:

- Supports 10Mbps and 100Mbps data rates.
- Uses a single 50MHz clock reference (provided internally or externally). In internal mode, the chip provides a reference clock from the RXC4 pin to the opposite clock input pin for RMII interface. In external mode, the chip receives a 50MHz reference clock on the REFCLKI4 pin from an external oscillator or opposite RMII interface.
- Provides independent 2-bit-wide (bi-bit) transmit and receive data paths.

In internal mode, and when using an internal 50MHz clock as SW4-RMII reference clock, the KSZ8775CLX Port 4 should be set to clock mode by the Strap Pin RXD4\_0 or the Port Register 70 bit[7]. The clock mode of the KSZ8775CLX device will provide the 50MHz reference clock to the Port 4 RMII interface.

In external mode, when using an external 50MHz clock source as SW4-RMII reference clock, the KSZ8775CLX Port 4 should be set to normal mode by the Strap Pin RXD4\_0 or Port Register 70 bit[7]. The normal mode of the KSZ8775CLX device will start to work when it gets the 50MHz reference clock from pin TXC4/REFCLKI4 from an external 50MHz clock source.

**Table 6. Port 4 SW4-RMII Connection**

SW4-RMII MAC-to-MAC Connection (PHY Mode)			Description	SW4-RMII MAC-to-PHY Connection (MAC Mode)		
External MAC	KSZ8775CLX SW4-RMII	Signal Type		External PHY	KSZ8775CLX SW4-RMII	Signal Type
REF_CLKI	RXC4	Output 50MHz in clock mode	Reference Clock	50MHz	REFCLKI4	Input 50MHz in normal mode
CRS_DV	RXDV4/CRSDV4	Output	Carrier Sense/Receive Data Valid	CRS_DV	TXEN4	Input
RXD[1:0]	RXD4[1:0]	Output	Receive Data Bit [1:0]	RXD[1:0]	TXD4[1:0]	Input
TX_EN	TXEN4	Input	Transmit Data Enable	TX_EN	RXDV4/CRSDV4	Output
TXD[1:0]	TXD4[1:0]	Input	Transmit Data Bit 1	TXD[1:0]	RXD4[1:0]	Output
50MHz	REFCLKI4	Input 50MHz in normal mode	Reference Clock	REF_CLKI	RXC4	Output 50MHz in clock mode

MAC/PHY mode in RMII is different from MAC/PHY mode in MII. There is no strap pin and register configuration request in RMII.

### Switch Port 5 GMAC Interface

The KSZ8775CLX GMAC5 interface supports four MII/RGMII/RMII interface protocols and shares one set of input/output signals. The purpose of this interface is to provide a simple, inexpensive, and easy-to-implement interconnection between the GMAC/MAC sub-layer and a GPHY/PHY. Data on these interfaces are framed using the IEEE Ethernet standard. As such, it consists of a preamble, start of frame delimiter, Ethernet headers, protocol-specific data, and a cyclic redundancy check (CRC) checksum.

Transmit and receive signals for MII/RGMII/RMII interfaces are shown in the table below.

**Table 7. Signals of RGMII/MII/RMII**

Direction Type	RGMII	MII	RMII
Input (Output)	GTXC	TXC	REFCLKI
Input		TXER	
Input	TXD_CTL	TXEN	TXEN
Input (Output)		COL	
Input	TXD[3:0]	TXD[3:0]	TXD[1:0]
Input (Output)	GRXC	RXC	RXC
Output		RXER	RXER
Output	RXD_CTL	RXDV	CRS_DV
Input (Output)		CRS	
Output	RXD[3:0]	RXD[3:0]	RXD[1:0]

#### **Standard Media Independent Interface (MII)**

For MII, the interface is capable of supporting 10/100Mbps operation. Data and delimiters are synchronous to clock references. It provides four independent transmit and receive data paths and uses signal levels; two media status signals are also provided. The CRS indicates the presence of carrier, and the COL indicates the occurrence of a collision. Both half- and full-duplex operations are provided by the MII interface.

MII transfers data using 4-bit words (nibble) in each direction, clocked at 2.5/25MHz to achieve 10/100Mbps speed.

#### **Reduced Media Independent Interface (RMII)**

RMII specifies a low pin count media independent interface. The KSZ8775CLX supports the RMII interface on the Port 5 GMAC5 and provides the following key characteristics:

- Supports 10Mbps and 100Mbps data rates.
- Uses a single 50MHz clock reference (provided internally or externally). In internal mode, the chip provides a reference clock from the RXC pin to the opposite clock input pin for RMII interface. In external mode, the chip receives 50MHz reference clock from an external oscillator or opposite RMII interface.
- Provides independent 2-bit wide (bi-bit) transmit and receive data paths.

#### **Reduced Gigabit Media Independent Interface (RGMII)**

RGMII is intended to be an alternative to the IEEE 802.3u MII and the IEEE 802.3z RGMII. The principle objective is to reduce the number of pins required to interconnect the GMAC and the GPHY in a cost-effective and technology-independent manner. In order to accomplish this, the data paths and all associated control signals are reduced, control signals are multiplexed together, and both edges of the clock are used. For Gigabit operation, the clocks operate at 125MHz with the rising edge and falling edge used to latch the data.

**Port 5 GMAC5 SW5-RGMII Interface**

The table below shows the RGMII reduced connections when connecting to an external GMAC or GPHY.

**Table 8. Port 5 SW5-RGMII Connection**

KSZ8775CLX SW5-RGMII Connection			
External GMAC/GPHY	SW5-RGMII Signals	Type	Description
MRX_CTL	TXD5_CTL	Input	Transmit Control
MRXD[3:0]	TXD5[3:0]	Input	Transmit Data Bit[3:0]
MRX_CLK	GTX5_CLK	Input	Transmit Clock
MTX_CTL	RXD5_CTL	Output	Receive Control
MTXD[3:0]	RXD5[3:0]	Output	Receive Data Bit[3:0]
MGTX_CLK	GRXC5	Output	Receive Clock

The RGMII interface operates at up to a 1Gbps speed rate. Additional transmit and receive signals control the different directions of data transfer. This RGMII interface supports RGMII Rev. 2.0 with adjustable ingress clock and egress clock delay by Register 86 (0x56).

For proper RGMII configuration with the connection partner, the Register 86 (0x56) bits [4:3] need to setup correctly. A configuration table is shown below.

**Table 9. Port 5 SW5-RGMII Clock Delay Configuration with Connection Partner**

KSZ8775 Register 86 Bits [4:3] Configuration	RGMII Clock Mode (Receive and Transmit)	KSZ8775 Register 86 (0x56)	KSZ8775 RGMII Clock Delay/Slew Configuration	Connection Partner RGMII Clock Configuration <sup>(5)</sup>
Bit [4:3] = 11 Mode	Ingress Clock Input	Bit [4] = 1	Delay	No Delay
	Egress Clock Output	Bit [3] = 1	Delay	No Delay
Bit [4:3] = 10 Mode	Ingress Clock Input	Bit [4] = 1	Delay	No Delay
	Egress Clock Output	Bit [3] = 0	No Delay	Delay
Bit [4:3] = 01 Mode	Ingress Clock Input	Bit [4] = 0 (default)	No Delay	Delay
	Egress Clock Output	Bit [3] = 1 (default)	Delay	No Delay
Bit [4:3] = 00 Mode	Ingress Clock Input	Bit [4] = 0	No Delay	Delay
	Egress Clock Output	Bit [3] = 0	No Delay	Delay

**Note:**

5. A processor with RGMII, an external GPHY, or KSZ8775 back-to-back connection.

For example, two KSZ8775 devices are the back-to-back connection. If one device set bit [4:3] = '11', another one should set bit [4:3] = '00'. If one device set bit [4:3] = '01', another one should set bit [4:3] = '01' too.

The RGMII mode is configured by the strap-in Pin LED3 [1:0] = '11' (default) or Register 86 (0x56) bits [1:0] = '11' (default). The speed choice is set by the strap-in pin LED1\_0 or Register 86 (0x56) bit [6], the default speed is 1Gbps with bit [6] = '1', set bit [6] = '0' is for 10/100Mbps speed in RGMII mode. KSZ8775CLX provides Register 86 bits [4:3] with the adjustable clock delay and Register 164 bits [6:4] with the adjustable drive strength for best RGMII timing on board level in 1Gbps mode.



**Port 5 GMAC5 SW5-MII Interface**

The table below shows two connection methods. The first is an external MAC connecting in SW5-MII PHY mode. The second is an external PHY connecting in SW5-MII MAC mode. The MAC mode or PHY mode setting is determined by the strap pin LED2\_1.

**Table 10. Port 5 SW5-MII Connection**

MAC-to-MAC Connection KSZ8775CLX MAC5 SW5-MII PHY Mode				MAC-to-PHY Connection KSZ8775CLX MAC5 SW5-MII MAC Mode		
External MAC	SW5-MII Signals	Type	Description	External PHY	SW5-MII Signals	Type
MTXEN	TXEN5	Input	Transmit Enable	MTXEN	RXDV5	Output
MTXER	TXER5	Input	Transmit Error	MTXER	RXER5	Output
MTXD[3:0]	TXD5[3:0]	Input	Transmit Data Bit[3:0]	MTXD[3:0]	RXD5[3:0]	Output
MTXC	TXC5	Output	Transmit Clock	MTXC	RXC5	Input
MCOL	COL5	Output	Collision Detection	MCOL	COL5	Input
MCRS	CRS5	Output	Carrier Sense	MCRS	CRS5	Input
MRXDV	RXDV5	Output	Receive Data Valid	MRXDV	TXEN5	Input
MRXER	RXER5	Output	Receive Error	MRXER	TXER5	Input
MRXD[3:0]	RXD5[3:0]	Output	Receive Data Bit[3:0]	MRXD[3:0]	TXD5[3:0]	Input
MRXC	RXC5	Output	Receive Clock	MRXC	TXC5	Input

The MII interface operates in either MAC mode or PHY mode. These interfaces are nibble-wide data interfaces, so they run at one-quarter the network bit rate (not encoded). Additional signals on the transmit side indicate when data is valid or when an error occurs during transmission. Likewise, the receive side has indicators that convey when the data is valid and without physical layer errors. For half-duplex operation, there is a COL signal that indicates a collision has occurred during transmission.

**Note:** Normally MRXER would indicate a receive error coming from the physical layer device. MTXER would indicate a transmit error from the MAC device. These signals are not appropriate for this configuration. For PHY mode operation with an external MAC, if the device interfacing with the KSZ8775CLX has an MRXER pin, it can be tied low. For MAC mode operation with an external PHY, if the device interfacing with the KSZ8775CLX has an MTXER pin, it can be tied low.

### Port 5 GMAC5 SW5-RMII Interface

The reduced media independent interface (RMII) specifies a low pin count media independent interface. The KSZ8775CLX supports RMII interface on Port 5 and provides the following key characteristics:

- Supports 10Mbps and 100Mbps data rates.
- Uses a single 50MHz clock reference (provided internally or externally): In internal mode, the chip provides a reference clock from the RXC5 pin to the opposite clock input pin for RMII interface when Port 5 RMII is set to clock mode.
- In external mode, the chip receives 50MHz reference clock on the TXC5/REFCLKI5 pin from an external oscillator or opposite RMII interface when the device is set to normal mode.
- Provides independent 2-bit wide (bi-bit) transmit and receive data paths.

For the details of SW5-RMII (Port 5 GMAC5 RMII) signal connection, see the table below:

When the device is strapped to normal mode, the reference clock comes from the TXC5/REFCLKI5 pin and will be used as the device's clock source. The strap pin LED1\_1 can select the device's clock source either from the TXC5/REFCLKI5 pin or from an external 25MHz crystal/oscillator clock on the XI/XO pin.

In internal mode, when using an internal 50MHz clock as SW5-RMII reference clock, the KSZ8775CLX Port 5 should be set to clock mode by the strap pin LED2\_1 or the port Register 86 bit[7]. The clock mode of the KSZ8775CLX device will provide the 50MHz reference clock to the Port 5 RMII interface.

In external mode, when using an external 50MHz clock source as SW5-RMII reference clock, the KSZ8775CLX Port 5 should be set to normal mode by the strap pin LED2\_1 or the port Register 86 bit[7]. The normal mode of the KSZ8775CLX device will start to work when it receives the 50MHz reference clock on the TXC5/REFCLKI5 pin from an external 50MHz clock source.

**Table 11. Port 5 SW5-RMII Connection<sup>(6)</sup>**

MAC-to-MAC Connection KSZ8775CLX SW5-RMII PHY Mode				MAC-to-PHY Connection KSZ8775CLX SW5-RMII MAC Mode		
External MAC	SW5-RMII Signals	Type	Description	External PHY	SW5-RMII Signals	Type
REF_CLKI	RXC5	Output 50MHz in Clock Mode	Reference Clock	50MHz	REFCLKI5	Input 50MHz in Normal Mode
CRS_DV	RXDV5/CRSDV5	Output	Carrier Sense/Receive Data Valid	CRS_DV	TXEN5	Input
			Receive Error	RXER	TXER5	Input
RXD[1:0]	RXD5[1:0]	Output	Receive Data Bit[1:0]	RXD[1:0]	TXD5[1:0]	Input
TX_EN	TXEN5	Input	Transmit Data Enable	TX_EN	RXDV5/CRSDV5	Output
TXD[1:0]	TXD5[1:0]	Input	Transmit Data Bit 1	TXD[1:0]	RXD5[1:0]	Output
50MHz	REFCLKI5	Input 50MHz in Normal Mode	Reference Clock	REF_CLKI	RXC5	Output 50MHz in Clock Mode

**Note:**

6. MAC/PHY mode in RMII is different from MAC/PHY mode in MII. There is no strap pin and register configuration request in RMII; just follow the signal connections in the table above.

## Functional Overview: Advanced Functionality

### QoS Priority Support

The KSZ8775CLX provides quality of service (QoS) for applications such as VoIP and video conferencing. The KSZ8775CLX offers one, two, or four priority queues per port by setting the Port Control 13 Registers bit [1] and the Port Control 0 Registers bit [0]. The 1/2/4 queues split as follows.

- [Port Control 9 Registers bit [1], Control 0 bit [0]] = 00 Single output queue as default.
- [Port Control 9 Registers bit [1], Control 0 bit [0]] = 01 Egress port can be split into two priority transmit queues.
- [Port Control 9 Registers bit [1], Control 0 bit [0]] = 10 Egress port can be split into four priority transmit queues.

The four priority transmit queue is a new feature in the KSZ8775CLX. Queue 3 is the highest priority queue and Queue 0 is the lowest priority queue. The Port Control 9 Registers bit [1] and the Port Control 0 Registers bit [0] are used to enable split transmit queues for Ports 1, 2, 3, 4, and 5, respectively. If a port's transmit queue is not split, high priority and low priority packets have equal priority in the transmit queue.

There is an additional option to either always deliver high priority packets first or to use programmable weighted fair queuing for the four priority queue scale by the Port Control 14, 15, 16, and 17 Registers (default values are 8, 4, 2, 1 by their bits [6:0]).

Register 130 bit [7:6] Prio\_2Q[1:0] is used when the two-queue configuration is selected. These bits are used to map the 2-bit result of IEEE 802.1p from Registers 128 and 129 or ToS/DiffServ mapping from Registers 144-159 (for four queues) into two-queue mode with priority high or low.

Please see the descriptions of Register 130 bits [7:6] for more detail.

### Port-Based Priority

With port-based priority, each ingress port is individually classified as a priority 0-3 receiving port. All packets received at the priority 3 receiving port are marked as high priority and are sent to the high-priority transmit queue if the corresponding transmit queue is split. The Port Control 0 Registers bits [4:3] is used to enable port-based priority for Ports 1, 2, 3, 4, and 5, respectively.

### 802.1p-Based Priority

For 802.1p-based priority, the KSZ8775CLX examines the ingress (incoming) packets to determine whether they are tagged. If tagged, the 3-bit priority field in the VLAN tag is retrieved and compared against the “priority mapping” value, as specified by Registers 128 and 129. Both Register 128 and 129 can map 3-bit priority fields of 0-7 value to 2-bit results of 0-3 priority levels. The priority mapping value is programmable.

The following figure illustrates how the 802.1p priority field is embedded in the 802.1Q VLAN tag.

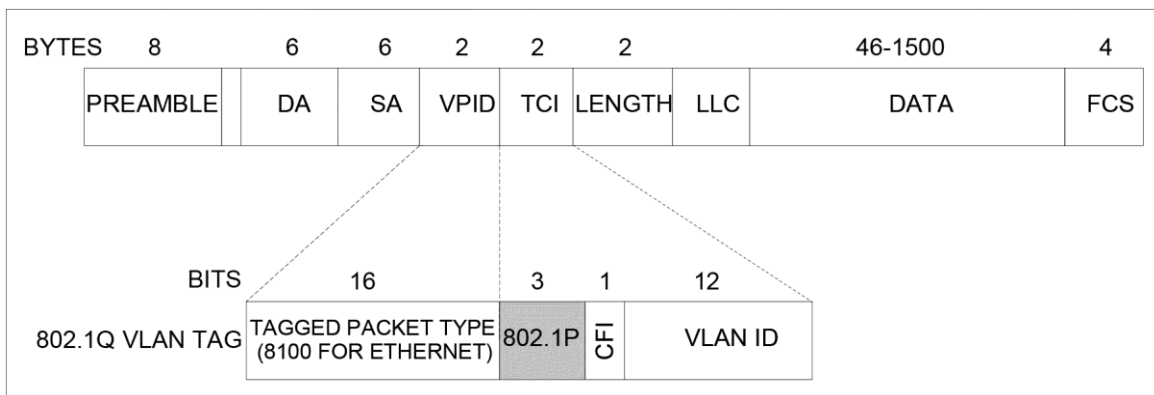

Figure 11. 802.1p Priority Field Format

802.1p-based priority is enabled by bit [5] of the Port Control 0 Registers for Ports 1, 2, 3, 4, and 5, respectively.

The KSZ8775CLX provides the option to insert or remove the priority tagged frame's header at each individual egress port. This header, consisting of the two-byte VLAN protocol ID (VPID) and the two-byte tag control information (TCI) field, is also referred to as the IEEE 802.1Q VLAN tag.

Tag insertion is enabled by bit[2] of the Port Control 0 Registers and the Port Control 8 Registers to select which source port (ingress port) PVID can be inserted on the egress port for Ports 1, 2, 3, 4, and 5, respectively. At the egress port, untagged packets are tagged with the ingress port's default tag. The default tags are programmed in the Port Control 3 and Control 4 Registers for Ports 1, 2, 3, 4, and 5, respectively. The KSZ8775CLX will not add tags to already tagged packets.

Tag removal is enabled by bit [1] of the Port Control 0 Registers for Ports 1, 2, 3, 4, and 5, respectively. At the egress port, tagged packets will have their IEEE 802.1Q VLAN tags removed. The KSZ8775CLX will not modify untagged packets.

The CRC is recalculated for both tag insertion and tag removal.

IEEE 802.1p priority field re-mapping is a QoS feature that allows the KSZ8775CLX to set the user priority ceiling at any ingress port by the Port Control 2 Register bit [7]. If the ingress packet's priority field has a higher priority value than the default tag's priority field of the ingress port, the packet's priority field is replaced with the default tag's priority field.

### ***DiffServ-Based Priority***

DiffServ-based priority uses the ToS registers (Registers 144 to 159) in the advanced control registers section. The ToS priority control registers implement a fully decoded, 128-bit differentiated services code point (DSCP) register to determine packet priority from the 6-bit ToS field in the IP header. When the most significant six bits of the ToS field are fully decoded, 64 code points for DSCP result. These are compared with the corresponding bits in the DSCP register to determine priority.

### **Spanning Tree Support**

Port 5 is the designated port for spanning tree support.

The other ports (Port 1 through Port 4) can be configured in one of the five spanning tree states via transmit enable, receive enable, and learning disable register settings in Registers 18, 34, 50, and 66 for Ports 1, 2, 3, and 4, respectively.

The KSZ8775CLX supports common spanning tree (CST). To support spanning tree, the host port (Port 5) is the designated port for the processor. The other ports can be configured in one of the five spanning tree states via transmit enable, receive enable, and learning disable register settings in Port Control 2 Registers. The following table shows the port setting and software actions taken for each of the five spanning tree states.

**Table 12. Port Settings and Software Actions for Spanning Tree States**

<b>Disable State</b>	<b>Port Setting</b>	<b>Software Action</b>
The port should not forward or receive any packets. Learning is disabled.	Transmit enable = 0, Receive enable = 0, Learning disable = 1	The processor should not send any packets to the port. The switch may still send specific packets to the processor (packets that match some entries in the static table with overriding bit set) and the processor should discard those packets. <b>Note:</b> the processor is connected to Port 5 via MII interface. Address learning is disabled on the port in this state.
<b>Blocking State</b>	<b>Port Setting</b>	<b>Software Action</b>
Only packets to the processor are forwarded. Learning is disabled.	Transmit enable = 0, Receive enable = 0, Learning disable = 1	The processor should not send any packets to the port(s) in this state. The processor should program the static MAC table with the entries that it needs to receive (e.g., BPDU packets). The overriding bit should also be set so that the switch will forward those specific packets to the processor. Address learning is disabled on the port in this state.
<b>Listening State</b>	<b>Port Setting</b>	<b>Software Action</b>
Only packets to and from the processor are forwarded. Learning is disabled.	Transmit enable = 0, Receive enable = 0, Learning disable = 1	The processor should program the static MAC table with the entries that it needs to receive (e.g. BPDU packets). The overriding bit should be set so that the switch will forward those specific packets to the processor. The processor may send packets to the port(s) in this state, see Tail Tagging Mode section for details. Address learning is disabled on the port in this state.
<b>Learning State</b>	<b>Port Setting</b>	<b>Software Action</b>
Only packets to and from the processor are forwarded. Learning is enabled.	Transmit enable = 0, Receive enable = 0, Learning disable = 0	The processor should program the static MAC table with the entries that it needs to receive (e.g., BPDU packets). The overriding bit should be set so that the switch will forward those specific packets to the processor. The processor may send packets to the port(s) in this state, see Tail Tagging Mode section for details. Address learning is enabled on the port in this state.
<b>Forwarding State</b>	<b>Port Setting</b>	<b>Software Action</b>
Packets are forwarded and received normally. Learning is enabled.	Transmit enable = 1, Receive enable = 1, Learning disable = 0	The processor should program the static MAC table with the entries that it needs to receive (e.g., BPDU packets). The overriding bit should be set so that the switch will forward those specific packets to the processor. The processor may send packets to the port(s) in this state, see Tail Tagging Mode section for details. Address learning is enabled on the port in this state.

## Rapid Spanning Tree Support

There are three operational states—discarding, learning, and forwarding—assigned to each port for RSTP. Discarding ports do not participate in the active topology and do not learn MAC addresses. Ports in the learning states learn MAC addresses, but do not forward user traffic. Ports in the forwarding states fully participate in both data forwarding and MAC learning. RSTP uses only one type of BPDU called RSTP BPDUs. They are similar to STP configuration BPDUs with the exception of a type field set to “version 2” for RSTP, “version 0” for STP, and a flag field carrying additional information.

**Table 13. Port Settings and Software Actions for Rapid Spanning Tree States**

Disable State	Port Setting	Software Action
The state includes three states of the disable, blocking and listening of STP.	Transmit enable = 0, Receive enable = 0, Learning disable = 1	The processor should not send any packets to the port. The switch may still send specific packets to the processor (packets that match some entries in the static table with overriding bit set) and the processor should discard those packets. When disabling the port's learning capability (learning disable = '1'), set the Register 1 bit [5] and bit [4] will rapidly the port-related entries in the dynamic MAC table and static MAC table. <b>Note:</b> processor is connected to Port 5 via MII interface. Address learning is disabled on the port in this state.
Learning State	Port Setting	Software Action
Only packets to and from the processor are forwarded. Learning is enabled.	Transmit enable = 0, Receive enable = 0, Learning disable = 0	The processor should program the static MAC table with the entries that it needs to receive (e.g., BPDU packets). The overriding bit should be set so that the switch will forward those specific packets to the processor. The processor may send packets to the port(s) in this state, see Tail Tagging Mode section for details. Address learning is enabled on the port in this state.
Forwarding State	Port Setting	Software Action
Packets are forwarded and received normally. Learning is enabled.	Transmit enable = 1, Receive enable = 1, Learning disable = 0	The processor should program the static MAC table with the entries that it needs to receive (e.g., BPDU packets). The overriding bit should be set so that the switch will forward those specific packets to the processor. The processor may send packets to the port(s) in this state, see Tail Tagging Mode section for details. Address learning is enabled on the port in this state.

**Tail Tagging Mode**

The tail tag is only seen and used by the Port 5 interface, which should be connected to a processor by the SW5-RGMII, MII, or RMII interfaces. One byte tail tagging is used to indicate the source/destination port on Port 5. Only bits [3:0] are used for the destination in the tail tagging byte. Other bits are not used. The tail tag feature is enabled by setting Register 12 bit [1].

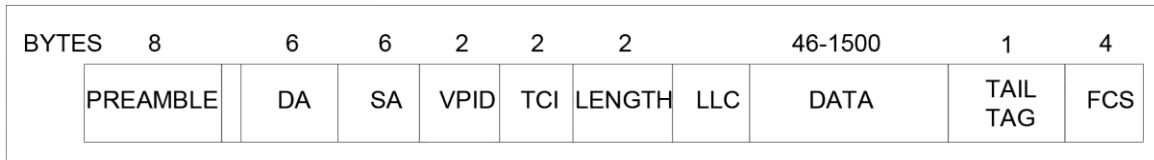

**Figure 12. Tail Tag Frame Format**

**Table 14. Tail Tag Rules**

<b>Ingress to Port 5 (Host to KSZ8775CLX)</b>	
Bits [3:0]	Destination
0,0,0,0	Reserved
0,0,0,1	Port 1 (direct forward to Port 1)
0,0,1,0	Port 2 (direct forward to Port 2)
0,1,0,0	Port 3 (direct forward to Port 3)
1,0,0,0	Port 4 (direct forward to Port 4)
1,1,1,1	Port 1, 2, 3, and 4 (direct forward to Port 1, 2, 3,4)
Bits [7:4]	
0,0,0,0	Queue 0 is used at destination port
0,0,0,1	Queue 1 is used at destination port
0,0,1,0	Queue 2 is used at destination port
0,0,1,1	Queue 3 is used at destination port
0, 1,x,x	Anyhow send packets to specified port in bits [3:0]
1, x,x,x	Bits [6:0] will be ignored as normal (address look-up)
<b>Egress from Port 5 (KSZ8775CLX to Host)</b>	
Bits [1:0]	Source
0,0	Port 1 (packets from Port 1)
0,1	Port 2 (packets from Port 2)
1,0	Port 3 (packets from Port 3)
1,1	Port 4 (packets from Port 4)

## IGMP Support

There are two components involved with the support of the Internet Group Management Protocol (IGMP) in Layer 2. The first part is IGMP snooping, the second part is this IGMP packet which is sent back to the subscribed port. Those components are described below.

- **IGMP Snooping:** The KSZ8775CLX traps IGMP packets and forwards them only to the processor (Port 5 SW5-RGMII/MII/RMII). The IGMP packets are identified as IP packets (either Ethernet IP packets, or IEEE 802.3 SNAP IP packets) with IP version = 0x4 and protocol version number = 0x2. Set Register 5 bit [6] to '1' to enable IGMP snooping.
- **IGMP Send Back to the Subscribed Port:** Once the host responds to the received IGMP packet, the host knows the original IGMP ingress port and sends the IGMP packet back to this port only. It does this in order to avoid this IGMP packet being broadcast to all ports, which will downgrade the performance. With tail tag mode enabled, the host will know the port from which that IGMP packet has been received via tail tag bits [1:0] and can send back the response IGMP packet to this subscribed port by setting bits [3:0] in the tail tag. Enable tail tag mode by setting Register 12 bit [1].

## IPv6 MLD Snooping

The KSZ8775CLX traps IPv6 multicast listener discovery (MLD) packets and forwards them only to the processor (Port 5). MLD snooping is controlled by Register 164 bit [2] (MLD snooping enable) and Register 164 bit [3] (MLD option).

With MLD snooping enabled, the KSZ8775CLX traps packets that meet all of the following conditions:

- IPv6 multicast packets
- Hop count limit = 1
- IPv6 next header = 1 or 58 (or = 0 with hop-by-hop next header = 1 or 58). If the MLD option bit is set to "1", the KSZ8775CLX traps packets with the following additional condition:
  - IPv6 next header = 43, 44, 50, 51, or 60 (or = 0 with hop-by-hop next header = 43, 44, 50, 51, or 60)

For MLD snooping, tail tag mode also needs to be enabled, so that the processor knows on which port the MLD packet was received. This is achieved by setting Register 12 bit [1].

## Port Mirroring Support

The KSZ8775CLX supports port mirroring as described below:

- "Receive Only" mirror on a port: All the packets received on the port will be mirrored on the sniffer port. For example, Port 1 is programmed to be "RX sniff" and Port 5 is programmed to be the "sniffer port." A packet, received on Port 1, is destined to Port 4 after the internal look-up. The KSZ8775CLX will forward the packet to both Port 4 and Port 5. KSZ8775CLX can optionally forward "bad" received packets to Port 5.
- "Transmit Only" mirror on a port: All the packets transmitted on the port will be mirrored on the sniffer port. For example, Port 1 is programmed to be "TX sniff," and Port 5 is programmed to be the "sniffer port." A packet, received on any of the ports, is destined to Port 1 after the internal look-up. The KSZ8775CLX will forward the packet to both Ports 1 and 5.
- "Receive and Transmit" mirror on two ports: All the packets received on Port A and transmitted on Port B will be mirrored on the sniffer port. To turn on the "AND" feature, set Register 5 bit [0] to '1'. For example, Port 1 is programmed to be "RX sniff," Port 2 is programmed to be "TX sniff," and Port 5 is programmed to be the "sniffer port." A packet, received on Port 1, is destined to Port 4 after the internal look-up. The KSZ8775CLX will forward the packet to Port 4 only, because it does not meet the "AND" condition. A packet, received on Port 1, is destined to Port 2 after the internal look-up. The KSZ8775CLX will forward the packet to both Port 2 and Port 5.

Multiple ports can be selected to be "RX sniff" or "TX sniff." Any port can be selected to be the "sniffer port." All these per port features can be selected through the Port Control 1 Register.



## VLAN Support

The KSZ8775CLX supports 128 active VLANs and 4096 possible VIDs specified in IEEE 802.1q. KSZ8775CLX provides a 128-entry VLAN table, which correspond to 4096 possible VIDs and converts to FID (7 bits) for address look-up, with a maximum of 128 active VLANs. If a non-tagged or null-VID-tagged packet is received, then the ingress port VID is used for look-up when IEEE 802.1q is enabled by the global Register 5 Control 3 bit [7]. In the VLAN mode, the look-up process starts from the VLAN table look-up to determine whether the VID is valid. If the VID is not valid, the packet will then be dropped and its address will not be learned. If the VID is valid, FID is retrieved for further look-up by the static MAC table or dynamic MAC table. FID+DA is used to determine the destination port. The following table describes the different actions in different situations of DA and FID+DA in the static MAC table and dynamic MAC table after the VLAN table finishes a look-up action. FID+SA is used for learning purposes. The following table also describes learning in the dynamic MAC table when the VLAN table has completed a look-up in the static MAC table without a valid entry.

**Table 15. FID+DA Look-Up in the VLAN Mode**

DA Found in Static MAC Table?	Use FID Flag?	FID Match?	DA+FID Found in Dynamic MAC Table?	Action
No	Don't Care	Don't Care	No	Broadcast to the membership ports defined in the VLAN table bits [11:7].
No	Don't Care	Don't Care	Yes	Send to the destination port defined in the dynamic MAC table bits [58:56].
Yes	0	Don't Care	Don't Care	Send to the destination port(s) defined in the static MAC table bits [52:48].
Yes	1	No	No	Broadcast to the membership ports defined in the VLAN table bits [11:7].
Yes	1	No	Yes	Send to the destination port defined in the dynamic MAC table bits [58:56].
Yes	1	Yes	Don't Care	Send to the destination port(s) defined in the static MAC table bits [52:48].

**Table 16. FID+SA Look-Up in the VLAN Mode**

SA+FID Found in Dynamic MAC Table?	Action
No	The SA+FID will be learned into the dynamic table.
Yes	Time stamp will be updated.

Advanced VLAN features are also supported in KSZ8775CLX, such as VLAN ingress filtering and discard non-PVID defined in bits [6:5] of the Port Control 2 Register. These features can be controlled on a per port basis.

## Rate Limiting Support

The KSZ8775CLX provides a fine resolution hardware rate limiting based on both bps (bits per second) and pps (packets per second).

For bps, the rate step is 64kbps when the rate limit is less than 1Mbps for 100BT or 10BT and 640kbps for 1000. The rate step is 1Mbps when the rate limit is more than 1Mbps for 100BT or 10BT and 10Mbps for 1000.

For pps, the rate step is 128pps (besides the 1st one which is 64pps) when the rate limit is less than 1Mbps for 100BT or 10BT and 1280pps (except the 1st one of 640pps) for 1000. The rate step is 1Mbps when the rate limit is more than 1.92kpps for 100BT or 10BT 19.2kpps for 1000.

The data rate selection table is below. Note that the pps limiting is bounded by bps rate for each pps setting; the mapping is shown in the second column of the table.

**Table 17. 10/100/1000Mbps Rate Selection for the Rate Limit**

Item	bps Bound of pps (Egress Only)	10Mbps		100Mbps		1000Mbps	
		pps	bps	pps	bps	pps	bps
7'd0	7'd0	19.2kpps	10Mbps	192kpps	100Mbps	1.92Mpps	1000Mbps
7d'1 to 7d'10	7d'3,6, (8x)10	1.92kpps * code	1Mbps * code	1.92kpps * code	1Mbps * code	19.2kpps * code	10Mbps * code
7d'11 to 7d'100	7d'11 – 7d'100		10Mbps	1.92kpps * code	1Mbps * code	19.2kpps * code	10Mbps * code
7d'101	7d'102	64pps	64kbps	64pps	64kbps	640pps	640kbps
7d'102	7d'104	128pps	128kbps	128pps	128kbps	1280pps	1280kbps
7d'103	7d'108	256pps	192kbps	256pps	192kbps	2560pps	1920kbps
7d'104	7d'112	384pps	256kbps	384pps	256kbps	3840pps	2560kbps
7d'105	7d'001	512pps	320kbps	512pps	320kbps	5120pps	3200kbps
7d'106	7d'001	640pps	384kbps	640pps	384kbps	6400pps	3840kbps
7d'107	7d'001	768pps	448kbps	768pps	448kbps	7680pps	4480kbps
7d'108	7d'002	896pps	512kbps	896pps	512kbps	8960pps	5120kbps
7d'109	7d'002	1024pps	576kbps	1024pps	576kbps	10240pps	5760kbps
7d'110	7d'002	1152pps	640kbps	1152pps	640kbps	11520pps	6400kbps
7d'111	7d'002	1280pps	704kbps	1280pps	704kbps	12800pps	7040kbps
7d'112	7d'002	1408pps	768kbps	1408pps	768kbps	14080pps	7680kbps
7d'113	7d'003	1536pps	832kbps	1536pps	832kbps	15360pps	8320kbps
7d'114	7d'003	1664pps	896kbps	1664pps	896kbps	16640pps	8960kbps
7d'115	7d'003	1792pps	969kbps	1792pps	969kbps	17920pps	9690kbps

The rate limit operates independently on the “receive side” and on the “transmit side” on a per port basis. For 10BASE-T, a rate setting above 10Mbps means the rate is not limited.

On the receive side, the data receive rate for each priority at each port can be limited by setting up ingress rate control registers. On the transmit side, the data transmit rate for each queue at each port can be limited by setting up egress rate control registers. For bps mode, the size of each frame has options to include minimum inter-frame gap (IFG) or preamble byte, in addition to the data field (from packet DA to FCS).

### ***Ingress Rate Limit***

For ingress rate limiting, the KSZ8775CLX provides options to selectively choose frames from all types: multicast, broadcast, and flooded unicast frames via bits [3:2] of the Port Rate Limit Control Register. The KSZ8775CLX counts the data rate from those selected type of frames. Packets are dropped at the ingress port when the data rate exceeds the specified rate limit or the flow control takes effect without packet dropped when the ingress rate limit flow control is enabled by the Port Rate Limit Control Register bit [4]. The ingress rate limiting supports the port-based, IEEE 802.1p and DiffServ-based priorities, the port-based priority is fixed priority 0-3 selection by bits [4:3] of the Port Control 0 Register. The IEEE 802.1p and DiffServ-based priority can be mapped to priority 0-3 by default of the Register 128 and 129. In the ingress rate limit, set Register 135 Global Control 19 bit [3] to enable queue-based rate limiting if using two-queue or four-queue mode. All related ingress ports and egress ports should be split to two-queue or four-queue mode by the Port Control 9 and Control 0 Registers. The four-queue mode will use Q0-Q3 for priority 0-3 by bits [6:0] of the Port Register Ingress Limit Control 1-4. The two-queue mode will use Q0-Q1 for priority 0-1 by bits [6:0] of the port ingress limit control 1-2 Registers. The priority levels in the packets of the IEEE 802.1p and DiffServ can be programmed to priority 0-3 via the Register 128 and 129 for re-mapping.

### ***Egress Rate Limit***

For egress rate limiting, the leaky bucket algorithm is applied to each output priority queue for shaping output traffic. Inter-frame gap is stretched on a per frame basis to generate smooth, non-burst egress traffic. The throughput of each output priority queue is limited by the egress rate specified by the data rate selection table followed by the egress rate limit control registers.

If any egress queue receives more traffic than the specified egress rate throughput, packets may be accumulated in the output queue and packet memory. After the memory of the queue or the port is used up, packet dropping or flow control will be triggered. As a result of congestion, the actual egress rate may be dominated by flow control/dropping at the ingress, and may be slightly less than the specified egress rate. The egress rate limiting supports the port-based, IEEE 802.1p- and DiffServ-based priorities. The port-based priority is fixed priority 0-3 selection by bits [4:3] of the Port Control 0 Register. The IEEE 802.1p and DiffServ-based priority can be mapped to priority 0-3 by default of the Register 128 and 129. In the egress rate limit, set Register 135 Global Control 19 bit [3] to enable queue-based rate limiting if using two-queue or four-queue mode. All related ingress ports and egress ports should be split to two-queue or four-queue mode by the Port Control 9 and Control 0 Registers. The four-queue mode will use Q0-Q3 for priority 0-3 by bits [6:0] of the Port Egress Limit Control 1-4 Register. The two-queue mode will use Q0-Q1 for priority 0-1 by bits [6:0] of the Port Egress Rate Limit Control 1-2 Register. The priority levels in the packets of the IEEE 802.1p and DiffServ can be programmed to priority 0-3 by Register 128 and 129 for re-mapping.

When the egress rate is limited, just use one queue per port for the egress port rate limit. The priority packets will be based upon the data rate selection table (see [Table 17](#)). If the egress rate limit uses more than one queue per port for the egress port rate limit, then the highest priority packets will be based upon the data rate selection table for the rate limit's exact number. Other lower priority packet rates will be limited based upon an 8:4:2:1 (default) priority ratio, which is based on the highest priority rate. The transmit queue priority ratio is programmable.

To reduce congestion, it is good practice to make sure the egress bandwidth exceeds the ingress bandwidth.

### ***Transmit Queue Ratio Programming***

In transmit queues 0-3 of the egress port, the default priority ratio is 8:4:2:1. The priority ratio can be programmed by the Port Control 10, 11, 12, and 13 Registers. When the transmit rate exceeds the ratio limit in the transmit queue, the transmit rate will be limited by the transmit queue 0-3 ratio of the Port Control 10, 11, 12, and 13 Registers. The highest priority queue will not be limited. Other lower priority queues will be limited based on the transmit queue ratio.

## VLAN and Address Filtering

To prevent certain kinds of packets that could degrade the quality of the switch in applications such as voice over Internet protocol (VoIP), the switch provides the mechanism to filter and map the packets with the following MAC addresses and VLAN IDs.

- Self-address packets
- Unknown unicast packets
- Unknown multicast packets
- Unknown VID packets
- Unknown IP multicast packets

The packets sourced from switch itself can be filtered out by enabling self-address filtering via the Global Control 18 Register bit [6]. The self-address filtering will filter packets on the egress port, self MAC address is assigned in the Register 104-109 MAC Address Registers 0-5.

The unknown unicast packet filtering can be enabled by the Global Control Register 15 bit [5] and bits [4:0] specify the port map for forwarding.

The unknown multicast packet filtering can be enabled by the Global Control Register 16 bit [5] and the forwarding port map is specified in bits [4:0].

The unknown VID packet filtering can be enabled by Global Control Register 17 bit [5] with the forwarding port map specified in bits [4:0].

The unknown IP multicast packet filtering can be enabled by Global Control Register 18 bit [5] with the forwarding port map specified in bits [4:0].

The filters above are globally based.

## IEEE 802.1x Port-Based Security

IEEE 802.1x is a port-based authentication protocol. EAPOL is the protocol normally used by the authentication process as an uncontrolled port. By receiving and extracting special EAPOL frames, the microprocessor (CPU) can control whether the ingress and egress ports should forward packets or not. If a user port wants service from another port (authenticator), it must get approval from the authenticator. The KSZ8775CLX detects EAPOL frames by checking the destination address of the frame. The destination addresses should be either a multicast address as defined in IEEE 802.1x (01-80-C2-00-00-03) or an address used in the programmable reserved multicast address domain with offset -00-03. Once EAPOL frames are detected, the frames are forwarded to the CPU so it can send the frames to the authenticator server. Eventually, the CPU determines whether the requestor is qualified or not based on its MAC\_Source addresses and frames are either accepted or dropped.

When the KSZ8775CLX is configured as an authenticator, the ports of the switch must then be configured for authorization. In an authenticator-initiated port authorization, a client is powered-up or plugs into the port and the authenticator port sends an extensible authentication protocol (EAP) PDU to the supplicant requesting the identification of the supplicant. At this point in the process, the port on the switch is connected from a physical standpoint; however, the IEEE 802.1x process has not authorized the port and no frames are passed from the port on the supplicant into the switching fabric. If the PC attached to the switch did not understand the EAP PDU that it received from the switch, it is not able to send an ID and the port remains unauthorized. In this state, the port would never pass any user traffic and would be as good as disabled. If the client PC is running the IEEE 802.1x EAP, it would respond to the request with its configured ID. This could be a user name/password combination or a certificate.

After the switch, the authenticator receives the ID from the PC (the supplicant). The KSZ8775CLX then passes the ID information to an authentication server (RADIUS server) that can verify the identification information. The RADIUS server responds to the switch with either a success or failure message. If the response is successful, the port will be authorized and user traffic will be allowed to pass through the port like any switch port connected to an access device. If the response is a failure, the port will remain unauthorized and, therefore, unused. If there is no response from the server, the port will also remain unauthorized and will not pass any traffic.

### ***Authentication Register and Programming Model***

The port authentication control registers define the control of port-based authentication. The per-port authentication can be programmed in these registers. The KSZ8775CLX provides three modes for implementing the IEEE 802.1x feature. Each mode can be selected by setting the appropriate bits in the port authentication registers.

In pass mode (AUTHENTICATION\_MODE = 00), forced-authorization is enabled and a port is always authorized that does not require any messages from either the supplicant or the authentication server. This is typically the case when connecting to another switch, a router, or a server, and also when connecting to clients that do not support IEEE 802.1x. When ACL is enabled, all the packets are passed if they miss ACL rules; otherwise, ACL actions apply.

The block mode (AUTHENTICATION\_MODE = 01) is the standard port-based authentication mode. A port in this mode sends EAP packets to the supplicant and will not become authorized unless it receives a positive response from the authentication server. Before authentication, traffic is blocked to all of the incoming packets. Upon authentication, software will switch to pass mode to allow all the incoming packets. In this mode, the source address of incoming packets is not checked, including the EAP address. The forwarding map of all the reserved multicast addresses needs to be configured to allow forwarding before and after authentication in the look-up table. When ACL is enabled, packets except ACL hits are blocked.

The third mode is trap mode (AUTHENTICATION\_MODE = 11'b). In this mode, all the packets are sent to CPU port. If ACL is enabled, the missed packets are forwarded to the CPU rather than dropped. All these per-port features can be selected through the Port Control 5 Register; bit [2] is used to enable ACL, bits [1:0] are for the modes selected.

### **Access Control List (ACL) Filtering**

An ACL can be created to perform the protocol-independent Layer 2 MAC, Layer 3 IP, or Layer 4 TCP/UDP ACL filtering that manages incoming Ethernet packets based on the ACL rule table. The feature allows the switch to filter customer traffic based on the source MAC address in the Ethernet header, the IP address in the IP header, and the port number and protocol in the TCP header. This function can be performed through the MAC table and ACL rule table. Besides multicast filtering using entries in the static table, ACLs can be configured for all routed network protocols to filter the packets of those protocols as the packets pass through the switch. Access lists can prevent certain traffic from entering or exiting a network.

### ***Access Control Lists***

The KSZ8775CLX offers a rule-based access control list. The ACL rule table is an ordered list of access control entries. Each entry specifies certain rules (a set of matching conditions and action rules) to permit or deny the packet access to the switch fabric. The meaning of 'permit' or 'deny' depends on the context in which the ACL is used. When a packet is received on an interface, the switch compares the fields in the packet against any applied ACLs to verify that the packet has the permissions required to be forwarded, based on the conditions specified in the lists.

The filter tests the packets against the ACL entries one-by-one. Usually, the first match determines whether the router accepts or rejects packets. However, it is allowed to cascade the rules to form more robust and/or stringent requirements for incoming packets. ACLs allow switch filter ingress traffic based on the source, destination MAC address and Ethernet type in the Layer 2 header, the source and destination IP address in the Layer 3 header, and port number protocol in the Layer 4 header of a packet.

Each list consists of three parts: the matching field, the action field, and the processing field. The matching field specifies the rules that each packet matches against and the action field specifies the action taken if the test succeeds against the rules. [Figure 13](#) shows the format of ACL and a description of the individual fields.

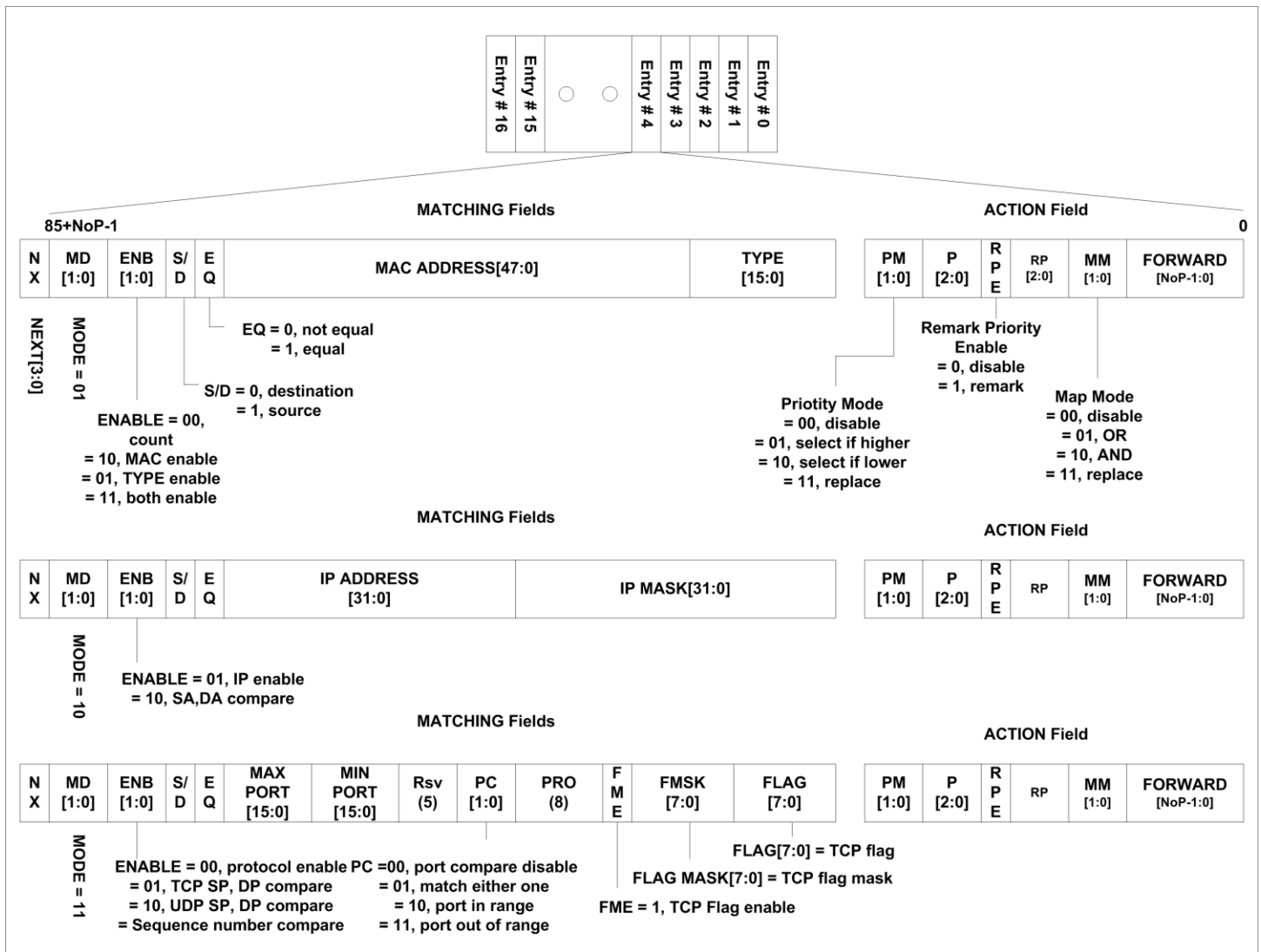

Figure 13. ACL Format

**Matching Fields**

**MD [1:0]:** MODE - there are three modes of operation defined in ACL.

MD = 00 disables the current rule list. No action will be taken.

MD = 01 is qualification rules for Layer 2 MAC header filtering.

MD = 10 is used for Layer 3 IP address filtering.

MD = 11 performs Layer 4 TCP port number/protocol filtering.

**ENB [1:0]:** ENABLE – Enables different rules in the current list.

When MD = 01,

If ENB = 00, the 11 bits of the aggregated bit field from PM, P, RPE, RP, MM in the action field specify a count value for packets matching the MAC address and type in the matching fields.

The count unit is defined in MSB of the forward bit field; while = 0,  $\mu$ sec will be used and while = 1, msec will be used.

The second MSB of the forwarded bit determines the algorithm used to generate an interrupt when the counter terminates. When = 0, an 11-bit counter is loaded with the count value from the ACL and starts counting down every unit

of time. An interrupt is generated when it expires (i.e., the next qualified packet has not been received within the period specified by the value). When = 1, the counter is incremented on every matched packet received and an interrupt is generated when the terminal count reaches the count value in the ACL. The count resets thereafter.

If ENB = 01, the MAC address bit field is used for testing;

If ENB = 10, the MAC type bit field is used for testing;

If ENB = 11, both the MAC address and type are tested against these bit fields in the list.

When MD = 10,

If ENB = 01, the IP address and mask or IP protocol is enabled to be tested accordingly.

If ENB = 10, the source and destination addresses are compared. The drop/forward decision is based on the EQ bit setting.

When MD = 11,

If ENB = 00, protocol comparison is enabled.

If ENB = 01, TCP address comparison is selected.

If ENB = 10, UDP address comparison is selected.

If ENB = 11, the sequence number of the TCP is compared.

**S/D:** Source or destination selection

S/D = 0, the destination address/port is compared;

S/D = 1, the source is chosen.

**E/Q:** comparison algorithm:

E/Q = 0, match if they are not equal;

E/Q = 1, match if they are equal.

**MAC Address [47:0]:** MAC source or destination address

**TYPE [15:0]:** MAC Ether Type

**IP Address [31:0]:** IP source or destination address

**IP Mask [31:0]:** IP address mask for group address filtering

**MAX Port [15:0], MIN Port [15:0] (Sequence Number [31:0]):** The range of TCP port number or sequence number matching.

**PC [1:0]:** Port comparison

PC = 00, the comparison is disabled.

PC = 01, matches either one of MAX or MIN.

PC = 10, match if the port number is in the range of MAX to MIN.

PC = 11, match if the port number is out of the range.

**PRO [7:0]:** IP protocol to be matched

**FME:** Flag match enable

FME = 0, disable TCP FLAG matching.

FME = 1, enable TCP FLAG matching.

**FLAG [5:0]:** TCP flag to be matched.

### **Action Field**

**PM [1:0]:** Priority mode

PM = 00, no priority is selected, the priority is determined by the QoS/classification is used.

PM = 01, the priority in P bit field is used if it is greater than QoS result.

PM = 10, the priority in P bit field is used if it is smaller than QoS result.

PM = 11, the P bit field will replace the priority determined by QoS.

**P [2:0]:** Priority.

**RPE:** Remark priority enable

RPE = 0, no remarking is necessary.

RPE = 1, the VLAN priority bits in the tagged packets are replaced by RP bit field in the list.

**RP [2:0]:** Remarked priority.

**MM [1:0]:** Map mode

MM = 00, no forwarding remapping is necessary.

MM = 01, the forwarding map in FORWARD is OR'ed with the forwarding map from the look-up table.

MM = 10, the forwarding map in FORWARD is AND'ed with the forwarding map from the look-up table.

MM = 11, the forwarding map in FORWARD replaces the Forwarding map from the look-up table.

**FORWARD Bits [4:0]:** Forwarding port(s) - Each bit indicates the forwarding decision of one port.

### ***Processing Field***

**FRN Bits [3:0]:** First rule number – Assigns which entry with its Action Field in 16 entries is used in the rule set.

For the rule set, see description below.

**RULESET Bits [15:0]:** Rule set - Group of rules to be qualified, there are 16 entries rule can be assigned to a rule set per port by the two rule set registers. The rule table allows the rules to be cascaded. There are 16 entries in the RTB. Each entry can be a rule on its own, or can be cascaded with other entries to form a rule set. The test result of incoming packets against rule set will be the AND'ed result of all the test result of incoming packets against the rules included in this rule set. The action of the rule set will be the action of the first rule specified in FRN field. The rule with higher priority will have lower index number. Or rule 0 is the highest priority rule and rule 15 is the lowest priority. ACL rule table entry is disabled when mode bits are set to 2'b00.

A rule set is used to select the match results of different rules against incoming packets. These selected match results will be AND'ed to determine whether the frame matches or not. The conditions of different rule sets having the same action will be OR'ed for comparison with frame fields, and the CPU will program the same action to those rule sets that are to be OR'ed together. For matched rule sets, different rule sets having different actions will be arbitrated or chosen based upon the first rule number (FRN) of each rule set. The rule table will be set up with the high priority rule at the top of the table or with the smaller index. Regardless whether the matched rule sets have the same or different action, the hardware will always compare the first rule number of different rule sets to determine the final rule set and action.

### ***Denial of Service (DoS) Attack Prevention via ACL***

The ACL can provide certain detection/protection of the following DoS attack types based on rule setting, which can be programmed to drop or not to drop each type of DoS packet respectively.

*Example 1:* When MD = '10', ENABLE = '10', setting the EQ bit to '1' can determine the drop or forward packets with identical source and destination IP addresses in IPv4/IPv6.

*Example 2:* When MD = '11', ENABLE = '01'/10', setting the EQ bit to '1' can determine the drop or forward packets with identical source and destination TCP/UDP ports in IPv4/IPv6.

*Example 3:* When MD = '11', ENABLE = '11', Sequence Number = '0', FME = '1', FMSK = '00101001', FLAG = 'xx1x1xx1', Setting the EQ bit to '1' will drop/forward the all packets with a TCP sequence number equal to '0', and flag bit URG = '1', PSH = '1', and FIN = '1'.



*Example 4:* When MD = '11', ENABLE = '01', MAX Port = '1024', MIN Port = '0', FME = '1', FMSK = '00010010', FLAG = 'xxx0xx1x', Setting the EQ bit to '1' will drop/forward the all packets with a TCP port number ≤1024, and flag bit URB = '0', SYN = '1'.

ACL-related registers list as the Register 110 (0x6E), the Register 111 (0x6F), and the ACL rule tables.

## Device Registers

The KSZ8775CLX device has a rich set of registers available to manage the functionality of the device. Access to these registers is via the MIIM or SPI interfaces. The figure below provides a global picture of accessibility via the various interfaces and addressing ranges from the perspective of each interface.

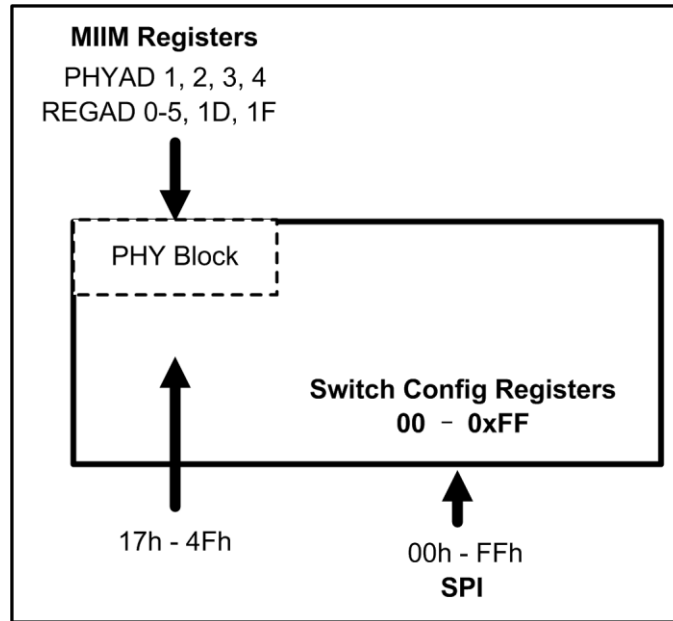

**Figure 14. Interface and Register Mapping**

The registers within the linear 0x00-0xFF address space are all accessible via the SPI interface by a CPU attached to that bus. The mapping of the various functions within that linear address space is summarized in [Table 18](#).

**Table 18. Mapping of Functional Areas within the Address Space**

Register Locations	Device Area	Description
0x00 – 0xFF	Switch Control and Configuration	Registers that control the overall functionality of the switch, MAC, and PHYs.
0x6E – 0x6F	Indirect Control Registers	Registers used to indirectly address and access distinct areas within the device. Management information base (MIB) counters Static MAC address table Dynamic MAC address table VLAN table PME indirect register ACL indirect register EEE indirect Register
0x70 – 0x78	Indirect Access Registers	Registers used to indirectly address and access four distinct areas within the device. Management Information Base (MIB) counters Static MAC address table Dynamic MAC address table VLAN table
0xA0	Indirect Byte Access Registers	This indirect byte register is used to access: PME indirect registers ACL indirect registers EEE indirect registers
0x17 – 0x4F	PHY1 to PHY4 MIIM Registers Mapping to Those Port Registers' Address Ranges	The same PHY registers as specified in IEEE 802.3.

## Direct Register Description

Address	Contents
0x00-0x01	Family ID, Chip ID, Revision ID, and start switch Registers
0x02-0x0D	Global Control Registers 0 – 11
0x0E-0x0F	Global Power Down Management Control Registers
0x10-0x14	Port 1 Control Registers 0 – 4
0x15	Port 1 Authentication Control Register
0x16-0x18	Port 1 Reserved (Factory Test Registers)
0x19-0x1F	Port 1 Control/Status Registers
0x20-0x24	Port 2 Control Registers 0 – 4
0x25	Port 2 Authentication Control Register
0x26-0x28	Port 2 Reserved (Factory Test Registers)
0x29-0x2F	Port 2 Control/Status Registers
0x30-0x34	Port 3 Control Registers 0 – 4
0x35	Port 3 Authentication Control Register
0x36-0x38	Port 3 Reserved (Factory Test Registers)
0x39-0x3F	Port 3 Control/Status Registers
0x40-0x44	Port 4 Control Registers 0 – 4
0x45	Port 4 Authentication Control Register
0x46-0x48	Port 4 Reserved (Factory Test Registers)
0x49-0x4F	Port 4 Control/Status Registers
0x50-0x54	Port 5 Control Registers 0 – 4
0x56-0x58	Port 5 Reserved (Factory Test Registers)
0x59-0x5F	Port 5 Control/Status Registers
0x60-0x67	Reserved (Factory Testing Registers)
0x68-0x6D	MAC Address Registers
0x6E-0x6F	Indirect Access Control Registers
0x70-0x78	Indirect Data Registers
0x79-0x7B	Reserved (Factory Testing Registers)
0x7C-0x7D	Global Interrupt and Mask Registers
0x7E-0x7F	ACL Interrupt Status and Control Registers
0x80-0x87	Global Control Registers 12 – 19
0x88	Switch Self Test Control Register
0x89-0x8F	QM Global Control Registers
0x90-0x9F	Global ToS Priority Control Registers 0 - 15
0xA0	Global Indirect Byte Register
0xA0-0xAF	Reserved (Factory Testing Registers)
0xB0-0xBE	Port 1 Control Registers
0xBF	Reserved (Factory Testing Register): Transmit Queue Remap Base Register
0xC0-0xCE	Port 2 Control Registers

**Direct Register Description (Continued)**

<b>Address</b>	<b>Contents</b>
0xCF	Reserved (Factory Testing Register)
0xD0-0xDE	Port 3 Control Registers
0xDF	Reserved (Factory Testing Register)
0xE0-0xEE	Port 4 Control Registers
0xEF	Reserved (Factory Testing Register)
0xF0-0xFE	Port 5 Control Registers
0xFF	Reserved (Factory Testing Register)

## Global Registers

Address	Name	Description	Mode	Default
<b>Register 0 (0x00): Chip ID0</b>				
7-0	Family ID	Chip family.	RO	0x87
<b>Register 1 (0x01): Chip ID1/Start Switch</b>				
7-4	Chip ID	0x7 for KSZ8775	RO	0x7
3-1	Revision ID		RO	0x0
0	Start Switch	1 = Start the switch function of the chip 0 = Stop the switch function of the chip	R/W	1
<b>Register 2 (0x02): Global Control 0</b>				
7	New back-off enable	New back-off algorithm designed for UNH 1 = Enable 0 = Disable	R/W	0
6	Global soft reset enable	Global Software Reset 1 = Enable reset of all FSM and data path (not configuration) 0 = Disable reset <b>Note:</b> This reset will stop receiving packets if they are in traffic. All registers keep their configuration values.	R/W	0
5	Flush dynamic MAC table	Flush the entire dynamic MAC table for RSTP. This bit is self-clearing (SC). 1 = Trigger the flush dynamic MAC table operation. 0 = Normal operation <b>Note:</b> All the entries associated with a port that has its learning capability turned off (learning disable) will be flushed. If you want to flush the entire table, the learning capability of all ports must be turned off.	R/W (SC)	0
4	Flush static MAC table	Flush the matched entries in static MAC table for RSTP 1 = Trigger the flush static MAC table operation. 0 = Normal operation <b>Note:</b> The matched entry is defined as the entry in the Forwarding Ports field that contains a single port and MAC address with unicast. This port, in turn, has its learning capability turned off (learning disable). Per port, multiple entries can be qualified as matched entries.	R/W (SC)	0
3	Reserved	N/A Don't change.	RO	1
2	Reserved	N/A Don't change.	RO	1
1	UNH Mode	1 = The switch will drop packets with 0x8808 in the T/L filed or DA = 01-80-C2-00-00-01. 0 = The switch will drop packets qualified as flow control packets.	R/W	0
0	Link Change Age	1 = Changing from link to no link will cause the address table to age faster (<800 $\mu$ s). After an age cycle is complete, the age logic will return to normal (300 $\pm$ 75 seconds). <b>Note:</b> If any port is unplugged, all addresses will be automatically aged out.	R/W	0

**Global Registers (Continued)**

Address	Name	Description	Mode	Default
<b>Register 3 (0x03): Global Control 1</b>				
7	Reserved	N/A Don't change.	RO	0
6	2kb packet support	1 = Enable 2kb packet support. 0 = Disable 2kb packet support.	R/W	0
5	IEEE 802.3x Transmit Flow Control Disable	0 = Enables transmit flow control based on AN result. 1 = Will not enable transmit flow control regardless of the AN result.	R/W	0
4	IEEE 802.3x Receive Flow Control Disable	0 = Enables receive flow control based on AN result. 1 = Will not enable receive flow control regardless of the AN result. <b>Note:</b> Bit [5] and bit [4] default values are controlled by the same pin, but they can be programmed independently.	R/W	0
3	Frame Length Field Check	1 = Check frame length field in the IEEE packets. If the actual length does not match, the packet will be dropped (for L/T <1500).	R/W	0
2	Aging Enable	1 = Enable aging function in the chip. 0 = Disable aging function.	R/W	1
1	Fast Aging Enable	1 = Turn on Fast Aging (800 $\mu$ s).	R/W	0
0	Aggressive Back-Off Enable	1 = Enable more aggressive back-off algorithm in half-duplex mode to enhance performance. This is not in the IEEE standard.	R/W	0

**Global Registers (Continued)**

Address	Name	Description	Mode	Default
<b>Register 4 (0x04): Global Control 2</b>				
7	Unicast Port VLAN Mismatch Discard	This feature is used for port VLAN (described in Port Control 1 Register). 1 = All packets can cross VLAN boundary. 0 = Unicast packets (excluding unknown/multicast/broadcast) can cross VLAN boundary. <b>Note:</b> When mirroring is enabled, the single-destination packets will be dropped if it's mirrored to another port.	R/W	1
6	Multicast Storm Protection Disable	1 = Broadcast storm protection does not include multicast packets. Only DA = FFFFFFFF packets will be regulated. 0 = Broadcast storm protection includes DA = FFFFFFFF and DA[40] = 1 packet.	R/W	1
5	Back Pressure Mode	1 = Carrier sense-based back pressure is selected. 0 = Collision-based back pressure is selected.	R/W	1
4	Flow Control and Back Pressure Fair Mode	1 = Fair mode is selected. In this mode, if a flow control port and a non-flow control port talk to the same destination port, then packets from the non-flow control port may be dropped. This is to prevent the flow control port from being controlled for an extended period of time. 0 = In this mode, if a flow control port and a non-flow control port talk to the same destination port, the flow control port will be flow controlled. This may not be fair to the flow control port.	R/W	1
3	No Excessive Collision Drop	1 = The switch will not drop packets when 16 or more collisions occur. 0 = The switch will drop packets when 16 or more collisions occur.	R/W	0
2	Reserved	N/A Don't change.	RO	0
1	Legal Maximum Packet Size Check Disable	1 = Enables acceptance of packet sizes up to 1536 bytes (inclusive). 0 = 1522 bytes for tagged packets (not including packets with STPID from CPU to Ports 1-4), 1518 bytes for untagged packets. Any packets larger than the specified value will be dropped.	R/W	0
0	Reserved	N/A	RO	0

**Global Registers (Continued)**

Address	Name	Description	Mode	Default
<b>Register 5 (0x05): Global Control 3</b>				
7	802.1q VLAN Enable	1 = 802.1q VLAN mode is turned on. VLAN table needs to be set up before the operation. 0 = 802.1q VLAN is disabled.	R/W	0
6	IGMP Snoop Enable on Switch Port 5 SW5-RGMII/MII/RMII Interface	1 = IGMP snoop enabled. All the IGMP packets will be forwarded to the processor via Switch Port 5 RGMII/MII/RMII interface. 0 = IGMP snoop disabled.	R/W	0
5-1	Reserved	N/A Don't change.	RO	00000
0	Sniff Mode Select	1 = Enables RX and TX sniff (both source port and destination port need to match). 0 = Enables RX or TX sniff (either source port or destination port need to match). <b>Note:</b> Default is used to implement RX-only sniff.	R/W	0
<b>Register 6 (0x06): Global Control 4</b>				
7	Switch SW5-MII/RMII Back Pressure Enable	1 = Enable half-duplex back pressure on the switch MII/RMII interface. 0 = Disable back pressure on the switch MII interface.	R/W	0
6	Switch SW5-MII/RMII Half-Duplex Mode	1 = Enable MII/RMII interface half-duplex mode. 0 = Enable MII/RMII interface full-duplex mode.	R/W	0
5	Switch SW5-MII/RMII Flow Control Enable	1 = Enable full-duplex flow control on the switch MII/RMII interface. 0 = Disable full-duplex flow control on the switch MII/RMII interface.	R/W	0
4	Switch SW5-MII/RMII Speed	1 = The switch SW5-MII/RMII is in 10Mbps mode. 0 = The switch SW5-MII/RMII is in 100Mbps mode.	R/W	0
3	Null VID Replacement	1 = Replace null VID with port VID (12 bits). 0 = No replacement for null VID.	R/W	0
2-0	Broadcast Storm Protection Rate Bit[10:8]	This register, along with the next register, determines how many 64-byte blocks of packet data are allowed on an input port in a preset period. The period is 50ms for 100BT or 500ms for 10BT. The default is 1%.	R/W	000
<b>Register 7 (0x07): Global Control 5</b>				
7-0	Broadcast Storm Protection Rate Bits[7:0]	This register, along with the previous register, determines how many 64-byte blocks of packet data are allowed on an input port in a preset period. The period is 50ms for 100BT or 500ms for 10BT. The default is 1%. <b>Note:</b> 148,800 frames/sec × 50ms/interval × 1% = 74 frames/interval (approx.) = 0x4A	R/W	0x4A



**Global Registers (Continued)**

Address	Name	Description	Mode	Default
<b>Register 8 (0x08): Global Control 6 MIB Control</b>				
7	Flush Counter	1 = All the MIB counters of enabled port(s) will be reset to 0. This bit is self-cleared after the operation finishes. 0 = No reset of the MIB counter.	R/W (SC)	0
6	Freeze Counter	1 = Enabled port(s) will stop counting. 0 = Enabled port(s) will not stop counting.	R/W	0
5	Reserved	N/A Don't change.	RO	0
4-0	Control Enable	1 = Enable flush and freeze for each port. Bit [4] is for Port 5 Flush + Freeze. Bit [3] is for Port 4 Flush + Freeze. Bit [2] is for Port 3 Flush + Freeze. Bit [1] is for Port 2 Flush + Freeze. Bit [0] is for Port 1 Flush + Freeze. 0 = Disable flush and freeze.	R/W	0
<b>Register 9 (0x09): Global Control 7</b>				
7-0	Factory Testing	N/A Don't change.	RO	0x40
<b>Register 10 (0x0A): Global Control 8</b>				
7-0	Factory Testing	N/A Don't change	RO	0x00

## Global Registers (Continued)

Address	Name	Description	Mode	Default															
<b>Register 11 (0x0B): Global Control 9</b>																			
7	Reserved	N/A Don't change.	RO	0															
6	Port 5 SW5-RMII Reference Clock Edge Select	Select the data sampling edge of the SW5-RMII reference clock: 1 = Data sampling on the negative edge of REFCLK. 0 = Data sampling on the positive edge of REFCLK (default).	R/W	0															
5-4	LED Mode	<p>Programmable LED output to indicate the port's activity/status using two bits of the control register. LED is ON (active) when the output is LOW; the LED is OFF (inactive) when the output is HIGH.</p> <table border="1"> <thead> <tr> <th>Control Bits [5:4]</th> <th>00</th> <th>01</th> <th>10</th> <th>11</th> </tr> </thead> <tbody> <tr> <td>LEDx_1</td> <td>Speed</td> <td>ACT</td> <td>Duplex</td> <td>Duplex</td> </tr> <tr> <td>LEDx_0</td> <td>Link/ACT</td> <td>Link</td> <td>Link/ACT</td> <td>Link</td> </tr> </tbody> </table> <p>LINK = LED ON; ACT = LED Blink; LINK/ACT = LED ON/Blink.</p> <p>Speed = LED ON (100BT); LED OFF (10BT); LED Blink (1000BT reserved).</p> <p>Duplex = LED ON (full-duplex); LED OFF (half-duplex).</p>	Control Bits [5:4]	00	01	10	11	LEDx_1	Speed	ACT	Duplex	Duplex	LEDx_0	Link/ACT	Link	Link/ACT	Link	R/W	00
Control Bits [5:4]	00	01	10	11															
LEDx_1	Speed	ACT	Duplex	Duplex															
LEDx_0	Link/ACT	Link	Link/ACT	Link															
3	Reserved	N/A Don't change.	RO	0															
2	Reserved	N/A Don't change.	RO	0															
1	REFCLKO Enable	<p>1 = Enable REFCLKO pin clock output 0 = Disable REFCLKO pin clock output.</p> <p>Strap-in option: LED2_0</p> <p>PU = REFCLK_O (25MHz) is enabled. (default) PD = REFCLK_O is disabled</p> <p><b>Note:</b> This is an additional clock and can save an oscillator if the system needs this clock source. If the system doesn't need this clock source, it should be disabled.</p>	R/W	0															
0	SPI Read Sampling Clock Edge Select	Select the SPI clock edge for sampling SPI read data. 1 = Trigger on the rising edge of SPI clock (for higher speed SPI). 0 = Trigger on the falling edge of SPI clock.	R/W	0															

**Global Registers (Continued)**

Address	Name	Description	Mode	Default
<b>Register 12 (0x0C): Global Control 10</b>				
7-6	Reserved	Reserved	RO	01
5-2	Reserved	N/A Don't change	RO	0001
1	Tail Tag Enable	Tail tag feature is applied for Port 5 only. 1 = Insert 1 byte of data right before FCS. 0 = Do not insert.	R/W	0
0	Pass Flow Control Packet	1 = Switch will not filter 802.1x flow control packets. 0 = Switch will filter 802.1x flow control packets.	R/W	0
<b>Register 13 (0x0D): Global Control 11</b>				
7-0	Factory Testing	N/A Don't change	RO	00000000
<b>Register 14 (0x0E): Power-Down Management Control 1</b>				
7-6	Reserved	N/A Don't change	RO	00
5	PLL Power-Down	PLL Power-Down Enable: 1 = Enable 0 = Disable <b>Note:</b> It occurs in the energy detect (EDPD) mode.	R/W	0
4-3	Power Management Mode Select	Power Management Mode: 00 = Normal mode (D0) 01 = Energy Detection mode (D2) 10 = Soft Power-Down mode (D3) 11 = Reserved <b>Note:</b> RC means Read Clear.	R/W (RC)	00
2-0	Reserved	N/A Don't change.	RO	000
<b>Register 15 (0x0F): Power-Down Management Control 2</b>				
7-0	Go_Sleep_Time [7:0]	When the energy detect mode is enabled, this value is used to control the minimum period that the no energy event has to be detected consecutively before the device enters the low power state. The unit is 20ms. The default of go_sleep time is 1.6 seconds (80Dec x 20ms).	R/W	01010000

## Port Registers

The following registers are used to enable features that are assigned on a per port basis. The register bit assignments are the same for all ports, but the address for each port is different, as indicated.

**Register 16 (0x10): Port 1 Control 0**

**Register 32 (0x20): Port 2 Control 0**

**Register 48 (0x30): Port 3 Control 0**

**Register 64 (0x40): Port 4 Control 0**

**Register 80 (0x50): Port 5 Control 0**

Address	Name	Description	Mode	Default
7	Broadcast Storm Protection Enable	1 = Enable broadcast storm protection for ingress packets on the Port. 0 = Disable broadcast storm protection.	R/W	0
6	DiffServ Priority Classification Enable	1 = Enable DiffServ priority classification for ingress packets on port. 0 = Disable DiffServ function.	R/W	0
5	802.1p Priority Classification Enable	1 = Enable 802.1p priority classification for ingress packets on port. 0 = Disable 802.1p priority classification for ingress packets on port.	R/W	0
4 – 3	Port-Based Priority Classification Enable	00 = Ingress packets on port will be classified as priority 0 queue if Diffserv or 802.1p classification is not enabled or fails to classify. 01 = Ingress packets on port will be classified as priority 1 queue if Diffserv or 802.1p classification is not enabled or fails to classify. 10 = Ingress packets on port will be classified as priority 2 queue if Diffserv or 802.1p classification is not enabled or fails to classify. 11 = Ingress packets on port will be classified as priority 3 queue if Diffserv or 802.1p classification is not enabled or fails to classify. <b>Note:</b> DiffServ, 802.1p, and port priority can be enabled at the same time. The OR'ed result of 802.1p and DSCP overwrites the port priority.	R/W	00
2	Tag Insertion	1 = When packets are output on the port, the switch will add 802.1q tags to packets without 802.1q tags when received. The switch will not add tags to packets already tagged. The tag inserted is the ingress port's "Port VID." 0 = Disable tag insertion.	R/W	0
1	Tag Removal	1 = When packets are output on the port, the switch will remove 802.1q tags from packets with 802.1q tags when received. The switch will not modify packets received without tags. 0 = Disable tag removal.	R/W	0

**Port Registers (Continued)**

Address	Name	Description	Mode	Default
0	Two Queues Split Enable	<p>This bit [0] in Registers 16/32/48/64/80 should be in combination with Registers 177/193/209/225/241 bit [1] for Ports 1-5. This will select the split of 1, 2, and 4 queues:</p> <p>For Port 1, Register 177 bit [1], Register 16 bit [0]:</p> <p>11 = Reserved</p> <p>10 = The port output queue is split into four priority queues or if map 802.1p to priority 0-3 mode.</p> <p>01 = The port output queue is split into two priority queues or if map 802.1p to priority 0-3 mode.</p> <p>00 = Single output queue on the port. There is no priority differentiation even though packets are classified into high or low priority.</p>	R/W	0

**Register 17 (0x11): Port 1 Control 1**

**Register 33 (0x21): Port 2 Control 1**

**Register 49 (0x31): Port 3 Control 1**

**Register 65 (0x41): Port 4 Control 1**

**Register 81 (0x51): Port 5 Control 1**

Address	Name	Description	Mode	Default
7	Sniffer Port	<p>1 = Port is designated as sniffer port and will transmit packets that are monitored.</p> <p>0 = Port is a normal port.</p>	R/W	0
6	Receive Sniff	<p>1 = All the packets received on the port will be marked as monitored packets and forwarded to the designated sniffer port.</p> <p>0 = No packets received are monitored.</p>	R/W	0
5	Transmit Sniff	<p>1 = All the packets transmitted on the port will be marked as monitored packets and forwarded to the designated sniffer port.</p> <p>0 = No transmitted packets are monitored.</p>	R/W	0
4-0	Port VLAN Membership	<p>Defines the port's "Port VLAN" membership.</p> <p>Bit [4] stands for Port 5</p> <p>Bit [3] stands for Port 4</p> <p>Bit [2] stands for Port 3</p> <p>Bit [1] stands for Port 2</p> <p>Bit [0] stands for Port 1</p> <p>The port can only communicate within the membership. A '1' includes a port in the membership, a '0' excludes a port in the membership.</p>	R/W	0x1f

**Port Registers (Continued)****Register 18 (0x12): Port 1 Control 2****Register 34 (0x22): Port 2 Control 2****Register 50 (0x32): Port 3 Control 2****Register 66 (0x42): Port 4 Control 2****Register 82 (0x52): Port 5 Control 2**

Address	Name	Description	Mode	Default
7	User Priority Ceiling	1 = If packet's user priority field is greater than the user priority field in the port's default tag register, this replaces the packet's user priority field with the user priority field in the default tag of Port Control 3 Register. 0 = Does not replace packet's priority field with the port default tag priority field of the Port Control 3 Register bits [7:5].	R/W	0
6	Ingress VLAN Filtering.	1 = The switch will discard packets whose VID port membership in VLAN table bits[11:7] does not include the ingress port. 0 = No ingress VLAN filtering.	R/W	0
5	Discard Non-PVID Packets	1 = The switch will discard packets whose VID does not match ingress port default VID. 0 = No packets will be discarded.	R/W	0
4	Force Flow Control	1 = Enables RX and TX flow control on the port, regardless of the AN result. 0 = Flow control is enabled based on the AN result (default) <b>Note:</b> This bit is for Port 1, Port 2, Port 3, and Port 4 SW4-RMII.	R/W	0
3	Back Pressure Enable	1 = Enable port half-duplex back pressure. 0 = Disable port half-duplex back pressure. <b>Note:</b> This bit is for Port 1, Port 2, Port 3, and Port 4 SW4-RMII.	R/W	0
2	Transmit Enable	1 = Enable packet transmission on the port. 0 = Disable packet transmission on the port.	R/W	1
1	Receive Enable	1 = Enable packet reception on the port. 0 = Disable packet reception on the port.	R/W	1
0	Learning Disable	1 = Disable switch address learning capability. 0 = Enable switch address learning.	R/W	0

**Note:** Bits [2:0] are used for spanning tree support. See **Spanning Tree Support** section for more information.

**Port Registers (Continued)****Register 19 (0x13): Port 1 Control 3****Register 35 (0x23): Port 2 Control 3****Register 51 (0x33): Port 3 Control 3****Register 67 (0x43): Port 4 Control 3****Register 83 (0x53): Port 5 Control 3**

Address	Name	Description	Mode	Default
7-0	Default Tag [15:8]	Port's default tag, containing: 7-5: User priority bits 4: CFI bit 3-0: VID[11:8]	R/W	0

**Register 20 (0x14): Port 1 Control 4****Register 36 (0x24): Port 2 Control 4****Register 52 (0x34): Port 3 Control 4****Register 68 (0x44): Port 4 Control 4****Register 84 (0x54): Port 5 Control 4**

Address	Name	Description	Mode	Default
7-0	Default Tag [7:0]	Default Port 1's tag, containing: 7-0: VID[7:0]	R/W	1

Note: Registers 19 and 20 (and those corresponding to other ports) serve two purposes: (1) Associated with the ingress untagged packets, and used for egress tagging; (2) Default VID for the ingress untagged or null-VID-tagged packets and used for address look up.

**Register 21 (0x15): Port 1 Control 5****Register 37 (0x25): Port 2 Control 5****Register 53 (0x35): Port 3 Control 5****Register 69 (0x45): Port 4 Control 5****Register 85 (0x55): Port 5 Control 5**

Address	Name	Description	Mode	Default
7-3	Reserved	N/A Don't change	RO	00000
2	ACL Enable	1 = Enable ACL 0 = Disable ACL	R/W	0
1-0	AUTHENTICATION_MODE	These bits control port-based authentication: 00, 10 = Authentication disable, all traffic is allowed (forced-authorized), if ACL is enabled, pass all traffic if ACL missed 01 = Authentication enabled, all traffic is blocked, if ACL is enabled, traffic is blocked if ACL missed 11 = Authentication enabled, all traffic is trapped to CPU port, if ACL is enabled, traffic is trapped to Port 5 CPU port only if ACL missed.	R/W	00

**Port Registers (Continued)****Register 22 (0x16): Reserved****Register 38 (0x26): Reserved****Register 54 (0x36): Reserved****Register 70 (0x46): Port 4 Interface Control 6****Register 86 (0x56): Port 5 Interface Control 6**

Address	Name	Description	Mode	Default
7	RMII_CLK_SEL	<p>Port 4 and Port 5 RMII Mode Select</p> <p>1 = RMII uses internal clock (clock mode) 0 = RMII uses external clock (normal mode)</p> <p>Strap-in option for Port 5: LED2_1</p> <p>PU = Clock mode in SW5-RMII to provide 50MHz reference clock from RXC5 (default). PD = Normal mode in SW5-RMII to receive 50MHz reference clock from TXC5/REFCLKI5.</p> <p><b>Note:</b> This pin has an internal pull-up.</p> <p>Strap-in option for Port 4: RXD4_0</p> <p>PU = Clock mode in SW4-RMII, using 25MHz OSC clock and provide 50MHz RMII clock from pin RXC4. PD = Normal mode in SW4-RMII, the TXC4/REFCLKI4 pin on the port 4 SW4-RMII will receive an external 50MHz clock (default).</p> <p><b>Note:</b> This pin has an internal pull-down.</p>	R/W	0 - Port 4 1 - Port 5
6	Is_1Gbps	<p>1 = 1Gbps is chosen for Port 5 in RGMII mode. 0 = 10/100Mbps is chosen for Port 5 in RGMII mode.</p> <p>Strap-in option: LED1_0</p> <p>PU = 1Gbps in SW5-RGMII mode (default) PD = 10/100Mbps in SW5-RGMII mode</p> <p><b>Note:</b> This pin has an internal pull-up.</p> <p>Use bit [4] of the Register 6, Global Control 4 to set for 10 or 100 speed in 10/100Mbps mode. This bit is reserved for Port 4.</p>	R/W	1
5	Reserved	N/A Don't change	RO	1
4	RGMII Internal Delay (ID) Ingress Enable	<p>Enable Ingress RGMII ID mode</p> <p>1 = Ingress RGMII-ID enabled. Min. 1.5ns delay is added to ingress clock input 0 = No delay is added, only clock to data skew applied.</p> <p><b>Note:</b> The egress delay of the connection partner should be set to opposite value to match this ingress delay or no delay. This bit is reserved for Port 4.</p>	R/W	0
3	RGMII Internal Delay (ID) Egress Enable	<p>Enable Egress RGMII ID mode</p> <p>1 = Egress RGMII-ID enabled. Min. 1.5ns delay is added to egress clock output 0 = No delay is added, only clock to data skew applied.</p> <p><b>Note:</b> The ingress delay of the connection partner should be set to opposite value to match this egress delay or no delay. This bit is reserved for Port 4.</p>	R/W	1



## Port Registers (Continued)

Address	Name	Description	Mode	Default
2	MII Mode Select	<p>Port 5 SW5-MII Mode Select</p> <p>1 = MII is in MAC mode (default).</p> <p>0 = MII is in PHY mode.</p> <p>Strap-in option: LED2_1</p> <p>PU = MII is in MAC mode. (default)</p> <p>PD = MII is in PHY mode.</p> <p><b>Note:</b> When setting SW5-MII to PHY mode, the CRS, COL, RXC, and TXC pins will change from the input to output.</p> <p>This bit is reserved for Port 4.</p>	R/W	1
1-0	Interface Mode Select	<p>These bits select the interface type and mode for switch Port 5 (SW5).</p> <p>Port 5 Mode Select:</p> <p>00 = MII</p> <p>01 = RMII</p> <p>10 = Reserved</p> <p>11 = RGMII.</p> <p>Strap-in option: LED3[1:0]</p> <p>00 = MII</p> <p>01 = RMII</p> <p>10 = Reserved</p> <p>11 = RGMII (default)</p> <p><b>Note:</b> These pins have internal pull-ups. These bits are reserved for Port 4.</p>	R/W	11

**Port Registers (Continued)****Register 23 (0x17): Port 3 Control 7****Register 39 (0x27): Port 3 Control 7****Register 55 (0x37): Port 3 Control 7****Register 71 (0x47): Reserved****Register 87 (0x57): Reserved**

Address	Name	Description	Mode	Default
7-6	Reserved	N/A Don't change	RO	0000
5-4	Advertised Flow Control Capability	<p>These bits indicate that the KSZ8775CLX has implemented both the optional MAC control sublayer and the PAUSE function as specified in IEEE Clause 31 and Annex 31B for full duplex operation independent of rate and medium.</p> <p>00 = No pause            01 = Symmetric PAUSE            10 = Asymmetric PAUSE toward link partner toward link partner            11 = Both Symmetric PAUSE and Asymmetric PAUSE toward local devices</p> <p>Bit [5] indicates that asymmetric PAUSE is supported. The value of bit [4], when bit [5] is set, indicates the direction of the PAUSE frames that are supported for flow across the link. Asymmetric PAUSE configuration results in independent enabling of the PAUSE receive and PAUSE transmit functions as defined by IEEE Annex 31B.</p>	R/W	11
3	Advertised 100BT Full-Duplex Capability	<p>1 = Advertise 100BT full-duplex capability.            0 = Suppress 100BT full-duplex capability from transmission to link partner.</p>	R/W	1
2	Advertised 100BT Half-Duplex Capability	<p>1 = Advertise 100BT half-duplex capability.            0 = Suppress 100BT half-duplex capability from transmission to link partner.</p>	R/W	1
1	Advertised 10BT Full-Duplex Capability	<p>1 = Advertise 10BT full-duplex capability.            0 = Suppress 10BT full-duplex capability from transmission to link partner.</p>	R/W	1
0	Advertised 10BT Half-Duplex Capability	<p>1 = Advertise 10BT half-duplex capability.            0 = Suppress 10BT half-duplex capability from transmission to link partner.</p>	R/W	1

**Port Registers (Continued)****Register 24 (0x18): Port 1 Status 0****Register 40 (0x28): Port 2 Status 0****Register 56 (0x38): Port 3 Status 0****Register 72 (0x48): Reserved****Register 88 (0x58): Reserved**

Address	Name	Description	Mode	Default
7-6	Reserved	N/A Don't change	RO	0000
5-4	Partner Flow Control Capable	These bits indicate the partner capability for both the optional MAC control sub-layer and the PAUSE function as specified in IEEE Clause 31 and Annex 31B for full duplex operation independent to rate and medium. 00 = No pause 01 = Symmetric PAUSE 10 = Asymmetric PAUSE toward link partner toward link partner 11 = Both Symmetric PAUSE and Asymmetric PAUSE toward local devices	RO	00
3	Partner 100BT Full-Duplex Capability	1 = Link partner 100BT full-duplex capable. 0 = Link partner not 100BT full-duplex capable.	RO	0
2	Partner 100BT Half-Duplex Capability	1 = Link partner 100BT half-duplex capable. 0 = Link partner not 100BT half-duplex capable.	RO	0
1	Partner 10BT Full-Duplex Capability	1 = Link partner 10BT full-duplex capable. 0 = Link partner not 10BT full-duplex capable.	RO	0
0	Partner 10BT Half-Duplex Capability	1 = Link partner 10BT half-duplex capable. 0 = Link partner not 10BT half-duplex capable.	RO	0

**Port Registers (Continued)****Register 25 (0x19): Port 1 Status 1****Register 41 (0x29): Port 2 Status 1****Register 57 (0x39): Port 3 Status 1****Register 73 (0x49): Reserved****Register 89 (0x59): Reserved**

Address	Name	Description	Mode	Default
7	Hp_Mdix	1 = HP Auto MDI/MDI-X Mode 0 = Micrel Auto MDI/MDI-X Mode	R/W	1
6	Factory Testing	N/A Don't change	RO	0
5	Polrvs	1 = Polarity is reversed 0 = Polarity is not reversed	RO	0
4	Transmit Flow Control Enable	1 = Transmit flow control feature is active 0 = Transmit flow control feature is inactive	RO	0
3	Receive Flow Control Enable	1 = Receive flow control feature is active 0 = Receive flow control feature is inactive	RO	0
2	Operation Speed	1 = Link speed is 100Mbps 0 = Link speed is 10Mbps	RO	0
1	Operation Duplex	1 = Link duplex is full 0 = Link duplex is half	RO	0
0	Reserved	N/A Don't change	RO	0

**Port Registers (Continued)****Register 26 (0x1A): Port 1 PHY Control 8****Register 42 (0x2A): Port 2 PHY Control 8****Register 58 (0x3A): Port 3 PHY Control 8****Register 74 (0x4A): Reserved****Register 90 (0x5A): Reserved**

Address	Name	Description	Mode	Default
7	Cable Diagnostic Test (CDT) 10M Short	1 = Less than 10 meter short	RO	0
6-5	CDT_Result	00 = Normal condition 01 = Open condition detected in cable 10 = Short condition detected in cable 11 = Cable diagnostic test has failed	RO	00
4	CDT_Enable	1 = Enable cable diagnostic test. After CDT test has completed, this bit will be self-cleared. 0 = Indicates that the cable diagnostic test (if enabled) has indicated cable diagnostic test.	R/W (SC)	0
3	Force_Link	1 = Force link pass 0 = Normal operation	R/W	0
2	Pwrsave	1 = Enable power saving 0 = Disable power saving	R/W	0
1	Remote Loopback	1 = Perform Remote loopback, loopback on Port 1 as follows: Port 1 (Register 26, bit [1] = '1') Start: RXP1/RXM1 (Port 1) Loopback: PMD/PMA of Port 1's PHY End: TXP1/TXM1 (Port 1) Setting Register 42, 58, 74 bit [1] = '1' will perform remote loopback on Port 2, 3, 4. 0 = Normal Operation.	R/W	0
0	CDT_Fault_Count[8]	Bit[8] of CDT fault count Distance to the fault. It is approximately 0.4 × CDT_Fault_Count[8:0].	RO	0

**Register 27 (0x1B): Port 1 LinkMD result****Register 43 (0x2B): Port 2 LinkMD result****Register 59 (0x3B): Port 3 LinkMD result****Register 75 (0x4B): Reserved****Register 91 (0x5B): Reserved**

Address	Name	Description	Mode	Default
7-0	CDT_Fault_Count[7:0]	Bits[7:0] of CDT fault count Distance to the fault. It is approximately 0.4m × CDT_Fault_Count[8:0]	RO	0

**Port Registers (Continued)****Register 28 (0x1C): Port 1 Control 9****Register 44 (0x2C): Port 2 Control 9****Register 60 (0x3C): Port 3 Control 9****Register 76 (0x4C): Port 4 Control 9****Register 92 (0x5C): Reserved**

Address	Name	Description	Mode	Default
7	Disable Auto-Negotiation	1 = Disable auto-negotiation. Speed and duplex are decided by bits [6:5] of the same register. 0 = Auto-negotiation is on. <b>Note:</b> This bit shouldn't be used for Port 4 SW4-RMII.	R/W	0
6	Forced Speed	1 = Forced 100BT if auto-negotiation is disabled (bit [7]). 0 = Forced 10BT if auto-negotiation is disabled (bit [7]). <b>Note:</b> This bit is for Port 1, Port 2, Port 3, and Port 4 SW4-RMII.	R/W	1
5	Forced Duplex	1 = Forced full-duplex if (1) AN is disabled or (2) AN is enabled but failed. 0 = Forced half-duplex if (1) AN is disabled or (2) AN is enabled but failed (default). <b>Note:</b> This bit is for Port 1, Port 2, Port 3, and Port 4 SW4-RMII.	R/W	0
4-0	Reserved	N/A Don't change	RO	0x1f

**Port Registers (Continued)****Register 29 (0x1D): Port 1 Control 10****Register 45 (0x2D): Port 2 Control 10****Register 61 (0x3D): Port 3 Control 10****Register 77 (0x4D): Port 4 Control 10****Register 93 (0x5D): Reserved**

Address	Name	Description	Mode	Default
7	LED Off	1 = Turn off all Ports' LEDs (LEDx_2, LEDx_1, LEDx_0 pins, where "x" is the port number). These pins will be driven high if this bit is set to '1'. 0 = Normal operation.	R/W	0
6	Txids	1 = Disable port's transmitter. 0 = Normal operation.	R/W	0
5	Restart AN	1 = Restart auto-negotiation. 0 = Normal operation.	R/W (SC)	0
4	Reserved	N/A Don't change	RO	0
3	Power Down	1 = Power down. 0 = Normal operation.	R/W	0
2	Disable Auto MDI/MDI-X	1 = Disable Auto-MDI/MDIX function. 0 = Enable Auto-MDI/MDIX function.	R/W	0
1	Forced MDI	1 = If Auto-MDI/MDIX is disabled, force PHY into MDI mode. 0 = MDI-X mode.	R/W	0
0	MAC Loopback	1 = Perform MAC loopback. Loopback path is as follows: (e.g., set Port 1 MAC Loopback (Reg. 29, bit [0] = '1'), use Port 2 as monitor port. The packets will transfer. Start: Port 2 receiving (also can start to receive packets from Port 3, 4, 5). Loopback: Port 1's MAC. End: Port 2 transmitting (also can end at Port 3, 4, 5 respectively). Setting Register 45, 61, 77, 93, bit [0] = '1' will perform MAC loopback on Port 2, 3, 4, 5 respectively. 0 = Normal Operation. <b>Note:</b> Bit[0] MAC loopback supports Port 1 through Port 5. Other bits support Port 1 through Port 3.	R/W	0

**Port Registers (Continued)****Register 30 (0x1E): Port 1 Status 2****Register 46 (0x2E): Port 2 Status 2****Register 62 (0x3E): Port 3 Status 2****Register 78 (0x4E): Reserved****Register 94 (0x5E): Reserved**

Address	Name	Description	Mode	Default
7	MDIX Status	1 = MDI. 0 = MDI-X.	RO	0
6	Auto-Negotiation Done	1 = Auto-Negotiation done. 0 = Auto-Negotiation not done.	RO	0
5	Link Good	1 = Link good. 0 = Link not good.	RO	0
4-0	Reserved	N/A Don't change	RO	00000

**Register 31 (0x1F): Port 1 Control 11 and Status 3****Register 47 (0x2F): Port 2 Control 11 and Status 3****Register 63 (0x3F): Port 3 Control 11 and Status 3****Register 79 (0x4F): Reserved****Register 95 (0x5F): Reserved**

Address	Name	Description	Mode	Default
7	PHY Loopback	1 = Perform PHY loopback. Loopback path is as follows. Example: Set Port 1 PHY Loopback (Reg. 31, bit [7] = '1') Use Port 2 as monitor port. The packets will transfer. Start: Port 2 receiving (also can start from Port 3, 4, 5). Loopback: PMD/PMA of Port 1's PHY End: Port 2 transmitting (also can end at Port 3, 4, 5 respectively). Setting Register 47, 63, 79, 95, bit [7] = '1' will perform PHY loopback on Port 2, 3, 4, 5 respectively. 0 = Normal operation.	R/W	0
6	Reserved	N/A Don't change	RO	0
5	PHY Isolate	1 = Electrical isolation of PHY from the internal MII and TX+/TX-. 0 = Normal operation.	R/W	0
4	Soft-Reset	1 = PHY soft-reset. This bit is self-clearing. 0 = Normal operation.	R/W (SC)	0



**Port Registers (Continued)**

Address	Name	Description	Mode	Default
3	Force Link	1 = Force link in the PHY. 0 = Normal operation	R/W	0
2-0	Port Operation Mode Indication	Indicate the current state of port operation mode: 000 = Reserved 001 = Still in Auto-Negotiation 010 = 10BASE-T half-duplex 011 = 100BASE-TX half-duplex 100 = Reserved 101 = 10BASE-T full-duplex 110 = 100BASE-TX full-duplex 111 = Reserved	RO	001

Note: Port Control 7-11 and Port Status 1-3 contents can be accessed by MDC/MDIO interface via the standard MIIM registers.

**Advanced Control Registers**

Registers 104 to 109 define the switching engine's MAC address. This 48-bit address is used as the source address in MAC pause control frames.

Address	Name	Description	Mode	Default
<b>Register 104 (0x68): MAC Address Register 0</b>				
7-0	MACA[47:40]		R/W	0x00
<b>Register 105 (0x69): MAC Address Register 1</b>				
7-0	MACA[39:32]		R/W	0x10
<b>Register 106 (0x6A): MAC Address Register 2</b>				
7-0	MACA[31:24]		R/W	0xA1
<b>Register 107 (0x6B): MAC Address Register 3</b>				
7-0	MACA[23:16]		R/W	0xff
<b>Register 108 (0x6C): MAC Address Register 4</b>				
7-0	MACA[15:8]		R/W	0xff
<b>Register 109 (0x6D): MAC Address Register 5</b>				
7-0	MACA[7:0]		R/W	0xff

**Advanced Control Registers (Continued)**

Use Registers 110 and 111 to read or write data to the static MAC address table, VLAN table, dynamic address table, PME registers, ACL tables, EEE registers, and the MIB counters.

Address	Name	Description	Mode	Default
<b>Register 110 (0x6E): Indirect Access Control 0</b>				
7-5	EEE/ACL/PME Indirect Register Function Select	<p>000 = Indirect mode is used for table select in bits [3:2]. While these bits are not equal 000, bits [3:2] are used for 2 additional MSB address bits.</p> <p>001 = Global and port-based EEE registers are selected, port count is specified in 4 MSB indirect address bits and 8 bits register pointer is specified in 8 LSB indirect address bits.</p> <p>010 = Port-based ACL registers are selected, port count is specified in 4 MSB indirect address bits and register pointer is specified in 8 LSB indirect address bits.</p> <p>011 = Reserved</p> <p>100 = PME control registers are selected.</p> <p>101 = LinkMD cable diagnosis used. (See example in LinkMD section).</p>	R/W	000
4	Read High Write Low	<p>1 = Read cycle.</p> <p>0 = Write cycle.</p>	R/W	0
3-2	Table Select or Indirect Address [11:10]	<p>If bits [6:5] = 00, then</p> <p>00 = Static MAC Address Table selected.</p> <p>01 = VLAN table selected.</p> <p>10 = Dynamic Address Table selected.</p> <p>11 = MIB Counter selected.</p> <p>If bits [6:5] not equal 00, then these are indirect address [11:10] that is MSB of indirect address, bits [11:8] of the indirect address may be served as port address, and bits [7:0] as register address.</p> <p><b>Note:</b> The Register 110 bits[3:0] are used for the indirect address bits [11:8] 4 MSB bits, the 4 bits are used for the port indirect registers as well.</p> <p>0000 = Global indirect registers            0001 = Port 1 indirect registers            0010 = Port 2 indirect registers            0011 = Port 3 indirect registers            0100 = Port 4 indirect registers            0101 = Port 5 indirect registers</p> <p>The Register 111 bits[7:0] are used for the indirect address bits of 8 LSB for indirect register address spacing.</p>	R/W	0
1-0	Indirect Address [9:8]	Bits [9:8] of indirect address.	R/W	00
<b>Register 111 (0x6F): Indirect Access Control 1</b>				
7-0	Indirect Address [7:0]	Bits [7:0] of indirect address.	R/W	00000000

**Note:** Write to Register 111 will actually trigger a command. Read or write access is decided by bit [4] of Register 110.

**Advanced Control Registers (Continued)**

The following Indirect Data Registers 112-120 are used for table of static, VLAN, dynamic table, PME, EEE, ACL, and MIB counters.

Address	Name	Description	Mode	Default
<b>Register 112 (0x70): Indirect Data Register 8</b>				
7-0	Indirect Data [68:64]	Bits [68:64] of indirect data.	R/W	00000000
<b>Register 113 (0x71): Indirect Data Register 7</b>				
7-0	Indirect Data [63:56]	Bits [63:56] of indirect data.	R/W	00000000
<b>Register 114 (0x72): Indirect Data Register 6</b>				
7-0	Indirect Data [55:48]	Bits [55:48] of indirect data.	R/W	00000000
<b>Register 115 (0x73): Indirect Data Register 5</b>				
47-40	Indirect Data [47:40]	Bits [47:40] of indirect data.	R/W	00000000
<b>Register 116 (0x74): Indirect Data Register 4</b>				
7-0	Indirect Data [39:32]	Bits [39:32] of indirect data.	R/W	00000000
<b>Register 117 (0x75): Indirect Data Register 3</b>				
7-0	Indirect Data [31:24]	Bits [31:24] of indirect data	R/W	00000000
<b>Register 118 (0x76): Indirect Data Register 2</b>				
7-0	Indirect Data [23:16]	Bits [23:16] of indirect data.	R/W	00000000
<b>Register 119 (0x77): Indirect Data Register 1</b>				
7-0	Indirect Data [15:8]	Bits [15:8] of indirect data.	R/W	00000000
<b>Register 120 (0x78): Indirect Data Register 0</b>				
7-0	Indirect Data [7:0]	Bits [7:0] of indirect data.	R/W	00000000

The named indirect byte registers are direct registers that are used for PME/ACL/EEE indirect register access only. The Indirect Byte Register 160 (0xA0) is used for read/write to all PME, EEE, and ACL indirect registers.

Address	Name	Description	Mode	Default
<b>Register 160 (0xA0): Indirect Byte Register (For PME, EEE, and ACL Registers)</b>				
7-0	Indirect Byte [7:0]	Byte data of indirect access.	R/W	00000000

**Advanced Control Registers (Continued)**

Address	Name	Description	Mode	Default
<b>Register 124 (0x7C): Interrupt Status Register</b>				
7-5	Reserved	N/A Don't change	RO	000
4	PME Interrupt Status	1 = PME interrupt request 0 = Normal <b>Note:</b> This bit reflects PME control registers, write to PME control register to clear <b>Note:</b> This bit is set when PME is asserted. Write a "1" to clear this bit (WC)	RO	0
3	Port 4 Interrupt Status	1 = Port 4 interrupt request 0 = Normal <b>Note:</b> This bit is set by Port 4 link change. Write a "1" to clear this bit (WC)	R/WC	0
2	Port 3 Interrupt Status	1 = Port 3 interrupt request 0 = Normal <b>Note:</b> This bit is set by a link change on Port 3. Write a "1" to clear this bit (WC)	R/WC	0
1	Port 2 Interrupt Status	1 = Port 2 interrupt request 0 = Normal <b>Note:</b> This bit is set by a link change on Port 2. Write a "1" to clear this bit (WC)	R/WC	0
0	Port 1 Interrupt Status	1 = Port 1 interrupt request 0 = Normal <b>Note:</b> This bit is set by link change on Port 1. Write a "1" to clear this bit (WC)	R/WC	0
<b>Register 125 (0x7D): Interrupt Mask Register</b>				
7-5	Reserved	N/A Don't change	RO	000
4	PME Interrupt Mask	1 = Enable PME interrupt. 0 = Normal	R/W	0
3	Port 4 Interrupt Mask	1 = Enable Port 4 interrupt. 0 = Normal	R/W	0
2	Port 3 Interrupt Mask	1 = Enable Port 3 interrupt. 0 = Normal	R/W	0
1	Port 2 Interrupt Mask	1 = Enable Port 2 interrupt. 0 = Normal	R/W	0
0	Port 1 Interrupt Mask	1 = Enable Port 1 interrupt. 0 = Normal	R/W	0

**Advanced Control Registers (Continued)**

<b>Register 126 (0x7E): ACL Interrupt Status Register</b>				
7-5	Reserved	N/A Don't change	RO	000
4-0	ACL_INT_STATUS	ACL Interrupt Status, one bit per port 1 = ACL interrupt detected. 0 = No ACL interrupt detected.	RO	00000
<b>Register 127 (0x7F): ACL Interrupt Control Register</b>				
7-5	Reserved	N/A Don't change	RO	000
4-0	ACL_INT_ENABLE	ACL Interrupt Enable, one bit per port 1 = ACL interrupt enabled. 0 = ACL interrupt disabled.	R/W	0

The Registers 128 and 129 can be used to map from 802.1p priority field 0-7 to the switch's four priority queues 0-3. 0x3 is the highest priority queue, as priority 3, and 0x0 is the lowest priority queues, as priority 0.

Address	Name	Description	Mode	Default
<b>Register 128 (0x80): Global Control 12</b>				
7-6	Tag_0x3	IEEE 802.1p mapping. The value in this field is used as the frame's priority when its IEEE 802.1p tag has a value of 0x3.	R/W	0x1
5-4	Tag_0x2	IEEE 802.1p mapping. The value in this field is used as the frame's priority when its IEEE 802.1p tag has a value of 0x2.	R/W	0x1
3-2	Tag_0x1	IEEE 802.1p mapping. The value in this field is used as the frame's priority when its IEEE 802.1p tag has a value of 0x1.	R/W	0x0
1-0	Tag_0x0	IEEE 802.1p mapping. The value in this field is used as the frame's priority when its IEEE 802.1p tag has a value of 0x0.	R/W	0x0
<b>Register 129 (0x81): Global Control 13</b>				
7-6	Tag_0x7	IEEE 802.1p mapping. The value in this field is used as the frame's priority when its IEEE 802.1p tag has a value of 0x7.	R/W	0x3
5-4	Tag_0x6	IEEE 802.1p mapping. The value in this field is used as the frame's priority when its IEEE 802.1p tag has a value of 0x6.	R/W	0x3
3-2	Tag_0x5	IEEE 802.1p mapping. The value in this field is used as the frame's priority when its IEEE 802.1p tag has a value of 0x5.	R/W	0x2
1-0	Tag_0x4	IEEE 802.1p mapping. The value in this field is used as the frame's priority when its IEEE 802.1p tag has a value of 0x4.	R/W	0x2

**Advanced Control Registers (Continued)**

Address	Name	Description	Mode	Default
<b>Register 130 (0x82): Global Control 14</b>				
7-6	Pri_2Q[1:0]	<p>When the 2 Queues configuration is selected, these Pri_2Q[1:0] bits are used to map the 2-bit result of IEEE 802.1p from Register 128/129 or TOS/DiffServ from Register 144-159 mapping (for 4 Queues) into two queues low/high priorities.</p> <p>2-bit result of IEEE 802.1p or ToS/DiffServ            00 (0) = Map to low priority queue            01 (1) = Prio_2Q[0] map to low/high priority queue            10 (2) = Prio_2Q[1] map to low/high priority queue            11 (3) = Map to high priority queue</p> <p>Pri_2Q[1:0] :            00 = Result 0,1, 2 are low priority. 3 is high priority.            01 = Not supported and should be avoided            10 = Result 0,1 are low priority. 2, 3 are high priority (default).            11 = Result 0 is low priority. 1, 2, 3 are high priority.</p>	R/W	10
5-0	Reserved	N/A Don't change	RO	001000
<b>Register 131 (0x83): Global Control 15</b>				
7-6	Reserved	N/A Don't change	RO	10
5	Unknown Unicast Packet Forward	1 = Enable supporting unknown unicast packet forward 0 = Disable	R/W	0
4-0	Unknown Unicast Packet Forward Port Map	00000 = Filter unknown unicast packet 00001 = Forward unknown unicast packet to Port 1 00011 = Forward unknown unicast packet to Port 1, Port 2 00111 = Forward unknown unicast packet to Port 1, Port 2, and Port 3 01111 = Forward unknown unicast packet to Port 1, Port 2, Port 3, and Port 4 11111 = Broadcast unknown unicast packet to all ports	R/W	00000

**Advanced Control Registers (Continued)**

Address	Name	Description	Mode	Default
<b>Register 132 (0x84): Global Control 16</b>				
7-6	Reserved	N/A Don't change	RO	01
5	Unknown Multicast Packet Forward (not including IP multicast packet)	1 = Enable supporting unknown multicast packet forward 0 = Disable	R/W	0
4-0	Unknown Multicast Packet Forward Port Map	00000 = Filter unknown multiicast packet 00001 = Forward unknown multicast packet to Port 1 00011 = Forward unknown multicast packet to Port 1, Port 2 00111 = Forward unknown multicast packet to Port 1, Port 2, and Port 3 01111 = Forward unknown multicast packet to Port 1, Port 2, Port 3 and, Port 4 11111 = Broadcast unknown multicast packet to all ports	R/W	00000
<b>Register 133(0x85): Global Control 17</b>				
7-6	Reserved	N/A Don't change	RO	00
5	Unknown VID Packet Forward	1 = Enable supporting unknown VID packet forward 0 = Disable	R/W	0
4-0	Unknown VID Packet Forward Port Map	00000 = Filter unknown VID packet 00001 = Forward unknown VID packet to Port 1 00011 = Forward unknown VID packet to Port 1, Port 2 00111 = Forward unknown VID packet to Port 1, Port 2, and Port 3 01111 = Forward unknown VID packet to Port 1, Port 2, Port 3, and Port 4 11111 = Broadcast unknown VID packet to all ports	R/W	00000

**Advanced Control Registers (Continued)**

Address	Name	Description	Mode	Default
<b>Register 134 (0x86): Global Control 18</b>				
7	Reserved	N/A Don't change	RO	0
6	Self-Address Filter Enable	1 = Enable filtering of self-address unicast and multicast packet 0 = Do not filter self-address packet <b>Note:</b> The self-address filtering will filter packets on the egress port, self MAC address is assigned in the Register 104-109.	R/W	0
5	Unknown IP Multicast Packet Forward	1 = Enable supporting unknown IP multicast packet forward 0 = Disable supporting unknown IP multicast packet forward	R/W	0
4-0	Unknown IP Multicast Packet Forward Port Map	00000 = Filter unknown IP multiicast packet 00001 = Forward unknown IP multicast packet to Port 1 00011 = Forward unknown IP multicast packet to Port 1, Port 2 00111 = Forward unknown IP multicast packet to Port 1, Port 2, and Port 3 01111 = Forward unknown IP multicast packet to Port 1, Port 2, Port 3, and Port 4 11111 = Broadcast unknown IP multicast packet to all ports	R/W	00000
<b>Register 135 (0x87): Global Control 19</b>				
7-6	Reserved	N/A Don't change	RO	00
5-4	Ingress Rate Limit Period	The unit period for calculating ingress rate limit 00 = 16ms 01 = 64ms 1x = 256ms	R/W	01
3	Queue-based Egress Rate Limit Enabled	Enable queue-based egress rate limit 0 = Port-based egress rate limit (default) 1 = Queue-based egress rate limit	R/W	0
2	Insertion Source Port PVID Tag Selection Enable	1 = Enable source port PVID tag insertion or non-insertion option on the egress port for each source port PVID based on the Port Control 8 Registers. 0 = Disable, all packets from any ingress port will be inserted PVID based on Port Control 0 Register bit [2].	R/W	0
1-0	Reserved	N/A Don't change	RO	00
<b>Register 144 (0x90): ToS Priority Control Register 0</b>				
The IPv4/IPv6 ToS priority control registers implement a fully decoded 64-bit differentiated services code point (DSCP) register used to determine priority from the 6-bit ToS field in the IP header. The most significant six bits of the ToS field are fully decoded into 64 possibilities and the singular code that results is mapped to the value in the corresponding bit in the DSCP register.				



7-6	DSCP[7:6]	IPv4 and IPv6 mapping The value in this field is used as the frame's priority when bits [7:2] of the frame's IP OS/DiffServ/Traffic Class value is 0x03.	R/W	00
-----	-----------	---	-----	----

**Advanced Control Registers (Continued)**

Address	Name	Description	Mode	Default
5-4	DSCP[5:4]	IPv4 and IPv6 mapping The value in this field is used as the frame's priority when bits [7:2] of the frame's IP OS/DiffServ/Traffic Class value is 0x02.	R/W	00
3-2	DSCP[3:2]	IPv4 and IPv6 mapping The value in this field is used as the frame's priority when bits [7:2] of the frame's IP OS/DiffServ/Traffic Class value is 0x01.	R/W	00
1-0	DSCP[1:0]	IPv4 and IPv6 mapping The value in this field is used as the frame's priority when bits [7:2] of the frame's IP OS/DiffServ/Traffic Class value is 0x00.	R/W	00
<b>Register 145 (0x91): ToS Priority Control Register 1</b>				
7-6	DSCP[15:14]	IPv4 and IPv6 mapping for value 0x07	R/W	00
5-4	DSCP[13:12]	IPv4 and IPv6 mapping for value 0x06	R/W	00
3-2	DSCP[11:10]	IPv4 and IPv6 mapping for value 0x05	R/W	00
1-0	DSCP[9:8]	IPv4 and IPv6 mapping for value 0x04	R/W	00
<b>Register 146 (0x92): ToS Priority Control Register 2</b>				
7-6	DSCP[23:22]	IPv4 and IPv6 mapping for value 0x0B	R/W	00
5-4	DSCP[21:20]	IPv4 and IPv6 mapping for value 0x0A	R/W	00
3-2	DSCP[19:18]	IPv4 and IPv6 mapping for value 0x09	R/W	00
1-0	DSCP[17:16]	IPv4 and IPv6 mapping for value 0x08	R/W	00
<b>Register 147 (0x93): ToS Priority Control Register 3</b>				
7-6	DSCP[31:30]	IPv4 and IPv6 mapping for value 0x0F	R/W	00
5-4	DSCP[29:28]	IPv4 and IPv6 mapping for value 0x0E	R/W	00
3-2	DSCP[27:26]	IPv4 and IPv6 mapping for value 0x0D	R/W	00
1-0	DSCP[25:24]	IPv4 and IPv6 mapping for value 0x0C	R/W	00
<b>Register 148 (0x94): ToS Priority Control Register 4</b>				
7-6	DSCP[39:38]	IPv4 and IPv6 mapping for value 0x13	R/W	00
5-4	DSCP[37:36]	IPv4 and IPv6 mapping for value 0x12	R/W	00
3-2	DSCP[35:34]	IPv4 and IPv6 mapping for value 0x11	R/W	00
1-0	DSCP[33:32]	IPv4 and IPv6 mapping for value 0x10	R/W	00
<b>Register 149 (0x95): ToS Priority Control Register 5</b>				
7-6	DSCP[47:46]	IPv4 and IPv6 mapping for value 0x17	R/W	00
5-4	DSCP[45:44]	IPv4 and IPv6 mapping for value 0x16	R/W	00
3-2	DSCP[43:42]	IPv4 and IPv6 mapping for value 0x15	R/W	00
1-0	DSCP[41:40]	IPv4 and IPv6 mapping for value 0x14	R/W	00
<b>Register 150 (0x96): ToS Priority Control Register 6</b>				
7-6	DSCP[55:54]	IPv4 and IPv6 mapping for value 0x1B	R/W	00
5-4	DSCP[53:52]	IPv4 and IPv6 mapping for value 0x1A	R/W	00

**Advanced Control Registers (Continued)**

Address	Name	Description	Mode	Default
3–2	DSCP[51:50]	IPv4 and IPv6 mapping for value 0x19	R/W	00
1–0	DSCP[49:48]	IPv4 and IPv6 mapping for value 0x18	R/W	00
<b>Register 151 (0x97): ToS Priority Control Register 7</b>				
7–6	DSCP[63:62]	IPv4 and IPv6 mapping for value 0x1F	R/W	00
5–4	DSCP[61:60]	IPv4 and IPv6 mapping for value 0x1E	R/W	00
3–2	DSCP[59:58]	IPv4 and IPv6 mapping for value 0x1D	R/W	00
1–0	DSCP[57:56]	IPv4 and IPv6 mapping for value 0x1C	R/W	00
<b>Register 152 (0x98): ToS Priority Control Register 8</b>				
7–6	DSCP[71:70]	IPv4 and IPv6 mapping for value 0x23	R/W	00
5–4	DSCP[69:68]	IPv4 and IPv6 mapping for value 0x22	R/W	00
3–2	DSCP[67:66]	IPv4 and IPv6 mapping for value 0x21	R/W	00
1–0	DSCP[65:64]	IPv4 and IPv6 mapping for value 0x20	R/W	00
<b>Register 153 (0x99): ToS Priority Control Register 9</b>				
7–6	DSCP[79:78]	IPv4 and IPv6 mapping for value 0x27	R/W	00
5–4	DSCP[77:76]	IPv4 and IPv6 mapping for value 0x26	R/W	00
3–2	DSCP[75:74]	IPv4 and IPv6 mapping for value 0x25	R/W	00
1–0	DSCP[73:72]	IPv4 and IPv6 mapping for value 0x24	R/W	00
<b>Register 154 (0x9A): ToS Priority Control Register 10</b>				
7–6	DSCP[87:86]	IPv4 and IPv6 mapping for value 0x2B	R/W	00
5–4	DSCP[85:84]	IPv4 and IPv6 mapping for value 0x2A	R/W	00
3–2	DSCP[83:82]	IPv4 and IPv6 mapping for value 0x29	R/W	00
1–0	DSCP[81:80]	IPv4 and IPv6 mapping for value 0x28	R/W	00
<b>Register 155 (0x9B): ToS Priority Control Register 11</b>				
7–6	DSCP[95:94]	IPv4 and IPv6 mapping for value 0x2F	R/W	00
5–4	DSCP[93:92]	IPv4 and IPv6 mapping for value 0x2E	R/W	00
3–2	DSCP[91:90]	IPv4 and IPv6 mapping for value 0x2D	R/W	00
1–0	DSCP[89:88]	IPv4 and IPv6 mapping for value 0x2C	R/W	00
<b>Register 156 (0x9C): ToS Priority Control Register 12</b>				
7–6	DSCP[103:102]	IPv4 and IPv6 mapping for value 0x33	R/W	00
5–4	DSCP[101:100]	IPv4 and IPv6 mapping for value 0x32	R/W	00
3–2	DSCP[99:98]	IPv4 and IPv6 mapping for value 0x31	R/W	00
1–0	DSCP[97:96]	IPv4 and IPv6 mapping for value 0x30	R/W	00

**Advanced Control Registers (Continued)**

Address	Name	Description	Mode	Default
<b>Register 157 (0x9D): ToS Priority Control Register 13</b>				
7–6	DSCP[111:110]	IPv4 and IPv6 mapping for value 0x37	R/W	00
5–4	DSCP[109:108]	IPv4 and IPv6 mapping for value 0x36	R/W	00
3–2	DSCP[107:106]	IPv4 and IPv6 mapping for value 0x35	R/W	00
1–0	DSCP[105:104]	IPv4 and IPv6 mapping for value 0x34	R/W	00
<b>Register 158 (0x9E): ToS Priority Control Register 14</b>				
7–6	DSCP[119:118]	IPv4 and IPv6 mapping for value 0x3B	R/W	00
5–4	DSCP[117:116]	IPv4 and IPv6 mapping for value 0x3A	R/W	00
3–2	DSCP[115:114]	IPv4 and IPv6 mapping for value 0x39	R/W	00
1–0	DSCP[113:112]	IPv4 and IPv6 mapping for value 0x38	R/W	00
<b>Register 159 (0x9F): ToS Priority Control Register 15</b>				
7–6	DSCP[127:126]	IPv4 and IPv6 mapping for value 0x3F	R/W	00
5–4	DSCP[125:124]	IPv4 and IPv6 mapping for value 0x3E	R/W	00
3–2	DSCP[123:122]	IPv4 and IPv6 mapping for value 0x3D	R/W	00
1–0	DSCP[121:120]	IPv4 and IPv6 mapping for value 0x3C	R/W	00

**Advanced Control Registers (Continued)**

Address	Name	Description	Mode	Default
<b>Register 163 (0XA3): Global Control 20</b>				
7	Reserved	N/A Don't change	RO	0
6–4	RGMII High Speed Drive Strength	High speed interfaces drive strength for RGMII 000 = 2mA 001 = 4mA 010 = 8mA 011 = 12mA 100 = 16mA 101 = 20mA 110 = 24mA (default) 111 = 28mA	R/W	110
3	Reserved	N/A Don't change	RO	0
2–0	MII/RMII Low Speed Drive Strength	Low speed interfaces drive strength for MII & RMII 000 = 2mA 001 = 4mA 010 = 8mA (default) 011 = 12mA 100 = 16mA 101 = 20mA 110 = 24mA 111 = 28mA	R/W	010
<b>Register 164 (0XA4): Global Control 21</b>				
7–4	Reserved	N/A Don't change	RO	0x2
3	IPv6 MLD Snooping Option	IPv6 MLD snooping option 1 = Enable 0 = Disable	R/W	0
2	IPv6 MLD Snooping Enable	IPv6 MLD snooping enable 1 = Enable 0 = Disable	R/W	0
1–0	Reserved	N/A Don't change	RO	10

**Advanced Control Registers (Continued)**

Address	Name	Description	Mode	Default
<b>Register 176 (0xB0): Port 1 Control 12</b> <b>Register 192 (0xC0): Port 2 Control 12</b> <b>Register 208 (0xD0): Port 3 Control 12</b> <b>Register 224 (0xE0): Port 4 Control 12</b> <b>Register 240 (0xF0): Reserved</b>				
7	Reserved		RO	1
6	Pass All Frames	Port-based enable to pass all frames 1 = Enable 0 = Disable <b>Note:</b> This is used in the port mirroring with RX sniff only.	R/W	0
5–4	Reserved	Reserved	RO	0000
3	Insert Source Port PVID for Untagged Packet Destination to Highest Egress Port	Register 176: Insert source Port 1 PVID for untagged frame at egress Port 5 Register 192: Insert source Port 2 PVID for untagged frame at egress Port 5 Register 208: Insert source Port 3 PVID for untagged frame at egress Port 5 Register 224: Insert source Port 4 PVID for untagged frame at egress Port 5 Register 240: Insert source Port 5 PVID for untagged frame at egress Port 4 <b>Note:</b> Enabled by the Register 135 bit [2].	R/W	0
2	Insert Source Port PVID for Untagged Packet Destination to Second Highest Egress Port	Register 176: Insert source Port 1 PVID for untagged frame at egress Port 4 Register 192: Insert source Port 2 PVID for untagged frame at egress Port 4 Register 208: Insert source Port 3 PVID for untagged frame at egress Port 4 Register 224: Insert source Port 4 PVID for untagged frame at egress Port 3 Register 240: Insert source Port 5 PVID for untagged frame at egress Port 3 <b>Note:</b> Enabled by the Register 135 bit [2].	R/W	0

**Advanced Control Registers (Continued)**

Address	Name	Description	Mode	Default
1	Insert Source Port PVID for Untagged Packet Destination to Second Lowest Egress Port	<p>Register 176: Insert source Port 1 PVID for untagged frame at egress Port 3</p> <p>Register 192: Insert source Port 2 PVID for untagged frame at egress Port 3</p> <p>Register 208: Insert source Port 3 PVID for untagged frame at egress Port 2</p> <p>Register 224: Insert source Port 4 PVID for untagged frame at egress Port 2</p> <p>Register 240: Insert source Port 5 PVID for untagged frame at egress Port 2</p> <p><b>Note:</b> Enabled by the Register 135 bit [2].</p>	R/W	0
0	Insert Source Port PVID for Untagged Packet Destination to Lowest Egress Port	<p>Register 176: Insert source Port 1 PVID for untagged frame at egress Port 2</p> <p>Register 192: Insert source Port 2 PVID for untagged frame at egress Port 1</p> <p>Register 208: Insert source Port 3 PVID for untagged frame at egress Port 1</p> <p>Register 224: Insert source Port 4 PVID for untagged frame at egress Port 1</p> <p>Register 240: Insert source Port 5 PVID for untagged frame at egress Port 1</p> <p><b>Note:</b> Enabled by the Register 135 bit [2].</p>	R/W	0
<p><b>Register 177 (0xB1): Port 1 Control 13</b></p> <p><b>Register 193 (0xC1): Port 2 Control 13</b></p> <p><b>Register 209 (0xD1): Port 3 Control 13</b></p> <p><b>Register 225 (0xE1): Port 4 Control 13</b></p> <p><b>Register 241 (0xF1): Port 5 Control 13</b></p>				
7-2	Reserved		RO	0000000
1	4 Queue Split Enable	<p>This bit, in combination with Register16/32/48/64/80 bit [0], selects the split of 1, 2, and 4 queues: {Register 177 bit [1], Register 16 bit [0] = }:</p> <p>11 = Reserved.</p> <p>10 = The port output queue is split into four priority queues or if mapping 802.1p to priority 0-3 mode.</p> <p>01 = The port output queue is split into two priority queues or if mapping 802.1p to priority 0-3 mode.</p> <p>00 = Single output queue on the port. There is no priority differentiation even though packets are classified into high and low priority.</p>	R/W	0
0	Enable Dropping Tag	<p>0 = Disable tagged packets drop</p> <p>1 = Enable tagged packets drop</p>	R/W	0

**Advanced Control Registers (Continued)**

Address	Name	Description	Mode	Default
<b>Register 178 (0xB2): Port 1 Control 14</b>				
<b>Register 194 (0xC2): Port 2 Control 14</b>				
<b>Register 210 (0xD2): Port 3 Control 14</b>				
<b>Register 226 (0xE2): Port 4 Control 14</b>				
<b>Register 242 (0xF2): Port 5 Control 14</b>				
7	Enable Port Transmit Queue 3 Ratio	0 = Strict priority transmits all the packets from this Priority Queue 3 before transmitting lower-priority queues. 1 = Bits [6:0] reflect the packet number allowing it to transmit from this Priority Queue 3 within a certain time.	R/W	1
6-0	Port Transmit Queue 3 Ratio[6:0]	Packet number for Transmit Queue 3 for highest priority packets in four-queues mode.	R/W	0001000
<b>Register 179 (0xB3): Port 1 Control 15</b>				
<b>Register 195 (0xC3): Port 2 Control 15</b>				
<b>Register 211 (0xD3): Port 3 Control 15</b>				
<b>Register 227 (0xE3): Port 4 Control 15</b>				
<b>Register 243 (0xF3): Port 5 Control 15</b>				
7	Enable Port Transmit Queue 2 Ratio	0 = Strict priority transmits all the packets from this Priority Queue 2 before transmitting lower-priority queues. 1 = Bits [6:0] reflect the packet number allowing it to transmit from this Priority Queue 2 within a certain time.	R/W	1
6-0	Port Transmit Queue 2 Ratio[6:0]	Packet number for Transmit Queue 2 for high/low priority packets in high/low priority packets in four-queues mode.	R/W	0000100
<b>Register 180 (0xB4): Port 1 Control 16</b>				
<b>Register 196 (0xC4): Port 2 Control 16</b>				
<b>Register 212 (0xD4): Port 3 Control 16</b>				
<b>Register 228 (0xE4): Port 4 Control 16</b>				
<b>Register 244 (0xF4): Port 5 Control 16</b>				
7	Enable Port Transmit Queue 1 Ratio	0 = Strict priority transmits all the packets from this Priority Queue 1 before transmitting lower-priority queues. 1 = Bits [6:0] reflect the packet number allowing it to transmit from this Priority Queue 1 within a certain time.	R/W	1
6-0	Port Transmit Queue 1 Ratio[6:0]	Packet number for Transmit Queue 1 for low/high priority packets in four-queues mode and high priority packets in two-queues mode.	R/W	0000010



**Advanced Control Registers (Continued)**

Address	Name	Description	Mode	Default
<b>Register 181 (0xB5): Port 1 Control 17</b> <b>Register 197 (0xC5): Port 2 Control 17</b> <b>Register 213 (0xD5): Port 3 Control 17</b> <b>Register 229 (0xE5): Port 4 Control 17</b> <b>Register 245 (0xF5): Port 5 Control 17</b>				
7	Enable Port Transmit Queue 0 Ratio	0 = Strict priority transmits all the packets from this Priority Queue 0 before transmitting lower-priority queues. 1 = Bits [6:0] reflect the packet number allowing it to transmit from this Priority Queue 0 within a certain time.	R/W	1
6-0	Port Transmit Queue 0 Ratio[6:0]	Packet number for Transmit Queue 0 for lowest priority packets in four-queues mode and low priority packets in two-queue mode.	R/W	000001
<b>Register 182 (0xB6): Port 1 Rate Limit Control</b> <b>Register 198 (0xC6): Port 2 Rate Limit Control</b> <b>Register 214 (0xD6): Port 3 Rate Limit Control</b> <b>Register 230 (0xE6): Port 4 Rate Limit Control</b> <b>Register 246 (0xF6): Port 5 Rate Limit Control</b>				
7	Reserved		RO	0
6	Ingress Limit Port/Priority-Based Select	1 = Ingress rate limit is port-based 0 = Ingress rate limit is priority-based	R/W	0
5	Ingress Limit Bit/Packets Mode Select	1 = Rate limit is counted based on the number of packets. 0 = Rate limit is counted based on the number of bits.	R/W	0
4	Ingress Rate Limit Flow Control Enable	1 = Flow control is asserted if the port's receive rate is exceeded. 0 = Flow control is not asserted if the port's receive rate is exceeded.	R/W	0
3-2	Ingress Limit Mode	These bits determine what type of frames are limited and counted against ingress rate limiting. 00 = Limit and count all frames. 01 = Limit and count broadcast, multicast, and flooded unicast frames. 10 = Limit and count broadcast and multicast frames only. 11 = Limit and count broadcast frames only.	R/W	00
1	Count IFG Bytes	1 = Each frame's minimum inter-frame gap (IFG) bytes (12 per frame) are included in ingress and egress rate limiting calculations. 0 = IFG bytes are not counted.	R/W	0
0	Count Preamble Bytes	1 = Each frame's preamble bytes (8 per frame) are included in ingress and egress rate limiting calculations. 0 = Preamble bytes are not counted.	R/W	0

## Advanced Control Registers (Continued)

Address	Name	Description	Mode	Default
<b>Register 183 (0xB7): Port 1 Priority 0 Ingress Limit Control 1<sup>(7)</sup></b>				
<b>Register 199 (0xC7): Port 2 Priority 0 Ingress Limit Control 1</b>				
<b>Register 215 (0xD7): Port 3 Priority 0 Ingress Limit Control 1</b>				
<b>Register 231 (0xE7): Port 4 Priority 0 Ingress Limit Control 1</b>				
<b>Register 247 (0xF7): Port 5 Priority 0 Ingress Limit Control 1</b>				
7	Reserved		RO	0
6-0	Port-Based Priority 0 Ingress Limit	Ingress data rate limit for priority 0 frames. Ingress traffic from this port is shaped according to the Rate Selection Table in the Rate Limit Support section.	R/W	0000000
<b>Register 184 (0xB8): Port 1 Priority 1 Ingress Limit Control 2<sup>(7)</sup></b>				
<b>Register 200 (0xC8): Port 2 Priority 1 Ingress Limit Control 2</b>				
<b>Register 216 (0xD8): Port 3 Priority 1 Ingress Limit Control 2</b>				
<b>Register 232 (0xE8): Port 4 Priority 1 Ingress Limit Control 2</b>				
<b>Register 248 (0xF8): Port 5 Priority 1 Ingress Limit Control 2</b>				
7	Reserved		RO	0
6-0	Port-Based Priority 1 Ingress Limit	Ingress data rate limit for priority 1 frames. Ingress traffic from this port is shaped according to the Rate Selection Table in the Rate Limit Support section.	R/W	0000000
<b>Register 185 (0xB9): Port 1 Priority 2 Ingress Limit Control 3<sup>(7)</sup></b>				
<b>Register 201 (0xC9): Port 2 Priority 2 Ingress Limit Control 3</b>				
<b>Register 217 (0xD9): Port 3 Priority 2 Ingress Limit Control 3</b>				
<b>Register 233 (0xE9): Port 4 Priority 2 Ingress Limit Control 3</b>				
<b>Register 249 (0xF9): Port 5 Priority 2 Ingress Limit Control 3</b>				
7	Reserved		RO	0
6-0	Port-Based Priority 2 Ingress Limit	Ingress data rate limit for priority 2 frames. Ingress traffic from this port is shaped according to the Rate Selection Table in the Rate Limit Support section.	R/W	0000000
<b>Register 186 (0xBA): Port 1 Priority 3 Ingress Limit Control 4<sup>(7)</sup></b>				
<b>Register 202 (0xCA): Port 2 Priority 3 Ingress Limit Control 4</b>				
<b>Register 218 (0xDA): Port 3 Priority 3 Ingress Limit Control 4</b>				
<b>Register 234 (0xEA): Port 4 Priority 3 Ingress Limit Control 4</b>				
<b>Register 250 (0xFA): Port 5 Priority 3 Ingress Limit Control 4</b>				
7	Port-Based Ingress Rate Limit Enable	Any write to this register triggers port ingress rate limit engine to take effect for all the priority queues according to priority ingress limit control. <b>Note:</b> For the port priority 0-3 ingress rate limit control to take effect, bit [7] in Register 186, 202, 218, 234, and 250 for Ports 1, 2, 3, 4, and 5, respectively will need to be set after configured bits [6:0] of Port Ingress Limit Control 1-4 registers.	R/W	0
6-0	Port-Based Priority 3 Ingress Limit	Ingress data rate limit for priority 3 frames. Ingress traffic from this port is shaped according to the Rate Selection Table in the Rate Limit Support section.	R/W	0000000

**Note:**

7. In the port priority 0-3 ingress rate limit mode, all related egress ports should be set to two-queues or four-queues mode.

**Advanced Control Registers (Continued)**

Address	Name	Description	Mode	Default
<b>Register 187 (0xBB): Port 1 Queue 0 Egress Limit Control 1<sup>(8)</sup></b>				
<b>Register 203 (0xCB): Port 2 Queue 0 Egress Limit Control 1</b>				
<b>Register 219 (0xDB): Port 3 Queue 0 Egress Limit Control 1</b>				
<b>Register 235 (0xEB): Port 4 Queue 0 Egress Limit Control 1</b>				
<b>Register 251 (0xFB): Port 5 Queue 0 Egress Limit Control 1</b>				
7	Reserved		RO	0
6-0	Port Queue 0 Egress Limit	Egress data rate limit for priority 0 frames. Egress traffic from this priority queue is shaped according to the Rate Selection Table in the Rate Limit Support section.  In four-queues mode, it is lowest priority.  In two-queues mode, it is low priority.	R/W	0000000
<b>Register 188 (0xBC): Port 1 Queue 1 Egress Limit Control 2<sup>(8)</sup></b>				
<b>Register 204 (0xCC): Port 2 Queue 1 Egress Limit Control 2</b>				
<b>Register 220 (0xDC): Port 3 Queue 1 Egress Limit Control 2</b>				
<b>Register 236 (0xEC): Port 4 Queue 1 Egress Limit Control 2</b>				
<b>Register 252 (0xFC): Port 5 Queue 1 Egress Limit Control 2</b>				
7	Reserved		RO	0
6-0	Port Queue 1 Egress Limit	Egress data rate limit for priority 1 frames. Egress traffic from this priority queue is shaped according to the Rate Selection Table in the Rate Limit Support section.  In four-queues mode, it is low/high priority.  In two-queues mode, it is high priority.	R/W	0000000
<b>Register 189 (0xBD): Port 1 Queue 2 Egress Limit Control 3<sup>(8)</sup></b>				
<b>Register 205 (0xCD): Port 2 Queue 2 Egress Limit Control 3</b>				
<b>Register 221 (0xDD): Port 3 Queue 2 Egress Limit Control 3</b>				
<b>Register 237 (0xED): Port 4 Queue 2 Egress Limit Control 3</b>				
<b>Register 253 (0xFD): Port 5 Queue 2 Egress Limit Control 3</b>				
7	Reserved		RO	0
6-0	Port Queue 2 Egress Limit	Egress data rate limit for priority 2 frames. Egress traffic from this priority queue is shaped according to the Rate Selection Table in the Rate Limit Support section.  In four queues mode, it is high/low priority.	R/W	0000000

**Note:**

8. In the port queue 0-3 egress rate limit mode, the highest priority gets the exact rate limit based on the rate select table. Other packets' priority rates are based upon the ratio of the Port Control 14/15/16/17 Registers when using more than one egress queue per port.

Address	Name	Description	Mode	Default
<b>Register 190 (0xBE): Port 1 Queue 3 Egress Limit Control 4<sup>(8)</sup></b>				
<b>Register 206 (0xCE): Port 2 Queue 3 Egress Limit Control 4</b>				
<b>Register 222 (0xDE): Port 3 Queue 3 Egress Limit Control 4</b>				
<b>Register 238 (0xEE): Port 4 Queue 3 Egress Limit Control 4</b>				
<b>Register 254 (0xFE): Port 5 Queue 3 Egress Limit Control 4</b>				
7	Reserved		RO	0
6-0	Port Queue 3 Egress Limit	Egress data rate limit for priority 3 frames. Egress traffic from this priority queue is shaped according to the Rate Selection Table in the Rate Limit Support section.  In four-queues mode, it is highest priority.	R/W	0000000
<b>Register 191 (0xBF): Testing Register</b>				
7-0	Reserved	N/A Don't change	RO	0x80
<b>Register 207 (0xCF): Reserved Control Register</b>				
7-0	Reserved	N/A Don't change	RO	0x15
<b>Register 223 (0xDF): Test Register 2</b>				
7-0	Reserved	N/A Don't change	RO	0x0C
<b>Register 239 (0xEF): Test Register 3</b>				
7-0	Reserved	N/A Don't change	RO	0x32
<b>Register 255 (0xFF): Testing Register 4</b>				
7-0	Reserved	N/A Don't change	RO	0x00

## Indirect Register Description

Control	Indirect Address	Contents
Direct Address 0x6E Function Select bits [7-5] = 000 Table_select bits [3-2] = 00	0x000 – 0x01F	Static MAC address table entry 0 – 31
Direct Address 0x6E Function Select bits [7-5] = 000 Table_select bits [3-2] = 01	0x000 – 0x1FF	VLAN table bucket 0 – 1023 (4 entries per bucket)
Direct Address 0x6E Function Select bits [7-5] = 000 Table_select bits [3-2] = 10	0x000 – 0x1FF	Dynamic MAC address table entry 0 – 1023
Direct Address 0x6E Function Select bits [7-5] = 000 Table_select bits [3-2] = 11	0x000 – 0x08F, 0x100 – 0x109	0x000 – 0x01F Port 1 MIB counters 0x020 – 0x03F Port 2 MIB counters 0x040 – 0x05F Port 3 MIB counters 0x060 – 0x07F Port 4 MIB counters 0x080 – 0x09F Port 5 MIB counters 0x100 – 0x113 Total bytes and dropped MIB counters
Direct Address 0x6E Function Select bits [7-5] = 001, bits [3-0] = Indirect Address, bits [11-8] = MSB Indirect Address = port indirect register address 0xn	{0xn, 6h00} – {0xn, 6h05}	Port-based 16-bit EEE Control Registers 0 – 5 n = port number Use Indirect Byte Register (0xA0)
Direct Address 0x6E Function Select bits [7-5] = 010, bits [3-0] = Indirect Address, bits [11-8] = MSB Indirect Address = port indirect register address 0xn	{0xn, 6h00} – {0xn, 6h1F}	ACL entry 0 – 15, 6h00 and 6h01 for entry 0, etc. n = port number Use Indirect Byte Register(0xA0)
Direct Address 0x6E Function Select bits [7-5] = 011, bits [3-0] = Indirect Address, bits [11-8] = MSB Indirect Address = port indirect register address 0xn	{0xn, 8h00} – {0xn, 8h4FF}	Reserved for the factory
Direct Address 0x6E Function Select bits [7-5] = 100, bits [3-0] = Indirect Address, bits [11-8] = MSB Indirect Address = port indirect register address 0xn	{0xn, 8h00} – {0xn, 8h4FF}	Configuration Registers, PME, etc. n = 0 - Global n = 1 – 4 Port number Use Indirect Byte Register(0xA0)
Direct Address 0x6E Function Select bits [7-5] = 101, bits [3-0] = Indirect Address, bits [11-8] = MSB Indirect Address = port indirect register address 0xn	{0xn, 8h00} – {0xn, 8h4FF}	Reserved for the factory

## Static MAC Address Table

The KSZ8775CLX incorporates a static and a dynamic address table. When a DA look-up is requested, both tables are searched to make a packet forwarding decision. When an SA look-up is requested, only the dynamic table is searched for aging, migration, and learning purposes. The static DA look-up result has preference over the dynamic DA look-up result. If there are DA matches in both tables, the result from the static table is used. The static table can only be accessed and controlled by an external SPI master (usually a processor). The entries in the static table are not aged out by KSZ8775CLX. An external device does all addition, modification, and deletion.

Register bit assignments are different for static MAC table reads and static MAC table writes, as shown in the two tables below.

**Table 19. Format of Static MAC Addresses for Reads (32 Entries)**

Address	Name	Description	Mode	Default
63-57	FID	Filter VLAN ID, representing one of the 128 active VLANs.	RO	0000000
56	Use FID	1 = Use (FID+MAC) to look-up in static table. 0 = Use MAC only to look-up in static table.	RO	0
55	Reserved	Reserved.	RO	N/A
54	Override	1 = Override spanning tree "transmit enable = 0" or "receive enable = 0" setting. This bit is used for spanning tree implementation. 0 = No override.	RO	0
53	Valid	1 = This entry is valid, the look-up result will be used. 0 = This entry is not valid.	RO	0
52-48	Forwarding Ports	These 5 bits control the forward ports. For example: 00001 = Forward to Port 1 00010 = Forward to Port 2 00100 = Forward to Port 3 01000 = Forward to Port 4 10000 = Forward to Port 5 00110 = Forward to Port 2 and Port 3 11111 = Broadcasting (excluding the ingress port)	RO	00000
47-0	MAC Address (DA)	48-bit MAC address.	RO	0x0

## Static MAC Address Table (Continued)

Table 20. Format of Static MAC Addresses for Writes (32 Entries)

Address	Name	Description	Mode	Default
62-56	FID	Filter VLAN ID, representing one of the 128 active VLANs.	W	0000000
55	Use FID	1 = Use (FID+MAC) to look-up in static table. 0 = Use MAC only to look-up in static table.	W	0
54	Override	1 = Override spanning tree "transmit enable = 0" or "receive enable = 0" setting. This bit is used for spanning tree implementation. 0 = No override.	W	0
53	Valid	1 = This entry is valid, the look-up result will be used. 0 = This entry is not valid.	W	0
52-48	Forwarding Ports	These 5 bits control the forward ports. For example: 00001 = Forward to Port 1 00010 = Forward to Port 2 00100 = Forward to Port 3 01000 = Forward to Port 4 10000 = Forward to Port 5 00110 = Forward to Port 2 and Port 3 11111 = Broadcasting (excluding the ingress port)	W	00000
47-0	MAC Address (DA)	48-bit MAC address.	W	0x0

### Examples:

- Static Address Table Read (read the 2nd entry)  
Write to Register 110 with 0x10 (read static table selected)  
Write to Register 111 with 0x1 (trigger the read operation)  
Then  
Read Register 113 (63:56)  
Read Register 114 (55:48)  
Read Register 115 (47:40)  
Read Register 116 (39:32)  
Read Register 117 (31:24)  
Read Register 118 (23:16)  
Read Register 119 (15:8)  
Read Register 120 (7:0)
- Static Address Table Write (write the 8th entry)  
Write Register 113 (62:56)  
Write Register 114 (55:48)  
Write Register 115 (47:40)  
Write Register 116 (39:32)  
Write Register 117 (31:24)  
Write Register 118 (23:16)  
Write Register 119 (15:8)

Write Register 120 (7:0)

Write to Register 110 with 0x00 (write static table selected)

Write to Register 111 with 0x7 (trigger the write operation)

## VLAN Table

The VLAN table is used for look-up. If 802.1q VLAN mode is enabled (Register 5 bit [7] = 1), this table is used to retrieve VLAN information that is associated with the ingress packet. There are three fields for filter ID (FID), Valid, and VLAN membership in the VLAN table. The three fields must be initialized before the table is used. There is no VID field because 4096 VIDs are used as a dedicated memory address index into a 1024x52-bit memory space. Each entry has four VLANs. Each VLAN has 13 bits. Four VLANs need 52 bits. There are a total of 1024 entries to support a total of 4096 VLAN IDs by using dedicated memory address and data bits. Refer to the table below for details. FID has 7 bits to support 128 active VLANs.

**Table 21. VLAN Table**

Address	Name	Description	Mode	Initial Value Suggestion
<b>Format of Static VLAN Table (Support Max 4096 VLAN ID entries and 128 Active VLANs)</b>				
12	Valid	1 = The entry is valid. 0 = Entry is invalid.	R/W	0
11-7	Membership	Specifies which ports are members of the VLAN. If a DA look-up fails (no match in both static and dynamic tables), the packet associated with this VLAN will be forwarded to the ports specified in this field. For example, 11001 means Ports 5, 4, and 1 are in this VLAN.	R/W	11111
6-0	FID	Filter ID. The KSZ8775CLX supports 128 active VLANs represented by these seven-bit fields. FID is the mapped ID. If 802.1q VLAN is enabled, the look-up will be based on FID+DA and FID+SA.	R/W	0

If 802.1q VLAN mode is enabled, the KSZ8775CLX assigns a VID to every ingress packet when the packet is untagged or tagged with a null VID, the packet is assigned with the default port VID of the ingress port. If the packet is tagged with non-null VID, the VID in the tag is used. The look-up process starts from the VLAN table look-up based on a VID number with its dedicated memory address and data bits. If the entry is not valid in the VLAN table, the packet is dropped and no address learning occurs. If the entry is valid, the FID is retrieved. The FID+DA and FID+SA lookups in MAC tables are performed. The FID+DA look-up determines the forwarding ports. If FID+DA fails for look-up in the MAC table, the packet is broadcast to all the members or specified members (excluding the ingress port) based on the VLAN table. If FID+SA fails, the FID+SA is learned. To communicate between different active VLANs, set the same FID; otherwise, set a different FID.

The VLAN table configuration is organized as 1024 VLAN sets. Each VLAN set consists of four VLAN entries to support up to 4096 VLAN entries. Each VLAN set has 60 bits total and 3 reversed bits are inserted between entries. 52 bits are used for the VLAN set, which should be read or written at the same time specified by the indirect address.

The VLAN entries in the VLAN set are mapped to indirect data registers as follows:

- Entry0[12:0] maps to the VLAN set bits [12:0] {Register 119[4:0], Register 120[7:0]}
- Entry1[12:0] maps to the VLAN set bits[28:16] {Register 117[4:0], Register 118[7:0]}
- Entry2[12:0] maps to the VLAN set bits[44:32] {Register 115[4:0], Register 116[7:0]}
- Entry3[12:0] maps to the VLAN set bits[60:48] {Register 113[4:0], Register 114[7:0]}



In order to read one VLAN entry, the VLAN set is read first and the specific VLAN entry information is extracted. To update any VLAN entry, the VLAN set is read first, then only the desired VLAN entry is updated and the whole VLAN set is written back. The FID in the VLAN table is 7 bits, so the VLAN table supports unique 128 flow VLAN groups. Each VLAN set address is 10 bits long (maximum is 1024) in the Indirect Address Register 110 and 111, the bits [9:8] of VLAN set address is at bits [1:0] of Register 110, and the bits [7:0] of VLAN set address is at bits [7:0] of Register 111. Each write and read can access up to four consecutive VLAN entries.

Examples:

- VLAN Table Read (read the VID = 2 entry)  
Write the indirect control and address registers first  
Write to Register 110 (0x6E) with 0x14 (read VLAN table selected)  
Write to Register 111 (0x6F) with 0x0 (trigger the read operation for VID = 0, 1, 2, 3 entries)  
Then read the Indirect Data Registers bits [38:26] for VID = 2 entry  
Read Register 115 (0x73), (Register 115 [4:0] are bits [12:8] of VLAN VID = 2 entry)  
Read Register 116 (0x74), (Register 116 [7:0] are bits [7:0] of VLAN VID = 2 entry)
- VLAN Table Write (write the VID = 10 entry)  
Read the VLAN set that contains VID = 8, 9, 10, 11.  
Write to Register 110 (0x6E) with 0x14 (read VLAN table selected)  
Write to Register 111 (0x6F) with 0x02 (trigger the read operation and VID = 8, 9, 10, 11 indirect address)  
Read the VLAN set first by the Indirect Data Registers 113, 114, 115, 116, 117, 118, 119, 120.  
Modify the Indirect Data Registers bits [44:32] by the Register 115 bit[4:0] and Register 116 bits [7:0] as follows  
Write to Register 115 (0x73), (Register 115 [4:0] are bits [12:8] of VLAN VID = 10 entry)  
Write to Register 116 (0x74), (Register 116 [7:0] are bits [7:0] of VLAN VID = 10 entry)  
Then write the indirect control and address Registers  
Write to Register 110 (0x6E) with 0x04 (write VLAN table selected)  
Write to Register 111 (0x6F) with 0x02 (trigger the write operation and VID = 8, 9, 10, 11 indirect address)

The following table shows the relationship between the indirect address/data registers and the VLAN ID.

**Table 22. Indirect Registers and VLAN ID**

Indirect Address High/Low bit[9-0] for VLAN Sets	Indirect Data Registers bits for Each VLAN Entry	VID Numbers	VID bit[12-2] in VLAN Tag	VID bit[1-0] in VLAN Tag
0	Bits [12:0]	0	0	0
0	Bits [28:16]	1	0	1
0	Bits [44:32]	2	0	2
0	Bits [60:48]	3	0	3
1	Bits [12:0]	4	1	0
1	Bits [28:16]	5	1	1
1	Bits [44:32]	6	1	2
1	Bits [60:48]	7	1	3
2	Bits [12:0]	8	2	0
2	Bits [28:16]	9	2	1
2	Bits [44:32]	10	2	2
2	Bits [60:48]	11	2	3
:	:	:	:	:
:	:	:	:	:
:	:	:	:	:
1023	Bits [12:0]	4092	1023	0
1023	Bits [28:16]	4093	1023	1
1023	Bits [44:32]	4094	1023	2
1023	Bits [60:48]	4095	1023	3

## Dynamic MAC Address Table

The following table is read-only.

**Table 23. Dynamic MAC Address Table**

Address	Name	Description	Mode	Default
<b>Format of Dynamic MAC Address Table (1K entries)</b>				
71	MAC Empty	1 = There are no valid entries in the table. 0 = There are valid entries in the table.	RO	1
70-61	Number of Valid Entries	Indicates how many valid entries in the table. 0x3ff means 1K entries 0x1 and bit [71] = 0: means 2 entries 0x0 and bit [71] = 0: means 1 entry 0x0 and bit [71] = 1: means 0 entry	RO	0
60-59	Time Stamp	2-bit counters for internal aging	RO	
58-56	Source Port	The source port where FID+MAC is learned. 000 = Port 1 001 = Port 2 010 = Port 3 011 = Port 4 100 = Port 5	RO	0x0
55	Data Ready	1 = The entry is not ready, retry until this bit is set to 0. 0 = The entry is ready.	RO	
54-48	FID	Filter ID.	RO	0x0
47-0	MAC Address	48-bit MAC address.	RO	0x0

### Examples:

- Dynamic MAC Address Table Read (read the 1st entry), and retrieve the MAC table size  
Write to Register 110 with 0x18 (read dynamic table selected)  
Write to Register 111 with 0x0 (trigger the read operation) and then  
Read Register 112 (71:64)  
Read Register 113 (63:56); // the above two registers show # of entries  
Read Register 114 (55:48) // if bit [55] is 1, restart (reread) from this register  
Read Register 115 (47:40)  
Read Register 116 (39:32)  
Read Register 117 (31:24)  
Read Register 118 (23:16)  
Read Register 119 (15:8)  
Read Register 120 (7:0)
- Dynamic MAC Address Table Read (read the 257th entry), without retrieving # of entries information  
Write to Register 110 with 0x19 (read dynamic table selected)  
Write to Register 111 with 0x1 (trigger the read operation) and then

Read Register 112 (71:64)

Read Register 113 (63:56)

Read Register 114 (55:48) // if bit [55] is 1, restart (reread) from this register

Read Register 115 (47:40)

Read Register 116 (39:32)

Read Register 117 (31:24)

Read Register 118 (23:16)

Read Register 119 (15:8)

Read Register 120 (7:0)

## PME Indirect Registers

The EEE registers are provided on global and per port basis. These registers are read/write using indirect memory access as shown below.

**Table 24. PME Indirect Registers**

Address	Name	Description	Mode	Default
Global PME Control Register				
Register 110 (0x6E) bits [7:5] = 100 for PME, Register 110 bits [3:0] = 0x0 for the indirect global register, Register 111 (0x6F) bits [7:0] = Offset to access the Indirect Byte Register 0xA0. Offset: 0x00 (bits [31:24]), 0x01 (bits [23:16]), 0x02 (bit [15:8]), 0x03 (bits [7:0]). Location: (100 PME) → {0x0, offset} → 0xA0 holds the data.				
31-2	Reserved		RO	All '0'
1	PME Output Enable	1= PME output pin is enabled. 0= PME output pin is disabled.	R/W	0
0	PME Output Polarity	1= PME output pin is active high. 0= PME output pin is active low.	R/W	0
Port PME Control Status Register				
Register 110 (0x6E) bits [7:5] = 100 for PME, Register 110 bits [3:0] = 0xn for the Indirect Port Register (n = 1,2,3,4). Register 111 (0x6F) bits [7:0] = Offset to access the Indirect Byte Register 0xA0. Offset: 0x00 (bits [31:24]), 0x01 (bits [23:16]), 0x02 (bits [5:8]), 0x03 (bits [7:0]). Location: (100 PME) → {0xn, offset} → 0xA0 holds the data.				
31-3	Reserved		RO	All '0'
2	Magic Packet Detect	1 = Magic packet is detected at any port (write 1 to clear). 0 = No magic packet is detected.	R/W W1C	0
1	Link Up Detect	1 = Link up is detected at any port (write 1 to clear). 0 = No link-up is detected.	R/W W1C	0
0	Energy Detect	1 = Energy is detected at any port (write 1 to clear). 0 = No energy is detected.	R/W W1C	0
Port PME Control Mask Register				
Register 110 (0x6E) bits [7:5] = 100 for PME, Register 110 bits [3:0] = 0xn for port (n = 1,2,3,4). Register 111 (0x6F) bits [7:0] = Offset to access the Indirect Byte Register 0xA0. Offset: 0x04 (bits [31:24]), 0x05 (bits [23:16]), 0x06 (bits [15:8]), 0x07 (bits [7:0]). Location: (100 PME) → {0xn, offset} → 0xA0 holds the data.				
31-3	Reserved		RO	All '0'
2	Magic Packet Detect Enable	1 = The PME pin will be asserted when a magic packet is detected at host QMU. 0 = The PME pin will not be asserted by the magic packet detection.	R/W	0
1	Link Up Detect Enable	1 = The PME pin will be asserted when a link-up is detected at any port. 0 = The PME pin will not be asserted by the link-up detection.	R/W	0
0	Energy Detect Enable	1 = The PME pin will be asserted when energy on line is detected at any port. 0 = The PME pin will not be asserted by the energy detection.	R/W	0

## Programming Examples

### ***Read Operation***

1. Use the Indirect Access Control Register to select register to be read, to read Global PME Control Register. Write 0x90 to the Register 110 (0x6E) // PME selected and read operation, and 4 MSBs of Port number (Register 110 bits [3:0]) = 0 for the Global PME Register.
2. Write 0x03 to the Register 111 (0x6F) // trigger the read operation for bits [7:0] of the Global PME Control Register.
3. Read the Indirect Byte Register 160 (0xA0) // Get the value of the Global PME Control Register.

### ***Write Operation***

1. Write 0x80 to the Register 110 (0x6E) //PME selected and write operation, and 4 MSBs of Port number = 0 for the Global PME Register.
2. Write 0x03 to the Register 111 (0x6F) // select write the bits [7:0] of the Global PME Control Address Register.
3. Write new value to the Indirect Byte Register 160 bits [7:0] (0xA0) //Write value to the Global PME Control Register of the Indirect PME Data Register by the assigned the indirect data register address.

## ACL Rule Table and ACL Indirect Registers

### ACL Register and Programming Model

The ACL registers are accessible by the microcontroller through a serial interface. The per-port register set is accessed through the indirect addressing mechanism. The ACL entries are stored in the format shown in the following figure. Each ACL rule list table can input up to 16 entries per port. The total of five ACL rule list tables can be set for five ports.

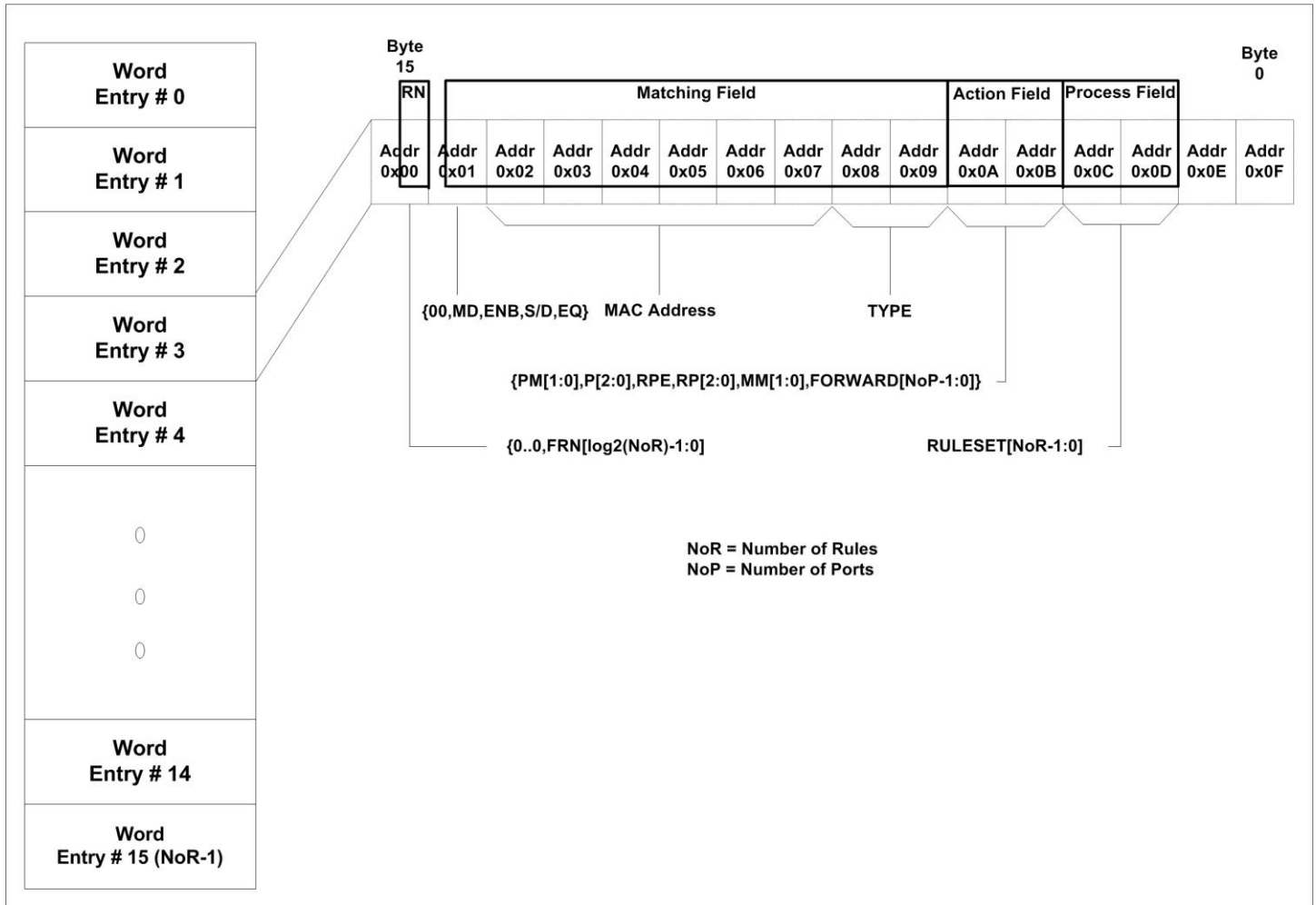

Figure 15. ACL Table Access

To update any port-based ACL registers, it is suggested to execute a read modify write sequence for each 128-bit entry (112 are used) addressed by the indirect address register to ensure the integrity of control content. A minimum of two indirect control writes and two indirect control reads are needed for each ACL entry read access (indirect data read shall follow), and a minimum of one indirect control read and three indirect control writes are required for each ACL entry write access. Each 112-bit port-based ACL word entry (ACL Word) is accomplished through a sequence of the Indirect Access Control 0 Registers 110 (0x6E) access by specifying the bits[3:0] 4-bit port number (indirect address [11:8]) and 8-bit indirect register address (indirect address[7:0]) in the Indirect Access Control 1 Register 111 (0x6F). The address numbers 0x00-0x0d are used to specify the byte location of each entry (see Figure 15). Address 0x00 indicates the byte 15 (MSB) of each 128-bit entry, address 0x01 indicates the byte 14, etc. Bytes at address 0x0E and 0x0F are reserved for the future. Address 0x10 and 0x11 hold bit-wise byte enable for each entry. Address 0x12 is used as control and status register. The format of these registers is defined in the following section.

**ACL Indirect Registers**

The information in this table is used to implement ACL mode selection and per-port filtering.

**Table 25. Temporary Storage for 14-Bytes ACL Rules**

Address	Name	Description	Mode	Default
<b>Port_ACL_0</b>				
ACL Port Register 0 (0x00) Register 110 (0x6E) bits [7:5] = 010 for ACL, Register 110 bits [3:0] = 0xn for Port 1, 2, 3, 4, and 5. Register 111 (0x6F) bits [7:0] = Offset 0x00 to access the Indirect Byte Register 0xA0. Location: (010 ACL) → {0xn, offset} → 0xA0 holds the data. Processing Field				
7-4	Reserved		RO	0x0
3-0	FRN[3:0]	This is for the first rule number of the rule set. There are a total of 16 entries per port in the ACL rule table. Each single rule can be set with another rule for a rule set by the ACL Port Register 12 (0x0c) and Register 13 (0x0d).  Whether using a single rule or rule set, users have to assign an entry for using which Action Field via FRN[3:0].	R/W	0000
<b>Port_ACL_1</b>				
ACL Port Register 1 (0x01) Register 110 (0x6E) bits [7:5] = 010 for ACL, Register 110 bits [3:0] = 0xn for Port 1, 2, 3, 4, and 5. Register 111 (0x6F) bits [7:0] = Offset 0x01 to access the Indirect Byte Register 0xA0. Location: (010 ACL) → {0xn, offset} → 0xA0 holds the data. Matching Fields				
7-6	Reserved		RO	00
5-4	MD[1:0]	MODE 00 = Disable the current rule list, no action taken 01 = Qualify rules for Layer 2 MAC header filtering 10 = Used for Layer 3 IP address filtering 11 = Performs Layer 4 TCP port number/protocol filtering	R/W	00



Address	Name	Description	Mode	Default
3-2	ENB[1:0]	<p>ENABLE</p> <p>When MD=01:</p> <p>00 = The 11 bits from PM, P, REP, MM in action field specify a count value for packets matching MAC Address and TYPE in Matching Field.</p> <p>The count unit is defined in FORWARD field bit [4];                      Bit [4] = 0, <math>\mu</math>s is used.                      Bit [4] = 1, ms is used.</p> <p>The FORWARDED field bit [3] determines the algorithm used to generate interrupt when counter terminated. Bit [3] = 0, an 11-bit counter will be loaded with the count value from the list and start counting down every unit time. An interrupt will be generated when expires (i.e., next qualified packet has not been received within the period specified by the value).</p> <p>Bit [3] = 1, the counter is incremented every matched packet received and the interrupt is generated while terminal count reached, the count resets thereafter.</p> <p>01 = MAC address bit field is participating in test.                      10 = MAC TYPE bit field is used for test.                      11 = Both MAC address and TYPE are tested against these bit fields in the list.</p> <p>When MD=10:</p> <p>00 = Reserved.                      01 = IP address and mask or IP protocol is enabled to be tested accordingly.                      10 = SA and DA are compared; the drop/forward decision is based on the E/Q bit setting.                      11 = Reserved</p> <p>When MD=11:</p> <p>00 = Protocol comparison is enabled.                      01 = TCP/UDP address comparison is selected.                      10 = It is same with '01'                      11 = The sequence number of TCP is compared.</p>	R/W	00
1	S_D	<p>Source/Destination Address</p> <p>0 = DA is used to compare.                      1 = SA is used to compare</p>	R/W	0
0	EQ	<p>Compare Equal</p> <p>0 = Match if they are not equal.                      1 = Match if they are equal.</p>	R/W	0
<p><b>Port_ACL_2</b>                      ACL Port Register 2 (0x02)                      Register 110 (0x6E) bits [7:5] = 010 for ACL, Register 110 bits[3:0] = 0xn for Port 1, 2, 3, 4, and 5.                      Register 111 (0x6F) bits [7:0] = Offset 0x02 to access the Indirect Byte Register 0xA0.                      Location: (010 ACL) → {0xn, offset} → 0xA0 holds the data.</p> <p>Matching Fields for Layer 2</p>				
7-0	MAC_ADDR[47:40]	MAC Address	R/W	00000000

Address	Name	Description	Mode	Default
<b>Port_ACL_3</b> ACL Port Register 3 (0x03) Register 110 (0x6E) bits [7:5] = 010 for ACL, Register 110 bits [3:0] = 0xn for Port 1, 2, 3, 4, and 5. Register 111 (0x6F) bits [7:0] = Offset 0x03 to access the Indirect Byte Register 0xA0. Location: (010 ACL) → {0xn, offset} → 0xA0 holds the data. Matching Fields for Layer 2				
7-0	MAC_ADDR[39:32]	MAC Address	R/W	00000000
<b>Port_ACL_4</b> ACL Port Register 4 (0x04) Register 110 (0x6E) bits [7:5] = 010 for ACL, Register 110 bits [3:0] = 0xn for Port 1, 2, 3, 4, and 5. Register 111 (0x6F) bits [7:0] = Offset 0x04 to access the Indirect Byte Register 0xA0. Location: (010 ACL) → {0xn, offset} → 0xA0 holds the data. Matching Fields for Layer 2				
7-0	MAC_ADDR[31:24]	MAC Address	R/W	00000000
<b>Port_ACL_5</b> ACL Port Register 5 (0x05) Register 110 (0x6E) bits [7:5] = 010 for ACL, Register 110 bits [3:0] = 0xn for Port 1, 2, 3, 4, and 5. Register 111 (0x6F) bits [7:0] = Offset 0x05 to access the Indirect Byte Register 0xA0. Location: (010 ACL) → {0xn, offset} → 0xA0 holds the data. Matching Fields for Layer 2				
7-0	MAC_ADDR[23:16]	MAC Address	R/W	00000000
<b>Port_ACL_6</b> ACL Port Register 6 (0x06) Register 110 (0x6E) bits [7:5] = 010 for ACL, Register 110 bits [3:0] = 0xn for Port 1, 2, 3, 4, and 5. Register 111 (0x6F) bits [7:0] = Offset 0x06 to access the Indirect Byte Register 0xA0. Location: (010 ACL) → {0xn, offset} → 0xA0 holds the data. Matching Fields for Layer 2				
7-0	MAC_ADDR[15:8]	MAC Address	R/W	00000000
<b>Port_ACL_7</b> ACL Port Register 7 (0x07) Register 110 (0x6E) bits [7:5] = 010 for ACL, Register 110 bits [3:0] = 0xn for Port 1, 2, 3, 4, and 5. Register 111 (0x6F) bits [7:0] = Offset 0x07 to access the Indirect Byte Register 0xA0. Location: (010 ACL) → {0xn, offset} → 0xA0 holds the data. Matching Fields for Layer 2				
7-0	MAC_ADDR[7:0]	MAC Address	R/W	00000000
<b>Port_ACL_8</b> ACL Port Register 8 (0x08) Register 110 (0x6E) bits [7:5] = 010 for ACL, Register 110 bits [3:0] = 0xn for Port 1, 2, 3, 4, and 5. Register 111 (0x6F) bits [7:0] = Offset 0x08 to access the Indirect Byte Register 0xA0. Location: (010 ACL) → {0xn, offset} → 0xA0 holds the data. Matching Fields for Layer 2				
7-0	TYPE[15:8]	Ether Type	R/W	00000000
<b>Port_ACL_9</b> ACL Port Register 9 (0x09) Register 110 (0x6E) bits [7:5] = 010 for ACL, Register 110 bits [3:0] = 0xn for Port 1, 2, 3, 4, and 5. Register 111 (0x6F) bits [7:0] = Offset 0x09 to access the Indirect Byte Register 0xA0. Location: (010 ACL) → {0xn, offset} → 0xA0 holds the data. Matching Fields for Layer 2				
7-0	TYPE[7:0]	Ether Type	R/W	00000000

Address	Name	Description	Mode	Default
<b>Note: Layer 2, Layer 3, and Layer 4 in matching field should be in different entries. Same layer should be in same entry. See ACL Format figure for details.</b>				
<b>Port_ACL_2</b> ACL Port Register 2 (0x02) Register 110 (0x6E) bits [7:5] = 010 for ACL, Register 110 bits[3:0] = 0xn for Port 1, 2, 3, 4, and 5. Register 111 (0x6F) bits [7:0] = Offset 0x02 to access the Indirect Byte Register 0xA0. Location: (010 ACL) → {0xn, offset} → 0xA0 holds the data. Matching Fields for Layer 3				
7-0	IP_ADDR[31:24]	IP Address	R/W	00000000
<b>Port_ACL_3</b> ACL Port Register 3 (0x03) Register 110 (0x6E) bits [7:5] = 010 for ACL, Register 110 bits [3:0] = 0xn for Port 1, 2, 3, 4, and 5. Register 111 (0x6F) bits [7:0] = Offset 0x03 to access the Indirect Byte Register 0xA0. Location: (010 ACL) → {0xn, offset} → 0xA0 holds the data. Matching Fields for Layer 3				
7-0	IP_ADDR[23:16]	IP Address	R/W	00000000
<b>Port_ACL_4</b> ACL Port Register 4 (0x04) Register 110 (0x6E) bits [7:5] = 010 for ACL, Register 110 bits [3:0] = 0xn for Port 1, 2, 3, 4, and 5. Register 111 (0x6F) bits [7:0] = Offset 0x04 to access the Indirect Byte Register 0xA0. Location: (010 ACL) → {0xn, offset} → 0xA0 holds the data. Matching Fields for Layer 3 IP				
7-0	IP_ADDR[15:8]	IP Address	R/W	00000000
<b>Port_ACL_5</b> ACL Port Register 5 (0x05) Register 110 (0x6E) bits [7:5] = 010 for ACL, Register 110 bits [3:0] = 0xn for Port 1, 2, 3, 4, and 5. Register 111 (0x6F) bits [7:0] = Offset 0x05 to access the Indirect Byte Register 0xA0. Location: (010 ACL) → {0xn, offset} → 0xA0 holds the data. Matching Fields for Layer 3				
7-0	IP_ADDR[7:0]	IP Address	R/W	00000000
<b>Port_ACL_6</b> ACL Port Register 6 (0x06) Register 110 (0x6E) bits [7:5] = 010 for ACL, Register 110 bits [3:0] = 0xn for Port 1, 2, 3, 4, and 5. Register 111 (0x6F) bits [7:0] = Offset 0x06 to access the Indirect Byte Register 0xA0. Location: (010 ACL) → {0xn, offset} → 0xA0 holds the data. Matching Fields for Layer 3				
7-0	IP_Mask[31:24]	IP Mask	R/W	00000000
<b>Port_ACL_7</b> ACL Port Register 7 (0x07) Register 110 (0x6E) bits [7:5] = 010 for ACL, Register 110 bits [3:0] = 0xn for Port 1, 2, 3, 4, and 5. Register 111 (0x6F) bits [7:0] = Offset 0x07 to access the Indirect Byte Register 0xA0. Location: (010 ACL) → {0xn, offset} → 0xA0 holds the data. Matching Fields for Layer 3				
7-0	IP_Mask[23:16]	IP Mask	R/W	00000000

Address	Name	Description	Mode	Default
<b>Port_ACL_8</b> ACL Port Register 8 (0x08) Register 110 (0x6E) bits [7:5] = 010 for ACL, Register 110 bits [3:0] = 0xn for Port 1, 2, 3, 4, and 5. Register 111 (0x6F) bits [7:0] = Offset 0x08 to access the Indirect Byte Register 0xA0. Location: (010 ACL) → {0xn, offset} → 0xA0 holds the data. Matching Fields for Layer 3				
7-0	IP_Mask[15:8]	IP Mask	R/W	00000000
<b>Port_ACL_9</b> ACL Port Register 9 (0x09) Register 110 (0x6E) bits [7:5] = 010 for ACL, Register 110 bits [3:0] = 0xn for Port 1, 2, 3, 4, and 5. Register 111 (0x6F) bits [7:0] = Offset 0x09 to access the Indirect Byte Register 0xA0. Location: (010 ACL) → {0xn, offset} → 0xA0 holds the data. Matching Fields for Layer 3				
7-0	IP_Mask[7:0]	IP Mask	R/W	00000000
<b>Note: Layer 2, Layer 3, and Layer 4 in matching field should be in different entries. Same layer should be in same entry. See ACL Format figure for details.</b>				
<b>Port_ACL_2</b> ACL Port Register 2 (0x02) Register 110 (0x6E) bits [7:5] = 010 for ACL, Register 110 bits [3:0] = 0xn for Port 1, 2, 3, 4, and 5. Register 111 (0x6F) bits [7:0] = Offset 0x02 to access the Indirect Byte Register 0xA0. Location: (010 ACL) → {0xn, offset} → 0xA0 holds the data. Matching Fields for Layer 4				
7-0	MAX Port[15:8]	For range of TCP port number or sequence number matching	R/W	00000000
<b>Port_ACL_3</b> ACL Port Register 3 (0x03) Register 110 (0x6E) bits [7:5] = 010 for ACL, Register 110 bits [3:0] = 0xn for Port 1, 2, 3, 4, and 5. Register 111 (0x6F) bits [7:0] = Offset 0x03 to access the Indirect Byte Register 0xA0. Location: (010 ACL) → {0xn, offset} → 0xA0 holds the data. Matching Fields for Layer 4				
7-0	MIN Port[7:0]	For range of TCP port number or sequence number matching	R/W	00000000
<b>Port_ACL_4</b> ACL Port Register 4 (0x04) Register 110 (0x6E) bits [7:5] = 010 for ACL, Register 110 bits [3:0] = 0xn for Port 1, 2, 3, 4, and 5. Register 111 (0x6F) bits [7:0] = Offset 0x04 to access the Indirect Byte Register 0xA0. Location: (010 ACL) → {0xn, offset} → 0xA0 holds the data. Matching Fields for Layer 4				
7-3	Reserved	Reserved	RO	00000
2-1	PC [1:0]	00 = The port comparison is disabled. 01 = Matching either one of MAX or MIN. 10 = Match if the port number is in the range of MAX and MIN. 11 = Match if the port number is out of the range	R/W	00
0	PRO[7]	For the IP protocol to be matched		0

Address	Name	Description	Mode	Default
<b>Port_ACL_5</b> ACL Port Register 5 (0x05) Register 110 (0x6E) bits [7:5] = 010 for ACL, Register 110 bits [3:0] = 0xn for Port 1, 2, 3, 4, and 5. Register 111 (0x6F) bits [7:0] = Offset 0x05 to access the Indirect Byte Register 0xA0. Location: (010 ACL) → {0xn, offset} → 0xA0 holds the data. Matching Fields for Layer 4				
7-1	PRO[6:0]	For the IP protocol to be matched	R/W	0000000
0	FME	Flag Match Enable 0 = Disable TCP FLAG matching 1 = Enable TCP FLAG matching	R/W	0
<b>Port_ACL_6</b> ACL Port Register 6 (0x06) Register 110 (0x6E) bits [7:5] = 010 for ACL, Register 110 bits [3:0] = 0xn for Port 1, 2, 3, 4, and 5. Register 111 (0x6F) bits [7:0] = Offset 0x06 to access the Indirect Byte Register 0xA0. Location: (010 ACL) → {0xn, offset} → 0xA0 holds the data. Matching Fields for Layer 4				
7-0	FMSK[7:0]	TCP FLAG Mask	R/W	00000000
<b>Port_ACL_7</b> ACL Port Register 7 (0x07) Register 110 (0x6E) bits [7:5] = 010 for ACL, Register 110 bits [3:0] = 0xn for Port 1, 2, 3, 4, and 5. Register 111 (0x6F) bits [7:0] = Offset 0x07 to access the Indirect Byte Register 0xA0. Location: (010 ACL) → {0xn, offset} → 0xA0 holds the data. Matching Fields for Layer 4				
7-0	FLAG[7:0]	TCP FLAG	R/W	00000000
<b>Port_ACL_8</b> ACL Port Register 8 (0x08) Register 110 (0x6E) bits [7:5] = 010 for ACL, Register 110 bits [3:0] = 0xn for Port 1, 2, 3, 4, and 5. Register 111 (0x6F) bits [7:0] = Offset 0x08 to access the Indirect Byte Register 0xA0. Location: (010 ACL) → {0xn, offset} → 0xA0 holds the data.				
7-0	Reserved	Reserved	RO	00000000
<b>Port_ACL_9</b> ACL Port Register 9 (0x09) Register 110 (0x6E) bits [7:5] = 010 for ACL, Register 110 bits [3:0] = 0xn for Port 1, 2, 3, 4, and 5. Register 111 (0x6F) bits [7:0] = Offset 0x09 to access the Indirect Byte Register 0xA0. Location: (010 ACL) → {0xn, offset} → 0xA0 holds the data.				
7-0	Reserved	Reserved	RO	00000000
<b>Note: Layer 2, Layer 3, and Layer 4 in matching field should be in different entries. Same layer should be in same entry. See ACL Format figure for details.</b>				

Address	Name	Description	Mode	Default
<b>Port_ACL_A</b> ACL Port Register 10 (0x0A) Register 110 (0x6E) bits [7:5] = 010 for ACL, Register 110 bits [3:0] = 0xn for Port 1, 2, 3, 4, and 5. Register 111 (0x6F) bits [7:0] = Offset 0x0A to access the Indirect Byte Register 0xA0. Location: (010 ACL) → {0xn, offset} → 0xA0 holds the data. Action Field				
7-6	PM[1:0]	Priority Mode  00 = No priority is selected; the priority determined by QoS. Classification is used in the tagged packets.  01 = Priority in P [2:0] bits field is used if it is greater than QoS result in the 3-bit priority field of the tagged packets received.  10 = Priority in P [2:0] bits field is used if it is smaller than QoS result in the 3-bit priority field of the tagged packets received.  11 = P [2:0] bits field will replace the 3-bit priority field of the tagged packets received.	R/W	00
5-3	P[2:0]	Priority <b>Note:</b> The 3-bit priority value to be used depends on PM [1:0] setting in bits [7:6].	R/W	000
2	RPE	Remark Priority Enable  0 = No remarking is necessary.  1 = VLAN priority bits in the packets are replaced by RP [2:1] bits field below in the list.	R/W	0
1-0	RP[2:1]	Remark Priority  00 = Priority 0 01 = Priority 1 10 = Priority 2 11 = Priority 3	R/W	00
<b>Port_ACL_B</b> ACL Port Register 11 (0x0B) Register 110 (0x6E) bits [7:5] = 010 for ACL, Register 110 bits [3:0] = 0xn for Port 1, 2, 3, 4, and 5. Register 111 (0x6F) bits [7:0] = Offset 0x0B to access the Indirect Byte Register 0xA0. Location: (010 ACL) → {0xn, offset} → 0xA0 holds the data. Action Field				
7	RP[0]	Remark Priority	R/W	0
6-5	MM[1:0]	Map Mode  00 = No forwarding remapping is necessary. Don't use the forwarding map in FORWARD field, use the forwarding map from the look-up table only.  01 = The forwarding map in FORWARD field is OR'ed with the forwarding map from the look-up table.  10 = The forwarding map in FORWARD field is AND'ed with the forwarding map from the look-up table.  11 = The forwarding map in FORWARD field replaces the forwarding map from the look-up table.	R/W	00

Address	Name	Description	Mode	Default
4-0	FORWARD[4:0]	<p>Port Map</p> <p>Each bit indicates forwarding decision of one port.</p> <p>Bit [0] = Port 1                      Bit [1] = Port 2                      Bit [2] = Port 3                      Bit [3] = Port 4                      Bit [4] = Port 5</p> <p>When MD=01 and ENB=00,</p> <p>Bit [4] is used as count unit:                      0 = <math>\mu</math>s                      1 = ms</p> <p>Bit [3] is used to select count modes:</p> <p>0 = Count down in the 11-bit counter from an assigned value in the action field PM, P, RPE, RP and MM, an interrupt will be generated when expired.</p> <p>1 = Count up in the 11-bit counter for every matched packet received up to reach an assigned value in the action field PM, P, RPE, RP and MM, and then an interrupt will be generated.</p> <p><b>Note:</b> See ENB field description for detail.</p>	R/W	
<p><b>Port_ACL_C</b>                      ACL Port Register 12 (0x0C)                      Register 110 (0x6E) bits [7:5] = 010 for ACL, Register 110 bits [3:0] = 0xn for Port 1, 2, 3, 4, and 5.                      Register 111 (0x6F) bits [7:0] = Offset 0x0C to access the Indirect Byte Register 0xA0.                      Location: (010 ACL) <math>\rightarrow</math> {0xn, offset} <math>\rightarrow</math> 0xA0 holds the data.                      Processing Field</p>				
7-0	RULESET[15:8]	Each bit indicates this entry in bits 0 to 16, total 16 entries of the rule list can be assigned for the rule set to be used in the rules cascade per port.	R/W	00000000
<p><b>Port_ACL_D</b>                      ACL Port Register 13 (0x0D)                      Register 110 (0x6E) bits [7:5] = 010 for ACL, Register 110 bits [3:0] = 0xn for Port 1, 2, 3, 4, and 5.                      Register 111 (0x6F) bits [7:0] = Offset 0x0D to access the Indirect Byte Register 0xA0.                      Location: (010 ACL) <math>\rightarrow</math> {0xn, offset} <math>\rightarrow</math> 0xA0 holds the data.                      Processing Field</p>				
7-0	RULESET[7:0]	Each bit indicates this entry in bits [0-15] 16 entries of the rule list to be assigned for the rule set to be used in the rules cascade per port.	R/W	00000000

**Table 26. Temporary Storage for 14-byte ACL Rules**

Address	Name	Description	Mode	Default
<b>Port_ACL_BYTE_ENB_MSB</b>				
ACL Port Register 14 (0x10)				
Register 110 (0x6E) bits [7:5] = 010 for ACL, Register 110 bits [3:0] = 0xn for Port 1, 2, 3, and 4.				
Register 111 (0x6F) bits [7:0] = Offset 0x10 to access the Indirect Byte Register 0xA0.				
Location: (010 ACL) → {0xn, offset} → 0xA0 holds the data.				
7-6	Reserved		RO	00
5-0	BYTE_ENB[13:8]	Byte Enable in ACL table; 14 bytes per entry 1 = Byte is selected for read/write 0 = Byte is not selected Bit [0] of BYTE_ENB[13:0] is for byte address 0x0D in ACL table entry Bit [1] of BYTE_ENB[13:0] is for byte address 0x0C in ACL table entry Bit [13] of BYTE_ENB[13:0] is for byte address 0x00 in ACL table entry	R/W	0
<b>Port_ACL_BYTE_ENB_LSB</b>				
ACL Port Register 15 (0x11)				
Register 110 (0x6E) bits [7:5] = 010 for ACL, Register 110 bits [3:0] = 0xn for Port 1, 2, 3, 4, and 5.				
Register 111 (0x6F) bits [7:0] = Offset 0x11 to access the Indirect Byte Register 0xA0.				
Location: (010 ACL) → {0xn, offset} → 0xA0 holds the data.				
7-0	BYTE_ENB[7:0]	Byte Enable in ACL table; 14 bytes per entry 1 = Byte is selected for read/write 0 = Byte is not selected Bit [0] of BYTE_ENB[13:0] is for byte address 0x0D in ACL table entry Bit [1] of BYTE_ENB[13:0] is for byte address 0x0C in ACL table entry Bit [13] of BYTE_ENB[13:0] is for byte address 0x00 in ACL table entry.	R/W	0x00



Table 27. ACL Read and Write Control

Address	Name	Description	Mode	Default
<b>Port_ACL_ACCESS_CONTROL1</b> ACL Port Register 16 (0x12) Register 110 (0x6E) bits [7:5] = 010 for ACL, Register 110 bits [3:0] = 0xn for Port 1, 2, 3, 4, and 5. Register 111 (0x6F) bits [7:0] = Offset 0x12 to access the Indirect Byte Register 0xA0. Location: (010 ACL) → {0xn, offset} → 0xA0 holds the data.				
7	Reserved	N/A Don't change	RO	0
6	WRITE_STATUS	Write Operation Status 1 = Write completed 0 = Write is in progress	RO	1
5	READ_STATUS	Read Operation Status 1 = Read completed 0 = Read is in progress	RO	1
4	WRITE_READ	Request Type 1 = Write 0 = Read	R/W	0
3-0	ACL_ENTRY_ADDRESS	ACL Entry Address 0000= entry 0. 0001= entry 1 1111= entry 15.	R/W	0000
<b>Port_ACL_ACCESS_CONTROL2</b> ACL Port Register 17 (0x13) Register 110 (0x6E) bits [7:5] = 010 for ACL, Register 110 bits [3:0] = 0xn for Port 1, 2, 3, 4, and 5. Register 111 (0x6F) bits [7:0] = Offset 0x13 to access the Indirect Byte Register 0xA0. Location: (010 ACL) → {0xn, offset} → 0xA0 holds the data.				
7-1	Reserved	N/A Don't change	RO	0000000
0	Force Device Level Redundancy (DLR) Miss	1 = DLR filtering uses single ACL entry. DLR packet matching the ACL entry will be considered as MISS 0 = DLR filtering uses multiple ACL entries. DLR packet matching the rule set for DLR packet will be considered as HIT.	R/W	0

The ACL registers can be programmed using the read/write examples below.

#### Examples:

##### Read Operation

- Use the Indirect Access Control Register to select register to be read. To read Entry0 that is 1st entry of Port 1:  
Write 0x41 to Register 110 (0x6E) // select ACL and write to Port 1 (Port 2, 3, 4 and 5 are 0x42, 0x43, 0x44 and 0x45)  
Write 0x10 to Register 111 (0x6F) // trigger the write operation for Port 1 in the ACL Port Register 14 (Byte Enable MSB register) address.  
Write 0x3F into the Indirect Byte Register 160 (0xA0) for MSB of Byte Enable word.  
Write 0x41 to Register 110 (0x6E) // select write to Port 1.  
Write 0x11 to Register 111 (0x6F) // trigger the write operation for Port 1 in the ACL Port Register 15 (Byte Enable LSB Register) address. (The above 2 may be part of burst).  
Write 0xFF into the Indirect Byte Register 160 (0xA0) for LSB of Byte Enable word.

(The above steps set Byte Enable Register to select all bytes in ACL word from 0x00-0x0d in ACL table entry)

Write 0x41 to Register 110 (0x6E) //select ACL and write operations to Port 1.

Write 0x12 to Register 111 (0x6F) //Write ACL read/write control register address 0x12 to the indirect address in Register 111 to trigger the read operation for Port 1 in the ACL Port Register 16 (ACL Access Control Register) to read entry 0.

Write 0x00 into the Indirect Byte Register 160 (0xA0)//ACL Port Register 16 (0x12) bit[4]=0 to read ACL and bits [3:0] = 0x0 for entry 0.

(The above steps set ACL control register to read ACL entry word 0).

Write 0x51 to Register 110 (0x6E) //select ACL and read to Port 1 (Port 2, 3, 4 and 5 are 0x52, 0x53, 0x54 and 0x55).

Write 0x12 to Register 111 (0x6F) //trigger the read operation for Port 1 in the ACL Port Register16 (ACL Access Control 1).

Read the Indirect Byte Register 160 (0xA0) to get data (If bit [5] is set, the read completes in the ACL port Register 16 (0x12) and go to next step. Otherwise, repeat the above polling step).

Write 0x51 to Register 110 (0x6E) // select read to Port 1.

Write 0x00 to Register 111 (0x6F) // trigger the read/burst read operation(s) based on the Byte Enable Register setting by the Port 1 ACL access Register 0 (0x00).

Read/Burst read the Indirect Byte Register 160 (0xA0) // to get data of ACL entry word 0, write 0x00 to 0x0D indirect address and read Register 160 (0xA0) after each byte address write to Register 111 (0x6F).

### **Write Operation**

- Use the Indirect Access Control Register to select register to be written. To write even byte number of 15th entry of Port 5:

Write 0x55 to Register 110 (0x6E) // select ACL and read to Port 5.

Write 0x12 to Register 111 (0x6F) // trigger the read operation for Port 5 ACL Access Control Register read.

Read the Indirect Byte Register 160 (0xA0) to get data (If bit [6] is set, the previous write completes and go to next step. Otherwise, repeat the above polling step).

Write 0x45 to Register 110 (0x6E) // select ACL and write to Port 5.

Write 0x00 to Register 111 (0x6F) //set offset address for Port 5 ACL Port Register 0.

Write/Burst write the Indirect Byte Register 160 (0xA0) for ACL Port Register 0, 1, 2, ...,13 from 0x00 to 0x0D) (Write or Burst write even bytes of Port 5 ACL access Registers 0, 1, ..., 13 to holding buffer).

Write 0x45 to Register 110 (0x6E) // select ACL and write to Port 5.

Write 0x10 to Register 111 (0x6F) // trigger the write operation for Port 5 in the ACL Port Register 14 (Byte Enable MSB register).

Write 0x15 into the Indirect Byte Register 160 (0xA0) for MSB of Byte Enable word to enable odd bytes address 0x01, 0x03 and 0x05.

Write 0x45 to Register 110 (0x6E) // select write to Port 5.

Write 0x11 to Register 111 (0x6F) // trigger the write operation for Port 5 in the ACL Port Register 15 (Byte Enable LSB register).

Write 0x55 into the Indirect Byte Register 160 (0xA0) for LSB of Byte Enable word to enable odd bytes address 0x07, 0x09, 0x0B and 0x0D.

(The above steps set Byte Enable register to select odd address bytes in ACL word)

Write 0x45 to Register 110 (0x6E) // select write to Port 5.

Write 0x12 to Register 111 (0x6F) // write the port ACL access control register address (0x12) to the Indirect Address Register 111 for setting the write operation to Port 5 in the ACL Port Register 16 to write entry 15 bytes 1, 3, 5...,13.

Write 0x1F into the Indirect Byte Register 160 (0xA0) // for the write operation to 15th entry in the ACL Port Register 16 (0x12) bit4=1 to write ACL, bits [3:0] = 0xF to write entry 15.

(The above steps set ACL Control Register to write ACL entry word 15 from holding buffer)

The bit arrangement of above example assumes Layer 2 rule of MODE = 01 in ACL Port Register 1 (0x01), refer to ACL format for MODE = 10 and 11.

## EEE Indirect Registers

The EEE function is for all copper ports only. The EEE registers are provided on global and per port basis. These registers are read/write using indirect memory access as shown below.

**Table 28. EEE Global Registers**

Address	Name	Description	Mode	Default
<b>EEE Global Register 0</b>				
Global EEE QM Buffer Control Register Register 110 (0x6E) bits [7:5] = 001 for EEE, Register 110 bits [3:0] = 0x0 for the indirect global register, Register 111 (0x6F) bits [7:0] = Offset to access the Indirect Byte Register 0xA0. Offset: 0x30 (bits [15:8]), 0x31 (bits [7:0]) Location: (001 EEE) → {0x0, offset} → 0xA0 holds the data.				
15-8	Reserved	N/A Don't change	RO	0x40
7	Low Power Idle (LPI) Terminated By Input Traffic Enable	1 = LPI request will be stopped if input traffic is detected. 0 = LPI request won't be stopped by input traffic.	R/W	0
6-0	Reserved	N/A Don't change	RO	0x10
<b>EEE Global Register 1</b>				
Global Empty TXQ to LPI Wait Time Control Register Register 110 (0x6E) bits [7:5] = 001 for EEE, Register 110 bits [3:0] = 0x0 for the indirect global register, Register 111 (0x6F) bits [7:0] = Offset to access the Indirect Byte Register 0xA0. Offset: 0x32 (bits [15:8]), 0x33 (bits [7:0]) Location: (001 EEE) → {0x0, offset} → 0xA0 holds the data.				
15-0	Empty TXQ to LPI Wait Time	This register specifies the time that the LPI request will be generated after a TXQ has been empty exceeds this configured time. This is only valid when EEE 100BT is enabled. This setting will apply to all the ports. The unit is 1.3ms. The default value is 1.3 sec. (range from 1.3ms to 86 second)	R/W	0x10
<b>EEE Global Register 2</b>				
Global EEE PCS DIAGNOSTIC Register Register 110 (0x6E) bits [7:5] = 001 for EEE, Register 110 bits [3:0] = 0x0 for the indirect global register, Register 111 (0x6F) bits [7:0] = Offset to access the Indirect Byte Register 0xA0. Offset: 0x34(bits [15:8]), 0x35 (bits [7:0]) Location: (001 EEE) → {0x0, offset} → 0xA0 holds the data.				
15-12	Reserved	N/A Don't change	RO	0x6
11-8	Reserved	N/A Don't change	RO	0x8
7-4	Reserved	N/A Don't change	RO	0x0
3	Port 4 Next Page Enable	1 = Enable next page exchange during auto-negotiation. 0 = Skip next page exchange during auto-negotiation.	R/W	1
2	Port 3 Next Page Enable	1 = Enable next page exchange during auto-negotiation. 0 = Skip next page exchange during auto-negotiation.	R/W	1
1	Port 2 Next Page Enable	1 = Enable next page exchange during auto-negotiation. 0 = Skip next page exchange during auto-negotiation.	R/W	1
0	Port 1 Next Page Enable	1 = Enable next page exchange during auto-negotiation. 0 = Skip next page exchange during auto-negotiation.	R/W	1

Address	Name	Description	Mode	Default
<b>EEE Global Register 3</b> Global EEE Minimum LPI cycles before back to Idle Control Register Register 110 (0x6E) bits [7:5] = 001 for EEE, Register 110 bits [3:0] = 0x0 for the indirect global register, Register 111 (0x6F) bits [7:0] = Offset to access the Indirect Byte Register 0xA0. Offset: 0x36 (bits [15:8], 0x37 (bits [7:0]) Location: (001 EEE) → {0x0, offset} → 0xA0 holds the data.				
15-0	Reserved	N/A Don't change	RO	0x0000
<b>EEE Global Register 4</b> Global EEE Wakeup Error Threshold Control Register Register 110 (0x6E) bits [7:5] = 001 for EEE, Register 110 bits [3:0] = 0x0 for the indirect global register, Register 111 (0x6F) bits [7:0] = Offset to access the Indirect Byte Register 0xA0. Offset: 0x38 (bits [15:8]), 0x39 (bits [7:0]) Location: (001 EEE) → {0x0, offset} → 0xA0 holds the data.				
15-0	EEE Wakeup Threshold	This value specifies the maximum time allowed for PHY to wake up. If wakeup time is longer than this, EEE wakeup error count will be incremented. <b>Note:</b> This is an EEE standard, don't change.	RO	0x0201
<b>EEE Global Register 5</b> Global EEE PCS Diagnostic Control Register Register 110 (0x6E) bits [7:5] = 001 for EEE, Register 110 bits [3:0] = 0x0 for the indirect global register, Register 111 (0x6F) bits [7:0] = Offset to access the Indirect Byte Register 0xA0. Offset: 0x3A (bits [15:8]), 0x3B (bits [7:0]) Location: (001 EEE) → {0x0, offset} → 0xA0 holds the data.				
15-0	Reserved	N/A Don't change	RO	0x0001

Table 29. EEE Port Registers

Address	Name	Description	Mode	Default
<b>EEE Port Register 0</b> Port Auto-Negotiation Expansion Status Register Register 110 (0x6E) bits [7:5] = 001 for EEE, Register 110 bits [3:0] = 0xn, n = 3-4 for the Indirect Port Register , Register 111 (0x6F) bits [7:0] = Offset to access the Indirect Byte Register 0xA0. Offset: 0x0C (bits [15:8]), 0x0D (bits [7:0]) Location: (001 EEE) → {0xn, offset} → 0xA0 holds the data.				
15-7	Reserved	N/A Don't change	RO	9h000
6	Receive Next Page Location Able	1 = Received Next Page storage location is specified by bits [6:5] 0 = Received Next Page storage location is not specified by bits [6:5]	RO	1
5	Received Next Page Storage Location	1 = Link Partner Next Pages are stored in MIIM Register 8h (Additional next page) 0 = Link Partner Next Pages are stored in MIIM Register 5h	RO	1
4	Parallel Detection Fault	1 = A fault has been detected via the Parallel Detection function. 0 = A fault has not been detected via the Parallel Detection function. This bit is cleared after reading.	R/LH	0

Address	Name	Description	Mode	Default
3	Link Partner Next Page Able	1 = Link Partner is Next Page abled 0 = Link Partner is not Next Page abled	RO	0
2	Next Page Able	1 = Local Device is Next Page abled 0 = Local Device is not Next Page abled	RO	1
1	Page Received	1 = A New Page has been received 0 = A New Page has not been received	R/LH	0
0	Link Partner Auto-Negotiation Able	1 = Link Partner is Auto-Negotiation abled 0 = Link Partner is not Auto-Negotiation abled	RO	0
<b>EEE Port Register 1</b> Port Auto-Negotiation Next Page Transmit Register Register 110 (0x6E) bits [7:5] = 001 for EEE, Register 110 bits [3:0] = 0xn, n = 3-4 for the Indirect Port Register , Register 111 (0x6F) bits [7:0] = Offset to access the Indirect Byte Register 0xA0. Offset: 0x0E (bits [15:8]), 0x0F (bits [7:0]) Location: (001 EEE) → {0xn, offset} → 0xA0 holds the data. This register doesn't need to be set if EEE Port Register 5 bit[7] = 1 default for automatically perform EEE capability				
15	Next Page	Next Page (NP) is used by the Next Page function to indicate whether or not this is the last Next Page to be transmitted. NP shall be set as follows: 1 = Additional Next Page(s) will follow. 0 = Last page.	R/W	0
14	Reserved	Reserved	RO	0
13	Message Page	Message Page (MP) is used by the Next Page function to differentiate a Message Page from an Unformatted Page. MP shall be set as follows: 1 = Message Page 0 = Unformatted Page	R/W	1
12	Acknowledge 2	Acknowledge 2 (Ack2) is used by the Next Page function to indicate that a device has the ability to comply with the message. Ack2 shall be set as follows: 1 = Will comply with message. 0 = Cannot comply with message.	R/W	0
11	Toggle	Toggle (T) is used by the Arbitration function to ensure synchronization with the Link Partner during Next Page exchange. This bit shall always take the opposite value of the Toggle bit in the previously exchanged Link Codeword. The initial value of the Toggle bit in the first Next Page transmitted is the inverse of bit [11] in the base Link Codeword and, therefore, may assume a value of logic one or zero. The Toggle bit shall be set as follows: 1 = Previous value of the transmitted Link Codeword equal to logic zero. 0 = Previous value of the transmitted Link Codeword equal to logic one.	RO	0
10-0	Message/Unformatted Code Field	Message/Unformatted Code field bits [10:0]	R/W	1

Address	Name	Description	Mode	Default
<b>EEE Port Register 2</b>				
Port Auto-Negotiation Link Partner Next Page Receive Register Register 110 (0x6E) bits [7:5] = 001 for EEE, Register 110 bits [3:0] = 0xn, n = 3-4 for the indirect port register, Register 111 (0x6F) bits [7:0] = Offset to access the Indirect Byte Register 0xA0. Offset: 0x10 (bits [15:8]), 0x11 (bits [7:0]) Location: (001 EEE) → {0xn, offset} → 0xA0 holds the data.				
15	Next Page	Next Page (NP) is used by the Next Page function to indicate whether or not this is the last Next Page to be transmitted. NP shall be set as follows: 1 = Additional Next Page(s) will follow. 0 = Last page.	RO	0
14	Acknowledge	Acknowledge (Ack) is used by the Auto-Negotiation function to indicate that a device has successfully received its Link Partner's Link Codeword. The Acknowledge Bit is encoded in bit D14 regardless of the value of the Selector Field or Link Codeword encoding. If no Next Page information is to be sent, this bit shall be set to logic one in the Link Codeword after the reception of at least three consecutive and consistent FLP Bursts (ignoring the Acknowledge bit value).	RO	0
13	Message Page	Message Page (MP) is used by the Next Page function to differentiate a Message Page from an Unformatted Page. MP shall be set as follows: 1 = Message Page 0 = Unformatted Page	RO	0
12	Acknowledge 2	Acknowledge 2 (Ack2) is used by the Next Page function to indicate that a device has the ability to comply with the message. Ack2 shall be set as follows: 1 = Will comply with message. 0 = Cannot comply with message.	RO	0
11	Toggle	Toggle (T) is used by the Arbitration function to ensure synchronization with the Link Partner during Next Page exchange. This bit shall always take the opposite value of the Toggle bit in the previously exchanged Link Codeword. The initial value of the Toggle bit in the first Next Page transmitted is the inverse of bit [11] in the base Link Codeword and, therefore, may assume a value of logic one or zero. The Toggle bit shall be set as follows: 1 = Previous value of the transmitted Link Codeword equal to logic zero. 0 = Previous value of the transmitted Link Codeword equal to logic one.	RO	0
10-0	Message/Unformatted Code Field	Message/Unformatted Code field bits [10:0]	RO	0
<b>EEE Port Register 3</b>				
Link Partner EEE Capability Status and Local Device EEE Capability Advisement Register Register 110 (0x6E) bits [7:5] = 001 for EEE, Register 110 bits [3:0] = 0xn, n = 3-4 for the Indirect Port Register, Register 111 (0x6F) bits [7:0] = Offset to access the Indirect Byte Register 0xA0. Offset: 0x28 (bits [15:8]), 0x29 (bits [7:0]) Location: (001 EEE) → {0xn, offset} → 0xA0 holds the data.				
15	Reserved	N/A Don't change	RO	0
14	Link Partner (LP) 10GBASE-KR EEE	1 = EEE is supported for 10GBASE-KR 0 = EEE is not supported for 10GBASE-KR	RO	0

Address	Name	Description	Mode	Default
13	LP 10GBASE-KX4 EEE	1 = EEE is supported for 10GBASE-KX4 0 = EEE is not supported for 10GBASE-KX4	RO	0
12	LP 1000BASE-KX EEE	1 = EEE is supported for 1000BASE-KX 0 = EEE is not supported for 1000BASE-KX	RO	0
11	LP 10GBASE-T EEE	1 = EEE is supported for 10GBASE-T 0 = EEE is not supported for 10GBASE-T	RO	0
10	LP 1000BASE-T EEE	1 = EEE is supported for 1000BASE-T 0 = EEE is not supported for 1000BASE-T	RO	0
9	LP 100BASE-TX EEE	1 = EEE is supported for 100BASE-TX 0 = EEE is not supported for 100BASE-TX	RO	0
8-2	Reserved	Reserved	RO	7h'0
1	Local 100BASE-TX EEE	1 = EEE is supported for 100BASE-TX 0 = EEE is not supported for 100BASE-TX <b>Note:</b> This is for local port to support EEE capability	R/W	1
0	Reserved	N/A Don't change	RO	0
<b>EEE Port Register 4</b>				
Port EEE Wake Up Error Count Register Register 110 (0x6E) bits [7:5] = 001 for EEE, Register 110 bits [3:0] = 0xn, n = 3-4 for the Indirect Port Register, Register 111 (0x6F) bits [7:0] = Offset to access the Indirect Byte Register 0xA0. Offset: 0x2A (bits [15:8]), 0x2B (bits [7:0]) Location: (001 EEE) → {0xn, offset} → 0xA0 holds the data.				
15-0	EEE Wakeup Error Counter	This count is incremented by one whenever a wakeup from LPI to Idle state is longer than the Wake-Up error threshold time specified in EEE Global Register 4. The default of Wake-Up error threshold time is 20.5µs. This register is read-cleared	RO	0x0000
<b>EEE Port Register 5</b>				
Port EEE Control Register Register 110 (0x6E) bits [7:5]=001 for EEE, Register 110 bits [3:0] = 0xn, n = 3-4 for the Indirect Port Register, Register 111 (0x6F) bits [7:0] = Offset to access the Indirect Byte Register 0xA0. Offset: 0x2C (bits [15:8]), 0x2D (bits [7:0]) Location: (001 EEE) → {0xn, offset} → 0xA0 holds the data.				
15	10BT EEE Disable	1 = 10BT EEE mode is disabled 0 = 10BT EEE mode is enabled <b>Note:</b> 10BT EEE mode saves power by reducing signal amplitude only.	R/W	1
14-8	Reserved	N/A Don't change	RO	7h'0
7	H/W-Based EEE NP Auto-Negotiation Enable	1 = H/W will automatically perform EEE capability exchange with Link Partner through next page exchange. EEE 100BT enable (bit [0] of this register). Will be set by H/W if EEE capability is matched. 0 = H/W based EEE capability exchange is off. EEE capability exchange is done by software.	R/W	1
6	H/W 100BT EEE Enable Status	1 = 100BT EEE is enabled by H/W-based NP exchange 0 = 100BT EEE is disabled	R	0

Address	Name	Description	Mode	Default
5	TX LPI Received	1 = Indicates that the transmit PCS has received low power idle signaling one or more times since the register was last read. 0 = Indicates that the PCS has not received low power idle signaling. This bit is cleared after reading.	R/RC	0
4	TX LPI Indication	1 = Indicates that the transmit PCS is currently receiving low power idle signals. 0 = Indicates that the PCS is not currently receiving low power idle signals.	R	0
3	RX LPI Received	1 = Indicates that the receive PCS has received low power idle signaling one or more times since the register was last read. 0 = Indicates that the PCS has not received low power idle signaling. This bit is cleared after reading.	R/RC	0
2	RX LPI Indication	1 = Indicates that the receive PCS is currently receiving low power idle signals. 0 = Indicates that the PCS is not currently receiving low power idle signals.	R	0
1	EEE SW Mode Enable	1 = EEE is enabled through S/W setting bit [0] of this register. 0 = EEE is enabled through H/W auto-negotiation	R/W	0
0	EEE SW 100BT Enable	1 = EEE 100BT is enabled 0 = EEE 100BT is disabled <b>Note:</b> This bit could be set by S/W or H/W if H/W-based EEE Next Page auto-negotiation enable is on.	R/W	0
<b>EEE Port Register 6</b>				
Port EEE LPI Recovery Time Register Register 110 (0x6E) bits [7:5] = 001 for EEE, Register 110 bits [3:0] = 0xn, n = 3-4 for the Indirect Port Register, Register 111 (0x6F) bits [7:0] = Offset to access the Indirect Byte Register 0xA0. Offset: 0x2E (bits [15:8]), 0x2F (bits [7:0]) Location: (001 EEE) → {0xn, offset} → 0xA0 holds the data.				
15-8	Reserved	Reserved	RO	1
7-0	LPI Recovery Counter	This register specifies the time that the MAC device has to wait before it can start sending out packets. This value should be the maximum of the LPI recovery time between local device and remote device. The unit is 640ns. The default is about 25μs = 39 (0x27) × 640ns <b>Note:</b> This value can be adjusted if the PHY recovery time is less than the standard 20.5μs for the packets to be sent out quickly from EEE LPI mode.	R/W	0x27



## Programming Examples

### **Read Operation**

- Use the Indirect Access Control Register to select register to be read, to read the EEE Global Register 0 (Global EEE QM Buffer Control Register).  
Write 0x30 to the Register 110 (0x6E) // EEE selected and read operation, and 4 MSBs of Port number = 0 for the global register.  
Write 0x30 to the indirect Register 111 (0x6F) // trigger the read operation and ready to read the EEE Global Register 0 bits [15:8].  
Read the Indirect Byte Register 160 (0xA0) //Get the bits [15:8] value of the EEE Global Register 0.

### **Write Operation**

- Write 0x20 to Register 110 (0x6E) // EEE selected and write operation, 4 MSBs of Port number = 0 is for global register.  
Write 0x31 to Register 111 (0x6F) // select the offset address, ready to write the EEE Global Register 0 bits [7:0].  
Write new value to the Indirect Byte Register 160 (0xA0) bits [7:0].

## Management Information Base (MIB) Counters

The MIB counters are provided on a per port basis. These counters are read using indirect memory access as indicated below.

**Table 30. Port 1 MIB Counter Indirect Memory Offers**

Offset	Counter Name	Description
0x0	RxHiPriorityByte	RX hi-priority octet count including bad packets.
0x1	RxUndersizePkt	RX undersize packets w/good CRC.
0x2	RxFragments	RX fragment packets w/bad CRC, symbol errors or alignment errors.
0x3	RxOversize	RX oversize packets w/good CRC (max: 1536 or 1522 bytes).
0x4	RxJabbers	RX packets longer than 1522 bytes w/either CRC errors, alignment errors, or symbol errors (depends on max packet size setting) or RX packets longer than 1916 bytes only.
0x5	RxSymbolError	RX packets w/ invalid data symbol and legal preamble, packet size.
0x6	RxCRCError	RX packets within (64,1522) bytes w/an integral number of bytes and a bad CRC (upper limit depends on max packet size setting).
0x7	RxAlignmentError	RX packets within (64,1522) bytes w/a non-integral number of bytes and a bad CRC (upper limit depends on max packet size setting).
0x8	RxControl8808Pkts	The number of MAC control frames received by a port with 88-08h in EtherType field.
0x9	RxPausePkts	The number of PAUSE frames received by a port. PAUSE frame is qualified with EtherType (88-08h), DA, control opcode (00-01), data length (64 byte min), and a valid CRC.
0xA	RxBroadcast	RX good broadcast packets (not including errored broadcast packets or valid multicast packets).
0xB	RxMulticast	RX good multicast packets (not including MAC control frames, errored multicast packets or valid broadcast packets).
0xC	RxUnicast	RX good unicast packets.
0xD	Rx64Octets	Total RX packets (bad packets included) that were 64 octets in length.
0xE	Rx65to127Octets	Total RX packets (bad packets included) that are between 65 and 127 octets in length.
0xF	Rx128to255Octets	Total RX packets (bad packets included) that are between 128 and 255 octets in length.
0x10	Rx256to511Octets	Total RX packets (bad packets included) that are between 256 and 511 octets in length.
0x11	Rx512to1023Octets	Total RX packets (bad packets included) that are between 512 and 1023 octets in length.
0x12	Rx1024to1522Octets	Total RX packets (bad packets included) that are between 1024 and 1522 octets in length.
0x13	Rx1523to2000Octets	Total RX packets (bad packets included) that are between 1523 and 2000 octets in length.
0x14	Rx2001toMax-1Octets	Total RX packets (bad packets included) that are between 2001 and Max-1 octets in length (upper limit depends on max packet size -1).
0x15	TxHiPriorityByte	TX hi-priority good octet count, including PAUSE packets.
0x16	TxLateCollision	The number of times a collision is detected later than 512 bit-times into the TX of a packet.
0x17	TxPausePkts	The number of PAUSE frames transmitted by a port.
0x18	TxBroadcastPkts	TX good broadcast packets (not including errored broadcast or valid multicast packets).
0x19	TxMulticastPkts	TX good multicast packets (not including errored multicast packets or valid broadcast packets).
0x1A	TxUnicastPkts	TX good unicast packets.
0x1B	TxDeferred	TX packets by a port for which the first TX attempt is delayed due to the busy medium.
0x1C	TxTotalCollision	TX total collision, half-duplex only.
0x1D	TxExcessiveCollision	A count of frames for which TX fails due to excessive collisions.
0x1E	TxSingleCollision	Successfully transmits frames on a port for which TX is inhibited by exactly one collision.
0x1F	TxMultipleCollision	Successfully transmits frames on a port for which TX is inhibited by more than one collision.

**For Port 2, the base is 0x20, same offset definition (0x20-0x3f)**

**For Port 3, the base is 0x40, same offset definition (0x40-0x5f)**

**For Port 4, the base is 0x60, same offset definition (0x60-0x7f)**

**For Port 5, the base is 0x80, same offset definition (0x80-0x9f)**

**Table 31. Format of Per-Port MIB Counters**

Address	Name	Description	Mode	Default
<b>Format of Per-Port MIB Counters</b>				
38	Overflow	1 = Counter overflow. 0 = No Counter overflow.	RO	0
37	Count Valid	1 = Counter value is valid. 0 = Counter value is not valid.	RO	0
36-30	Reserved	N/A No change	RO	All '0'
29-0	Counter Values	Counter value.	RO	0

**Table 32. All Port-Dropped Packet MIB Counters**

Offset	Counter Name	Description
0x100	Port1 RX Total Bytes	Port 1 RX total octet count, including bad packets.
0x101	Port1 TX Total Bytes	Port 1 TX total good octet count, including PAUSE packets.
0x102	Port1 RX Drop Packets	Port 1 RX packets dropped due to lack of resources.
0x103	Port1 TX Drop Packets	Port 1 TX packets dropped due to lack of resources.
0x104	Port2 RX Total Bytes	Port 2 RX total octet count, including bad packets.
0x105	Port2 TX Total Bytes	Port 2 TX total good octet count, including PAUSE packets.
0x106	Port2 RX Drop Packets	Port 2 RX packets dropped due to lack of resources.
0x107	Port2 TX Drop Packets	Port 2 TX packets dropped due to lack of resources.
0x108	Port3 RX Total Bytes	Port 3 RX total octet count, including bad packets.
0x109	Port3 TX Total Bytes	Port 3 TX total good octet count, including PAUSE packets.
0x10A	Port3 RX Drop Packets	Port 3 RX packets dropped due to lack of resources.
0x10B	Port3 TX Drop Packets	Port 3 TX packets dropped due to lack of resources.
0x10C	Port4 RX Total Bytes	Port 4 RX total octet count, including bad packets.
0x10D	Port4 TX Total Bytes	Port 4 TX total good octet count, including PAUSE packets.
0x10E	Port4 RX Drop Packets	Port 4 RX packets dropped due to lack of resources.
0x10F	Port4 TX Drop Packets	Port 4 TX packets dropped due to lack of resources.
0x110	Port5 RX Total Bytes	Port 5 RX total octet count, including bad packets.
0x111	Port5 TX Total Bytes	Port 5 TX total good octet count, including PAUSE packets.
0x112	Port5 RX Drop Packets	Port 5 RX packets dropped due to lack of resources.
0x113	Port5 TX Drop Packets	Port 5 TX packets dropped due to lack of resources.

**Table 33. Format of Per-Port Total RX/TX Bytes MIB Counters**

Address	Name	Description	Mode	Default
<b>Format of Per Port Total Byte MIB Counters</b>				
38	Overflow	1 = Counter overflow. 0 = No Counter overflow.	RO	0
37	Count Valid	1 = Counter value is valid. 0 = Counter value is not valid.	RO	0
36	Reserved	N/A No change	RO	0
35-0	Counter Values	Counter value.	RO	0

**Table 34. Format of All Port Dropped Packet MIB Counters**

Address	Name	Description	Mode	Default
<b>Format of All Port Dropped Packet MIB Counters</b>				
38	Overflow	1 = Counter overflow. 0 = No Counter overflow.	RO	0
37	Count Valid	1 = Counter value is valid. 0 = Counter value is not valid.	RO	0
36-16	Reserved	N/A No change	RO	All '0'
15-0	Counter Values	Counter value.	RO	0

**Note:** All per-port MIB counters are read-clear.

The KSZ8775CLX provides a total of 36 MIB counters per port. These counters are used to monitor the port activity for network management and maintenance. These MIB counters are read using indirect memory access, as shown in the following examples.

Programming Examples:

- MIB counter read (read Port 1 Rx64Octets counter)  
Write to Register 110 with 0x1c (read MIB counters selected)  
Write to Register 111 with 0xd (trigger the read operation)  
Then  
Read Register 116 (counter value [39:32])  
// If bit [38] = 1, there was a counter overflow  
Read Register 117 (counter value [31:24])  
Read Register 118 (counter value [23:16])  
Read Register 119 (counter value [15:8])  
Read Register 120 (counter value [7:0])
- MIB counter read (read Port 2 Rx64Octets counter)  
Write to Register 110 with 0x1c (read MIB counter selected)  
Write to Register 111 with 0x2d (trigger the read operation)  
Then  
Read Register 116 (counter value [39:32])  
// If bit [38] = 1, there was a counter overflow

- Read Register 117 (counter value [31:24])
- Read Register 118 (counter value [23:16])
- Read Register 119 (counter value [15:8])
- Read Register 120 (counter value [7:0])
- MIB counter read (read Port 1 TX drop packets)
  - Write to Register 110 with 0x1d
  - Write to Register 111 with 0x03
  - Then
  - Read Register 116 (counter value [39:32])
  - // If bit [38] = 1, there was a counter overflow
  - Read Register 119 (counter value [15:8])
  - Read Register 120 (counter value [7:0])

To read out all the counters, the best performance over the SPI bus is  $(160+3) \times 8 \times 20 = 26\mu\text{s}$ , where there are 160 registers, 3 overhead, 8 clocks per access, at 50MHz. In the heaviest condition, the byte counter will overflow in 2 minutes. It is recommended that the software read all the counters at least every 30 seconds. The all-port MIB counters are designed as read-clear.

## MIIM Registers

All the registers defined in this section can be also accessed via the SPI interface. Note that different mapping mechanisms are used for MIIM and SPI. The “PHYAD” defined in IEEE is assigned as “0x1” for Port 1, “0x2” for Port 2, “0x3” for Port 3, and “0x4” for Port 4. The “REGAD” supported are 0x0-0x5 (0h-5h), 0x1D (1dh) and 0x1F (1fh).

Address	Name	Description	Mode	Default
<b>Register 0h: Basic Control</b>				
15	Soft Reset	1 = PHY soft reset. 0 = Normal operation.	R/W (SC)	0
14	Loopback	1 = Perform MAC loopback. Loopback path is as follows: Assume the loopback is at Port 1 MAC, Port 2 is the monitor Port. Port 1 MAC loopback (Port 1 Reg. 0, bit [14] = '1') Start: RXP2/RXM2 (Port 2). Can also start from Port 3, 4, 5 Loopback: MAC/PHY interface of Port 1's MAC End: TXP2/TXM2 (Port 2). Can also end at Ports 3, 4, 5 respectively Setting address 0x3, 4, 5 Reg. 0, bit [14] = '1' will perform MAC loopback on Ports 3, 4, 5. respectively. 0 = Normal Operation.	R/W	0
13	Force 100	1 = 100Mbps. 0 = 10Mbps.	R/W	1
12	AN Enable	1 = Auto-Negotiation enabled. 0 = Auto-Negotiation disabled.	R/W	1
11	Power Down	1 = Power down. 0 = Normal operation.	R/W	0
10	PHY Isolate	1 = Electrical PHY isolation of PHY from TX+/TX-. 0 = Normal operation.	R/W	0
9	Restart AN	1 = Restart Auto-Negotiation. 0 = Normal operation.	R/W	0
8	Force Full Duplex	1 = Full-duplex. 0 = Half-duplex.	R/W	1
7	Reserved	Reserved	RO	0
6	Reserved	Reserved	RO	0
5	Hp_mdix	1 = HP Auto-MDI/MDIX mode 0 = Micrel Auto-MDI/MDIX mode	R/W	1
4	Force MDI	1 = MDI mode when disable Auto-MDI/MDIX. 0 = MDIX mode when disable Auto-MDI/MDIX.	R/W	0
3	Disable Auto MDI/MDI-X	1 = Disable Auto-MDI/MDIX. 0 = Enable Auto-MDI/MDIX.	R/W	0
2	Disable far End fault	1 = Disable far end fault detection. 0 = Normal operation.	R/W	0
1	Disable Transmit	1 = Disable transmit. 0 = Normal operation.	R/W	0
0	Disable LED	1 = Disable LED. 0 = Normal operation.	R/W	0

**MIIM Registers (Continued)**

Address	Name	Description	Mode	Default
<b>Register 1h: Basic Status</b>				
15	T4 Capable	0 = Not 100 BASE-T4 capable.	RO	0
14	100 Full Capable	1 = 100BASE-TX full-duplex capable. 0 = Not capable of 100BASE-TX full-duplex.	RO	1
13	100 Half Capable	1 = 100BASE-TX half-duplex capable. 0 = Not 100BASE-TX half-duplex capable.	RO	1
12	10 Full Capable	1 = 10BASE-T full-duplex capable. 0 = Not 10BASE-T full-duplex capable.	RO	1
11	10 Half Capable	1 = 10BASE-T half-duplex capable. 0 = 10BASE-T half-duplex capable.	RO	1
10-7	Reserved	Reserved	RO	0
6	Reserved	Reserved	RO	0
5	AN Complete	1 = Auto-Negotiation complete. 0 = Auto-Negotiation not completed.	RO	0
4	Far End fault	1 = Far end fault detected. 0 = No far end fault detected.	RO	0
3	AN Capable	1 = Auto-Negotiation capable. 0 = Not Auto-Negotiation capable.	RO	1
2	Link Status	1 = Link is up. 0 = Link is down.	RO	0
1	Reserved	Reserved	RO	0
0	Extended Capable	0 = Not extended register capable.	RO	0
<b>Register 2h: PHYID HIGH</b>				
15-0	Phyid High	High order PHYID bits.	RO	0x0022
<b>Register 3h: PHYID LOW</b>				
15-0	Phyid Low	Low order PHYID bits.	RO	0x1550
<b>Register 4h: Advertisement Ability</b>				
15	Reserved	Reserved	RO	0
14	Reserved	Reserved	RO	0
13	Reserved	Reserved	RO	0
12-11	Reserved	Reserved	RO	01
10	Pause	1 = Advertise pause ability. 0 = Do not advertise pause ability.	R/W	1
9	Reserved	Reserved	R/W	0
8	Adv 100 Full	1 = Advertise 100 full-duplex ability. 0 = Do not advertise 100 full-duplex ability.	R/W	1
7	Adv 100 Half	1 = Advertise 100 half-duplex ability. 0 = Do not advertise 100 half-duplex ability.	R/W	1
6	Adv 10 Full	1 = Advertise 10 full-duplex ability. 0 = Do not advertise 10 full-duplex ability.	R/W	1
5	Adv 10 Half	1 = Advertise 10 half-duplex ability. 0 = Do not advertise 10 half-duplex ability.	R/W	1
4-0	Selector Field	[00001] = IEEE 802.3	RO	00001

**MIIM Registers (Continued)**

Address	Name	Description	Mode	Default
<b>Register 5h: Link Partner Ability</b>				
15	Reserved	Reserved	RO	0
14	Reserved	Reserved	RO	0
13	Reserved	Reserved	RO	0
12-11	Reserved	Reserved	RO	0
10	Pause	1 = Link partner flow control capable. 0 = Link partner not flow control capable.	RO	0
9	Reserved	Reserved	RO	0
8	Adv 100 Full	1 = Link partner 100BT full-duplex capable. 0 = Link partner not 100BT full-duplex capable.	RO	0
7	Adv 100 Half	1 = Link partner 100BT half-duplex capable. 0 = Link partner not 100BT half-duplex capable.	RO	0
6	Adv 10 Full	1 = Link partner 10BT full-duplex capable. 0 = Link partner not 10BT full-duplex capable.	RO	0
5	Adv 10 Half	1 = Link partner 10BT half-duplex capable. 0 = Link partner not 10BT half-duplex capable.	RO	0
4-0	Reserved	Reserved	RO	00001
<b>Register 1dh: LinkMD Control/Status</b>				
15	Cable Diagnostic Test CDT_Enable	1 = Enable cable diagnostic. After CDT test has completed, this bit will be self-cleared. 0 = Indicates cable diagnostic test (if enabled) has completed and the status information is valid for reading.	R/W (SC)	0
14-13	CDT_Result	00 = Normal condition 01 = Open condition detected in cable 10 = Short condition detected in cable 11 = Cable diagnostic test has failed	RO	00
12	CDT 10M Short	1 = Less than 10 meter short	RO	0
11-9	Reserved	Reserved	RO	0
8-0	CDT_Fault_Count	Distance to the fault. Approximately 0.4m x CDT_Fault_Count[8:0]	RO	00000000
<b>Register 1fh: PHY Special Control/Status</b>				
15-11	Reserved		RO	000000000
10-8	Port Operation Mode Indication	Indicate the current state of port operation mode: 000 = Reserved 001 = Still in auto-negotiation 010 = 10BASE-T half-duplex 011 = 100BASE-TX half-duplex 100 = Reserved 101 = 10BASE-T full-duplex 110 = 100BASE-TX full-duplex 111 = PHY/MII isolate	RO	001
7-6	Reserved	N/A Don't change	RO	00
5	Polrvs	1 = Polarity is reversed 0 = Polarity is not reversed	RO	0
4	MDI-X status	1 = MDI 0 = MDI-X	RO	0



**MIIM Registers (Continued)**

Address	Name	Description	Mode	Default
3	Force_Ink	1 = Force link pass 0 = Normal operation	R/W	0
2	Pwrsave	1 = Enable power save 0 = Disable power save	R/W	0
1	Remote Loopback	1 = Perform Remote loopback. Loopback path is as follows: Port 1 (PHY ID address 0x1 Reg. 1fh, bit [1] = '1') Start: RXP1/RXM1 (Port 1) Loopback: PMD/PMA of Port 1's PHY End: TXP1/TXM1 (Port 1) Setting PHY ID address 0x2, 3, 4, 5 Reg. 1fh bit [1] = '1', will perform remote loopback on Port 2, 3, 4, 5. 0 = Normal operation.	R/W	0
0	Reserved	Reserved	RO	0

### Absolute Maximum Ratings<sup>(9)</sup>

Supply Voltage ( $V_{DD12A}$ , $V_{DD12D}$ ).....	-0.5V to +1.8V
( $V_{DDAT}$ , $V_{DDIO}$ ) .....	-0.5V to +4.0V
Input Voltage .....	-0.5V to +4.0V
Output Voltage .....	-0.5V to +4.0V
Lead Temperature (soldering, 10s).....	260°C
Storage Temperature ( $T_s$ ).....	-55°C to +150°C
Maximum Junction Temperature ( $T_J$ ).....	125°C
HBM ESD Rating <sup>(11)</sup> .....	5kV

### Operating Ratings<sup>(10)</sup>

Supply Voltage ( $V_{DD12A}$ , $V_{DD12D}$ ) .....	+1.140V to +1.260V
( $V_{DDAT}$ ).....	+3.135V to +3.465V
( $V_{DDIO}$ @ 3.3V) .....	+3.135V to +3.465V
( $V_{DDIO}$ @ 2.5V) .....	+2.375V to +2.625V
( $V_{DDIO}$ @ 1.8V) .....	+1.710V to +1.890V
Ambient Temperature ( $T_A$ )	
Commercial.....	0°C to +70°C
Industrial .....	-40°C to +85°C
Junction Thermal Resistance <sup>(12)</sup>	
Thermal Resistance ( $\theta_{JA}$ ).....	55.05°C/W
Thermal Resistance ( $\theta_{JC}$ ) .....	25.06°C/W

### Electrical Characteristics<sup>(13)</sup>

$V_{IN} = 1.2V/3.3V$ ;  $T_A = 25^\circ C$ .

Symbol	Parameter	Condition	Min.	Typ.	Max.	Units
<b>100BASE-TX Operation – All Ports 100% Utilization</b>						
$I_{DX}$	100BASE-TX (Transmitter) 3.3V Analog	$V_{DDAT}$		106		mA
$I_{D12}$	100BASE-TX 1.2V	$V_{DD12A} + V_{DD12D}$		38		mA
$I_{DDIO}$	100BASE-TX (Digital IO) 3.3V Digital	$V_{DDIO}$		22		mA
<b>10BASE-T Operation – All Ports 100% Utilization</b>						
$I_{DX}$	10BASE-T (Transmitter) 3.3V Analog	$V_{DDAT}$		108		mA
$I_{D12}$	10BASE-T 1.2V	$V_{DD12A} + V_{DD12D}$		32		mA
$I_{DDIO}$	10BASE-T (Digital IO) 3.3V Digital	$V_{DDIO}$		18		mA
<b>Auto-Negotiation Mode</b>						
$I_{DX}$	3.3V Analog	$V_{DDAT}$		50		mA
$I_{D12}$	1.2V Analog/Digital	$V_{DD12A} + V_{DD12D}$		35		mA
$I_{DDIO}$	3.3V Digital	$V_{DDIO}$		17		mA

**Notes:**

9. Exceeding the absolute maximum ratings may damage the device.
10. The device is not guaranteed to function outside its operating ratings. Unused inputs must always be tied to an appropriate logic voltage level (GND or VDD).
11. Devices are ESD sensitive. Handling precautions are recommended. Human body model, 1.5kΩ in series with 100pF.
12. No heat spreader in package. The thermal junction to ambient ( $\theta_{JA}$ ) and the thermal junction to case ( $\theta_{JC}$ ) are under air velocity 0m/s.
13. Specification for packaged product only. There is not additional transformer consumption due to the use of on-chip termination technology with internal biasing for 10Base-T and 100Base-TX. The test condition is in Port 5 RGMII mode (default). Measurements were taken with operating ratings.

## Electrical Characteristics (Continued)

$V_{IN} = 1.2V/3.3V$ ;  $T_A = 25^\circ C$ .

Symbol	Parameter	Condition	Min.	Typ.	Max.	Units
<b>Power Management Mode</b>						
$I_{SPDM1}$	Soft Power Down Mode 3.3V	$V_{DDAT} + V_{DDIO}$		0.8		mA
$I_{SPDM2}$	Soft Power Down Mode 1.2V	$V_{DD12A} + V_{DD12D}$		1.5		mA
$I_{EDM1}$	Energy Detect Mode (EDPD) 3.3V	$V_{DDAT} + V_{DDIO}$		25		mA
$I_{EDM2}$	Energy Detect Mode (EDPD) 1.2V	$V_{DD12A} + V_{DD12D}$		29		mA
$I_{EEE1}$	100BT EEE Mode at Idle 3.3V	$V_{DDAT} + V_{DDIO}$		26		mA
$I_{EEE2}$	100BT EEE Mode at Idle 1.2V	$V_{DD12A} + V_{DD12D}$		29		mA
<b>CMOS Inputs</b>						
$V_{IH}$	Input High Voltage	$V_{DDIO} = 3.3V$	2.0			V
		$V_{DDIO} = 2.5V$	1.8			V
		$V_{DDIO} = 1.8V$	1.3			V
$V_{IL}$	Input Low Voltage	$V_{DDIO} = 3.3V$			0.8	V
		$V_{DDIO} = 2.5V$			0.7	V
		$V_{DDIO} = 1.8V$			0.5	V
$I_{IN}$	Input Current (Excluding Pull-Up/Pull-Down)	$V_{IN} = GND \sim V_{DDIO}$			10	$\mu A$
<b>CMOS Outputs</b>						
$V_{OH}$	Output High Voltage	$V_{DDIO} = 3.3V$	2.4			V
		$V_{DDIO} = 2.5V$	2.0			V
		$V_{DDIO} = 1.8V$	1.5			V
$V_{OL}$	Output Low Voltage	$V_{DDIO} = 3.3V$			0.4	V
		$V_{DDIO} = 2.5V$			0.4	V
		$V_{DDIO} = 1.8V$			0.3	V
$I_{OZ}$	Output Tri-State Leakage	$V_{IN} = GND \sim V_{DDIO}$			10	$\mu A$
<b>100BASE-TX Transmit (Measured Differentially After 1:1 Transformer)</b>						
$V_O$	Peak Differential Output Voltage	100 $\Omega$ termination on the differential output	0.95		1.05	V
$V_{IMB}$	Output Voltage Imbalance	100 $\Omega$ termination on the differential output			2	%
$t_r/t_f$	Rise/Fall Time		3		5	ns
	Rise/Fall Time Imbalance		0		0.5	ns
	Duty Cycle Distortion				$\pm 0.5$	ns
	Overshoot				5	%
	Output Jitters	Peak-to-peak	0	0.75	1.4	ns

**Electrical Characteristics (Continued)** $V_{IN} = 1.2V/3.3V$ ;  $T_A = 25^{\circ}C$ .

Symbol	Parameter	Condition	Min.	Typ.	Max.	Units
<b>10BASE-T Receive</b>						
$V_{SQ}$	Squelch Threshold	5MHz square wave	300	400	585	mV
<b>10BASE-T Transmit (Measured Differentially After 1:1 Transformer) <math>V_{DDAT} = 3.3V</math></b>						
$V_P$	Peak Differential Output Voltage	100 $\Omega$ termination on the differential output	2.2	2.5	2.8	V
	Output Jitters	Peak-to-peak		1.4	3.5	ns
$t_r/t_f$	Rise/Fall Times			28	30	ns
<b>I/O Pin Internal Pull-Up and Pull-Down Resistance</b>						
R1.8PU	I/O Pin Effective Pull-Up Resistance	$V_{DDIO} = 1.8V$	75	95	135	k $\Omega$
R1.8PD	I/O Pin Effective Pull-Down Resistance	$V_{DDIO} = 1.8V$	53	68	120	k $\Omega$
R2.5PU	I/O Pin Effective Pull-Up Resistance	$V_{DDIO} = 2.5V$	46	60	93	k $\Omega$
R2.5PD	I/O Pin Effective Pull-Down Resistance	$V_{DDIO} = 2.5V$	46	59	103	k $\Omega$
R3.3PU	I/O Pin Effective Pull-Up Resistance	$V_{DDIO} = 3.3V$	35	45	65	k $\Omega$
R3.3PD	I/O Pin Effective Pull-Down Resistance	$V_{DDIO} = 3.3V$	37	46	74	k $\Omega$

## Timing Diagram

### RGMIITiming

The RGMIITiming conforms to the timing requirements in the RGMIITiming Version 2.0 specification.

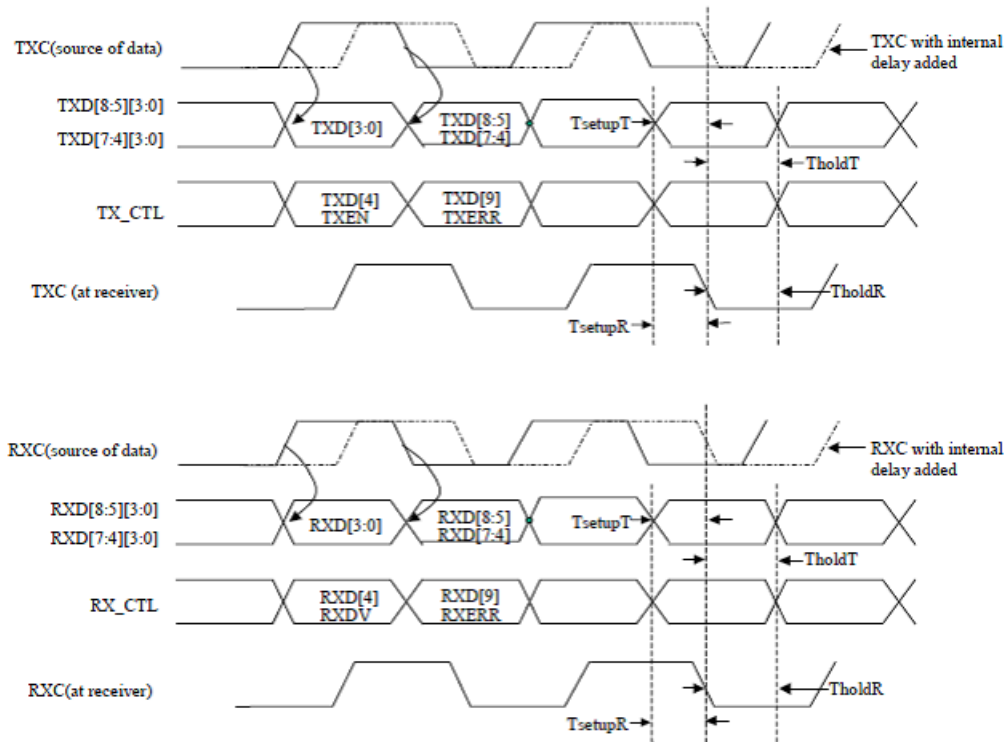

Figure 16. RGMIITiming v2.0 Specification

Table 35. RGMIITiming v2.0 Specification

Symbol	Parameter	Min	Typ	Max	Units
TskewT	Data to clock output skew (at transmitter) <sup>(14)</sup>	-500	0	500	ps
TskewR	Data to clock input skew (at receiver) <sup>(14)</sup>	1		2.6	ns
Tcyc	Clock Cycle Duration <sup>(15)</sup>	7.2	8	8.8	ns
Duty_G	Duty Cycle for Gigabit	45	50	55	%
Duty_T	Duty Cycle for 10/100T	40	50	60	%
t <sub>r</sub> /t <sub>f</sub>	Rise/Fall Time (20-80%)			0.75	ns

**Notes:**

- 14. RGMIITiming v2.0 adds an internal delay (RGMIIT-ID) option to match the clock's timing for transmitting and receiving.
- 15. For 10Mbps and 100Mbps, Tcyc scales to 400ns ±40ns and 40ns ±4ns.

**MII Timing**

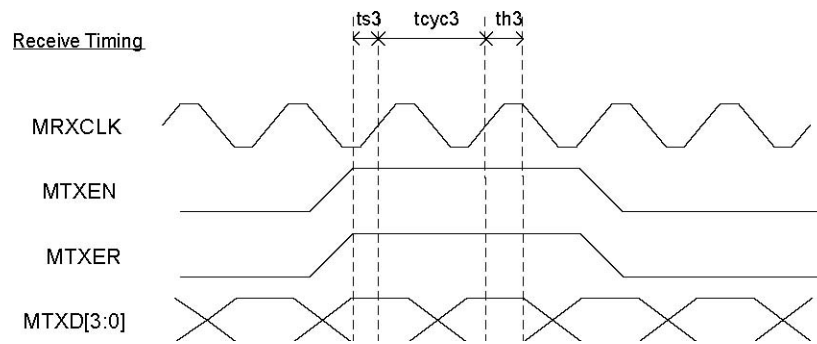

**Figure 17. MAC Mode MII Timing – Data Received from MII**

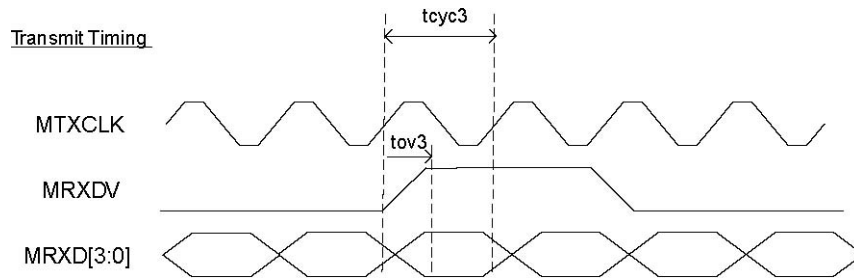

**Figure 18. MAC Mode MII Timing – Data Transmitted from MII**

**Table 36. MAC Mode MII Timing Parameters**

Symbol	Parameter	10BASE-T/100BASE-TX			Units
		Min.	Typ.	Max.	
$t_{cyc3}$	Clock Cycle		400/40		ns
$t_{s3}$	Set-Up Time	2			ns
$t_{H3}$	Hold Time	2			ns
$t_{ov3}$	Output Valid	3	8	10	ns

MII Timing (Continued)

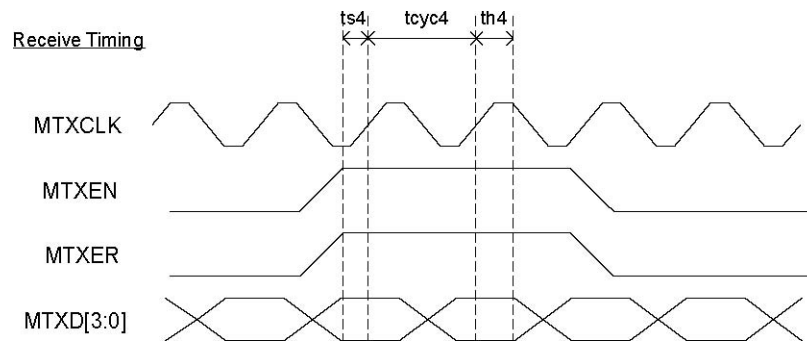

Figure 19. PHY Mode MII Timing – Data Received from MII

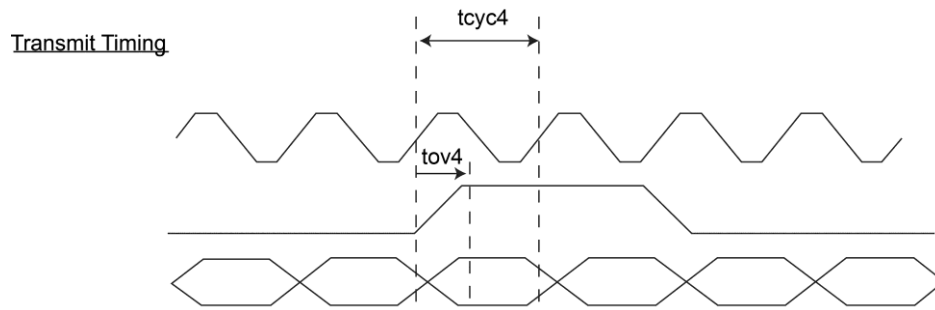
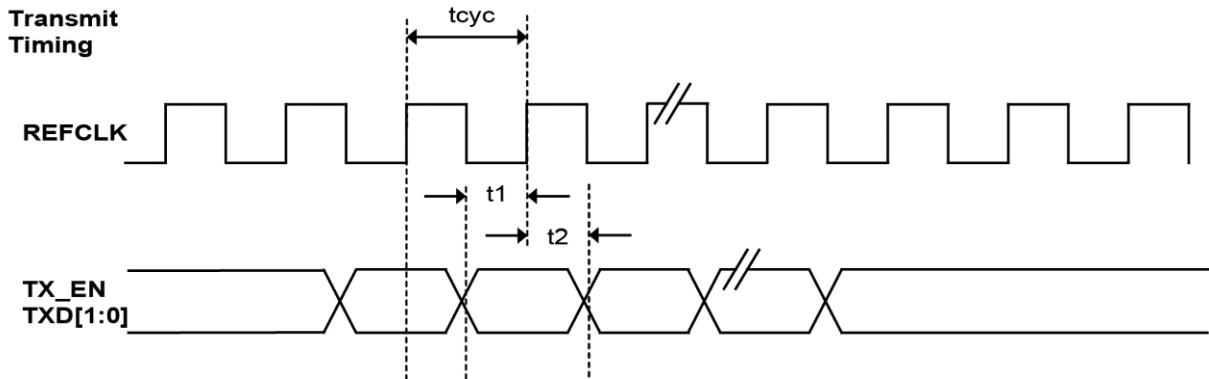

Figure 20. PHY Mode MII Timing – Data Transmitted from MII

Table 37. PHY Mode MII Timing Parameters

		10BASE-T/100BASE-TX			
Symbol	Parameter	Min.	Typ.	Max.	Units
$t_{cyc4}$	Clock Cycle		400/40		ns
$t_{s4}$	Set-Up Time	10			ns
$t_{H4}$	Hold Time	0			ns
$t_{ov4}$	Output Valid	16	20	25	ns

**RMII Timing**



**Figure 21. RMII Timing – Data Received from RMII**

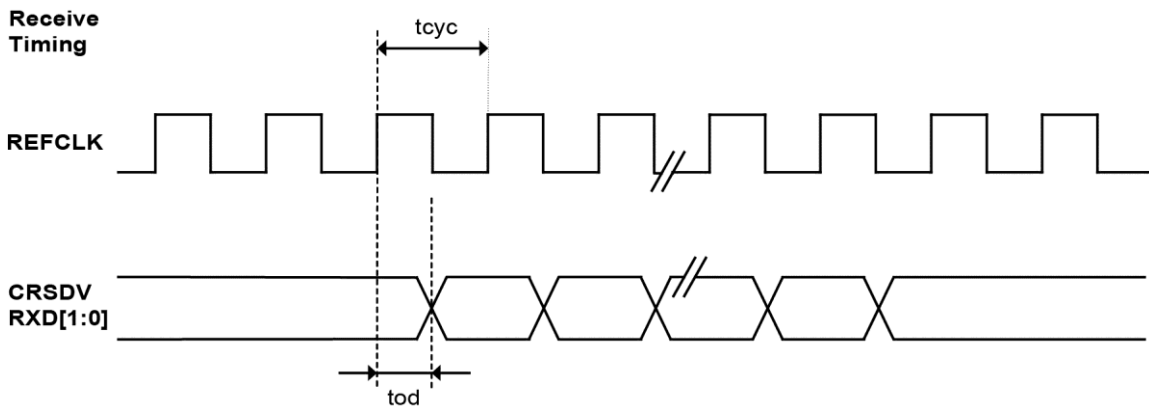

**Figure 22. RMII Timing – Data Transmitted to RMII**

**Table 38. RMII Timing Parameters**

Symbol	Parameter	Min.	Typ.	Max.	Units
t <sub>cyc</sub>	Clock Cycle		20		ns
t <sub>1</sub>	Set-Up Time	4			ns
t <sub>2</sub>	Hold Time	2			ns
t <sub>OD</sub>	Output Delay	3		10	ns



**SPI Timing**

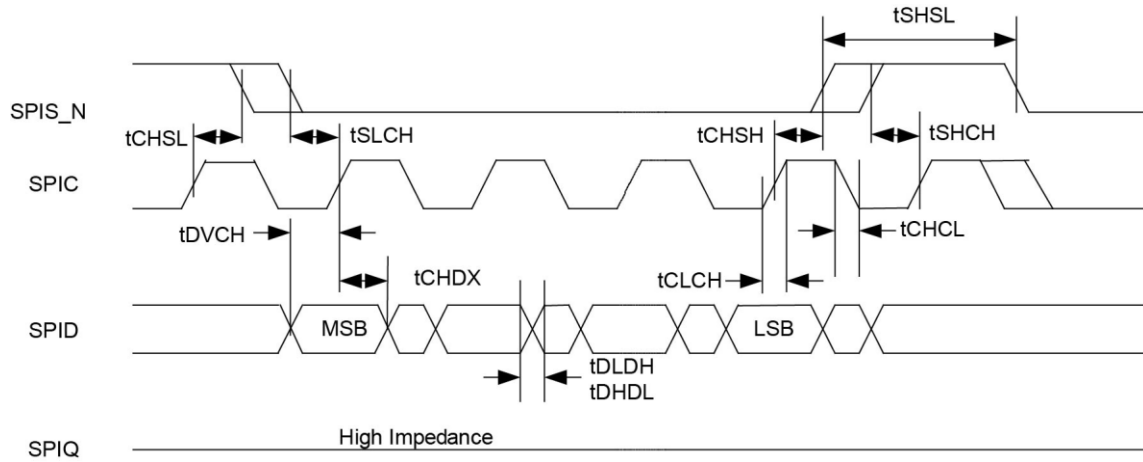
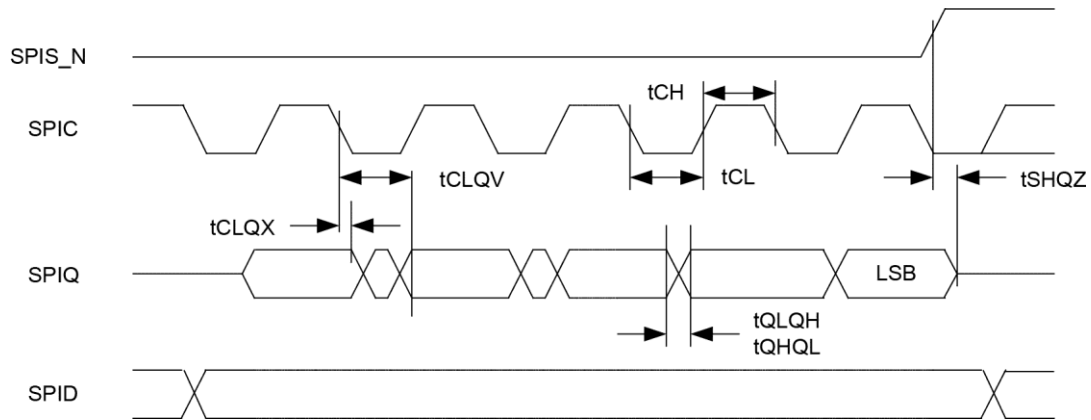

**Figure 23. SPI Input Timing**

**Table 39. SPI Input Timing Parameters**

Symbol	Parameter	Min.	Typ.	Max.	Units
$f_c$	Clock Frequency			50	MHz
$t_{CHSL}$	SPIS_N Inactive Hold Time	2			ns
$t_{SLCH}$	SPIS_N Active Set-Up Time	4			ns
$t_{CHSH}$	SPIS_N Active Hold Time	2			ns
$t_{SHCH}$	SPIS_N Inactive Set-Up Time	4			ns
$t_{SHSL}$	SPIS_N Deselect Time	10			ns
$t_{DVCH}$	Data Input Set-Up Time	4			ns
$t_{CHDX}$	Data Input Hold Time	2			ns
$t_{CLCH}$	Clock Rise Time			1	$\mu$ s
$t_{CHCL}$	Clock fall Time			1	$\mu$ s
$t_{DLDH}$	Data Input Rise Time			1	$\mu$ s
$t_{DHDL}$	Data Input fall Time			1	$\mu$ s

**SPI Timing (Continued)**



**Figure 24. SPI Output Timing**

**Table 40. SPI Output Timing Parameters**

Symbol	Parameter	Min.	Typ.	Max.	Units
$f_c$	Clock Frequency			50	MHz
$t_{CLQX}$	SPIQ Hold Time	0		0	ns
$t_{CLQV}$	Clock Low to SPIQ Valid			60	ns
$t_{CH}$	Clock High Time	9			ns
$t_{CL}$	Clock Low Time	9			ns
$t_{QLQH}$	SPIQ Rise Time			50	ns
$t_{QHQL}$	SPIQ fall Time			50	ns
$t_{SHQZ}$	SPIQ Disable Time			15	ns

Auto-Negotiation Timing

Auto-Negotiation - Fast Link Pulse Timing

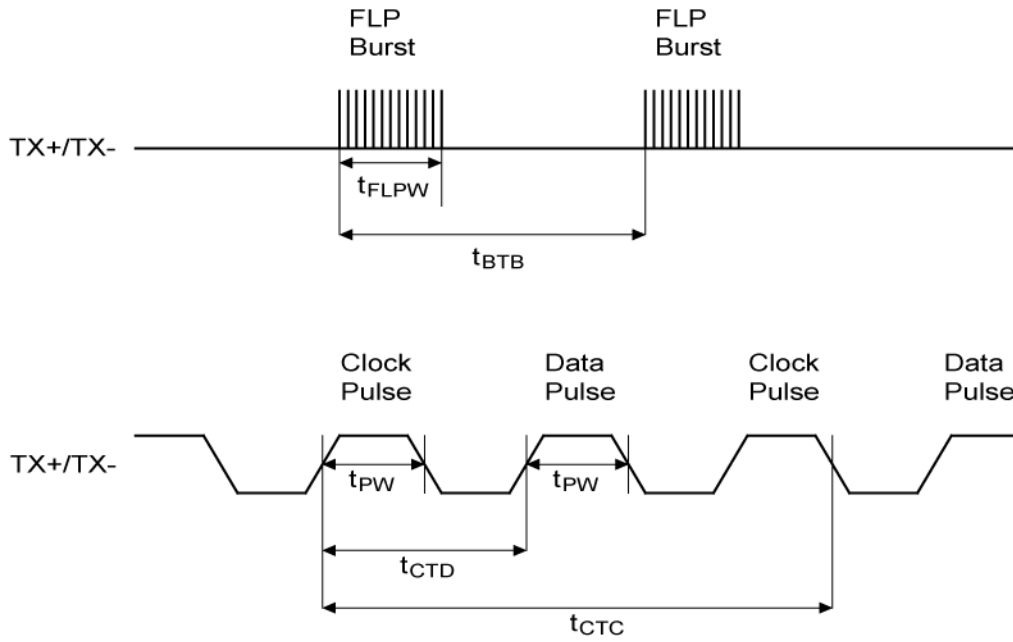
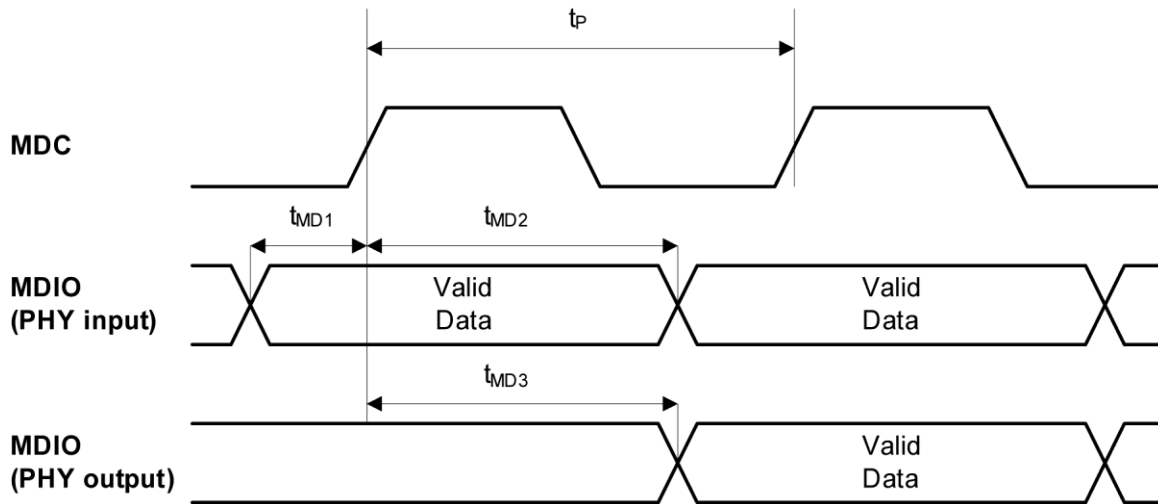

Figure 25. Auto-Negotiation Timing Diagram

Table 41. Auto-Negotiation Timing Parameters

Symbol	Parameter	Min.	Typ.	Max.	Units
$t_{BTB}$	FLP burst to FLP burst	8	16	24	ms
$t_{FLPW}$	FLP burst width		2		ms
$t_{PW}$	Clock/Data pulse width		100		ns
$t_{CTD}$	Clock pulse to Data pulse	55.5	64	69.5	$\mu$ s
$t_{CTC}$	Clock pulse to Clock pulse	111	128	139	$\mu$ s
	Number of Clock/Data pulses per burst	17		33	

**MDC/MDIO Timing**

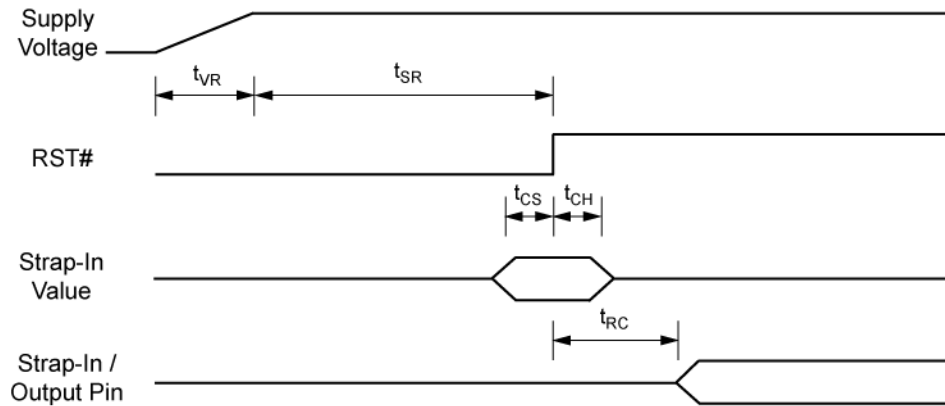

**Figure 26. MDC/MDIO Timing Diagram**

**Table 42. MDC/MDIO Timing Parameters**

Symbol	Parameter	Min.	Typ.	Max.	Units
$t_P$	MDC Period		400		ns
$t_{MD1}$	MDIO (PHY Input) Setup to Rising Edge of MDC	10			ns
$t_{MD2}$	MDIO (PHY Input) Hold from Rising Edge of MDC	4			ns
$t_{MD3}$	MDIO (PHY Output) Delay from Rising Edge of MDC	5			ns

**Power-Down/Power-Up and Reset Timing**



**Figure 27. Reset Timing Diagram**

**Table 43. Reset Timing Parameters**

Symbol	Parameter	Min.	Typ.	Max.	Units
$t_{SR}$	Stable Supply Voltages to Reset High	10			ms
$t_{CS}$	Configuration Set-Up Time	5			ns
$t_{CH}$	Configuration Hold Time	5			ns
$t_{RC}$	Reset to Strap-In Pin Output	6			ns
$t_{VR}$	3.3V Rise Time	200			$\mu$ s

**Reset Circuit Diagram**

Micrel recommends the following discrete reset circuit as shown in Figure 28 when powering up the KS8775 device. For the application where the reset circuit signal comes from another device (e.g., CPU, FPGA, etc.), Micrel recommends the reset circuit as shown in Figure 29.

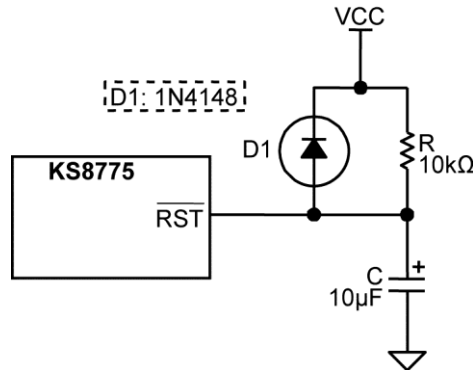

**Figure 28. Recommended Reset Circuit**

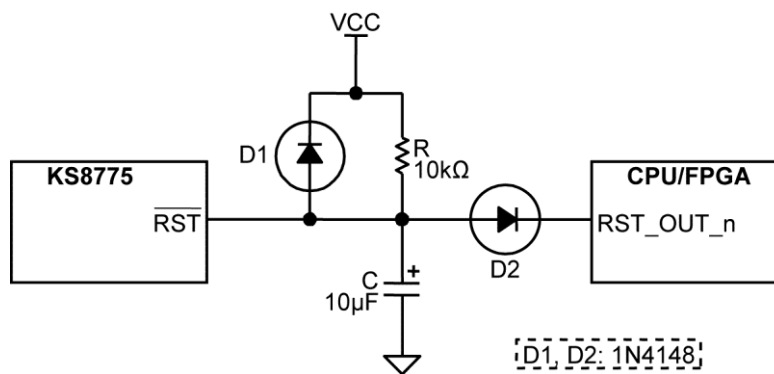

**Figure 29. Recommended Circuit for Interfacing with CPU/FPGA Reset**

At power-on-reset, R, C, and D1 provide the necessary ramp rise time to reset the Micrel device. The reset out RST\_OUT\_n from CPU/FPGA provides the warm reset after power up.

## Selection of Isolation Transformer<sup>(16)</sup>

One simple 1:1 isolation transformer is needed at the line interface. An isolation transformer with integrated common-mode choke is recommended for exceeding FCC requirements at line side. Request to separate the center taps of RX/TX at chip side. The following table gives recommended transformer characteristics.

**Table 44. Transformer Selection Criteria**

Characteristic	Value	Test Condition
Turns Ratio	1CT:1CT	
Open-Circuit Inductance (min.)	350 $\mu$ H	100mV, 100kHz, 8mA
Insertion Loss (max.)	1.1dB	0.1MHz to 100MHz
HIPOT (min.)	1500V <sub>RMS</sub>	

**Note:**

16. The IEEE 802.3u standard for 100BASE-TX assumes a transformer loss of 0.5dB. For the transmit line transformer, insertion loss of up to 1.3dB can be compensated by increasing the line drive current by means of reducing the ISET resistor value.

The following transformer vendors provide compatible magnetic parts for Micrel's device.

**Table 45. Qualified Magnetic Vendors**

Vendors and Parts		Auto MDIX	Number of Ports	Vendors and Parts		Auto MDIX	Number of Ports
Pulse	H1164NL	Yes	4	Pulse	H1102	Yes	1
YCL	PH406082	Yes	4	Bel Fuse	S558-5999-U7	Yes	1
TDK	TLA-6T718A	Yes	1	YCL	PT163020	Yes	1
LanKom	LF-H41S	Yes	1	Transpower	HB726	Yes	1
Datatronic	NT79075	Yes	1	Delta	LF8505	Yes	1

## Selection of Reference Crystal

**Table 46. Typical Reference Crystal Characteristics**

Characteristics	Value	Units
Frequency	25.0	MHz
Frequency Tolerance (max.)	$\leq\pm 50$	ppm
Load Capacitance (max.) <sup>(17)</sup>	27	pF
Series Resistance (max. ESR)	40	$\Omega$

**Note:**

17. Typical value varies per specific crystal specs.

Package Information<sup>(18)</sup>

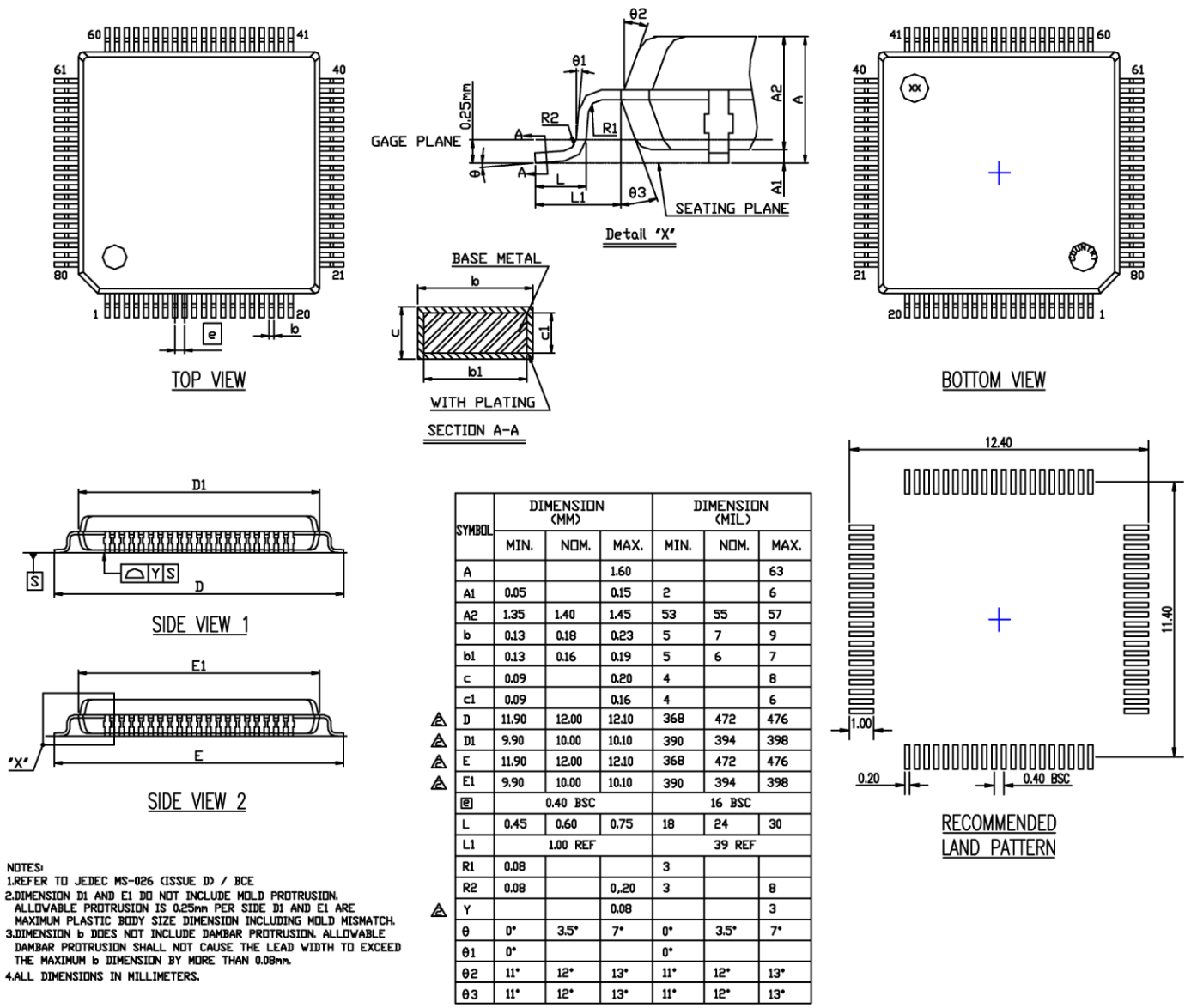

Figure 30. 80-Pin LQFP

Note:

18. Package information is correct as of the publication date. For updates and most current information, go to [www.micrel.com](http://www.micrel.com).



---

**MICREL, INC. 2180 FORTUNE DRIVE SAN JOSE, CA 95131 USA**  
TEL +1 (408) 944-0800 FAX +1 (408) 474-1000 WEB <http://www.micrel.com>

Micrel makes no representations or warranties with respect to the accuracy or completeness of the information furnished in this data sheet. This information is not intended as a warranty and Micrel does not assume responsibility for its use. Micrel reserves the right to change circuitry, specifications and descriptions at any time without notice. No license, whether express, implied, arising by estoppel or otherwise, to any intellectual property rights is granted by this document. Except as provided in Micrel's terms and conditions of sale for such products, Micrel assumes no liability whatsoever, and Micrel disclaims any express or implied warranty relating to the sale and/or use of Micrel products including liability or warranties relating to fitness for a particular purpose, merchantability, or infringement of any patent, copyright or other intellectual property right.

Micrel Products are not designed or authorized for use as components in life support appliances, devices or systems where malfunction of a product can reasonably be expected to result in personal injury. Life support devices or systems are devices or systems that (a) are intended for surgical implant into the body or (b) support or sustain life, and whose failure to perform can be reasonably expected to result in a significant injury to the user. A Purchaser's use or sale of Micrel Products for use in life support appliances, devices or systems is a Purchaser's own risk and Purchaser agrees to fully indemnify Micrel for any damages resulting from such use or sale.

© 2014 Micrel, Incorporated.



## Стандарт Электрон Связь

Мы молодая и активно развивающаяся компания в области поставок электронных компонентов. Мы поставляем электронные компоненты отечественного и импортного производства напрямую от производителей и с крупнейших складов мира.

Благодаря сотрудничеству с мировыми поставщиками мы осуществляем комплексные и плановые поставки широчайшего спектра электронных компонентов.

Собственная эффективная логистика и склад в обеспечивает надежную поставку продукции в точно указанные сроки по всей России.

Мы осуществляем техническую поддержку нашим клиентам и предпродажную проверку качества продукции. На все поставляемые продукты мы предоставляем гарантию .

Осуществляем поставки продукции под контролем ВП МО РФ на предприятия военно-промышленного комплекса России , а также работаем в рамках 275 ФЗ с открытием отдельных счетов в уполномоченном банке. Система менеджмента качества компании соответствует требованиям ГОСТ ISO 9001.

Минимальные сроки поставки, гибкие цены, неограниченный ассортимент и индивидуальный подход к клиентам являются основой для выстраивания долгосрочного и эффективного сотрудничества с предприятиями радиоэлектронной промышленности, предприятиями ВПК и научно-исследовательскими институтами России.

С нами вы становитесь еще успешнее!

### Наши контакты:

**Телефон:** +7 812 627 14 35

**Электронная почта:** [sales@st-electron.ru](mailto:sales@st-electron.ru)

**Адрес:** 198099, Санкт-Петербург,  
Промышленная ул, дом № 19, литера Н,  
помещение 100-Н Офис 331