



Microtips Technology Inc.

台北縣汐止鎮康寧街169巷31號12樓
12F, No 31, Lane 169, Kang Ning St.
Hsi-Chih, Taipei Hsien, Taiwan, R.O.C.





WEB : <http://www.microtips.com.tw>
E-mail : Macros@microtips.com.tw
TEL: 886-2-2695-3133 FAX :886-2-2695-8625

LCD MODULE SPECIFICATION FOR CUSTOMER'S APPROVAL

CUSTOMER : _____

MODULE TYPE : NMTG-S12232BFYHSAY

APPROVED BY: (FOR CUSTOMER USE ONLY)

Approved by	Checked by		Made by
			

CONTENTS

ITEM	PAGE
FEATURES	3
LCD MODULE DRAWING	4
GENERAL SPECIFICATION	5
ABSOLUTE MAXIMUM RATING	5
ELECTRICAL CHARACTERISTICS	6
OPTICAL CHARACTERISTICS	6
MECHANICAL SPECIFICATION	7
INTERFACE PIN ASSIGNMENT	8
BLOCK DIAGRAM	11
TIMING CHARACTERISTICS	12
DISPLAY DATA RAM ADDRESSING	14
DISPLAY COMMANDS	15
COMMAND DESCRIPTION	16
INITIALIZATION PROCEDURE	20
RELIABILITY TEST	21
APPEARANCE CHECK	21
HANDLING PRECAUTIONS	22
LCD PRODUCT QUALITY STANDARD	23
REVISION HISTORY	24

SPECIFICATION FOR
LIQUID CRYSTAL DISPLAY MODULE
MODEL NO. : NMTG-S12232BFYHSAY

View Direction	<input checked="" type="checkbox"/> 6 O'clock		<input type="checkbox"/> 12 O'clock		
LCD Type	<input type="checkbox"/> FSTN Positive		<input type="checkbox"/> FSTN Negative		
	<input type="checkbox"/> STN Gray	<input checked="" type="checkbox"/> STN Yellow Green	<input type="checkbox"/> STN Blue		
Rear Polarizer	<input type="checkbox"/> Reflective	<input checked="" type="checkbox"/> Transflective	<input type="checkbox"/> Transmissive		
Backlight Type	<input checked="" type="checkbox"/> LED	<input checked="" type="checkbox"/> Internal Power	<input type="checkbox"/> EL	<input checked="" type="checkbox"/> 5V input	
		<input type="checkbox"/> External Power	<input type="checkbox"/> CCFL	<input type="checkbox"/> 24V input	
Backlight Color	<input type="checkbox"/> White	<input type="checkbox"/> Amber	<input type="checkbox"/> Blue Green	<input checked="" type="checkbox"/> Yellow Green	<input type="checkbox"/> Other
Temperature Range	<input type="checkbox"/> Normal		<input checked="" type="checkbox"/> Wide	<input type="checkbox"/> Super Wide	
EL Driver IC	<input type="checkbox"/> Build-in		<input checked="" type="checkbox"/> Not Build-in		
DC-to-DC	<input type="checkbox"/> With		<input checked="" type="checkbox"/> Without		

TO BE VERY CAREFUL !

The LCD driver ICs are made by CMOS process, which are very easy to be damaged by static charge, make sure the user is grounded when handling the LCM.

REV.	DESCRIPTION	DRAWN	CHECK	APP'D	DATE

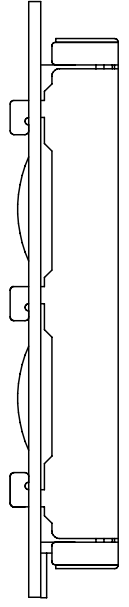
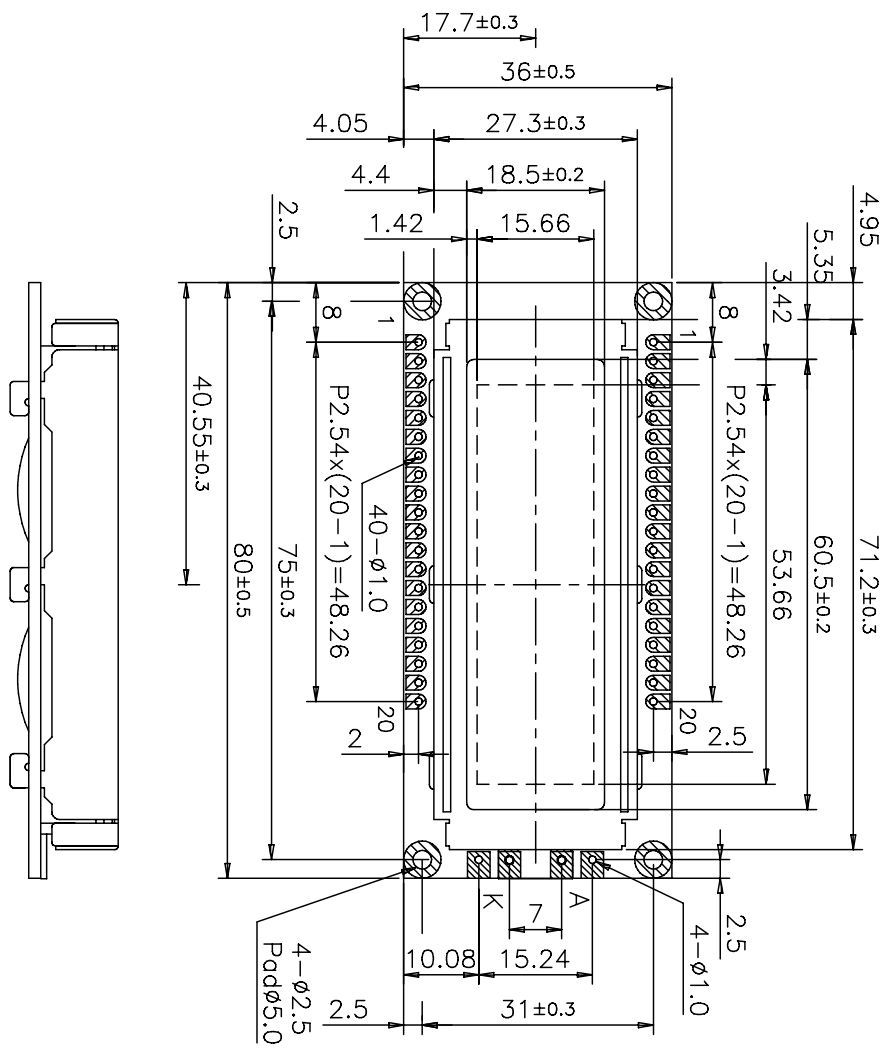
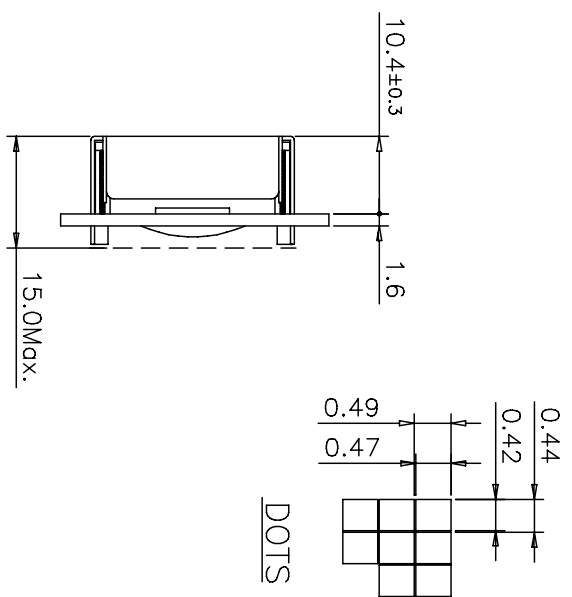

PIN ASSIGNMENT	
1. VSS	5. CS1
2. VDD	6. CS2
3. VEE	7. CL
4. AO	8. /RD(E)
9. /MR(R/W)	13. DB3
10. DBO	14. DB4
11. DB1	15. DB5
12. DB2	16. DB6
17. DB7	18. RES
19. BK1	20. BK12

NO.	M-12232BH	Q'TY	1	DATE:	4-23-99'	MATERIAL	---	FINISH	---
PART NAME		APP'D		UNIT: MM		SCALE: 1/1		PRODUCT: MTG-12232B(H)	
DRAWN		CHECK				UNLESS OTHERWISE SPECIFIED TOLERANCE ON FRACTIONS DECIMALS ANGLES	0.10 0.5°	DWG NO.: G12232B0	
								FILE: DWG\MTG122\G12232B	
								SHEET 1 / 1	Rev: A



GENERAL SPECIFICATION

Item	Content
Display Resolution	122(W)×32(H)
Dimensional Outline(mm)	80.0(W)×36.0(H)×15.0 max(D)
Display mode	Transflective/ Positive Type
Circuit	Common-Driver IC, Segment-driver IC with build-in SRAM
Interface	Data (D0~D7), Ao, RD, WR, RES, CS1, CS2, V _{EE}

ABSOLUTE MAXIMUM RATING

(1) Electrical Absolute Ratings

Item	Symbol	Min.	Max.	Unit	Note
Power Supply for Logic	V _{DD} -V _{SS}	-0.3	8.0	Volt	
Power Supply for LCD	V _{DD} -V _{EE}	-0.3	-16.5	Volt	
Input Voltage	V _I	-0.3	V _{DD}	Volt	
Supply Current for LED backlight	I _{LED}	-	240	mA	

(2) Environmental Absolute Maximum Ratings

Item	Normal Temperature				Wide Temperature			
	Operating		Storage		Operating		Storage	
	Max,	Min.	Max,	Min.	Max,	Min.	Max,	Min.
Ambient Temperature	0°C	+50°C	-20°C	+70°C	-20°C	+70°C	-30°C	+80°C
Humidity(without condensation)	Note 2,4		Note 3,5		Note 4,5		Note 4,6	

Note 2 Ta ≤ 50°C : 80% RH max

Ta > 50°C : Absolute humidity must be lower than the humidity of 85%RH at 50°C

Note 3 Ta at -20°C will be <48hrs at 70°C will be <120hrs when humidity is higher than 70%.

Note 4 Background color changes slightly depending on ambient temperature. This phenomenon is reversible.

Note 5 Ta ≤ 70°C : 75RH max

Ta > 70°C : absolute humidity must be lower than the humidity of 75%RH at 70°C

Note 6 Ta at -30°C will be <48hrs, at 80 °C will be <120hrs when humidity is higher than 70%.

ELECTRICAL CHARACTERISTICS

Item	Symbol	Condition	Min.	Typ	Max.	Unit	note
Power Supply for Logic	$V_{DD}-V_{SS}$	-	2.4	5.0	7.0	Volt	
Input Voltage	V_{IL}	L level	V_{SS}	$0.2 V_{DD}$	-	Volt	
	V_{IH}	H level	$0.8 V_{DD}$	V_{DD}	-	Volt	
LCM Recommend LCD Module Driving Voltage	$V_{DD}-V_{EE}$	$T_a=0^{\circ}C$	5.5	5.68	5.9	Volt	
		$T_a=25^{\circ}C$	5.35	5.54	5.75		
		$T_a=50^{\circ}C$	4.8	5.0	5.2		
Power Supply Current for LCM	I_{DD} (LED B/L OFF)	$V_{DD}=5.0V$ $V_{DD}-V_{EE}=5.54V$ FLM=64Hz $V_{LED}=4.2V$	-	0.6	1.1	mA	
	I_{LED} (LED B/L ON)		-	120	180		
Power supply for EL backlight	V_{EL}			100V/ 400Hz		-	-

OPTICAL CHARACTERISTICS

Item	Symbol	Condition	Min.	Typ	Max.	Unit	note	
Viewing angle range	Φf (12 o'clock)	When $Cr \geq 2$	20	30	-	Degree	9,10	
	Φb (6 o'clock)		40	45	-			
	Φl (9 o'clock)		30	35	-			
	Φr (3 o'clock)		30	35	-			
Rise Time	T_r	$V_{DD}-V_{EE}=5.54V$ $T_a=25^{\circ}C$		86		mS		
Fall Time	T_f			208				
Frame frequency	Frm		-	64	-	Hz		8,10
Contrast	Cr		-	6.53	-			7

MECHANICAL SPECIFICATION

Product No.		NMTG-S12232BFYHSAY
Module Size		80.0(W)×36.0(H)×15.0 max(D)
Dot Size		0.42(W)mm×0.47(H)mm
Dot Pitch		0.44(W)mm×0.49(H)mm
Resolution		122(W)×32(H) Dots Matrix
Duty Ratio		1/32 Duty
LCD Display Mode	STN	<input type="checkbox"/> Gray Mode <input checked="" type="checkbox"/> Yellow Mode <input type="checkbox"/> Blue Mode
	FSTN	<input type="checkbox"/> Black & White(Normally White/Positive Image) <input type="checkbox"/> Black & White(Normally White/Negative Image)
	Rear Polarizer:	<input type="checkbox"/> Reflective <input checked="" type="checkbox"/> Transflective <input type="checkbox"/> Transmissive <input type="checkbox"/> Transflective(High Transmissive)
Viewing Direction		<input checked="" type="checkbox"/> 6 O'clock <input type="checkbox"/> 12 O'clock <input type="checkbox"/> 3 O'clock <input type="checkbox"/> 9 O'clock
Backlight		<input type="checkbox"/> W/O <input type="checkbox"/> CCFL <input type="checkbox"/> EL <input checked="" type="checkbox"/> LED
Controller		Epson SED1520 or compatible
DC/DC Converter		Without
EL Driver		Without

INTERFACE PIN ASSIGNMENT

Pin No.	Pin Out	Description
1	V _{SS}	GND
2	V _{DD}	Logic supply voltage
3	V _{EE}	LCD driver supply voltage
4	Ao	Display Data/Display commands switching input. Ao=0: DB0~DB7 are command input and status output. Ao=1: DB0~DB7 are Display Data input/output.
5	CS1	Chip-select for the left half of the screen. Active LOW
6	CS2	Chip-select for the right half of the screen. Active LOW
7	CL	External Clock Input (typ. 2KHz)
8	/RD(E)	/RD for 80 series, E for 68 series.
9	/WR(R/W)	/WR for 80 series, R/W for 68 series.
10	DB0	3-state I/O Data Bus.
11	DB1	
12	DB2	
13	DB3	
14	DB4	
15	DB5	
16	DB6	
17	DB7	
18	RES	Reset, H for 80 series, L for 68 series.
19	BKL_A	Power Supply for Backlight. 100V/400Hz AC for EL, 5.0V or 120~180mA DC for LED backlight
20	BKL_K	Don't care if no backlight

Jumper Explanation for backlight:

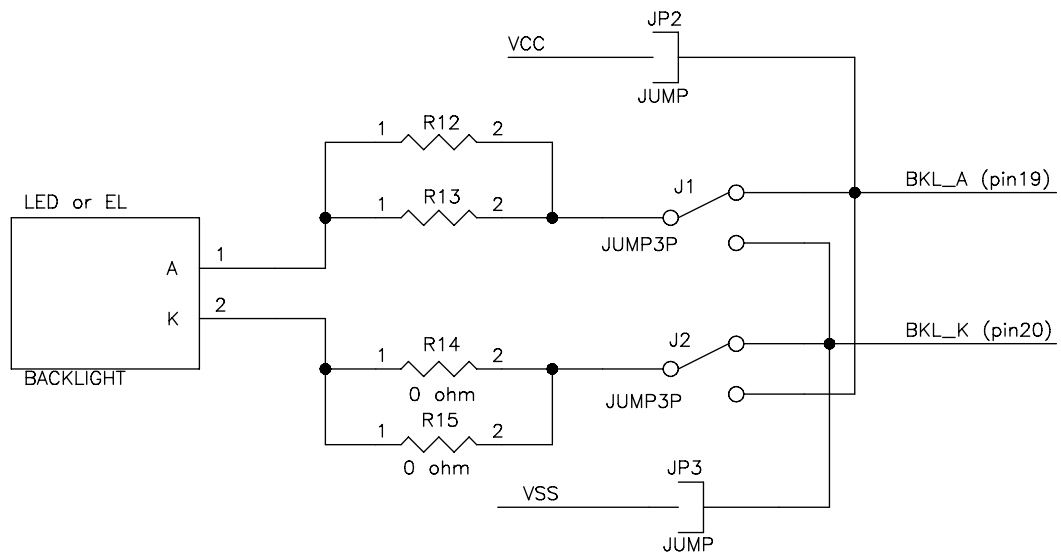

[Note 7] Definition of Operation Voltage (Vop)

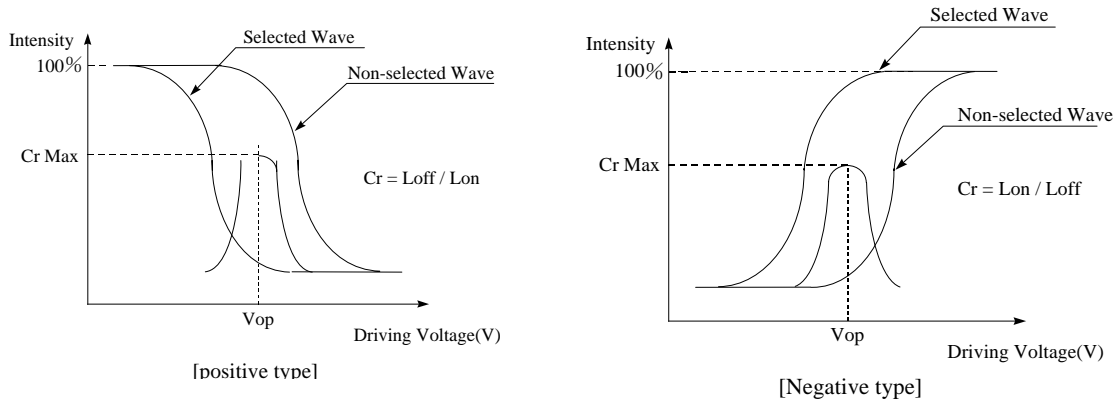

[Note 8] Definition of Response Time (Tr, Tf)

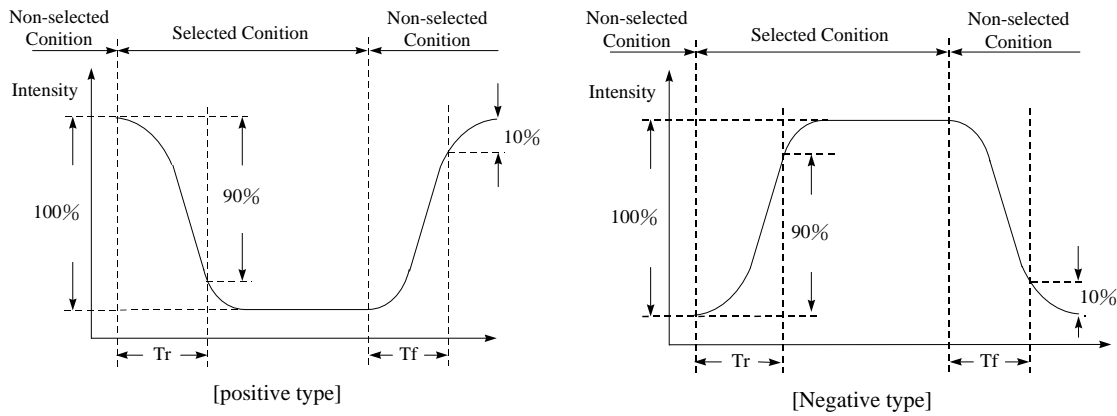

Conditions:

Operating Voltage : Vop

Frame Frequency : 64 Hz

Viewing Angle(θ, φ): $0^\circ, 0^\circ$

Driving Wave form : 1/N duty, 1/a bias

[Note 9] Definition of Viewing Direction

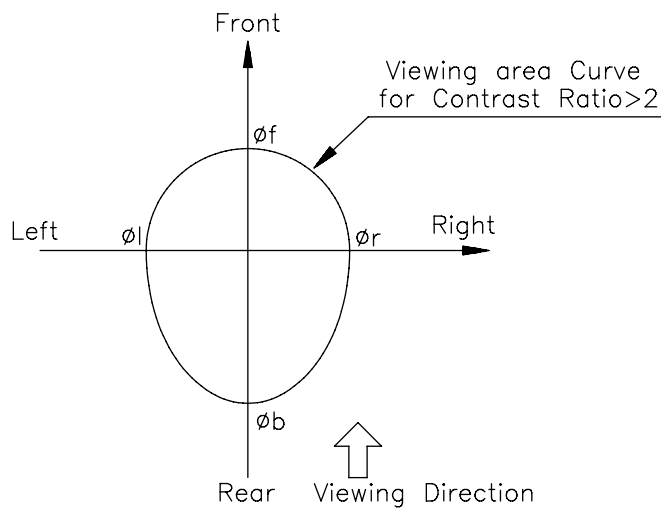

[Note 10] Definition of viewing angle

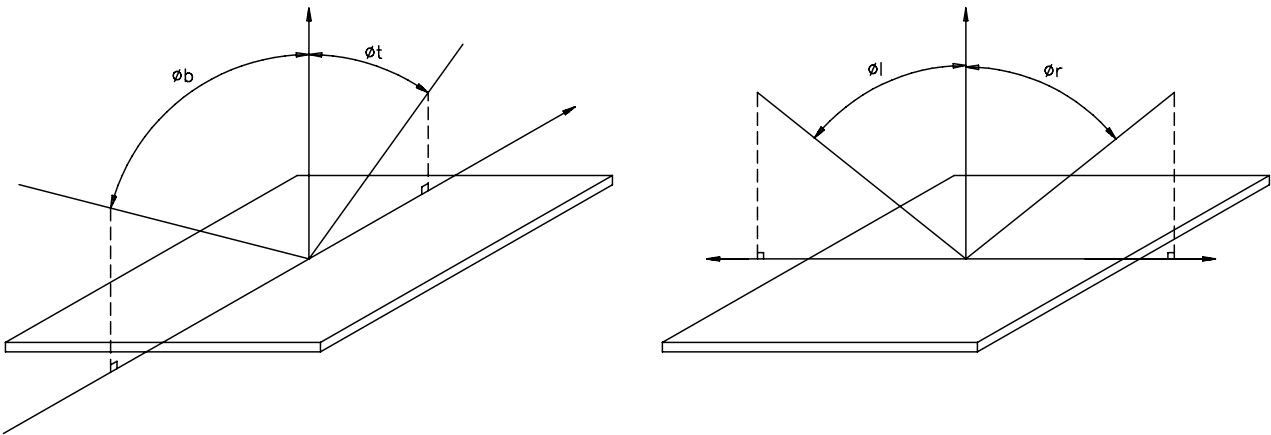

[Note 11] Description of Measuring Equipment

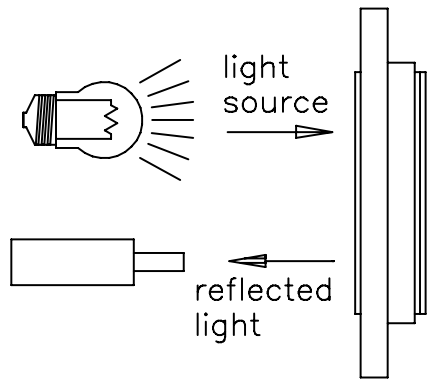

Reflective type

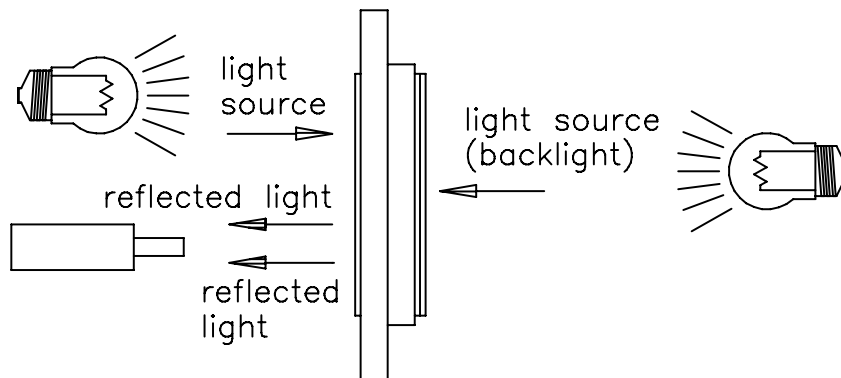

Transflective type

BLOCK DIAGRAM

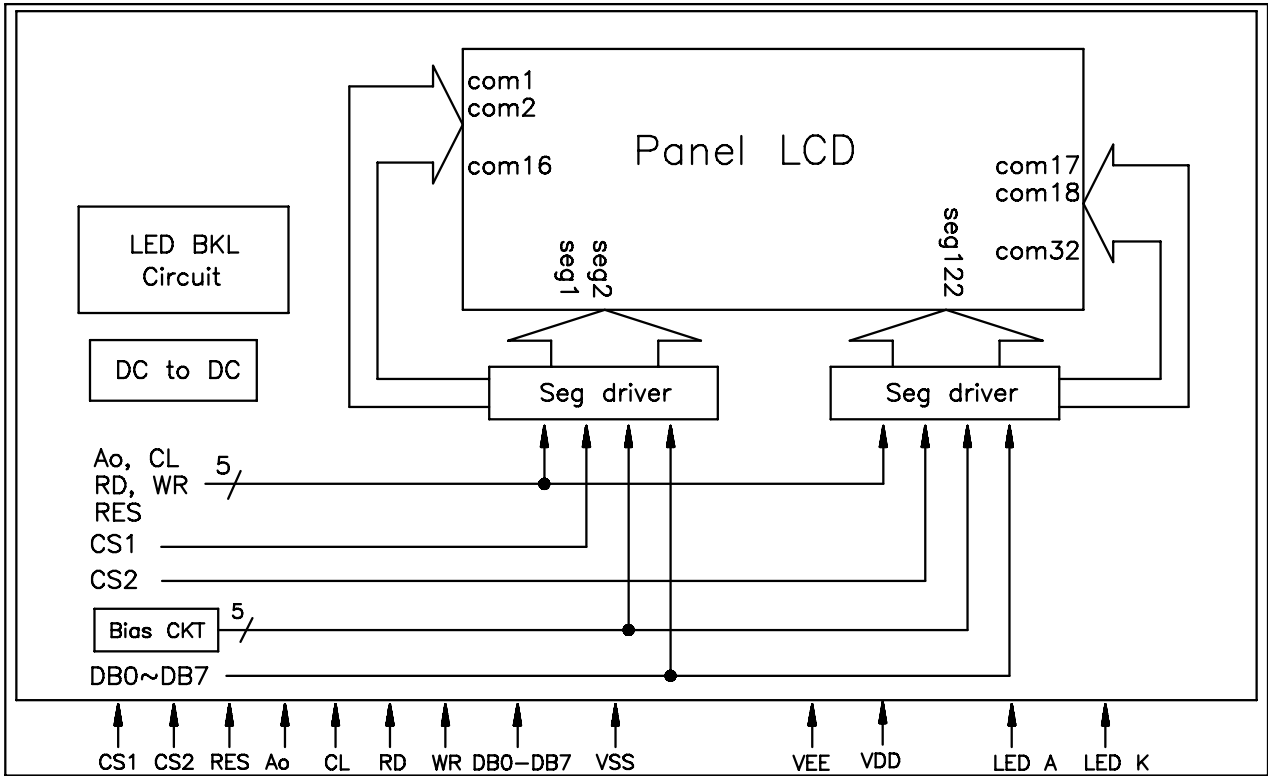

POWER SUPPLY

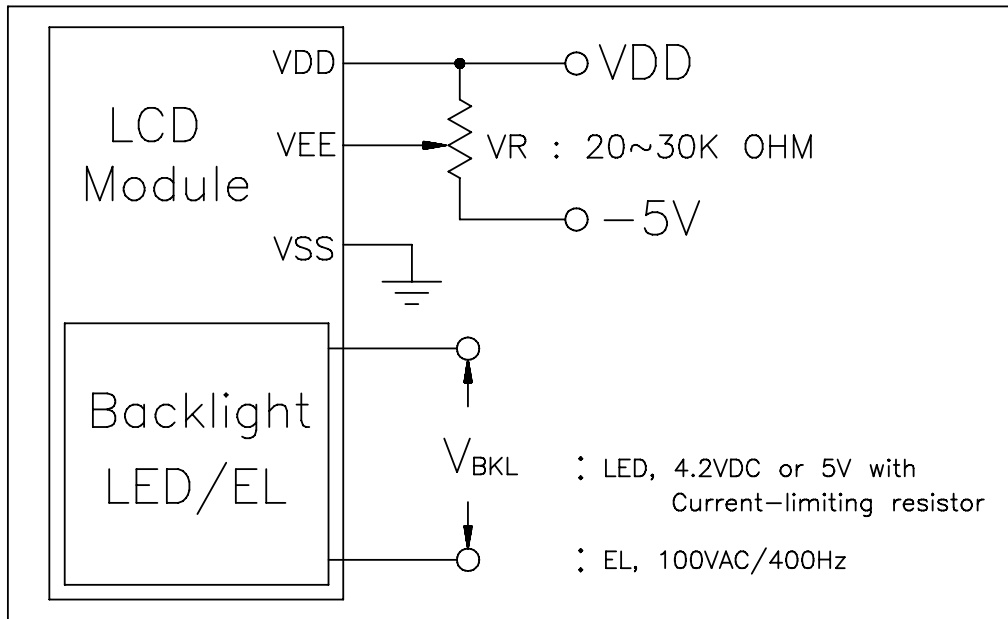

TIMING CHARACTERISTICS

AC Characteristic—MPU Bus Read/Write I (80-Family MPU)

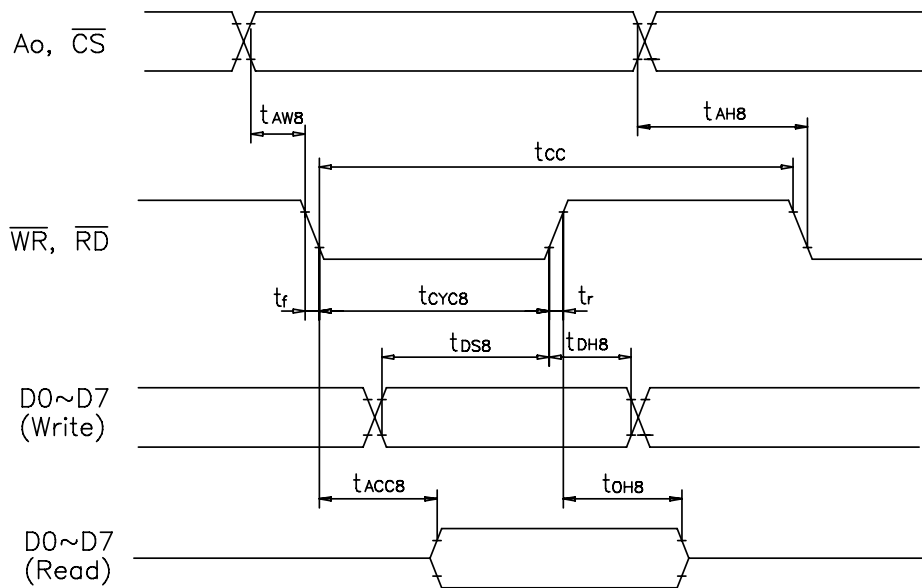

Ta=0~50°C, V_{DD}=5.0V±10%, unless state otherwise

Parameter	Symbol	Condition	Rating		Unit	Signal
			Min.	Max.		
Address hold time	t _{AH8}	-	10	-	ns	Ao, CS
Address setup time	t _{AW8}	-	20	-	ns	
System cycle time	t _{CYC8}	-	1000	-	ns	WR, RD
Control pulse-width	t _{CC}	-	200	-	ns	
Data setup time	t _{DS8}	-	80	-	ns	D0 to D7
Data hold time	t _{DH8}	-	10	-	ns	
RD access time	t _{ACC8}	C _L =100pF	-	90	ns	
Output disable time	t _{CH8}		10	60	ns	
Rise and fall time	t _r , t _f	-	-	15	ns	-

Ta=0~50°C, V_{DD}=2.7 to 4.5V,

Parameter	Symbol	Condition	Rating		Unit	Signal
			Min.	Max.		
Address hold time	t _{AH8}	-	20	-	ns	Ao, CS
Address setup time	t _{AW8}	-	40	-	ns	
System cycle time	t _{CYC8}	-	2000	-	ns	WR, RD
Control pulse-width	t _{CC}	-	400	-	ns	
Data setup time	t _{DS8}	-	160	-	ns	D0 to D7
Data hold time	t _{DH8}	-	20	-	ns	
RD access time	t _{ACC8}	C _L =100pF	-	180	ns	
Output disable time	t _{CH8}		20	120	ns	
Rise and fall time	t _r , t _f	-	-	15	ns	-

AC Characteristic—MPU Bus Read/Write II (68-Family MPU)

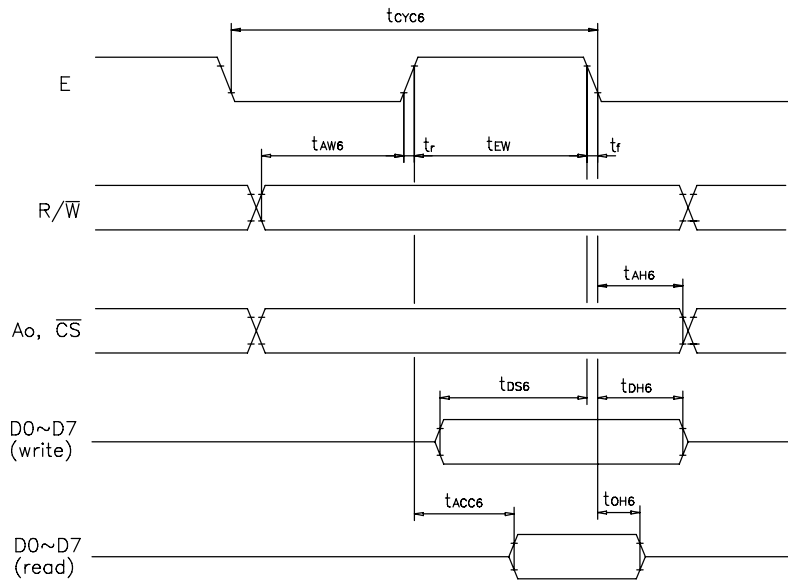

Ta=0~50°C, V_{DD}=5.0V±10%, unless state otherwise

Parameter	Symbol	Condition	Rating		Unit	Signal
			Min.	Max.		
System cycle time	t _{CYC6}		1000	-	ns	Ao, CS, R/W
Address setup time	t _{AW6}		20	-	ns	
Address hold time	t _{AH6}		10	-	ns	
Data setup time	t _{DS6}	C _L =100pF	80	-	ns	D0 to D7
Data hold time	t _{DH6}		10	-	ns	
Output disable time	t _{OH6}		10	60	ns	
Access time	t _{ACC6}		-	90	ns	
Enable pulse-width	Read	t _{EW}	100	-	ns	E
	Write		80	-	ns	
Rise and fall time	t _r , t _f	-	-	15	Ns	-

Ta=0~50°C, V_{DD}=2.7 to 4.5V,

Parameter	Symbol	Condition	Rating		Unit	Signal
			Min.	Max.		
System cycle time	t _{CYC6}		2000	-	ns	Ao, CS, R/W
Address setup time	t _{AW6}		40	-	ns	
Address hold time	t _{AH6}		20	-	ns	
Data setup time	t _{DS6}	C _L =100pF	160	-	ns	D0 to D7
Data hold time	t _{DH6}		20	-	ns	
Output disable time	t _{OH6}		20	120	ns	
Access time	t _{ACC6}		-	180	ns	
Enable pulse-width	Read	t _{EW}	200	-	ns	E
	Write		160	-	ns	
Rise and fall time	t _r , t _f	-	-	15	Ns	-

DISPLAY DATA RAM ADDRESSING

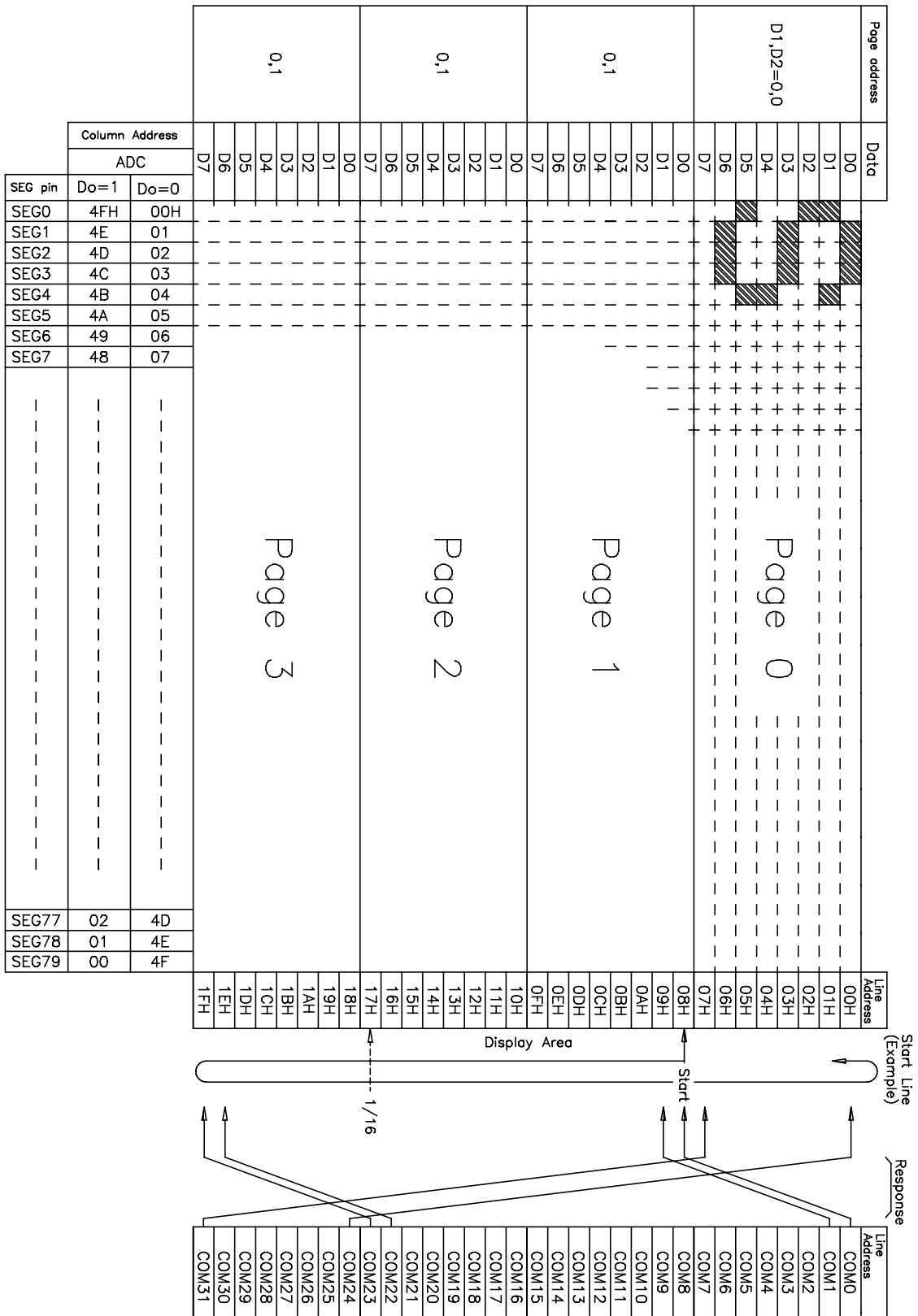

DISPLAY COMMANDS

Instruction	A0	RD	WR	D7	D6	D5	D4	D3	D2	D1	D0	Function
Display ON/OFF	0	1	0	1	0	1	0	1	1	1	1/0	To control the display ON or OFF. The internal status and display RAM data are not affected. 0:OFF, 1:ON
Display start line	0	1	0	1	1	0	Display start address (0~31)					Specifies RAM line corresponding to top line of display.
Set page address	0	1	0	1	0	1	1	1	0	Page (0 to 3)		To set the display RAM page in page address register.
Set column (segment) address	0	1	0	0	Column address (0 to 79)							To set display RAM column address in column address register.
Status Read	0	0	1	Busy	ADC	ON/OFF	Reset	0	0	0	0	Read the following status: Busy 1: Busy 0: Ready ADC 1: CW output 0: CCW output ON/OFF 1: Display OFF 0: Display ON Reset 1: Being reset 0: Normal
Write display data	1	1	0	Write Data							To write data from data bus to display RAM.	
Read display data	1	0	1	Read Data							To read data from display RAM to data bus	
Select ADC	0	1	0	1	0	1	0	0	0	0	0/1	0: CW output, 1: CCW output
Status drive ON/OFF	0	1	0	1	0	1	0	0	1	0	0/1	To select static driving operation 1: Static drive, 0: Normal driving
Select Duty	0	1	0	1	0	1	0	1	0	0	0/1	To select duty cycle 1: 1/32 duty, 0: 1/16 duty
Read-modify-write	0	1	0	1	1	1	0	0	0	0	0	Read-modify-write ON
End	0	1	0	1	1	1	0	1	1	1	0	Read-modify-write OFF
Reset	0	1	0	1	1	1	0	0	0	1	0	To reset by software

COMMAND DESCRIPTION

Display ON/OFF

Ao	RD	WR	D7	D6	D5	D4	D3	D2	D1	D0	
0	1	0	1	0	1	0	1	1	1	D	AEH, AFH

This command turns the display ON or OFF.

D=1 : Display ON

D=0 : Display OFF

Display Start Line

This command specifies the line address shown in page 13 and indicates the display line that corresponding to COM 0. The display area begins at the specified line address and continues in the line address increment direction. This area having the number of line of specified display duty is displayed. If the line address is changed dynamically by this command, the vertical smooth scrolling and paging can be used.

Ao	RD	WR	D7	D6	D5	D4	D3	D2	D1	D0	
0	1	0	1	1	0	A4	A3	A2	A1	A0	C0H to DFH

This command loads the display start line register.

A4	A3	A2	A1	A0	Line Address
0	0	0	0	0	0
0	0	0	0	1	1
		⋮			⋮
1	1	1	1	1	31

See the figure in page 13.

Set Page address

This command specifies the page address that corresponds to the low address of the display data RAM when it is accessed by the MPU. Any bit of the display data RAM can be accessed when its page address and column address are specified. The display status is not changed even when the page address is changed.

Ao	RD	WR	D7	D6	D5	D4	D3	D2	D1	D0	
0	1	0	11	0	1	1	1	0	A1	A0	B8H to BBH

This command loads the page address register.

A1	A0	Page
0	0	0
0	1	1
1	0	2
1	1	3

See the figure in page 13.

Set Column Address

This command specifies a column address of the display data RAM. When the display data RAM is accessed by the MPU continuously, the column address is increased by 1 every time. Therefore the MPU can access to data continuously. The column address stops to be incremented at address 80, and the page address is not changed continuously.

Ao	RD	WR	D7	D6	D5	D4	D3	D2	D1	D0
0	1	0	0	A6	A5	A4	A3	A2	A1	A0

00H to 4FH

This command loads the column address register.

A6	A5	A4	A3	A2	A1	A0	Line Address
0	0	0	0	0	0	0	0
0	0	0	0	0	0	1	1
			⋮				⋮
1	1	1	1	1	1	1	79

Read Status

Ao	RD	WR	D7	D6	D5	D4	D3	D2	D1	D0
0	0	1	BUSY	ADC	ON/OFF	RESET	0	0	0	0

00H to 4FH

Reading the command I/O register (Ao=0) yields system status information.

- The busy bit indicates whether the driver will accept a command or not.
 - Busy=1: The driver is currently executing a command or is resetting. No new command will be accepted.
 - Busy=0: The driver will accept a new command.
- The ADC bit indicates the way column addresses are assigned to a segment drivers
 - ADC=1: Normal. Column address n → segment address n.
 - ADC=0: Inverted. Column address 79-u → segment driver u.
- The ON/OFF bit indicates the current status of the display.
 - ON/OFF=1: Display OFF.
 - ON/OFF=0: Display ON.
- The RESET bit indicates whether the driver is executing a hardware or a software reset or it is in a normal operating mode.
 - RESET=1: Currently executing the reset command.
 - RESET=0: Normal operating.

Write Display Data

Ao	RD	WR	D7	D6	D5	D4	D3	D2	D1	D0
1	1	0	Write Data							

To write an 8-bit data into the display RAM, at a location specified by the contents of the column address and page address register by one.

Read Display Data

Ao	RD	WR	D7	D6	D5	D4	D3	D2	D1	D0
1	0	1	Read Data							

To read an 8-bit data from the data I/O latch, updates the contents of the I/O latch with display data from the display data RAM location specified by the contents of the column address and page address registers and then increments the column address register.

After loading a new address into the column address register one dummy read is required before valid data is obtained.

Select ADC

Ao	RD	WR	D7	D6	D5	D4	D3	D2	D1	D0
0	1	0	1	0	1	0	0	0	0	D

A0H, A1H

This command selects the relationship between display data RAM column address and segment driver.

D=0: SEG0 ← column address 00H, ...(normal)

This command is provided to reduce restrictions on the placement of the driver ICs and routing of tracing during printed circuit board layout. In this LCD module the D should be cleared to 0.

Static Driver ON/OFF

Ao	RD	WR	D7	D6	D5	D4	D3	D2	D1	D0
0	1	0	1	0	1	0	0	1	0	D

A4H, A5H

To force the display on and all common outputs to be selected.

D=1: Static driver ON.

D=0: Static driver OFF.

Select Duty

Ao	RD	WR	D7	D6	D5	D4	D3	D2	D1	D0
0	1	0	1	0	1	0	1	0	0	D

A8H, A9H

To set the D-bit to 1 because the LCD module is 1/32 duty.

End

Ao	RD	WR	D7	D6	D5	D4	D3	D2	D1	D0
0	1	0	1	1	1	0	1	1	1	0

EEH

This command cancels the **Read-Modify-Write** mode and restores the contents of the column address register to their value prior to the receipt of the **Read-Modify-Write** command.

Reset

Ao	RD	WR	D7	D6	D5	D4	D3	D2	D1	D0
0	1	0	1	1	1	0	0	0	1	0

E2H

This command clears:

The display start line register and to set page address register to 3 page.

It does not affect the contents of the display data RAM. When the power supply is turned on, the user must sent a Reset signal into the RES pin. The Reset command cannot be used instead of this Reset signal.

Read-Modify-Write

A ₀	RD	WR	D7	D6	D5	D4	D3	D2	D1	D0	
0	1	0	1	1	1	0	0	0	0	0	E0H

This command defeats column address register auto-increment after reading data. The current contents of the column address register are saved. This mode remains active until an **END** command is received.

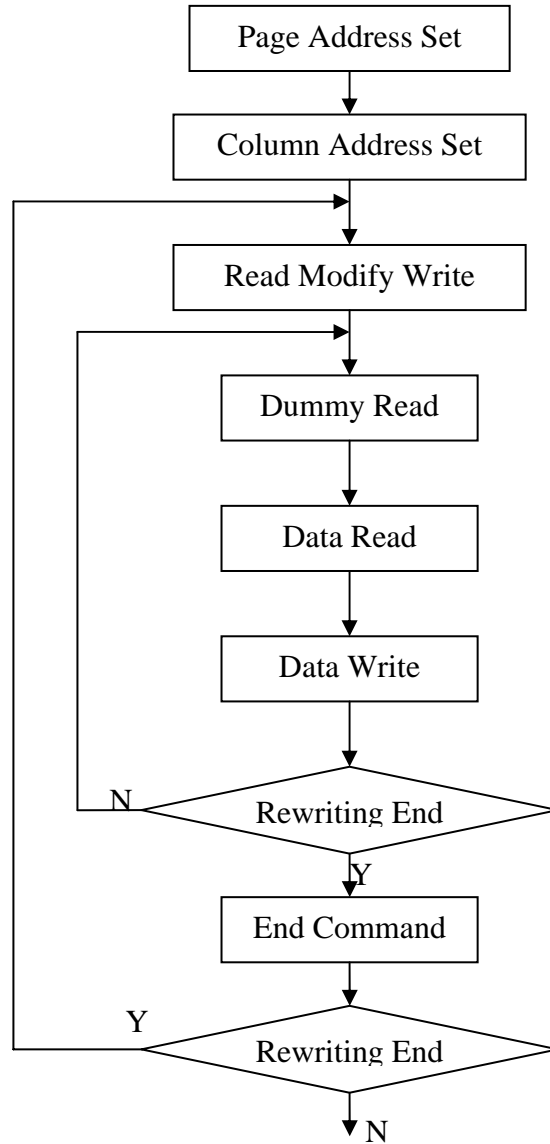

INITIALIZATION PROCEDURE

Detects a rising edge or falling edge of an RES input and initializes the MPU during power-on.
Initialization status:

1. Display is OFF
2. Display start line register is set to line 1
3. Static drive is turn off
4. Column address counter is set to address 0.
5. Page address register is set to page 3.
6. 1/32 duty is selected.
7. Forward ADC is selected(ADC command D0 is 1 and ADC status flag is 1)
8. Read-modify-write is OFF.

The input signal level at RES pin is sensed, and the MPU interface mode is selected as shown in Table below. For the 80-series MPU, the RES pin is passed through the inverter and the active high reset signal must be entered. For the 68-series MPU, the active low reset signal must be entered.

RES signal input level	MPU type	Ao	E	R/W	CS	D0~D7
Active LOW	68-series	↑	↑	↑	↑	↑
Active HIGH	80-series	↑	RD	WR	↑	↑

RELIABILITY TEST

No	Item	Conditions		Note
1	High Temp. Operation	70°C	240 HR	
2	High Temp. Storage	80°C	240 HR	
3	Low Temp. Operation	-20°C	240 HR	
4	Low Temp. Storage	-30°C	240 HR	
5	High Temp./Humid Storage	40°C 90%RH	240 HR	
6	Thermal Shock	0°C ,30min +40°C ,30min	10 cycles	
7	Vibration Test (IEC-68-2-6)	Frequency : 10~55 Hz Duration : 20 times, 6 min/time Amplitude : 0.75 mm	-	
8	Shock (IEC 68-2-27)	Duration : 11 mS Acceleration : 100g	-	X, Y, Z direction

APPEARANCE CHECK

CONDIITON OF APPEARANCE CHECK:

- (1) Specimen shall be checked by eyes in distance of 30cm under 40w-fluorescence lamp.
- (2) Checking direction shall be in 45 degree from perpendicular line op specimen surface.

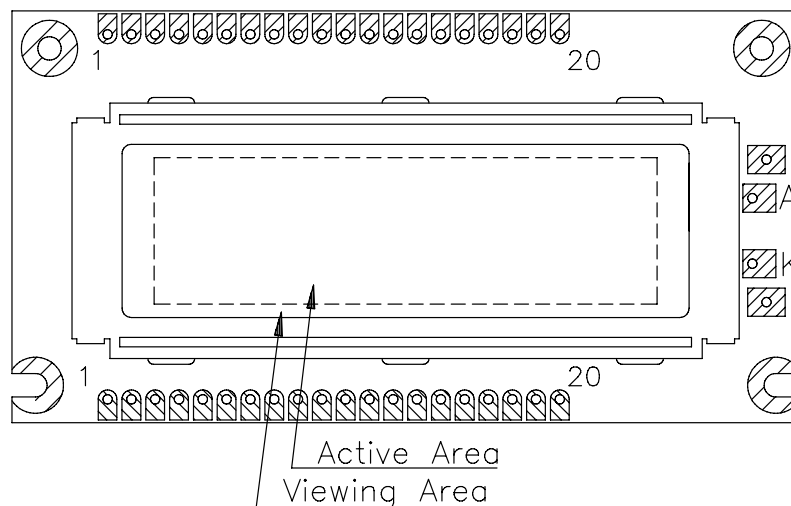

HANDLING PRECAUTIONS

- (1) Treat polarizer very carefully since it is easy to be damaged.
- (2) When cleaning the display surface, use soft cloth (e.g. gauss) with a solvent (recommended below) and wipe lightly.

- ◆ ethyl alcohol
- ◆ iso-procolol

Do not wipe the display surface with dry or hard materials that will damage the polarizer surface.

Do not use the following solvents:

- ◆ water
- ◆ ketone
- ◆ aromatics

- (3) Direct current causes electro-chemical reaction with remarkable degradation of the display quality. Give careful consideration to prevent direct current at ON/OFF timing and during operation.
- (4) Avoid strong shock and drop from the height.
- (5) To prevent LCD panels from degradation, do not operate or store them exposed directly to sunshine or high temperature/humidity.
- (6) Give careful consideration to avoid electrical static discharge with causes uneven contrast.
- (7) Even a small condensation on the contact pads (terminals) causes electro-chemical reaction which makes missing row and column. Give careful attention to avoid condensation. When assembling with zebra connector, clean the surface of the pads with alcohol and keep the air very clean.

LCD PRODUCT QUALITY STANDARD

DISPLAY APPEARANCE

No	Item	Criteria
1	inclusions (black spot, white spot, dust)	<p>(1)round type diameter mm(a*) no of defect*</p> <p>$a \leq 0.20$ neglect</p> <p>$0.20 < a \leq 0.35$ 5max</p> <p>$0.35 < a$ none</p> <p>(2)linear type length mm(l) width mm(W) no. of defect</p> <p>na $W \leq 0.03$ neglect</p> <p>$1 \leq 3$ $0.03 < W \leq 0.08$ 6</p> <p>$3 < l$ $0.08 < W$ none</p>
2	scratch	<p>1. scratch on protective film is permitted. 2. scratch on polarizer shall be as follow:</p> <p>(1)round type diameter mm(a*) no of defect</p> <p>$a \leq 0.15$ neglect</p> <p>$0.15 < a \leq 0.20$ 2 max</p> <p>$0.20 < a$ none</p> <p>(2)linear type be judged by 1.-(2) linear type</p>
3	dent	diameter < 1.5mm
4	bubble	not exceeding 0.5mm average diameter is acceptable between glass and polarizing film
5	pin hole	$(a+b)/2 \leq 0.15\text{mm}$ maximum number: ignored $0.15 < (a+b)/2 \leq 0.20\text{mm}$ maximum number: 10
6	dot defect	$(a+b)/2 \leq 0.20\text{mm}$ maximum number: ignored $0.20 < (a+b)/2 \leq 0.30\text{mm}$ maximum number: 5 x=width
7	contrast irregularity(spot)	diameter spec no of defect $a \leq 0.50\text{mm}$ neglect $0.50 < a \leq 0.75$ 5 $0.75 < a \leq 1.00$ 3 $1.00 < a$ none
8	dot width	design width $\pm 15\%$
9	color tone and uniformity	obvious uneven color is not permitted

REVISION HISTORY

Revision Content	Page	Date
The LCD module is compliant with RoHS	3-23	2006/11/8



**Стандарт
Электрон
Связь**

Мы молодая и активно развивающаяся компания в области поставок электронных компонентов. Мы поставляем электронные компоненты отечественного и импортного производства напрямую от производителей и с крупнейших складов мира.

Благодаря сотрудничеству с мировыми поставщиками мы осуществляем комплексные и плановые поставки широчайшего спектра электронных компонентов.

Собственная эффективная логистика и склад в обеспечивает надежную поставку продукции в точно указанные сроки по всей России.

Мы осуществляем техническую поддержку нашим клиентам и предпродажную проверку качества продукции. На все поставляемые продукты мы предоставляем гарантию .

Осуществляем поставки продукции под контролем ВП МО РФ на предприятия военно-промышленного комплекса России , а также работаем в рамках 275 ФЗ с открытием отдельных счетов в уполномоченном банке. Система менеджмента качества компании соответствует требованиям ГОСТ ISO 9001.

Минимальные сроки поставки, гибкие цены, неограниченный ассортимент и индивидуальный подход к клиентам являются основой для выстраивания долгосрочного и эффективного сотрудничества с предприятиями радиоэлектронной промышленности, предприятиями ВПК и научно-исследовательскими институтами России.

С нами вы становитесь еще успешнее!

Наши контакты:

Телефон: +7 812 627 14 35

Электронная почта: sales@st-electron.ru

Адрес: 198099, Санкт-Петербург,
Промышленная ул, дом № 19, литера Н,
помещение 100-Н Офис 331