

### Description

The 9DBL0641 / 9DBL0651 devices are 3.3V members of IDT's Full-Featured PCIe family. The 9DBL06 supports PCIe Gen1-4 Common Clocked (CC) and PCIe Separate Reference Independent Spread (SRIS) systems. It offers a choice of integrated output terminations providing direct connection to 85Ω or 100Ω transmission lines. The 9DBL06P1 can be factory programmed with a user-defined power up default SMBus configuration.

### Recommended Application

PCIe Gen1-4 clock distribution for Riser Cards, Storage, Networking, JBOD, Communications, Access Points

### Output Features

- 6 – 1-200 MHz Low-Power (LP) HCSL DIF pairs
- 9DBL0641 default Z<sub>OUT</sub> = 100Ω
- 9DBL0651 default Z<sub>OUT</sub> = 85Ω
- 9DBL06P1 factory programmable defaults

### Key Specifications

- PCIe Gen1-2-3-4 CC compliant in ZDB mode
- PCIe Gen2 SRIS compliant in ZDB mode
- Supports PCIe Gen2-3 SRIS in fan-out mode
- DIF cycle-to-cycle jitter <50ps
- DIF output-to-output skew < 50ps
- Bypass mode additive phase jitter is 0 ps typical rms for PCIe
- Bypass mode additive phase jitter 160fs rms typ. @ 156.25M (1.5M to 10M)

### Features/Benefits

- Direct connection to 100Ω (xx41) or 85Ω (xx51) transmission lines; saves 24 resistors compared to standard PCIe devices
- 149mW typical power consumption (PLL mode@3.3V); eliminates thermal concerns
- VDDIO allows 30% power savings at optional 1.05V; maximum power savings
- SMBus-selectable features allows optimization to customer requirements:
  - control input polarity
  - control input pull up/downs
  - slew rate for each output
  - differential output amplitude
  - output impedance for each output
  - 50, 100, 125MHz operating frequency
- Customer defined SMBus power up default can be programmed into P1 device; allows exact optimization to customer requirements
- OE# pins; support DIF power management
- HCSL-compatible differential input; can be driven by common clock sources
- Spread Spectrum tolerant; allows reduction of EMI
- Pin/SMBus selectable PLL bandwidth and PLL Bypass; minimize phase jitter for each application
- Outputs blocked until PLL is locked; clean system start-up
- Device contains default configuration; SMBus interface not required for device operation
- Three selectable SMBus addresses; multiple devices can easily share an SMBus segment
- Space saving 40-pin 5x5mm VFQFPN; minimal board space

### Block Diagram

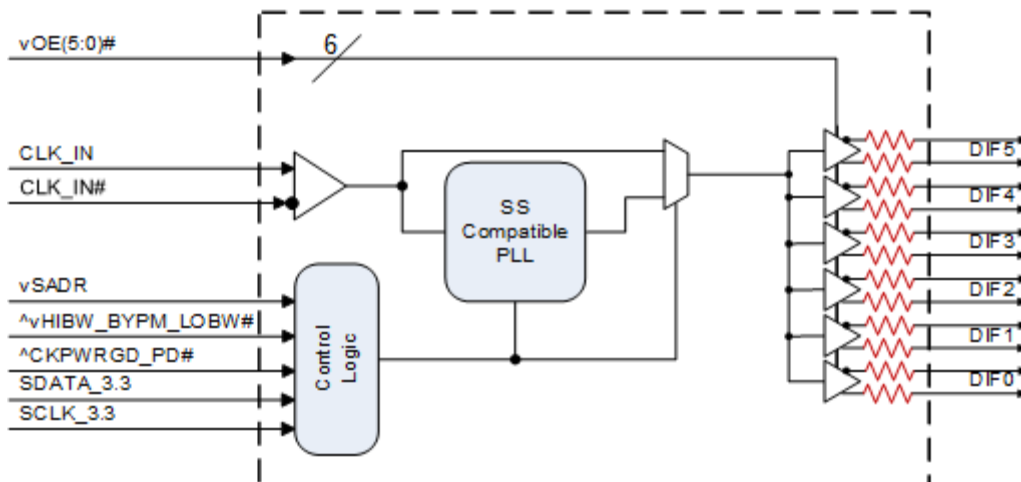

**Note:** Default resistors are internal on xx41/xx51 devices. P1 devices have programmable default impedances on an output-by-output basis.

## Pin Configuration

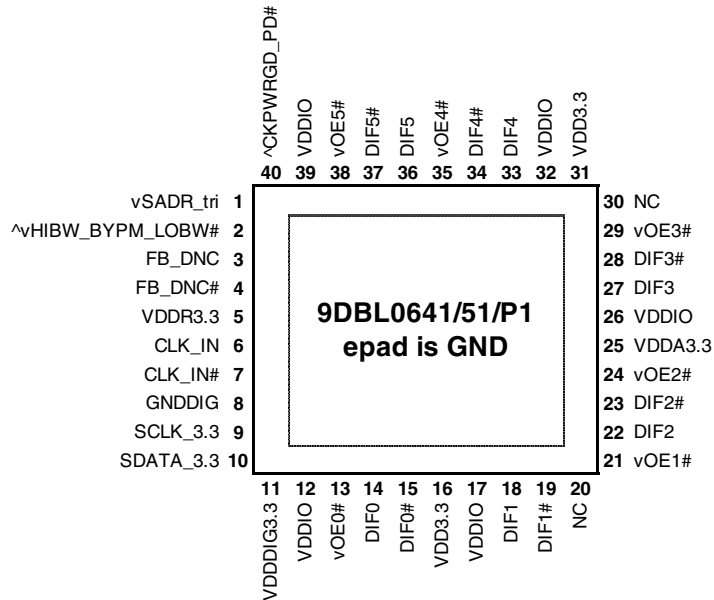

40-VFQFPN, 5mm x 5mm 0.4mm pin pitch

^ prefix indicates internal 120KOhm pull up resistor

^v prefix indicates internal 120KOhm pull up AND pull down resistor (biased to VDD/2)

v prefix indicates internal 120KOhm pull down resistor

## SMBus Address Selection Table

	SADR	Address	+ Read/Write bit
State of SADR on first application of CKPWRGD_PD#	0	1101011	x
	M	1101100	x
	1	1101101	x

Note: If not using CKPWRGD (CKPWRGD tied to VDD3.3), all 3.3V VDD need to transition from 2.1V to 3.135V in <300usec.

## Power Management Table

CKPWRGD_PD#	CLK_IN	SMBus OEx bit	OEx# Pin	DIFx		PLL
				True O/P	Comp. O/P	
0	X	X	X	Low <sup>1</sup>	Low <sup>1</sup>	Off
1	Running	0	X	Low <sup>1</sup>	Low <sup>1</sup>	On <sup>2</sup>
1	Running	1	0	Running	Running	On <sup>2</sup>
1	Running	1	1	Low <sup>1</sup>	Low <sup>1</sup>	On <sup>2</sup>

1. The output state is set by B11[1:0] (Low/Low default)

2. If Bypass mode is selected, the PLL will be off, and outputs will be running.

## Power Connections

Pin Number			Description
VDD	VDDIO	GND	
5		41	Input receiver analog
11		8	Digital Power
16, 31	12, 17, 26, 32, 39	41	DIF outputs, Logic
25		41	PLL Analog

## PLL Operating Mode

HiBW_Bypm_LoBW#	MODE	Byte1 [7:6] Readback	Byte1 [4:3] Control
0	PLL Lo BW	00	00
M	Bypass	01	01
1	PLL Hi BW	11	11

## Pin Descriptions

PIN #	PIN NAME	PIN TYPE	DESCRIPTION
1	vSADR_tri	LATCHED IN	Tri-level latch to select SMBus Address. See SMBus Address Selection Table.
2	^vHIBW_BYPM_LOBW#	LATCHED IN	Trilevel input to select High BW, Bypass or Low BW mode. This pin is biased to VDD/2 (Bypass mode) with internal pull up/pull down resistors. See PLL Operating Mode Table for Details.
3	FB_DNC	DNC	True clock of differential feedback. The feedback output and feedback input are connected internally on this pin. Do not connect anything to this pin.
4	FB_DNC#	DNC	Complement clock of differential feedback. The feedback output and feedback input are connected internally on this pin. Do not connect anything to this pin.
5	VDDR3.3	PWR	3.3V power for differential input clock (receiver). This VDD should be treated as an Analog power rail and filtered appropriately.
6	CLK_IN	IN	True Input for differential reference clock.
7	CLK_IN#	IN	Complementary Input for differential reference clock.
8	GNDDIG	GND	Ground pin for digital circuitry
9	SCLK_3.3	IN	Clock pin of SMBus circuitry, 3.3V tolerant.
10	SDATA_3.3	I/O	Data pin for SMBus circuitry, 3.3V tolerant.
11	VDDDIG3.3	PWR	3.3V digital power (dirty power)
12	VDDIO	PWR	Power supply for differential outputs
13	vOE0#	IN	Active low input for enabling DIF pair 0. This pin has an internal pull-down. 1 =disable outputs, 0 = enable outputs
14	DIF0	OUT	Differential true clock output
15	DIF0#	OUT	Differential Complementary clock output
16	VDD3.3	PWR	Power supply, nominal 3.3V
17	VDDIO	PWR	Power supply for differential outputs
18	DIF1	OUT	Differential true clock output
19	DIF1#	OUT	Differential Complementary clock output
20	NC	N/A	No Connection.
21	vOE1#	IN	Active low input for enabling DIF pair 1. This pin has an internal pull-down. 1 =disable outputs, 0 = enable outputs
22	DIF2	OUT	Differential true clock output
23	DIF2#	OUT	Differential Complementary clock output
24	vOE2#	IN	Active low input for enabling DIF pair 2. This pin has an internal pull-down. 1 =disable outputs, 0 = enable outputs
25	VDDA3.3	PWR	3.3V power for the PLL core.
26	VDDIO	PWR	Power supply for differential outputs
27	DIF3	OUT	Differential true clock output
28	DIF3#	OUT	Differential Complementary clock output
29	vOE3#	IN	Active low input for enabling DIF pair 3. This pin has an internal pull-down. 1 =disable outputs, 0 = enable outputs
30	NC	N/A	No Connection.
31	VDD3.3	PWR	Power supply, nominal 3.3V
32	VDDIO	PWR	Power supply for differential outputs
33	DIF4	OUT	Differential true clock output
34	DIF4#	OUT	Differential Complementary clock output
35	vOE4#	IN	Active low input for enabling DIF pair 4. This pin has an internal pull-down. 1 =disable outputs, 0 = enable outputs
36	DIF5	OUT	Differential true clock output
37	DIF5#	OUT	Differential Complementary clock output
38	vOE5#	IN	Active low input for enabling DIF pair 5. This pin has an internal pull-down. 1 =disable outputs, 0 = enable outputs
39	VDDIO	PWR	Power supply for differential outputs
40	^CKPWRGD_PD#	IN	Input notifies device to sample latched inputs and start up on first high assertion. Low enters Power Down Mode, subsequent high assertions exit Power Down Mode. This pin has internal pull-up resistor.
41	ePAD	GND	Connect paddle to ground.

## Test Loads

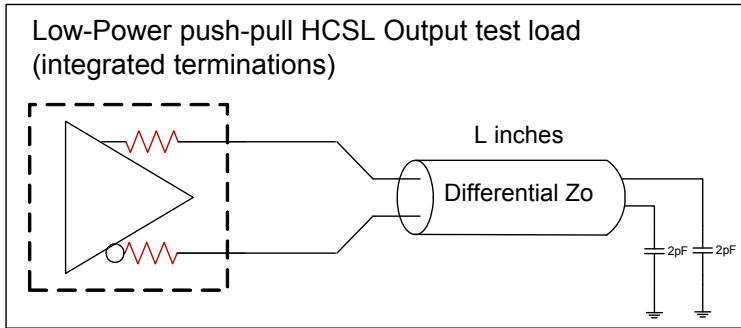

L = 5 inches

## Terminations

Device	$Z_o$ ( $\Omega$ )	$R_s$ ( $\Omega$ )
9DBL0641	100	None needed
9DBL0651	100	7.5
9DBL06P1	100	Prog.
9DBL0641	85	N/A
9DBL0651	85	None needed
9DBL06P1	85	Prog.

## Alternate Terminations

The 9DBL0641 / 9DBL0651 can easily drive LVPECL, LVDS, and CML logic. See [“AN-891 Driving LVPECL, LVDS, and CML Logic with IDT's "Universal" Low-Power HCSL Outputs”](#) for details.

## Absolute Maximum Ratings

Stresses above the ratings listed below can cause permanent damage to the 9DBL0641 / 9DBL0651. These ratings, which are standard values for IDT commercially rated parts, are stress ratings only. Functional operation of the device at these or any other conditions above those indicated in the operational sections of the specifications is not implied. Exposure to absolute maximum rating conditions for extended periods can affect product reliability. Electrical parameters are guaranteed only over the recommended operating temperature range.

PARAMETER	SYMBOL	CONDITIONS	MIN	TYP	MAX	UNITS	NOTES
Supply Voltage	VDDx				4.6	V	1,2
Input Voltage	V <sub>IN</sub>		-0.5		V <sub>DD</sub> +0.5	V	1,3
Input High Voltage, SMBus	V <sub>IHSMB</sub>	SMBus clock and data pins			3.9	V	1
Storage Temperature	T <sub>s</sub>		-65		150	°C	1
Junction Temperature	T <sub>j</sub>				125	°C	1
Input ESD protection	ESD prot	Human Body Model	2500			V	1

<sup>1</sup>Guaranteed by design and characterization, not 100% tested in production.

<sup>2</sup>Operation under these conditions is neither implied nor guaranteed.

<sup>3</sup>Not to exceed 4.6V.

## Electrical Characteristics–Clock Input Parameters

TA = T<sub>AMB</sub>; Supply Voltages per normal operation conditions, See Test Loads for Loading Conditions

PARAMETER	SYMBOL	CONDITIONS	MIN	TYP	MAX	UNITS	NOTES
Input Crossover Voltage - DIF_IN	V <sub>CROSS</sub>	Cross Over Voltage	150		900	mV	1
Input Swing - DIF_IN	V <sub>SWING</sub>	Differential value	300			mV	1
Input Slew Rate - DIF_IN	dv/dt	Measured differentially	0.4		8	V/ns	1,2
Input Leakage Current	I <sub>IN</sub>	V <sub>IN</sub> = V <sub>DD</sub> , V <sub>IN</sub> = GND	-5		5	uA	
Input Duty Cycle	d <sub>tin</sub>	Measurement from differential waveform	45		55	%	1
Input Jitter - Cycle to Cycle	J <sub>DIFIn</sub>	Differential Measurement	0		125	ps	1

<sup>1</sup>Guaranteed by design and characterization, not 100% tested in production.

<sup>2</sup>Slew rate measured through +/-75mV window centered around differential zero

## Electrical Characteristics–SMBus Parameters

TA = T<sub>AMB</sub>; Supply Voltages per normal operation conditions, See Test Loads for Loading Conditions

PARAMETER	SYMBOL	CONDITIONS	MIN	TYP	MAX	UNITS	NOTES
SMBus Input Low Voltage	V <sub>ILSMB</sub>	V <sub>DD</sub> SMB = 3.3V			0.8	V	
SMBus Input High Voltage	V <sub>IHSMB</sub>	V <sub>DD</sub> SMB = 3.3V	2.1		3.6	V	
SMBus Output Low Voltage	V <sub>OLSMB</sub>	@ I <sub>PULLUP</sub>			0.4	V	
SMBus Sink Current	I <sub>PULLUP</sub>	@ V <sub>OL</sub>	4			mA	
Nominal Bus Voltage	V <sub>DD</sub> SMB		2.7		3.6	V	
SCLK/SDATA Rise Time	t <sub>RSMB</sub>	(Max VIL - 0.15) to (Min VIH + 0.15)			1000	ns	1
SCLK/SDATA Fall Time	t <sub>FSMB</sub>	(Min VIH + 0.15) to (Max VIL - 0.15)			300	ns	1
SMBus Operating Frequency	f <sub>SMB</sub>	SMBus operating frequency			500	kHz	2,3

<sup>1</sup>Guaranteed by design and characterization, not 100% tested in production.

<sup>2</sup>The device must be powered up for the SMBus to function.

<sup>3</sup>The differential input clock must be running for the SMBus to be active

## Electrical Characteristics–Input/Supply/Common Parameters–Normal Operating Conditions

TA = T<sub>AMB</sub>, Supply Voltages per normal operation conditions, See Test Loads for Loading Conditions

PARAMETER	SYMBOL	CONDITIONS	MIN	TYP	MAX	UNITS	NOTES
Supply Voltage	VDDx	Supply voltage for core and analog	3.135	3.3	3.465	V	
Output Supply Voltage	VDDIO	Supply voltage for Low Power HCSL Outputs	0.95	1.05-3.3	3.465	V	
Ambient Operating Temperature	T <sub>AMB</sub>	Industrial range	-40	25	85	°C	
Input High Voltage	V <sub>IH</sub>	Single-ended inputs, except SMBus	0.75 V <sub>DDx</sub>		V <sub>DDx</sub> + 0.3	V	
Input Low Voltage	V <sub>IL</sub>		-0.3		0.25 V <sub>DDx</sub>	V	
Input High Voltage	V <sub>IHtri</sub>	Single-ended tri-level inputs ('_tri' suffix)	0.75 V <sub>DDx</sub>		V <sub>DD</sub> + 0.3	V	
Input Mid Voltage	V <sub>IMtri</sub>		0.4 V <sub>DDx</sub>	0.5 V <sub>DDx</sub>	0.6 V <sub>DDx</sub>	V	
Input Low Voltage	V <sub>ILtri</sub>		-0.3		0.25 V <sub>DDx</sub>	V	
Input Current	I <sub>IN</sub>	Single-ended inputs, V <sub>IN</sub> = GND, V <sub>IN</sub> = VDD	-5		5	uA	
	I <sub>INP</sub>	Single-ended inputs V <sub>IN</sub> = 0 V; Inputs with internal pull-up resistors V <sub>IN</sub> = VDD; Inputs with internal pull-down resistors	-50		50	uA	
Input Frequency	F <sub>IN</sub>	Bypass mode	1		200	MHz	2
		100MHz PLL mode	60	100.00	140	MHz	2
		50MHz PLL mode	30	50.00	65	MHz	2
		125MHz PLL mode	75	125.00	175	MHz	2
Pin Inductance	L <sub>pin</sub>			7	nH	1	
Capacitance	C <sub>IN</sub>	Logic Inputs, except DIF_IN	1.5		5	pF	1
	C <sub>INDIF_IN</sub>	DIF_IN differential clock inputs	1.5		2.7	pF	1
	C <sub>OUT</sub>	Output pin capacitance			6	pF	1
Clk Stabilization	T <sub>STAB</sub>	From V <sub>DD</sub> Power-Up and after input clock stabilization or de-assertion of PD# to 1st clock			1	ms	1,2
Input SS Modulation Frequency PCIe	f <sub>MODINPCIe</sub>	Allowable Frequency for PCIe Applications (Triangular Modulation)	30		33	kHz	
Input SS Modulation Frequency non-PCIe	f <sub>MODIN</sub>	Allowable Frequency for non-PCIe Applications (Triangular Modulation)	0		66	kHz	
OE# Latency	t <sub>LATOE#</sub>	DIF start after OE# assertion DIF stop after OE# deassertion	1		3	clocks	1,3
Tdrive_PD#	t <sub>DRVPD</sub>	DIF output enable after PD# de-assertion			300	us	1,3
Tfall	t <sub>F</sub>	Fall time of single-ended control inputs			5	ns	2
Trise	t <sub>R</sub>	Rise time of single-ended control inputs			5	ns	2

<sup>1</sup>Guaranteed by design and characterization, not 100% tested in production.

<sup>2</sup>Control input must be monotonic from 20% to 80% of input swing.

<sup>3</sup>Time from deassertion until outputs are >200 mV

## Electrical Characteristics–DIF Low-Power HCSL Outputs

TA = T<sub>AMB</sub>, Supply Voltages per normal operation conditions, See Test Loads for Loading Conditions

PARAMETER	SYMBOL	CONDITIONS	MIN	TYP	MAX	UNITS	NOTES
Slew rate	dV/dt	Scope averaging on, fast setting	2	2.8	4	V/ns	1,2,3
	dV/dt	Scope averaging on, slow setting	1.2	1.9	3.1	V/ns	1,2,3
Slew rate matching	$\Delta$ dV/dt	Slew rate matching		7	20	%	1,2,4
Voltage High	V <sub>HIGH</sub>	Statistical measurement on single-ended signal using oscilloscope math function. (Scope averaging on)	660	768	850	mV	7
Voltage Low	V <sub>LOW</sub>		-150	-11	150		7
Max Voltage	V <sub>max</sub>	Measurement on single ended signal using absolute value. (Scope averaging off)		811	1150	mV	7
Min Voltage	V <sub>min</sub>		-300	-49			7
Crossing Voltage (abs)	V <sub>cross_abs</sub>	Scope averaging off	250	357	550	mV	1,5
Crossing Voltage (var)	$\Delta$ -V <sub>cross</sub>	Scope averaging off		14	140	mV	1,6

<sup>1</sup>Guaranteed by design and characterization, not 100% tested in production.

<sup>2</sup> Measured from differential waveform

<sup>3</sup> Slew rate is measured through the V<sub>swing</sub> voltage range centered around differential 0V. This results in a +/-150mV window around differential 0V.

<sup>4</sup> Matching applies to rising edge rate for Clock and falling edge rate for Clock#. It is measured using a +/-75mV window centered on the average cross point where Clock rising meets Clock# falling. The median cross point is used to calculate the voltage thresholds the oscilloscope is to use for the edge rate calculations.

<sup>5</sup> V<sub>cross</sub> is defined as voltage where Clock = Clock# measured on a component test board and only applies to the differential rising edge (i.e. Clock rising and Clock# falling).

<sup>6</sup> The total variation of all V<sub>cross</sub> measurements in any particular system. Note that this is a subset of V<sub>cross\_min/max</sub> (V<sub>cross</sub> absolute) allowed. The intent is to limit V<sub>cross</sub> induced modulation by setting  $\Delta$ -V<sub>cross</sub> to be smaller than V<sub>cross</sub> absolute.

<sup>7</sup> At default SMBus settings.

## Electrical Characteristics–Current Consumption

TA = T<sub>AMB</sub>, Supply Voltages per normal operation conditions, See Test Loads for Loading Conditions

PARAMETER	SYMBOL	CONDITIONS	MIN	TYP	MAX	UNITS	NOTES
Operating Supply Current	I <sub>DDA</sub>	VDDA, PLL Mode, @100MHz		7	15	mA	
	I <sub>DD</sub>	VDDx, All outputs active @100MHz		17	22	mA	
	I <sub>DDIO</sub>	VDDIO, All outputs active @100MHz		20	25	mA	
Powerdown Current	I <sub>DDAPD</sub>	VDDA, CKPWRGD_PD#=0		0.6	2	mA	2
	I <sub>DDPD</sub>	VDDx, CKPWRGD_PD#=0		3.8	6	mA	2
	I <sub>DDIOPD</sub>	VDDIO, CKPWRGD_PD#=0		0.04	0.10	mA	2

<sup>1</sup> Guaranteed by design and characterization, not 100% tested in production.

<sup>2</sup> Input clock stopped.

## Electrical Characteristics–Output Duty Cycle, Jitter, Skew and PLL Characteristics

TA = T<sub>AMB</sub>, Supply Voltages per normal operation conditions, See Test Loads for Loading Conditions

PARAMETER	SYMBOL	CONDITIONS	MIN	TYP	MAX	UNITS	NOTES
PLL Bandwidth	BW	-3dB point in High BW Mode (100MHz)	2	3.3	4	MHz	1,5
		-3dB point in Low BW Mode (100MHz)	1	1.5	2	MHz	1,5
PLL Jitter Peaking	t <sub>JPEAK</sub>	Peak Pass band Gain (100MHz)		0.8	2	dB	1
Duty Cycle	t <sub>DC</sub>	Measured differentially, PLL Mode	45	50	55	%	1
Duty Cycle Distortion	t <sub>DCD</sub>	Measured differentially, Bypass Mode	-1	0.0	1	%	1,3
Skew, Input to Output	t <sub>pdBYP</sub>	Bypass Mode, V <sub>T</sub> = 50%	2500	3406	4500	ps	1
	t <sub>pdPLL</sub>	PLL Mode V <sub>T</sub> = 50%	-100	8	100	ps	1,4
Skew, Output to Output	t <sub>sk3</sub>	V <sub>T</sub> = 50%		21	55	ps	1,4
		PLL mode		15	50	ps	1,2
Jitter, Cycle to cycle	t <sub>jcy-cyc</sub>			0.1	1	ps	1,2
		Additive Jitter in Bypass Mode					

<sup>1</sup> Guaranteed by design and characterization, not 100% tested in production.

<sup>2</sup> Measured from differential waveform

<sup>3</sup> Duty cycle distortion is the difference in duty cycle between the output and the input clock when the device is operated in bypass mode.

<sup>4</sup> All outputs at default slew rate

<sup>5</sup> The MIN/TYP/MAX values of each BW setting track each other, i.e., Low BW MAX will never occur with Hi BW MIN.

## Electrical Characteristics–Filtered Phase Jitter Parameters - PCIe Common Clocked (CC) Architectures

T<sub>AMB</sub> = over the specified operating range. Supply Voltages per normal operation conditions, See Test Loads for Loading Conditions

PARAMETER	SYMBOL	CONDITIONS	MIN	TYP	MAX	INDUSTRY LIMIT	UNITS	Notes
Phase Jitter, PLL Mode	t <sub>jphPCIeG1-CC</sub>	PCIe Gen 1		23	32	86	ps (p-p)	1,2,3,5
	t <sub>jphPCIeG2-CC</sub>	PCIe Gen 2 Lo Band 10kHz < f < 1.5MHz (PLL BW of 5-16MHz or 8-5MHz, CDR = 5MHz)		0.6	0.8	3	ps (rms)	1,2,5
		PCIe Gen 2 High Band 1.5MHz < f < Nyquist (50MHz) (PLL BW of 5-16MHz or 8-5MHz, CDR = 5MHz)		1.7	2.1	3.1	ps (rms)	1,2,5
	t <sub>jphPCIeG3-CC</sub>	PCIe Gen 3 (PLL BW of 2-4MHz or 2-5MHz, CDR = 10MHz)		0.4	0.48	1	ps (rms)	1,2,5
	t <sub>jphPCIeG4-CC</sub>	PCIe Gen 4 (PLL BW of 2-4MHz or 2-5MHz, CDR = 10MHz)		0.4	0.48	0.5	ps (rms)	1,2,5
Additive Phase Jitter, Bypass mode	t <sub>jphPCIeG1-CC</sub>	PCIe Gen 1		0.0	0.01	n/a	ps (p-p)	1,2,5
	t <sub>jphPCIeG2-CC</sub>	PCIe Gen 2 Lo Band 10kHz < f < 1.5MHz (PLL BW of 5-16MHz or 8-5MHz, CDR = 5MHz)		0.0	0.01		ps (rms)	1,2,4,5
		PCIe Gen 2 High Band 1.5MHz < f < Nyquist (50MHz) (PLL BW of 5-16MHz or 8-5MHz, CDR = 5MHz)		0.0	0.01		ps (rms)	1,2,4,5
	t <sub>jphPCIeG3-CC</sub>	PCIe Gen 3 (PLL BW of 2-4MHz or 2-5MHz, CDR = 10MHz)		0.0	0.01		ps (rms)	1,2,4,5
	t <sub>jphPCIeG4-CC</sub>	PCIe Gen 4 (PLL BW of 2-4MHz or 2-5MHz, CDR = 10MHz)		0.0	0.01		ps (rms)	1,2,4,5

<sup>1</sup> Applies to all outputs.

<sup>2</sup> Based on PCIe Base Specification Rev4.0 version 0.7draft. See <http://www.pcisig.com> for latest specifications.

<sup>3</sup> Sample size of at least 100K cycles. This figures extrapolates to 108ps pk-pk @ 1M cycles for a BER of 1-12.

<sup>4</sup> For RMS values additive jitter is calculated by solving the following equation for b [ $a^2 + b^2 = c^2$ ] where a is rms input jitter and c is rms total jitter.

<sup>5</sup> Driven by 9FGL0841 or equivalent



## Electrical Characteristics–Filtered Phase Jitter Parameters - PCIe Separate Reference Independent Spread (SRIS) Architectures<sup>5</sup>

T<sub>AMB</sub> = over the specified operating range. Supply Voltages per normal operation conditions, See Test Loads for Loading Conditions

PARAMETER	SYMBOL	CONDITIONS	MIN	TYP	MAX	INDUSTRY LIMIT	UNITS	Notes
Phase Jitter, PLL Mode	t <sub>jphPCIeG2-SRIS</sub>	PCIe Gen 2 (PLL BW of 16MHz , CDR = 5MHz)		1.2	1.5	2	ps (rms)	1,2
	t <sub>jphPCIeG3-SRIS</sub>	PCIe Gen 3 (PLL BW of 2-4MHz or 2-5MHz, CDR = 10MHz)		n/a		0.5	ps (rms)	1,2,6
Additive Phase Jitter, Bypass mode	t <sub>jphPCIeG2-SRIS</sub>	PCIe Gen 2 (PLL BW of 16MHz , CDR = 5MHz)		0.0	0.01	n/a	ps (rms)	1,2,4
	t <sub>jphPCIeG3-SRIS</sub>	PCIe Gen 3 (PLL BW of 2-4MHz or 2-5MHz, CDR = 10MHz)		0.0	0.01		ps (rms)	1,2,4,6

<sup>1</sup> Applies to all outputs.

<sup>2</sup> Based on PCIe Base Specification Rev3.1a. These filters are different than Common Clock filters. See <http://www.pcisig.com> for latest specifications.

<sup>3</sup> Sample size of at least 100K cycles. This figures extrapolates to 108ps pk-pk @ 1M cycles for a BER of 1-12.

<sup>4</sup> For RMS values, additive jitter is calculated by solving the following equation for b [ $a^2+b^2=c^2$ ] where a is rms input jitter and c is rms total jitter.

<sup>5</sup> As of PCIe Base Specification Rev4.0 draft 0.7, SRIS is not currently defined for Gen1 or Gen4.

<sup>6</sup> This device does not support PCIe Gen3 SRIS in PLL mode. It supports PCIe Gen3 SRIS in bypass mode.

## Electrical Characteristics– Unfiltered Phase Jitter Parameters

T<sub>A</sub> = T<sub>AMB</sub>, Supply Voltages per normal operation conditions, See Test Loads for Loading Conditions

PARAMETER	SYMBOL	CONDITIONS	MIN	TYP	MAX	INDUSTRY LIMIT	UNITS	Notes
Additive Phase Jitter, Fanout Mode	t <sub>jph156M</sub>	156.25MHz, 1.5MHz to 10MHz, -20dB/decade rollover < 1.5MHz, -40db/decade rolloff > 10MHz		159		N/A	fs (rms)	1,2,3
	t <sub>jph156M12k-20</sub>	156.25MHz, 12kHz to 20MHz, -20dB/decade rollover < 12kHz, -40db/decade rolloff > 20MHz		363		N/A	fs (rms)	1,2,3

<sup>1</sup> Guaranteed by design and characterization, not 100% tested in production.

<sup>2</sup> DRiven by Rohde&Schartz SMA100

<sup>3</sup> For RMS figures, additive jitter is calculated by solving the following equation: Additive jitter = SQRT[(total jitter)<sup>2</sup> - (input jitter)<sup>2</sup>]

## General SMBus Serial Interface Information

### How to Write

- Controller (host) sends a start bit
- Controller (host) sends the write address
- IDT clock will **acknowledge**
- Controller (host) sends the beginning byte location = N
- IDT clock will **acknowledge**
- Controller (host) sends the byte count = X
- IDT clock will **acknowledge**
- Controller (host) starts sending Byte N through Byte N+X-1
- IDT clock will **acknowledge** each byte **one at a time**
- Controller (host) sends a Stop bit

Index Block Write Operation			
Controller (Host)			IDT (Slave/Receiver)
T	starT bit		
Slave Address			
WR	WRite		
			ACK
Beginning Byte = N			
			ACK
Data Byte Count = X			
			ACK
Beginning Byte N		X Byte	
O			ACK
O			O
O			O
			O
Byte N + X - 1			
			ACK
P	stoP bit		

### How to Read

- Controller (host) will send a start bit
- Controller (host) sends the write address
- IDT clock will **acknowledge**
- Controller (host) sends the beginning byte location = N
- IDT clock will **acknowledge**
- Controller (host) will send a separate start bit
- Controller (host) sends the read address
- IDT clock will **acknowledge**
- IDT clock will send the data byte count = X
- IDT clock sends Byte N+X-1
- IDT clock sends **Byte 0 through Byte X (if X<sub>(H)</sub> was written to Byte 8)**
- Controller (host) will need to acknowledge each byte
- Controller (host) will send a not acknowledge bit
- Controller (host) will send a stop bit

Index Block Read Operation			
Controller (Host)			IDT (Slave/Receiver)
T	starT bit		
Slave Address			
WR	WRite		
			ACK
Beginning Byte = N			
			ACK
RT	Repeat starT		
Slave Address			
RD	ReaD		
			ACK
			Data Byte Count=X
ACK		X Byte	
ACK			Beginning Byte N
			O
			O
			O
			Byte N + X - 1
N	Not acknowledge		
P	stoP bit		

**Note: SMBus Address is Latched on SADR pin.**  
**Unless otherwise indicated, default values are for the 641 and 0651. P1 devices are fully factory programmable.**

**SMBus Table: Output Enable Register <sup>1</sup>**

Byte 0	Name	Control Function	Type	0	1	Default
Bit 7	DIF OE5	Output Enable	RW	See B11[1:0]	Pin Control	1
Bit 6	DIF OE4	Output Enable	RW		Pin Control	1
Bit 5	Reserved					0
Bit 4	DIF OE3	Output Enable	RW	See B11[1:0]	Pin Control	1
Bit 3	DIF OE2	Output Enable	RW		Pin Control	1
Bit 2	DIF OE1	Output Enable	RW		Pin Control	1
Bit 1	Reserved					0
Bit 0	DIF OE0	Output Enable	RW	See B11[1:0]	Pin Control	1

1. A low on these bits will override the OE# pin and force the differential output to the state indicated by B11[1:0] (Low/Low default)

**SMBus Table: PLL Operating Mode and Output Amplitude Control Register**

Byte 1	Name	Control Function	Type	0	1	Default
Bit 7	PLLMODERB1	PLL Mode Readback Bit 1	R	See PLL Operating Mode Table		Latch
Bit 6	PLLMODERB0	PLL Mode Readback Bit 0	R			Latch
Bit 5	PLLMODE_SWCNTRL	Enable SW control of PLL Mode	RW	Values in B1[7:6] set PLL Mode	Values in B1[4:3] set PLL Mode	0
Bit 4	PLLMODE1	PLL Mode Control Bit 1	RW <sup>1</sup>	See PLL Operating Mode Table		0
Bit 3	PLLMODE0	PLL Mode Control Bit 0	RW <sup>1</sup>			0
Bit 2	Reserved					1
Bit 1	AMPLITUDE 1	Controls Output Amplitude	RW	00 = 0.6V	01 = 0.68V	1
Bit 0	AMPLITUDE 0		RW	10 = 0.75V	11 = 0.85V	0

1. B1[5] must be set to a 1 for these bits to have any effect on the part.

**SMBus Table: Slew Rate Control Register**

Byte 2	Name	Control Function	Type	0	1	Default
Bit 7	SLEWRATESEL DIF5	Slew rate selection	RW	Slow Setting	Fast Setting	1
Bit 6	SLEWRATESEL DIF4	Slew rate selection	RW	Slow Setting	Fast Setting	1
Bit 5	Reserved					1
Bit 4	SLEWRATESEL DIF3	Slew rate selection	RW	Slow Setting	Fast Setting	1
Bit 3	SLEWRATESEL DIF2	Slew rate selection	RW	Slow Setting	Fast Setting	1
Bit 2	SLEWRATESEL DIF1	Slew rate selection	RW	Slow Setting	Fast Setting	1
Bit 1	Reserved					1
Bit 0	SLEWRATESEL DIF0	Slew rate selection	RW	Slow Setting	Fast Setting	1

Note: See "Low-Power HCSL Outputs" table for slew rates.

**SMBus Table: Slew Rate Control Register**

Byte 3	Name	Control Function	Type	0	1	Default
Bit 7	Reserved					1
Bit 6	Reserved					1
Bit 5	FREQ_SEL_EN	Enable SW selection of frequency	RW	SW frequency change disabled	SW frequency change enabled	0
Bit 4	FSEL1	Freq. Select Bit 1	RW <sup>1</sup>	00 = 100M, 10 = 125M 01 = 50M, 11 = Reserved		0
Bit 3	FSEL0	Freq. Select Bit 0	RW <sup>1</sup>			0
Bit 2	Reserved					1
Bit 1	Reserved					1
Bit 0	SLEWRATESEL FB	Adjust Slew Rate of FB	RW	Slow Setting	Fast Setting	1

1. B3[5] must be set to a 1 for these bits to have any effect on the part.

Byte 4 is Reserved

**SMBus Table: Revision and Vendor ID Register**

Byte 5	Name	Control Function	Type	0	1	Default
Bit 7	RID3	Revision ID	R	B rev = 0001		0
Bit 6	RID2		R			0
Bit 5	RID1		R			0
Bit 4	RID0		R			1
Bit 3	VID3	VENDOR ID	R	0001 = IDT		0
Bit 2	VID2		R			0
Bit 1	VID1		R			0
Bit 0	VID0		R			1

**SMBus Table: Device Type/Device ID**

Byte 6	Name	Control Function	Type	0	1	Default
Bit 7	Device Type1	Device Type	RW	00 = FGx, 01 = DBx ZDB/FOB, 10 = DMx, 11= DBx FOB		0
Bit 6	Device Type0		RW			1
Bit 5	Device ID5	Device ID	RW	000110binary or 06 hex		0
Bit 4	Device ID4		RW			0
Bit 3	Device ID3		RW			0
Bit 2	Device ID2		RW			1
Bit 1	Device ID1		RW			1
Bit 0	Device ID0		RW			0

**SMBus Table: Byte Count Register**

Byte 7	Name	Control Function	Type	0	1	Default
Bit 7		Reserved				0
Bit 6		Reserved				0
Bit 5		Reserved				0
Bit 4	BC4	Byte Count Programming	RW	Writing to this register will configure how many bytes will be read back, default is = 8 bytes.		0
Bit 3	BC3		RW			1
Bit 2	BC2		RW			0
Bit 1	BC1		RW			0
Bit 0	BC0		RW			0

Bytes 8 and 9 are Reserved

**SMBus Table: PD\_Restore**

Byte 10	Name	Control Function	Type	0	1	Default
Bit 7		Reserved				1
Bit 6	Power-Down (PD) Restore	Restore Default Config. In PD	RW	Clear Config in PD	Keep Config in PD	1
Bit 5		Reserved				0
Bit 4		Reserved				0
Bit 3		Reserved				0
Bit 2		Reserved				0
Bit 1		Reserved				0
Bit 0		Reserved				0

**SMBus Table: Stop State and Impedance Control**

Byte 11	Name	Control Function	Type	0	1	Default
Bit 7	FB_imp[1]	FB Zout	RW	00=33Ω DIF Zout	10=100Ω DIF Zout	see Note
Bit 6	FB_imp[0]	FB Zout	RW	01=85Ω DIF Zout	11 = Reserved	
Bit 5	Reserved					0
Bit 4	Reserved					0
Bit 3	Reserved					0
Bit 2	Reserved					0
Bit 1	STP[1]	True/Complement DIF Output Disable State	RW	00 = Low/Low	10 = High/Low	0
Bit 0	STP[0]		RW	01 = HiZ/HiZ	11 = Low/High	0

Note: xx41 = 10, xx51 = 01, P1 = factory programmable.

**SMBus Table: Impedance Control**

Byte 12	Name	Control Function	Type	0	1	Default
Bit 7	DIF2_imp[1]	DIF2 Zout	RW	00=33Ω DIF Zout	10=100Ω DIF Zout	see Note
Bit 6	DIF2_imp[0]	DIF2 Zout	RW	01=85Ω DIF Zout	11 = Reserved	
Bit 5	DIF1_imp[1]	DIF1 Zout	RW	00=33Ω DIF Zout	10=100Ω DIF Zout	
Bit 4	DIF1_imp[0]	DIF1 Zout	RW	01=85Ω DIF Zout	11 = Reserved	
Bit 3	Reserved					X
Bit 2	Reserved					X
Bit 1	DIF0_imp[1]	DIF0 Zout	RW	00=33Ω DIF Zout	10=100Ω DIF Zout	see Note
Bit 0	DIF0_imp[0]	DIF0 Zout	RW	01=85Ω DIF Zout	11 = Reserved	

Note: xx41 = 10, xx51 = 01, P1 = factory programmable.

**SMBus Table: Impedance Control**

Byte 13	Name	Control Function	Type	0	1	Default
Bit 7	DIF5_imp[1]	DIF5 Zout	RW	00=33Ω DIF Zout	10=100Ω DIF Zout	see Note
Bit 6	DIF5_imp[0]	DIF5 Zout	RW	01=85Ω DIF Zout	11 = Reserved	
Bit 5	DIF4_imp[1]	DIF4 Zout	RW	00=33Ω DIF Zout	10=100Ω DIF Zout	
Bit 4	DIF4_imp[0]	DIF6 Zout	RW	01=85Ω DIF Zout	11 = Reserved	
Bit 3	Reserved					X
Bit 2	Reserved					X
Bit 1	DIF3_imp[1]	DIF3 Zout	RW	00=33Ω DIF Zout	10=100Ω DIF Zout	see Note
Bit 0	DIF3_imp[0]	DIF3 Zout	RW	01=85Ω DIF Zout	11 = Reserved	

Note: xx41 = 10, xx51 = 01, P1 = factory programmable.

**SMBus Table: Pull-up Pull-down Control**

Byte 14	Name	Control Function	Type	0	1	Default
Bit 7	OE2_pu/pd[1]	OE2 Pull-up(PuP)/ Pull-down(Pdwn) control	RW	00=None	10=Pup	0
Bit 6	OE2_pu/pd[0]		RW	01=Pdwn	11 = Pup+Pdwn	1
Bit 5	OE1_pu/pd[1]	OE1 Pull-up(PuP)/ Pull-down(Pdwn) control	RW	00=None	10=Pup	0
Bit 4	OE1_pu/pd[0]		RW	01=Pdwn	11 = Pup+Pdwn	1
Bit 3	Reserved					X
Bit 2	Reserved					X
Bit 1	OE0_pu/pd[1]	OE0 Pull-up(PuP)/ Pull-down(Pdwn) control	RW	00=None	10=Pup	0
Bit 0	OE0_pu/pd[0]		RW	01=Pdwn	11 = Pup+Pdwn	1

Note: These values are for xx41 and xx51. P1 is factory programmable.

**SMBus Table: Pull-up Pull-down Control**

Byte 15	Name	Control Function	Type	0	1	Default
Bit 7	OE5_pu/pd[1]	OE5 Pull-up(PuP)/ Pull-down(Pdwn) control	RW	00=None	10=Pup	0
Bit 6	OE5_pu/pd[0]		RW	01=Pdwn	11 = Pup+Pdwn	1
Bit 5	OE4_pu/pd[1]	OE4 Pull-up(PuP)/ Pull-down(Pdwn) control	RW	00=None	10=Pup	0
Bit 4	OE4_pu/pd[0]		RW	01=Pdwn	11 = Pup+Pdwn	1
Bit 3	Reserved					X
Bit 2	Reserved					X
Bit 1	OE3_pu/pd[1]	OE3 Pull-up(PuP)/ Pull-down(Pdwn) control	RW	00=None	10=Pup	0
Bit 0	OE3_pu/pd[0]		RW	01=Pdwn	11 = Pup+Pdwn	1

Note: These values are for xx41 and xx51. P1 is factory programmable.

**SMBus Table: Pull-up Pull-down Control**

Byte 16	Name	Control Function	Type	0	1	Default
Bit 7	Reserved					0
Bit 6	Reserved					0
Bit 5	Reserved					0
Bit 4	Reserved					0
Bit 3	Reserved					X
Bit 2	Reserved					X
Bit 1	CKPWRGD_PD_pu/pd[1]	CKPWRGD_PD Pull-up(PuP)/ Pull-down(Pdwn) control	RW	00=None	10=Pup	1
Bit 0	CKPWRGD_PD_pu/pd[0]		RW	01=Pdwn	11 = Pup+Pdwn	0

\* 9DBL09xx devices only.

Note: These values are for xx41 and xx51. P1 is factory programmable.

Bytes 17 is Reserved and reads back 0h00.

**SMBus Table: Polarity Control**

Byte 18	Name	Control Function	Type	0	1	Default
Bit 7	OE5_polarity	Sets OE5 polarity	RW	Enabled when Low	Enabled when High	0
Bit 6	OE4_polarity	Sets OE4 polarity	RW	Enabled when Low	Enabled when High	0
Bit 5	Reserved					0
Bit 4	OE3_polarity	Sets OE3 polarity	RW	Enabled when Low	Enabled when High	0
Bit 3	OE2_polarity	Sets OE2 polarity	RW	Enabled when Low	Enabled when High	0
Bit 2	OE1_polarity	Sets OE1 polarity	RW	Enabled when Low	Enabled when High	0
Bit 1	Reserved					0
Bit 0	OE0_polarity	Sets OE0 polarity	RW	Enabled when Low	Enabled when High	0

**SMBus Table: Polarity Control**

Byte 19	Name	Control Function	Type	0	1	Default
Bit 7	Reserved					0
Bit 6	Reserved					0
Bit 5	Reserved					0
Bit 4	Reserved					0
Bit 3	Reserved					0
Bit 2	Reserved					0
Bit 1	Reserved					0
Bit 0	CKPWRGD_PD	Determines CKPWRGD_PD polarity	RW	Power Down when Low	Power Down when High	0

## Marking Diagrams

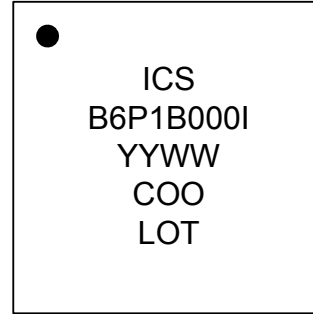
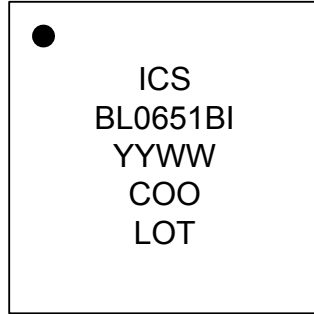
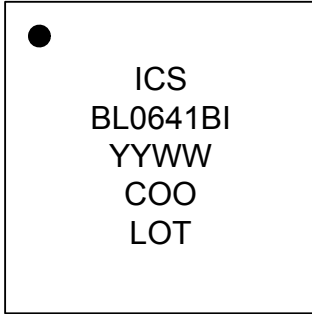

### Notes:

1. "LOT" is the lot sequence number.
2. "COO" denotes country of origin.
3. YYWW is the last two digits of the year and week that the part was assembled.
4. Line 2: truncated part number
5. "I" denotes industrial temperature range device.

## Thermal Characteristics

PARAMETER	SYMBOL	CONDITIONS	PKG	TYP. VALUE	UNITS	NOTES
Thermal Resistance	$\theta_{JC}$	Junction to Case	NDG40	42	°C/W	1
	$\theta_{Jb}$	Junction to Base		2.4	°C/W	1
	$\theta_{JA0}^{\dagger}$	Junction to Air, still air		39	°C/W	1
	$\theta_{JA1}$	Junction to Air, 1 m/s air flow		33	°C/W	1
	$\theta_{JA3}$	Junction to Air, 3 m/s air flow		28	°C/W	1
	$\theta_{JA5}$	Junction to Air, 5 m/s air flow		27	°C/W	1

<sup>†</sup>ePad soldered to board

# Package Outline and Dimensions (NDG40)

REVISIONS			
REV	DESCRIPTION	DATE	APPROVED
00	INITIAL RELEASE	5/17/16	JH

SYMBOL	DIMENSION		
	MIN	NOM	MAX
b	0.15	0.20	0.25
D	5.00 BSC		
E	5.00 BSC		
D2	3.40	3.50	3.60
E2	3.40	3.50	3.60
L	0.30	0.40	0.50
e	0.40 BSC		
N	40		
ND	10 (note 3)		
NE	10 (note 3)		
A	0.80	0.90	1.00
A1	0.00	0.02	0.05
A3	0.2 REF		
k	0.35 REF		
ooo	0.10		
bbb	0.07		
ccc	0.10		
ddd	0.05		
eee	0.08		
fff	0.10		

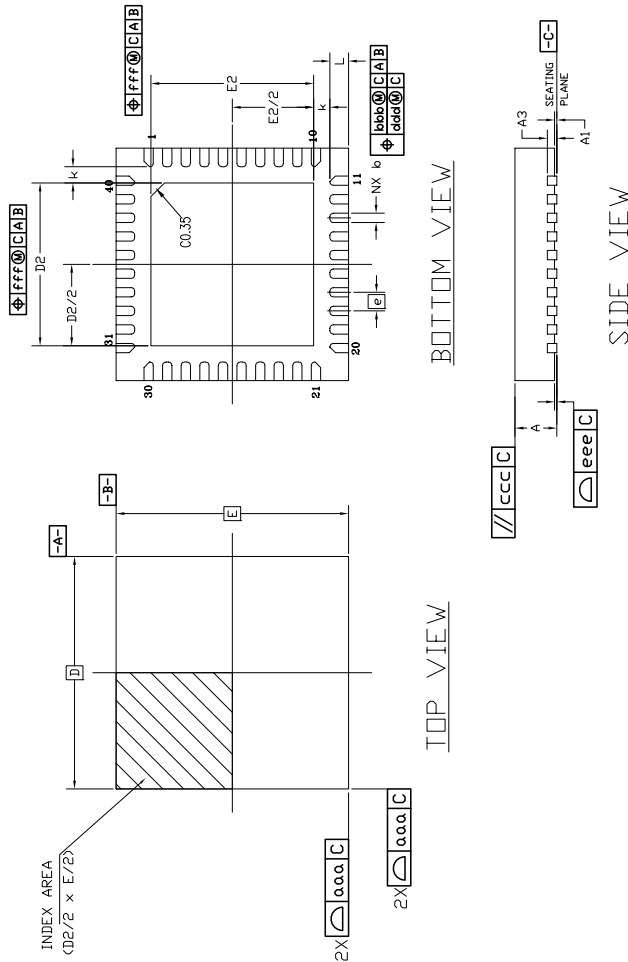

NOTES:

1. ALL DIMENSIONING AND TOLERANCING CONFORM TO ANSI Y14.5M-1982
2. ALL DIMENSIONS ARE IN MILLIMETERS.
3. ND AND NE REFER TO THE NUMBER OF TERMINALS ON EACH D AND E SIDE RESPECTIVELY.

<b>TOLERANCES UNLESS SPECIFIED</b> DECIMAL ±1° XX±.05 XXX±.030		<b>APPROVALS</b> DRAWN <i>mm</i> CHECKED	
<b>DATE</b> 05/31/10		<b>DATE</b> 05/31/10	
<b>SIZE</b> C		<b>DRAWING No.</b> PSC-4292-02	
<b>DO NOT SCALE DRAWING</b>		<b>REV</b> 00	
		<b>SHEET</b> 1 OF 2	

6024 SILVER CREEK  
 VALLEY ROAD, SAN JOSE,  
 CA 95138  
 PHONE: (408) 284-8200  
 FAX: (408) 284-3572

**www.IDT.com**

**TITLE/NDG40 PACKAGE OUTLINE**  
 5.0 x 5.0 mm BODY, EPAD 3.50mm SQ.  
 0.40 mm PITCH QFN



# Package Outline and Dimensions, cont. (NDG40)

REVISIONS		
REV	DESCRIPTION	DATE
00	INITIAL RELEASE	5/17/16
	APPROVED	JH

RECOMMENDED LAND PATTERN

**NOTES:**

1. ALL DIMENSIONS ARE IN mm. ANGLES IN DEGREES.
2. TOP DOWN VIEW AS VIEWED ON PCB.
3. COMPONENT OUTLINE SHOWS FOR REFERENCE IN GREEN.
4. LAND PATTERN IN BLUE. NSMD PATTERN ASSUMED.
5. LAND PATTERN RECOMMENDATION PER IPC-7351B GENERIC REQUIREMENT FOR SURFACE MOUNT DESIGN AND LAND PATTERN.

TOLERANCES UNLESS SPECIFIED	6024 SILVER CREEK VALLEY ROAD, SAN JOSE, CA 95138 PHONE: (408) 284-8200 FAX: (408) 284-3572
DECIMAL ±1.1	<b>IDT™</b>
XXX ±.05	<b>www.IDT.com</b>
XXXX ±.30	TITLE: NDG40 PACKAGE OUTLINE
APPROVALS	DATE
DRAWN <i>7/08</i>	05/31/10
CHECKED	5.0 x 5.0 mm BODY, EPAD 3.50mm SQ. 0.40 mm PITCH QFN
SIZE	DRAWING No.
C	PSC-4292-02
DO NOT SCALE DRAWING	REV 00
	SHEET 2 OF 2

## Ordering Information

Part / Order Number	Output Impedance	Shipping Packaging	Package	Temperature
9DBL0641BKILF	100Ω	Trays	40-pin VFQFPN	-40 to +85° C
9DBL0641BKILFT		Tape and Reel	40-pin VFQFPN	-40 to +85° C
9DBL0651BKILF	85Ω	Trays	40-pin VFQFPN	-40 to +85° C
9DBL0651BKILFT		Tape and Reel	40-pin VFQFPN	-40 to +85° C
9DBL06P1BxxxKILF	Factory configurable. Contact IDT for additional information.	Trays	40-pin VFQFPN	-40 to +85° C
9DBL06P1BxxxKILFT		Tape and Reel	40-pin VFQFPN	-40 to +85° C

“LF” suffix to the part number are the Pb-Free configuration and are RoHS compliant.

“B” is the device revision designator (will not correlate with the datasheet revision).

“xxx” is a unique factory assigned number to identify a particular default configuration.

## Revision History

Rev.	Initiator	Issue Date	Description	Page #
B	RDW	6/2/2016	1. Electrical Table and SMBus Updates/Corrections 2. Release to final.	Various
C	RDW	6/7/2016	1. SMBus operating frequency is now set to 500kHz max. 2. Removed duplicate Absolute Maximum Table. 3. Corrected "Test Loads" table	Various
D	RDW	6/8/2016	1. Added Frequency Select info to Byte 3	11
E	RDW	6/14/2016	1. Updated IDD tables	7
F	RDW	9/2/2016	1. Corrected Byte 2 to properly indicate slew rate control bits	11
G	RDW	2/8/2017	Updated part numbering throughout datasheet to be 9DBL0641 / 9DBL0651	Various



**Corporate Headquarters**  
6024 Silver Creek Valley Road  
San Jose, CA 95138 USA  
[www.IDT.com](http://www.IDT.com)

**Sales**  
1-800-345-7015 or 408-284-8200  
Fax: 408-284-2775  
[www.IDT.com/go/sales](http://www.IDT.com/go/sales)

**Tech Support**  
[www.idt.com/go/support](http://www.idt.com/go/support)

DISCLAIMER Integrated Device Technology, Inc. (IDT) and its subsidiaries reserve the right to modify the products and/or specifications described herein at any time and at IDT's sole discretion. All information in this document, including descriptions of product features and performance, is subject to change without notice. Performance specifications and the operating parameters of the described products are determined in the independent state and are not guaranteed to perform the same way when installed in customer products. The information contained herein is provided without representation or warranty of any kind, whether express or implied, including, but not limited to, the suitability of IDT's products for any particular purpose, an implied warranty of merchantability, or non-infringement of the intellectual property rights of others. This document is presented only as a guide and does not convey any license under intellectual property rights of IDT or any third parties.

IDT's products are not intended for use in applications involving extreme environmental conditions or in life support systems or similar devices where the failure or malfunction of an IDT product can be reasonably expected to significantly affect the health or safety of users. Anyone using an IDT product in such a manner does so at their own risk, absent an express, written agreement by IDT.

Integrated Device Technology, IDT and the IDT logo are registered trademarks of IDT. Product specification subject to change without notice. Other trademarks and service marks used herein, including protected names, logos and designs, are the property of IDT or their respective third party owners.

Copyright ©2017 Integrated Device Technology, Inc.. All rights reserved.



## Стандарт Электрон Связь

Мы молодая и активно развивающаяся компания в области поставок электронных компонентов. Мы поставляем электронные компоненты отечественного и импортного производства напрямую от производителей и с крупнейших складов мира.

Благодаря сотрудничеству с мировыми поставщиками мы осуществляем комплексные и плановые поставки широчайшего спектра электронных компонентов.

Собственная эффективная логистика и склад в обеспечивает надежную поставку продукции в точно указанные сроки по всей России.

Мы осуществляем техническую поддержку нашим клиентам и предпродажную проверку качества продукции. На все поставляемые продукты мы предоставляем гарантию .

Осуществляем поставки продукции под контролем ВП МО РФ на предприятия военно-промышленного комплекса России , а также работаем в рамках 275 ФЗ с открытием отдельных счетов в уполномоченном банке. Система менеджмента качества компании соответствует требованиям ГОСТ ISO 9001.

Минимальные сроки поставки, гибкие цены, неограниченный ассортимент и индивидуальный подход к клиентам являются основой для выстраивания долгосрочного и эффективного сотрудничества с предприятиями радиоэлектронной промышленности, предприятиями ВПК и научно-исследовательскими институтами России.

С нами вы становитесь еще успешнее!

### Наши контакты:

**Телефон:** +7 812 627 14 35

**Электронная почта:** [sales@st-electron.ru](mailto:sales@st-electron.ru)

**Адрес:** 198099, Санкт-Петербург,  
Промышленная ул, дом № 19, литера Н,  
помещение 100-Н Офис 331