

## DIO2624

### 2-Vrms Audio Driver with Integrated 4-ch, 6<sup>th</sup>-Order SD and 1080i HD Video Filter

#### Features

- Line Output: able to drive 600Ω and 10kΩ
  - 2-Vrms With 3.3V Supply Voltage
  - No Pop/Clicks Noise at the line output when Power ON/OFF
  - No Need for Output DC-Blocking Capacitors
  - Accepting Differential Input
- Optimized Frequency Response between 20Hz–20kHz
- Video Filter: One CVBS channel with 6<sup>th</sup>-order, 9MHz filter
- Three channels with per channel a 6<sup>th</sup>-order, 37MHz filter
  - Drive Dual Video Load
  - Transparent Input Clamping
  - AC or DC Coupled Inputs/Outputs

#### Applications

- DVD Players
- Video Amplifiers
- Set-Top Boxes
- Personal Video Recorders
- Communications Devices

#### Descriptions

The DIO2624 is an integrated solution for Video driver and Audio driver, with two separated modules, the Audio Driver module and 4-ch 6<sup>th</sup>-order SD and 1080i HD Video filter driver module.

The Audio Driver allow for the removal of output AC-coupling capacitors. It is designed to optimize the audio driver circuit performance while reducing the BOM cost by eliminating the peripheral discrete components for noise reduction. Featuring differential input mode, gain range of  $\pm 1V/V$  to  $\pm 10V/V$  can be achieved via external gain resistor setting.

The Video filter integrates a single CVBS (SD) video driver plus a triple 1080i HD video driver. It can improve image quality compared to the passive LC filters. All channels can be directly driven by a DC-coupled or an AC-coupled signal. Internal diode-like clamps and bias circuitry may be used if AC-coupled inputs are required. The output in the video filter can also drive AC or DC coupled single (150Ω) or dual (75Ω) loads. The DC coupling capacitors can be removed.

#### Ordering Information

Order Part Number	Top Marking		T <sub>A</sub>	Package	
DIO2624XT28	DIO2624	Green/RoHS	-40 to +85°C	EP-TSSOP-28	Tape & Reel, 2500
DIO2624CT24	DIO2624	Green/RoHS	-40 to +85°C	TSSOP-24	Tape & Reel, 2500

## Pin Assignments

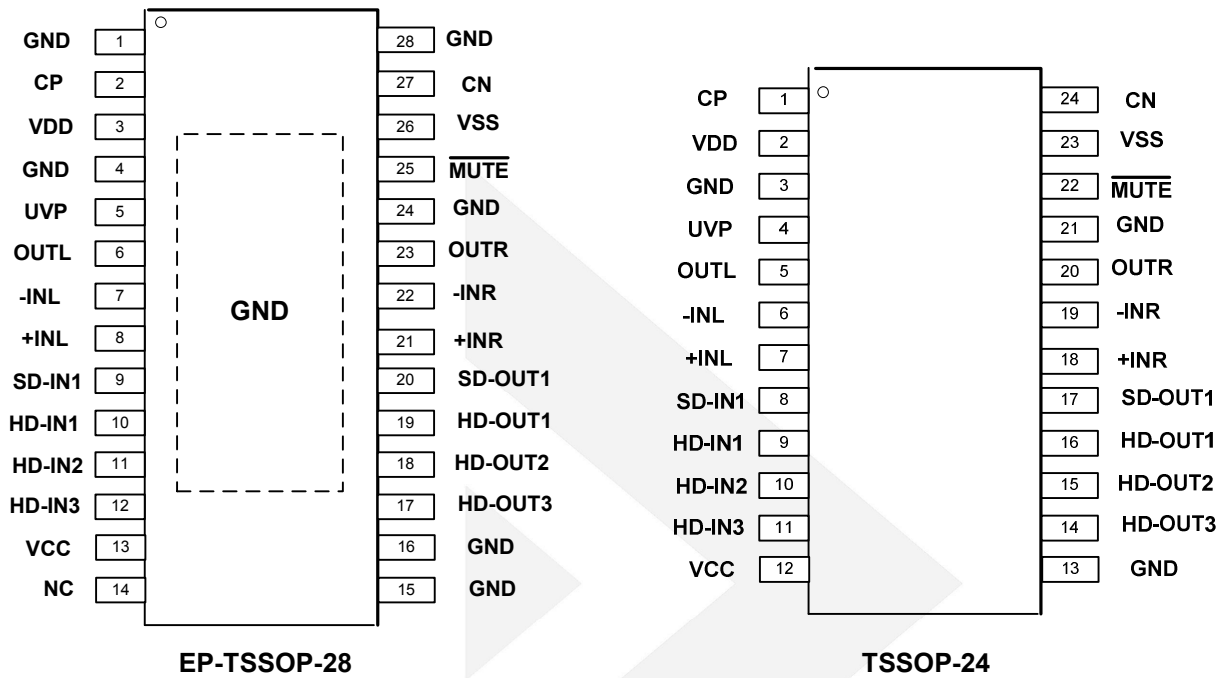

Figure 1 Pin Assignment

## Pin Description

Pin Name	Description
GND	GND
CP	Charge-pump flying capacitor positive terminal
VDD	Audio line driver positive supply
UVP	Under voltage protection input
OUTL	Left channel Output
-INL	Left channel Negative Input
+INL	Left channel Positive Input
SD-IN1	Channel SD Video Input
HD-IN1	Channel HD Video Input (Pr)
HD-IN2	Channel HD Video Input (Pb)
HD-IN3	Channel HD Video Input (Y)
VCC	Video filter driver power supply
HD-OUT3	Channel HD Video Output (Y)
HD-OUT2	Channel HD Video Output (Pb)
HD-OUT1	Channel HD Video Output (Pr)
SD-OUT1	Channel SD Video Output
+INR	Right channel Positive Input
-INR	Right channel Negative Input
OUTR	Right channel Output
MUTE	Mute input, active-low
VSS	Supply voltage output
CN	Charge-pump flying capacitor negative terminal
NC	No connect



# DIO2624

2-Vrms Audio Driver with Integrated 4-ch 6<sup>th</sup>-Order SD/HD Video Filter

## Block Diagram

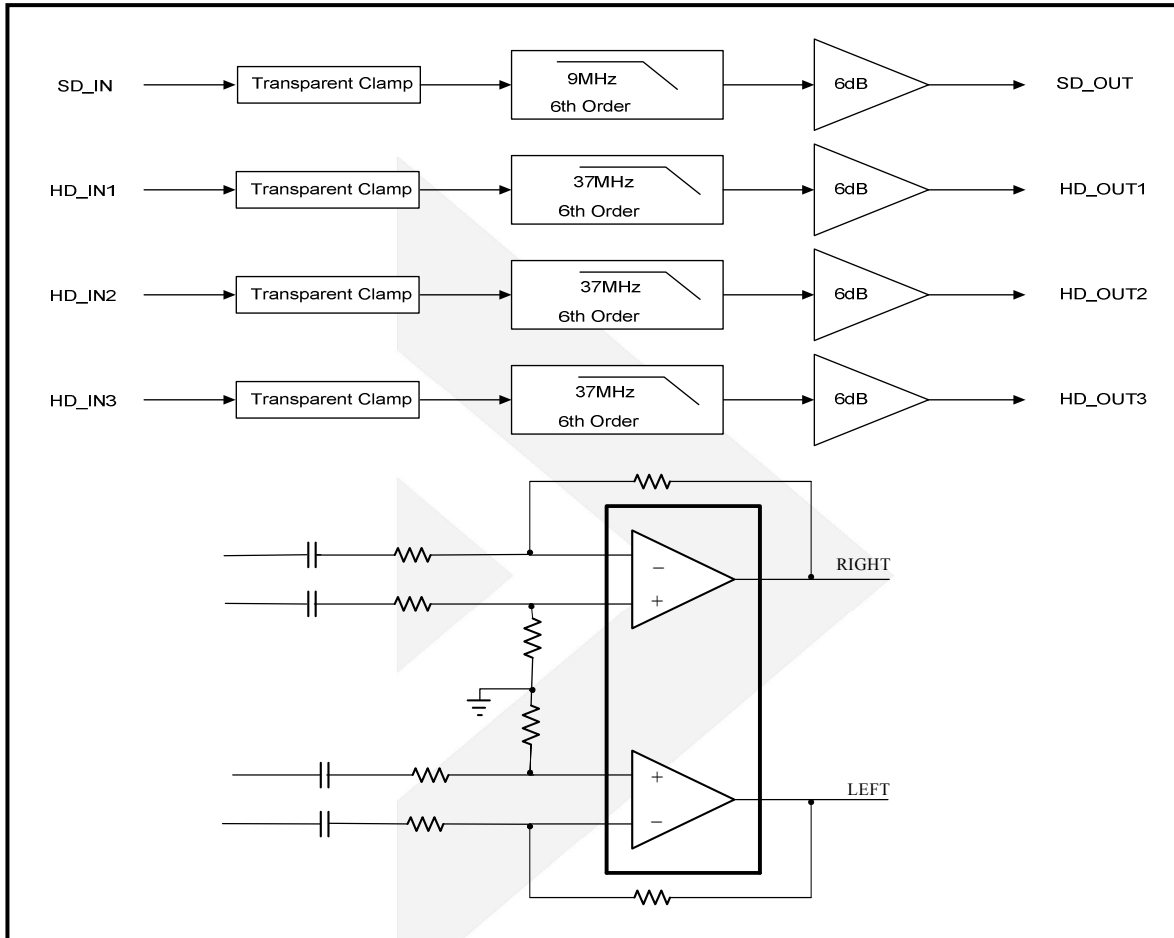

## Absolute Maximum Ratings

Stresses beyond those listed under "Absolute Maximum Rating" may cause permanent damage to the device. These are stress ratings only and functional operation of the device at these or any other condition beyond those indicated in the operational sections of the specifications is not implied. Exposure to absolute maximum rating conditions for extended periods may affect device reliability.

Parameter	Rating	Unit
Supply Voltage/VCC	0 to 6.0	V
Supply Voltage/VDD	-0.3 to 4	V
Input Voltage/VIN	-0.3 to $V_{CC}+0.3$	V
Input Voltage/-INR,-INL	$V_{SS}-0.3$ to $V_{DD}+0.3$	V
Minimum load impedance	600	$\Omega$
$Mut\bar{e}$ to GND	-0.3 to $V_{DD}+0.3$	V
Storage Temperature Range	-65 to 150	$^{\circ}\text{C}$
Junction Temperature	150	$^{\circ}\text{C}$
Lead Temperature Range	260	$^{\circ}\text{C}$
HBM ESD JEDEC: JESD22-A114	5	kV



# DIO2624

2-Vrms Audio Driver with Integrated 4-ch 6<sup>th</sup>-Order SD/HD Video Filter

## Recommended Operating Conditions

The Recommended Operating Conditions table defines the conditions for actual device operation to ensure optimal performance to the datasheet specifications. DIOO does not recommend exceeding them or designing to Absolute Maximum Ratings.

Symbol	Parameter	Min.	Typ.	Max.	Unit
VDD	Supply Voltage	3	3.3	3.6	V
VCC	Supply Voltage	3.135		5.25	V
V <sub>IH</sub>	Mute High level Input Voltage		60		% of V <sub>DD</sub>
V <sub>IL</sub>	Mute Low level Input Voltage		40		% of V <sub>DD</sub>
T <sub>A</sub>	Operating Temperature Range	-40		85	°C

**Notes:** The items below were divided into two parts, the Audio driver module and the Video filter module.

## Electrical Characteristics for the Audio Driver module

Typical value: T<sub>A</sub> = 25°C, V<sub>DD</sub>=3.3V, R<sub>L</sub>=10kΩ, C<sub>PUMP</sub>=C<sub>PVSS</sub>=1μF, R<sub>IN</sub>=15kΩ, R<sub>fb</sub>=30kΩ, unless otherwise specified.

Symbol	Parameter	Conditions	Min.	Typ.	Max.	Unit
V <sub>OS</sub>	Output Offset Voltage	V <sub>DD</sub> =3.3V, Input grounded, Unity gain		0.8		mV
PSRR	Power supply rejection ratio	V <sub>DD</sub> =3.3V		90		dB
V <sub>OH</sub>	High level output voltage	V <sub>DD</sub> =3.3V, R <sub>L</sub> =10kΩ	3.1			V
V <sub>OL</sub>	Low level output voltage	V <sub>DD</sub> =3.3V, R <sub>L</sub> =10kΩ			-3.05	V
I <sub>IH</sub>	Mute High level input current	V <sub>DD</sub> =3.3V, V <sub>I</sub> =V <sub>DD</sub>			1	μA
I <sub>IL</sub>	Mute Low level input current	V <sub>DD</sub> =3.3V, V <sub>I</sub> =0V			1	μA
I <sub>DD</sub>	Supply current	V <sub>DD</sub> =3.3V, V <sub>I</sub> =V <sub>DD</sub> , No load		16		mA
		Mute mode, V <sub>DD</sub> =3.3V		0.8		
V <sub>O</sub>	Output Voltage	THD+N=1%, V <sub>DD</sub> =3.3V, f=1kHz	2.0	2.3		V <sub>RMS</sub>
THD+N	Total harmonic distortion + noise	V <sub>O</sub> =2V <sub>RMS</sub> , f=1kHz		0.001		%
X <sub>TALK</sub>	Channel crosstalk	V <sub>O</sub> =2V <sub>RMS</sub>		-105		dB
SNR	Signal noise ratio	A-weighted	90	105		dB
DNR	Dynamic range	A-weighted		105		dB
C <sub>L</sub>	Maximum capacitive load			220		pF
V <sub>N</sub>	Noise output voltage	A-weighted		10		μV <sub>RMS</sub>
G <sub>BW</sub>	Unity gain bandwidth			7.2		MHz
A <sub>VO</sub>	Open loop voltage gain			165		dB
V <sub>UVP</sub>	External under-voltage detection			1.25	1.325	V
I <sub>Hys</sub>	External under-voltage detection hysteresis current			6		μA
f <sub>CP</sub>	Charge pump frequency			300		kHz



# DIO2624

2-Vrms Audio Driver with Integrated 4-ch 6<sup>th</sup>-Order SD/HD Video Filter

## Electrical Characteristics for the Video Filter module

Typical value:  $T_A = 25^\circ\text{C}$ ,  $V_{CC}=5\text{V}$ ,  $R_{SOURCE}=37.5\Omega$ ,  $R_L=150\Omega$  loads; all inputs are AC couple with  $0.1\mu\text{F}$ ; all outputs are AC coupled with  $220\mu\text{F}$ ; unless otherwise specified.

Symbol	Parameter	Conditions	Min.	Typ.	Max.	Unit
<b>DC ELECTRICAL CHARACTERISTICS</b>						
$I_{CC}$	Supply Current	HD + SD Channels		78	90	mA
$V_{IN}$	Input Common Mode Voltage Range		GND		1.4	V <sub>pp</sub>
PSRR	Power Supply Rejection			-60	-50	dB
<b>HIGH DEFINITION AC PERFORMANCE</b>						
AV	Channel Gain		5.8	6.0	6.2	dB
BW	Band Width	$\pm 0.5\text{dB}$ , $R_{SOURCE}=75\Omega$		26		MHz
		-1dB, $R_{SOURCE}=75\Omega$		31		
		-3dB, $R_{SOURCE}=75\Omega$		37		
AR	Attenuation	$f=74.25\text{MHz}$ , $R_{SOURCE}=75\Omega$		-33		dB
THD	Output Distortion	$V_{OUT}=1.4\text{V}_{PP}$ , $f=10\text{MHz}$		0.6		%
		$V_{OUT}=1.4\text{V}_{PP}$ , $f=20\text{MHz}$		0.8		
$X_{TALK}$	Crosstalk	$f=1\text{MHz}$ , $V_{IN}=1.4\text{V}_{PP}$		-75		dB
SNR	Signal to Noise Ratio	100kHz to 30MHz, 100% White Signal		65		dB
	Group Delay	100kHz to 30MHz		5		ns
	Propagation Delay	Input to Output		20		ns
SR	Slew Rate	2V Output 80% to 20%		90		V/ $\mu\text{s}$
<b>STANDARD DEFINITION AC PERFORMANCE</b>						
AV	Channel Gain		5.8	6.0	6.2	dB
BW	Bandwidth	-1dB		8.0		MHz
		-3dB		9.0		
AR	Attenuation	$f=27\text{MHz}$		-56		dB
DG	Differential Gain			0.6		%
DP	Differential Phase			1.2		$^\circ$
THD	Output Distortion	$f=4\text{MHz}$		1.5		%
$X_{TALK}$	Crosstalk	$f=1\text{MHz}$		-85		dB
SNR	Signal to Noise Ratio			70		dB
$t_{PD}$	Propagation Delay			80		ns
	Group Delay	$f=400\text{kHz}$ , $6.5\text{MHz}$		10		ns
CLG_SD	Chroma Luma Gain	$f=3.58\text{MHz}$ ref to SD in at 400kHz		100		%
CLD_SD	Chroma Luma Delay	$f=3.58\text{MHz}$ ref to SD in at 400kHz		5.5		ns

Notes:  $\text{SNR}=20 \cdot \log(714\text{mV} / \text{rms noise})$ .

Specifications subject to change without notice.



# DIO2624

2-Vrms Audio Driver with Integrated 4-ch 6<sup>th</sup>-Order SD/HD Video Filter

## Typical Performance Characteristics for the Audio Driver

At  $V_{DD}=3.3V$ ,  $R_L=10k\Omega$ ,  $C_{PUMP}=C_{PVSS}=1\mu F$ ,  $R_{IN}=15k\Omega$ ,  $R_{fb}=30k\Omega$ ,  $T_A = +25^\circ C$ , unless otherwise noted.

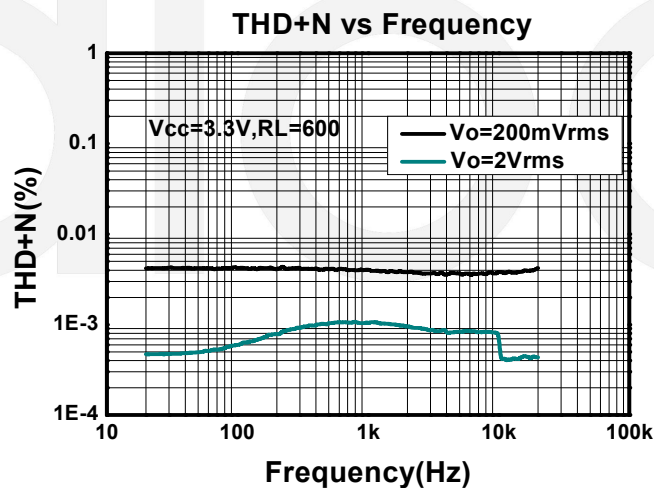
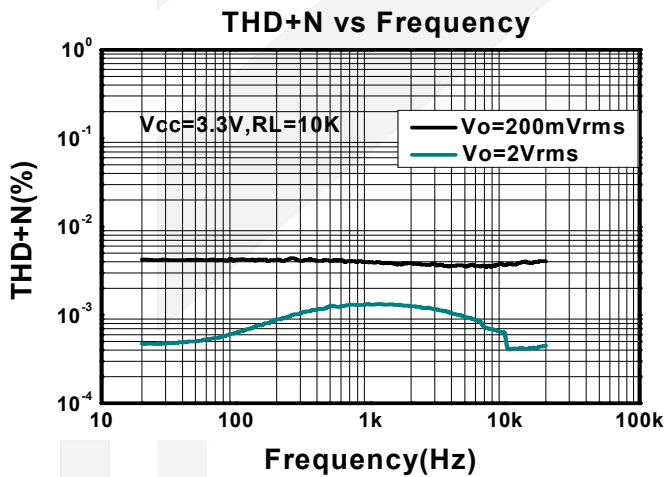
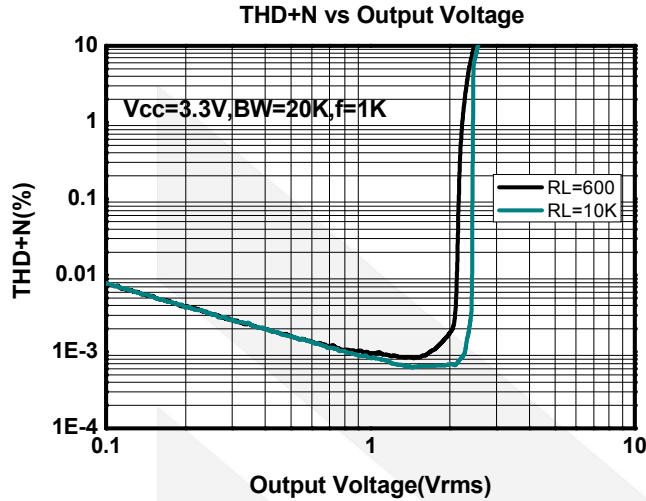

Typical Application

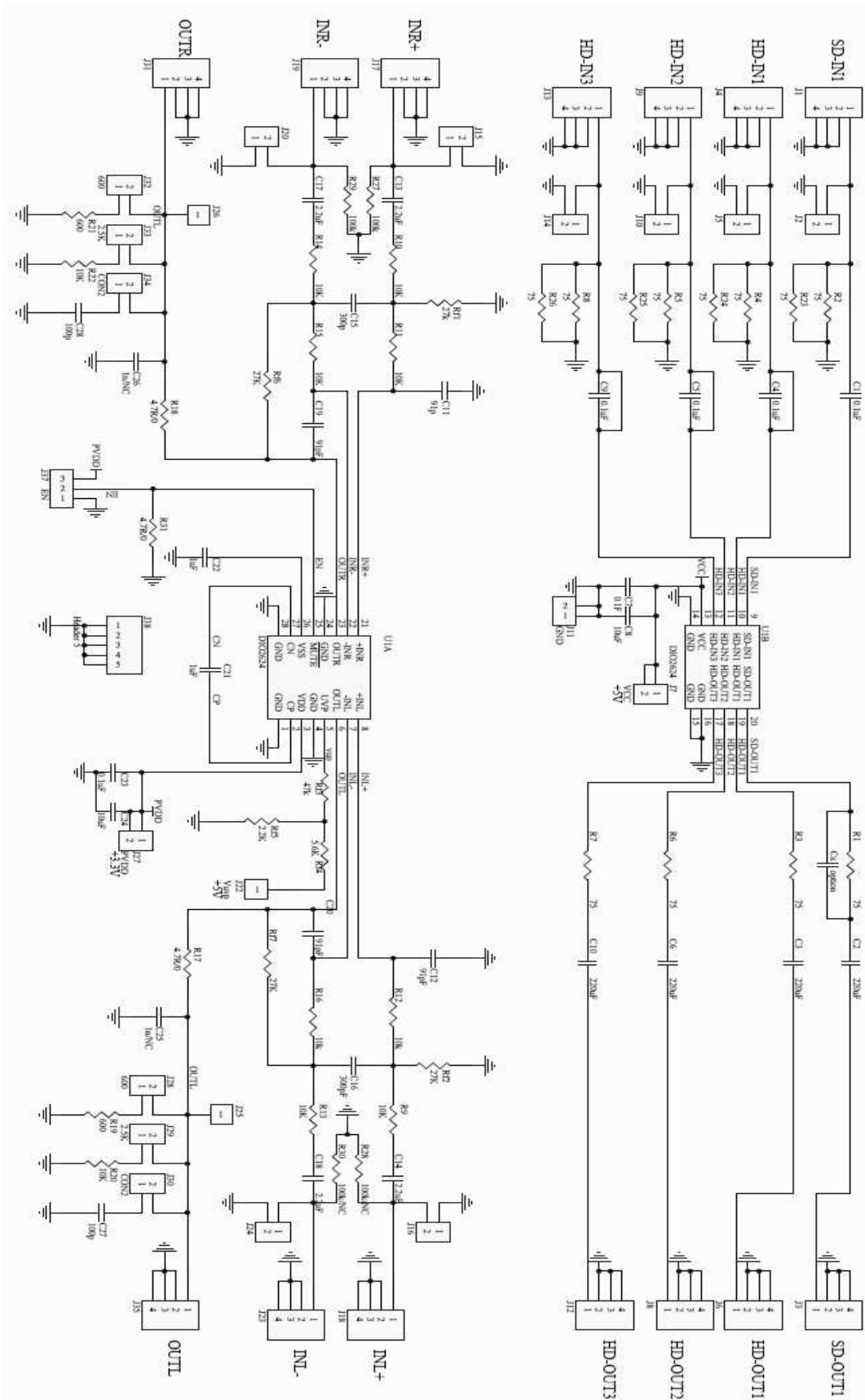

### Application Notes

#### Important Note:

In some applications, if the power supply noise needs to be filtered, the ferrite bead is recommended in a value of 600Ω@100MHz, instead of RC network. RC network normally will lower the power supply resulting in the degraded the audio performance. If the resistor is not chosen properly, which can trigger the internal UVP detection circuit and mute the output. As depicted below.



#### Gain-Setting Resistors Ranges and Input-Blocking Capacitors

The gain-setting resistors,  $R_{IN}$  and  $R_{FB}$ , must be chosen so that noise, stability, and input capacitor size of the Audio Driver are kept within acceptable limits. Voltage gain is defined as  $R_{FB}$  divided by  $R_{IN}$ .

Table 1 lists the recommended resistor value for different gain settings. Selecting values that are too low demands a large input ac-coupling capacitor  $C_{IN}$ . Selecting values that are too high increases the noise of the amplifier.

The gain-setting resistor must be placed close to the input pins to minimize capacitive loading on these input pins and to ensure maximum stability.

**Table 1 Input Capacitor with 2Hz cutoff and Resistor Values Recommended**

Input Res., $R_{IN}$	Feedback Res., $R_{fb}$	Inverting Gain
22 kΩ	22 kΩ	-1 V/V
15 kΩ	30 kΩ	-2 V/V
10 kΩ	100 kΩ	-10 V/V

$$f_{CIN} = \frac{1}{2\pi R_{IN} C_{IN}}, \text{ or}$$

$$C_{IN} = \frac{1}{2\pi R_{IN} f_{CIN}}$$

**Equation 1 Cutoff decision Cutoff**

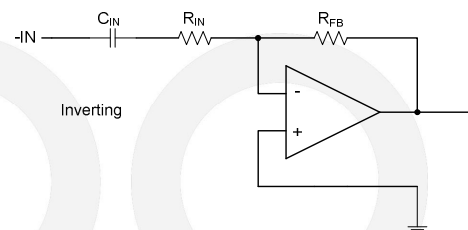

**Figure 2 Inverting Gain Configuration**



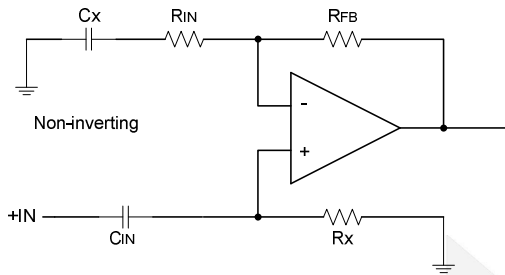

Figure 3 Non-Inverting Gain Configuration

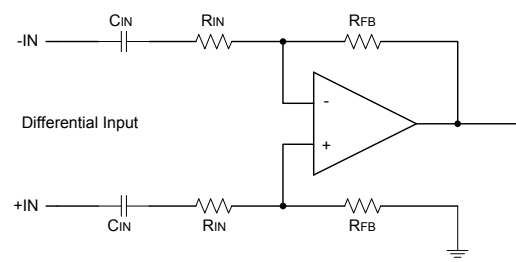

Figure 4 Differential Gain Configuration

### INPUT-BLOCKING CAPACITORS

DC input-blocking capacitors are required to be added in series with the audio signal into the input pins of the Audio Driver. These capacitors block the dc portion of the audio source and allow the Audio Driver inputs to be properly biased to provide maximum performance.

### 2nd Order Filter Typical Application

Several audio DACs used today require an external low-pass filter to remove out-of-band noise. This is possible with the Audio Driver, as it can be used like a standard OPAMP. Several filter topologies can be implemented, both single-ended and differential. In Figure 5, a multi-feedback (MFB) with differential input and single-ended input is shown.

An ac-coupling capacitor to remove dc content from the source is shown; it serves to block any dc content from the source and lowers the dc-gain to 1, helping reducing the output dc-offset to minimum.

The resistor values should have a low value for obtaining low noise, but should also have a high enough value to get a small size ac-coupling capacitor.

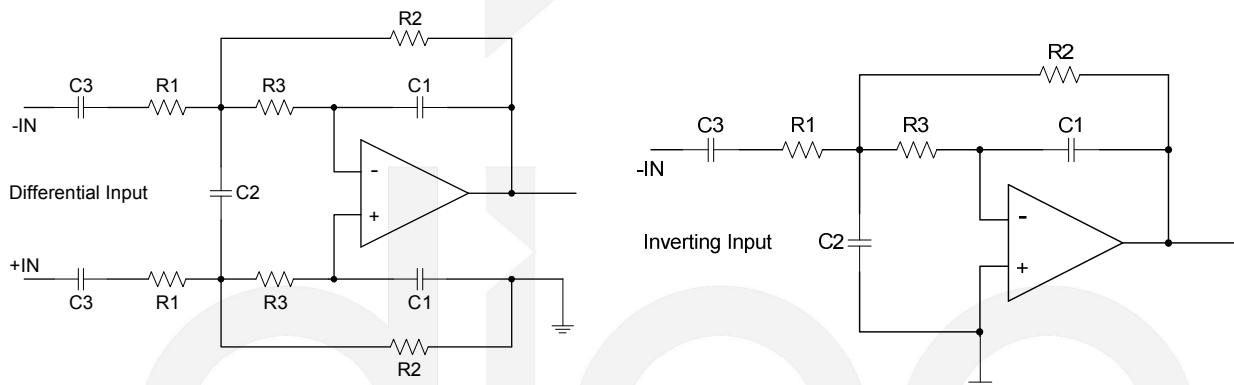

Figure 5 Second-Order Active Low-Pass Filter

### Charge Pump Flying Capacitor and VSS Capacitor

The charge pump flying capacitor serves to transfer charge during the generation of the negative supply voltage. The VSS capacitor must be at least equal to the charge pump capacitor in order to allow maximum charge transfer. Low-ESR capacitors are an ideal selection, and a value of 1μF is typical. Capacitor values that are smaller than 1μF can be used, but the maximum output voltage may be reduced and the device may not operate to specifications.

### Decoupling Capacitors

The Audio Driver requires adequate power supply decoupling to ensure that the noise and total harmonic distortion (THD) are low. A good low equivalent-series-resistance (ESR) ceramic capacitor, typically 1µF, placed as close as possible to the device VDD lead works best. Placing this decoupling capacitor close to the Audio Driver is important for the performance of the amplifier. For filtering lower-frequency noise signals, a 10µF or greater capacitor placed near the audio power amplifier would also help, but it is not required in most applications because of the high PSRR of this device.

### Pop-Free Power-Up

Pop-free power up is ensured by keeping the  $\overline{\text{Mute}}$  (shutdown pin) low during power-supply ramp up and ramp down. The  $\overline{\text{Mute}}$  pin should be kept low until the input ac-coupling capacitors are fully charged before asserting the Mute pin high to achieve pop-less power up. Figure 6 illustrates the preferred sequence.

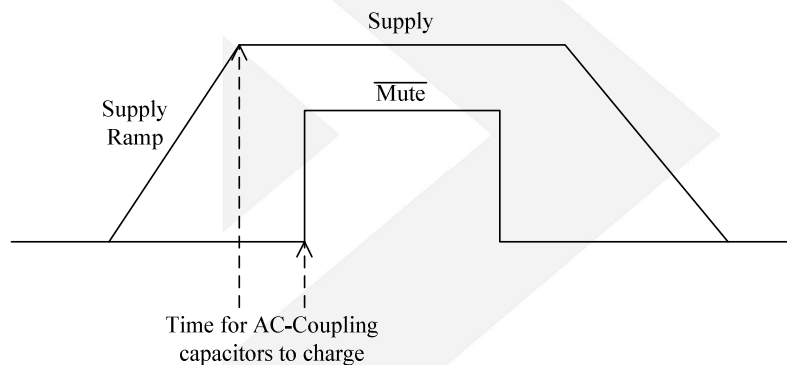

Figure 6 Power-Up Sequences

### External Under-voltage Detection

External under-voltage detection can be used to mute/shut down the DIO2624 before an input device can generate a pop. Although the shutdown voltage is 1.25V typically, customers need to consider the accuracy of system passive components such as resistors and associated temperature variation. In order to guarantee the power-on of the device, usually greater than 1.325V at UVP pin is recommended to cover the possible uncertainty. Users often select a resistor divider to obtain the power-on and shutdown threshold for the specific application. The typical thresholds can be calculated as follows, respectively for VSUP\_MO at 5V and 12V. Usually for best power down noise performance, 12V supply is recommended for UVP circuitry as below. Typically this 12V is the power supply which generates the 5V supply for DIO2624 VDD pins.

Case 1: VSUP\_MO= 12V (**Recommended**)

$$V_{\text{UVP}} = (1.25\text{V} - 6\mu\text{A} \cdot R_{13}) \cdot (R_{11} + R_{12}) / R_{12};$$

$$V_{\text{hysteresis}} = 5\mu\text{A} \cdot R_{13} \cdot (R_{11} + R_{12}) / R_{12};$$

With the condition  $R_{13} \gg R_{11} // R_{12}$ .

For example, if  $R_{11} = 11\text{k}$ ,  $R_{12} = 1.4\text{k}$  and  $R_{13} = 47\text{k}$ ,

Then  $V_{\text{UVP}} = 8.574\text{V}$ ;  $V_{\text{hysteresis}} = 2.081\text{V}$

Here,  $V_{\text{UVP}}$  is the shutdown threshold.

In this case, the voltage at UVP pin is greater than 1.325V under worst case of VSUP\_MO ripples.

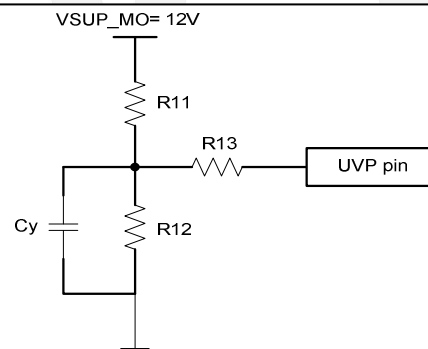



## DIO2624

Case 2: VSUP\_MO= 5.0V

$$V_{UVP}=(1.25V-6\mu A \cdot R_{13}) \cdot (R_{11}+R_{12})/R_{12};$$

$$V_{hysteresis}=5\mu A \cdot R_{13} \cdot (R_{11}+R_{12})/R_{12};$$

With the condition  $R_{13} \gg R_{11}/R_{12}$ .

For example, if  $R_{11}=5.6k$ ,  $R_{12}=2.43k$  and  $R_{13}=15k$ ,

Then  $V_{UVP}=3.83V$ ;  $V_{hysteresis}=0.247V$

Here,  $V_{UVP}$  is the shutdown threshold.

In this case, the voltage at UVP pin is greater than 1.325V under worst case of VSUP\_MO ripples.

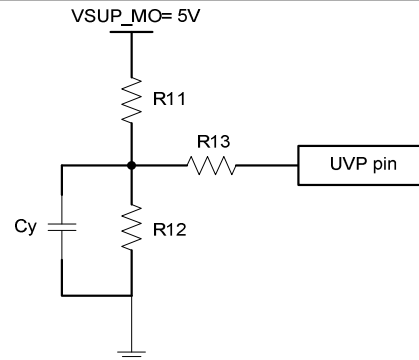

To minimize the system power-up and power-down threshold variations, resistors with less than 1% variations are recommended. Although some resistor value options are offered above for customer's reference or starting points, customers should always verify those resistor options in their actual design. Customer can adjust their own design to achieving the best performance between pop noise and power-on threshold by adjusting the passive resistors R11, R12 and R13.

### Capacitive Load

The Audio Driver has the ability to drive a high capacitive load up to 220pF directly. Higher capacitive loads can be accepted by adding a series resistor of 47Ω or larger.

For further assistance, please contact DIOO worldwide sales office to seek technical support. You can find DIOO sales office information at [www.dioo.com](http://www.dioo.com).





# DIO2624

2-Vrms Audio Driver with Integrated 4-ch 6<sup>th</sup>-Order SD/HD Video Filter

## Physical Dimensions: EP-TSSOP-28

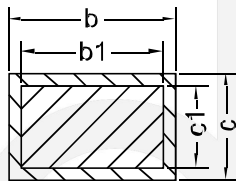
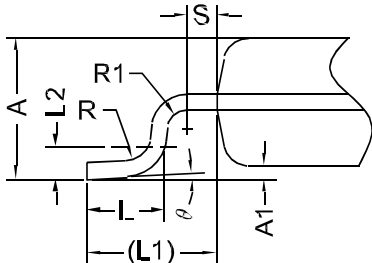
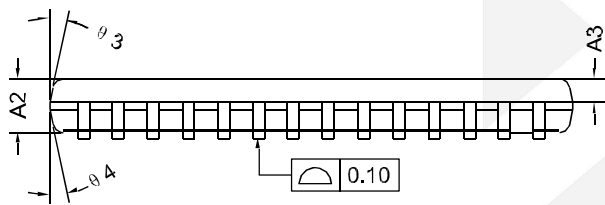
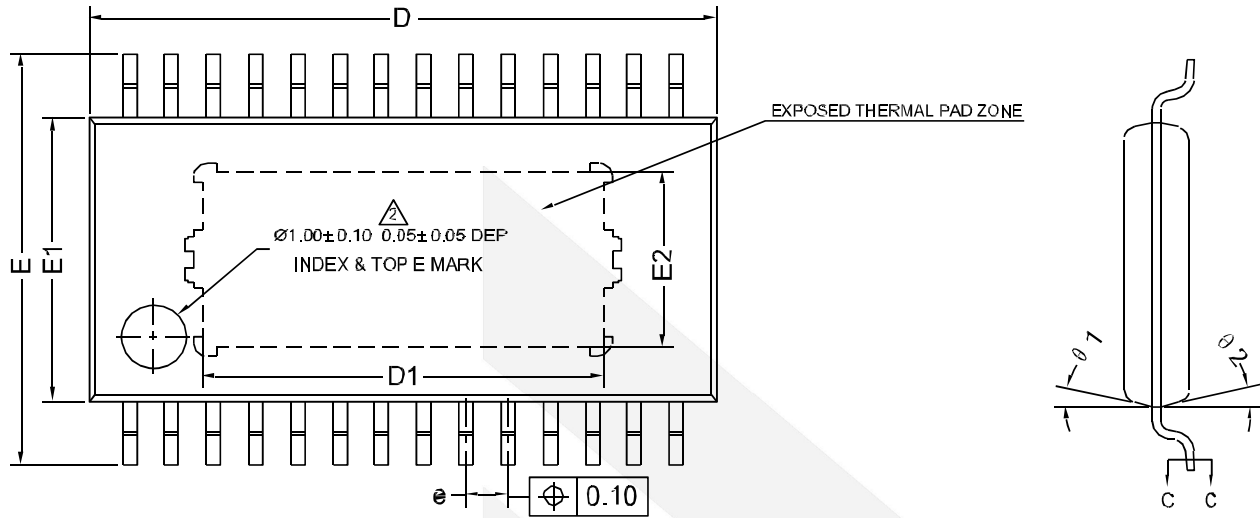

SECTION C-C  
NORMAL PLATING

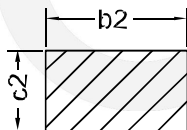

SECTION C-C  
NiPdAu PLATING

COMMON DIMENSIONS (UNITS OF MEASURE=MILLIMETER)			
Symbol	MIN	NOM	MAX
A	-	-	1.20
A1	0.05	-	0.15
A2	0.90	1.00	1.10
A3	0.34	0.44	0.54
b	0.20	-	0.29
b1	0.19	0.22	0.25
b2	0.19	-	0.25
c	0.13	-	0.18
c1	0.12	0.13	0.14
C2	0.12	-	0.14
D	9.60	9.70	9.80
D1	6.20REF		
E	6.20	6.40	6.60
E1	4.30	4.40	4.50
E2	2.75REF		
e	0.55	0.65	0.75
L	0.45	0.60	0.75
L1	1.00REF		
L2	0.25BSC		
R	0.09	-	-
R1	0.09	-	-
S	0.20	-	-
θ	0°	-	8°
θ1	10°	12°	14°
θ2	10°	12°	14°
θ3	10°	12°	14°
θ4	10°	12°	14°



# DIO2624

2-Vrms Audio Driver with Integrated 4-ch 6<sup>th</sup>-Order SD/HD Video Filter

## Physical Dimensions: TSSOP-24

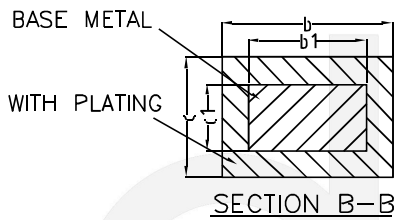
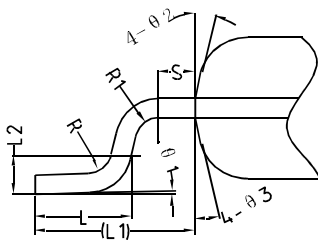
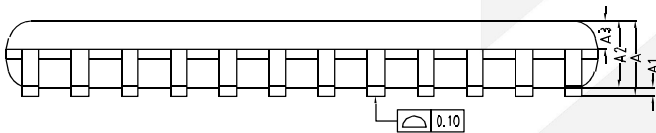
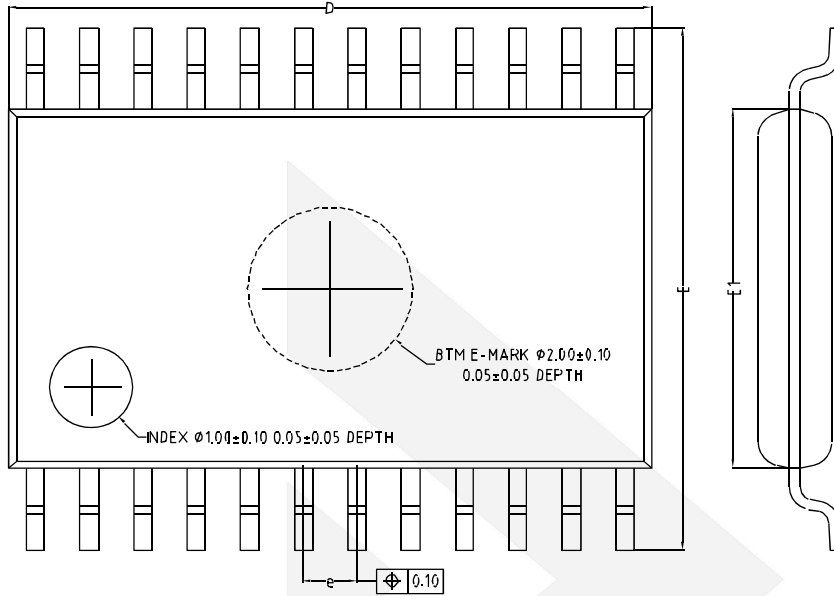

COMMON DIMENSIONS (UNITS OF MEASURE=MILLIMETER)			
Symbol	MIN	NOM	MAX
A	-	-	1.20
A1	0.05	-	0.15
A2	0.80	0.90	1.00
A3	0.34	0.39	0.44
b	0.20	-	0.29
b1	0.19	0.22	0.25
c	0.10	-	0.19
c1	0.10	0.13	0.15
D	7.70	7.80	7.90
E	6.20	6.40	6.60
E1	4.30	4.40	4.50
e	0.55	0.65	0.75
L	0.45	0.60	0.75
L1	1.00REF		
L2	0.25BSC		
R	0.09	-	-
R1	0.09	-	-
S	0.20	-	-
Ø1	0°	-	8°
Ø2	12°	14°	16°
Ø3	12°	14°	16°



## DIO2624

2-Vrms Audio Driver with Integrated 4-ch 6<sup>th</sup>-Order SD/HD Video Filter

### CONTACT US

Dioo is a professional design and sales corporation for high-quality and performance analog semiconductors. The company focuses on industry markets, such as, cell phone, handheld products, laptop, and medical equipment and so on. Dioo's product families include analog signal processing and amplifying, LED drivers and charger IC. Go to <http://www.dioo.com> for a complete list of Dioo product families.

For additional product information, or full datasheet, please contact with our Sales Department or Representatives.

dioo



## Стандарт Электрон Связь

Мы молодая и активно развивающаяся компания в области поставок электронных компонентов. Мы поставляем электронные компоненты отечественного и импортного производства напрямую от производителей и с крупнейших складов мира.

Благодаря сотрудничеству с мировыми поставщиками мы осуществляем комплексные и плановые поставки широчайшего спектра электронных компонентов.

Собственная эффективная логистика и склад в обеспечивает надежную поставку продукции в точно указанные сроки по всей России.

Мы осуществляем техническую поддержку нашим клиентам и предпродажную проверку качества продукции. На все поставляемые продукты мы предоставляем гарантию .

Осуществляем поставки продукции под контролем ВП МО РФ на предприятия военно-промышленного комплекса России , а также работаем в рамках 275 ФЗ с открытием отдельных счетов в уполномоченном банке. Система менеджмента качества компании соответствует требованиям ГОСТ ISO 9001.

Минимальные сроки поставки, гибкие цены, неограниченный ассортимент и индивидуальный подход к клиентам являются основой для выстраивания долгосрочного и эффективного сотрудничества с предприятиями радиоэлектронной промышленности, предприятиями ВПК и научно-исследовательскими институтами России.

С нами вы становитесь еще успешнее!

### Наши контакты:

**Телефон:** +7 812 627 14 35

**Электронная почта:** [sales@st-electron.ru](mailto:sales@st-electron.ru)

**Адрес:** 198099, Санкт-Петербург,  
Промышленная ул, дом № 19, литера Н,  
помещение 100-Н Офис 331