

20-Bit, 2-Port Bus Switch

Features

- Near-Zero propagation delay
- 5-ohm switches connect inputs to outputs
- Direct bus connection when switches are ON
- 32X384 function with flow through pinout make board layout easier
- Ultra-low quiescent power (0.5μW typical)
 - Ideally suited for notebook applications
- Industrial operating temperature: -40°C to +85°C
- Packaging (Pb-free & Green):
 - 48-pin 240-mil wide plastic TSSOP (A)

Block Diagram

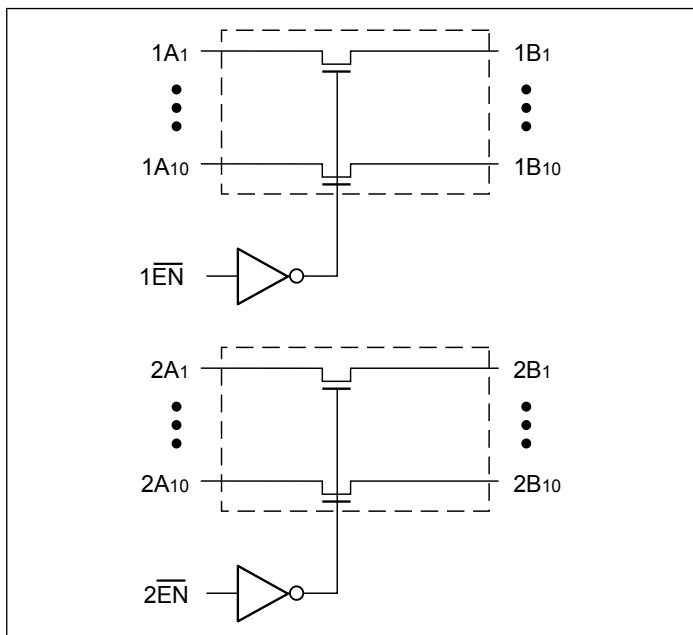

Description

The PI5C16210 is configured as 20-bit, 2-port bus switches designed with a low ON resistance (5-ohm) allowing inputs to be connected directly to outputs. The bus switch creates no additional propagational delay or additional ground bounce noise. The switches are turned ON by the Bus Enable (\overline{xOE}) input signal.

Pin Configuration

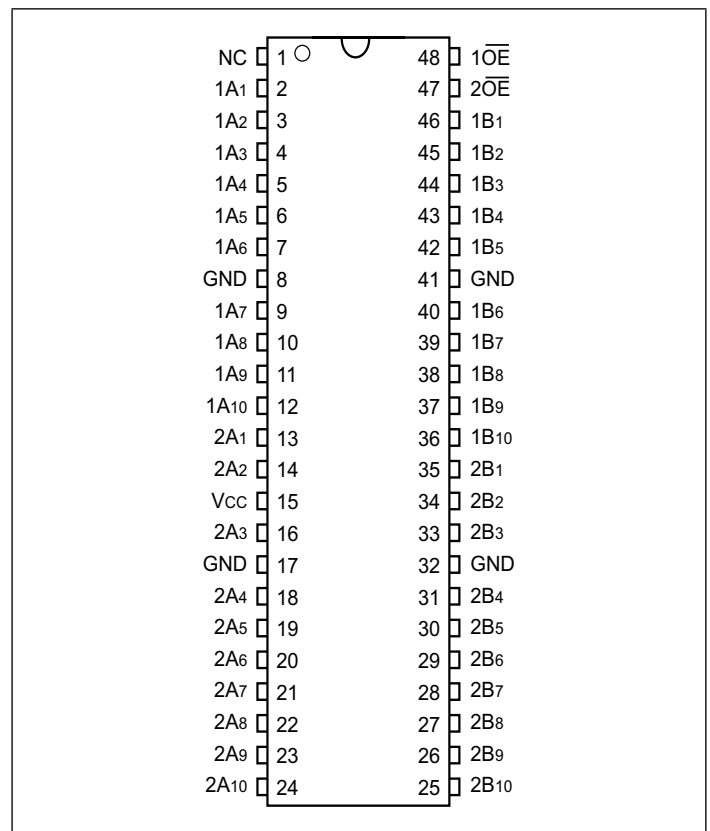

Truth Table⁽¹⁾

| Inputs | | Inputs/Outputs | |
|------------------|------------------|----------------|---------|
| $\overline{1OE}$ | $\overline{2OE}$ | 1A,1B | 2A,2B |
| L | L | 1A = 1B | 2A = 2B |
| L | H | 1A = 1B | Z |
| H | L | Z | 2A = 2B |
| H | H | Z | Z |

Note: 1. H = High Voltage Level
L = Low Voltage Level
Hi-Z = High Impedance

Pin Description

| Pin Name | Description |
|-------------------------------------|-------------------------------|
| $\overline{1OE}$, $\overline{2OE}$ | Bus Enable Input (Active LOW) |
| 1A1-1A10, 2A1-2A10 | Bus A |
| 1B1 - 1B10, 2B1 - 2B10 | Bus B |

Absolute Maximum Ratings

| Parameter | Min. | Max. | Units |
|--|------|------|-------|
| Storage Temperature | -65 | 150 | °C |
| Ambient Temperature with Power Applied | -40 | 85 | °C |
| Supply Voltage to Ground Potential (Inputs & V _{CC} Only) | -0.5 | 7.0 | V |
| Supply Voltage to Ground Potential (Outputs & D/O Only) | -0.5 | 7.0 | V |
| DC Input Voltage | -0.5 | 7.0 | V |
| DC Output Current | - | 120 | mA |
| Power Dissipation | - | 0.5 | W |

Stress beyond those listed under “Absolute Maximum Ratings” may cause permanent damage to the device.

DC Electrical Characteristics (Over the Operating Range, T_A = -40°C to +85°C, V_{CC} = 4 to 5.5V)

| Parameters | Description | Test Conditions ⁽¹⁾ | Min | Typ ⁽²⁾ | Max | Units |
|------------------|--------------------------------------|--|------|--------------------|------|-------|
| V _{IH} | Input HIGH Voltage | Guaranteed Logic HIGH Level | 2.0 | | | V |
| V _{IL} | Input LOW Voltage | Guaranteed Logic LOW Level | -0.5 | | 0.8 | V |
| I _I | Input Current | V _{CC} = 5.5V, V _{IN} = 5.5V OR GND | ±1 | | | μA |
| | | V _{CC} = 0., V _{IN} = V _{CC} | | | ±1 | μA |
| I _{OZH} | High Impedance Output Current | 0 ≤ A, B ≤ V _{CC} | | | 10 | μA |
| V _{IK} | Clamp Diode Voltage | V _{CC} = 4.5V, I _{IN} = -18mA | | -0.7 | -1.2 | V |
| I _{OS} | Short Circuit Current ⁽³⁾ | A (B) = 0V, B (A) = V _{CC} | 100 | | | mA |
| V _H | Input Hysteresis at Control Pins | | | 150 | | mV |
| R _{ON} | Switch On Resistance ⁽⁴⁾ | V _{CC} = 4.5V, V _{IN} = 0.0V, I _{ON} = 30 mA, 64 mA | | 5 | 7 | Ω |
| | | V _{CC} = 4.5V, V _{IN} = 2.4V, I _{ON} = 15 mA | | | 15 | |
| | | V _{CC} = 4 V, V _{IN} = 2.4V, I _{ON} = 15 mA | | 14 | 20 | |

Notes:

- For Max. or Min. conditions, use appropriate value specified under Electrical Characteristics for the applicable device type.
- Typical values are at V_{CC} = 5.0V, T_A = 25°C ambient and maximum loading.
- Not more than one output should be shorted at one time. Duration of the test should not exceed one second.
- Measured by the voltage drop between A and B pin at indicated current through the switch. ON resistance is determined by the lower of the voltages on the two (A,B) pins.

Capacitance (T_A = 25°C, f = 1 MHz)

| Parameters ⁽¹⁾ | Description | Test Conditions | Typ | Units |
|---------------------------|-----------------------------|----------------------------|-----|-------|
| C _{IN} | Input Capacitance | V _{IN} = 0V or 3V | 2.4 | pF |
| C _{OFF} | A/B Capacitance, Switch Off | V _{IN} = 0V or 3V | 3.4 | pF |

Notes:

- This parameter is determined by device characterization but is not production tested.

Power Supply Characteristics

| Parameters | Description | Test Conditions ⁽¹⁾ | | Min | Typ ⁽²⁾ | Max | Units |
|------------------|---|---|--|-----|--------------------|------|------------|
| I _{CC} | Quiescent Power Supply Current | V _{CC} = Max. | V _{IN} = GND or V _{CC} | | 0.1 | 10 | μA |
| ΔI _{CC} | Supply Current per Input HIGH | V _{CC} = Max. | V _{IN} = 3.4V ⁽³⁾ | | | 2.5 | mA |
| I _{CCD} | Supply Current per Input per MHz ⁽⁴⁾ | V _{CC} = Max. A and B Pins Open Control Input Toggling 50% Duty Cycle | | | | 0.25 | mA/ MHz |

Notes:

1. For Max. or Min. conditions, use appropriate value specified under Electrical Characteristics for the applicable device.
2. Typical values are at V_{CC} = 5.0V, +25°C ambient.
3. Per TTL driven input (V_{IN} = 3.4V, control inputs only); A and B pins do not contribute to I_{CC}.
4. This current applies to the control inputs only and represent the current required to switch internal capacitance at the specified frequency. The A and B inputs generate no significant AC or DC currents as they transition. This parameter is not tested, but is guaranteed by design.

Switching Characteristics over Operating Range

| Parameters | Description | Test Conditions | V _{CC} = 5V ±0.5V | | V _{CC} = 4V | | Units |
|--------------------------------------|--|---|----------------------------|------|----------------------|------|-------|
| | | | Min | Max | Min | Max | |
| t _{PLH} t _{PHL} | Propagation Delay ^(1,2) Ax to Bx, Bx to Ax | C _L = 50 pF R _L = 500Ω | | 0.25 | | 0.25 | ns |
| t _{PZH} t _{PZL} | Bus Enable Time x $\overline{\text{OE}}$ to Ax or Bx | | 1.5 | 6.5 | | 6.3 | |
| t _{PHZ} t _{PLZ} | Bus Disable Time x $\overline{\text{OE}}$ to Ax or Bx | | 1.5 | 5.5 | | 5.5 | |

Notes:

1. This parameter is guaranteed but not tested on Propagation Delays.
2. The bus switch contributes no propagational delay other than the RC delay of the On-Resistance of the switch and the load capacitance. The time constant for the switch alone is of the order of 0.25 ns for 50 pF load. Since this time constant is much smaller than the rise/fall times of typical driving signals, it adds very little propagational delay to the system. Propagational delay of the bus switch when used in a system is determined by the driving circuit on the driving side of the switch and its interaction with the load on the driven side.

Packaging Mechanical: 48-pin TSSOP (A48)

DOCUMENT CONTROL NO.
PD - 1501

REVISION: G
DATE: 03/09/05

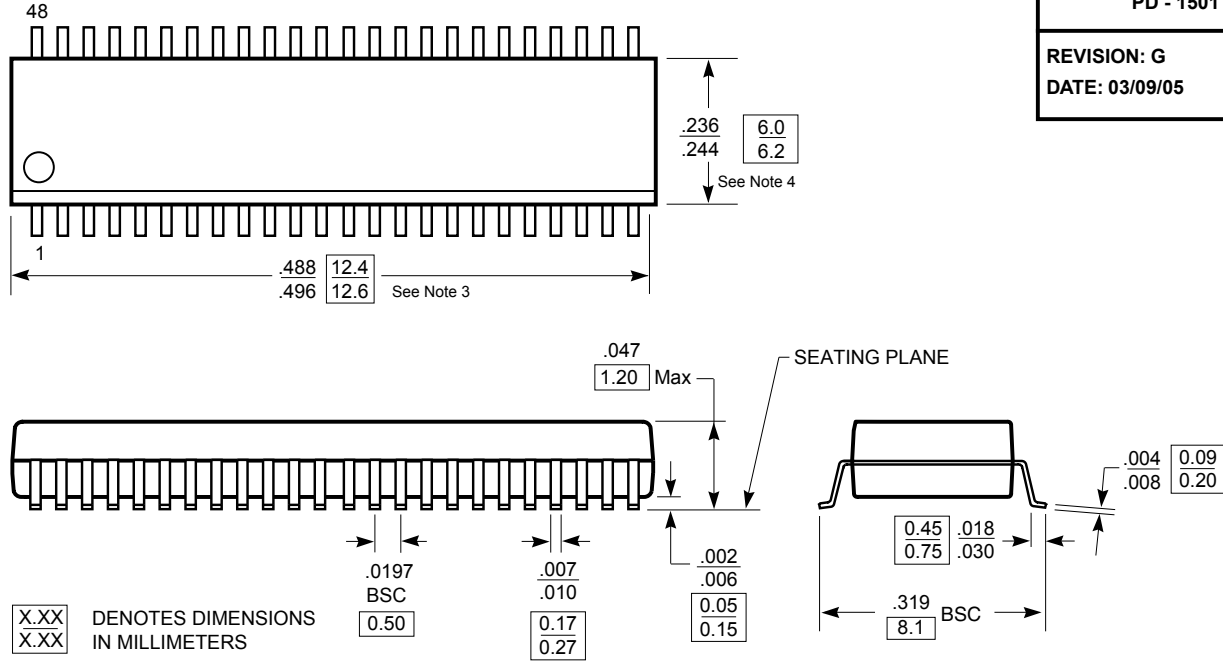

Note:

1. Controlling dimensions in millimeters.
2. Ref: JEDEC MO-153F/ED
3. Dimension does not include mold flash, protrusions or gate burrs. Mold flash, protrusions and gate burrs shall not exceed 0.15mm per side.
4. Dimension does not include interlead flash or protrusion. Interlead flash or protrusion shall not exceed 0.25mm per side.



Pericom Semiconductor Corporation
3545 N. 1st Street, San Jose, CA 95134
1-800-435-2335 • www.pericom.com

DESCRIPTION: 48-Pin 240-Mil Wide TSSOP

PACKAGE CODE: A

Ordering Information

| Ordering Code | Package Code | Package Type |
|---------------|--------------|--|
| PI5C16210AE | A | Pb-free and Green, 48-pin 240-mil wide plastic TSSOP |

1. Thermal characteristics can be found on the company web site at www.pericom.com/packaging/

Mouser Electronics

Authorized Distributor

Click to View Pricing, Inventory, Delivery & Lifecycle Information:

[Diodes Incorporated:](#)

[PI5C3301CEX](#) [PI3CH400ZBEX](#)



Стандарт Электрон Связь

Мы молодая и активно развивающаяся компания в области поставок электронных компонентов. Мы поставляем электронные компоненты отечественного и импортного производства напрямую от производителей и с крупнейших складов мира.

Благодаря сотрудничеству с мировыми поставщиками мы осуществляем комплексные и плановые поставки широчайшего спектра электронных компонентов.

Собственная эффективная логистика и склад в обеспечивает надежную поставку продукции в точно указанные сроки по всей России.

Мы осуществляем техническую поддержку нашим клиентам и предпродажную проверку качества продукции. На все поставляемые продукты мы предоставляем гарантию .

Осуществляем поставки продукции под контролем ВП МО РФ на предприятия военно-промышленного комплекса России , а также работаем в рамках 275 ФЗ с открытием отдельных счетов в уполномоченном банке. Система менеджмента качества компании соответствует требованиям ГОСТ ISO 9001.

Минимальные сроки поставки, гибкие цены, неограниченный ассортимент и индивидуальный подход к клиентам являются основой для выстраивания долгосрочного и эффективного сотрудничества с предприятиями радиоэлектронной промышленности, предприятиями ВПК и научно-исследовательскими институтами России.

С нами вы становитесь еще успешнее!

Наши контакты:

Телефон: +7 812 627 14 35

Электронная почта: sales@st-electron.ru

Адрес: 198099, Санкт-Петербург,
Промышленная ул, дом № 19, литера Н,
помещение 100-Н Офис 331