

**CoolMOS™ Power Transistor**
**Features**

- Lowest figure of merit  $R_{ON} \times Q_g$
- Ultra low gate charge
- Extreme dv/dt rated
- High peak current capability
- Pb-free lead plating; RoHS compliant; Halogen free for mold compound
- Qualified for industrial grade applications according to JEDEC<sup>0)</sup>

**Product Summary**

|                     |       |          |
|---------------------|-------|----------|
| $V_{DS} @ T_{jmax}$ | 550   | V        |
| $R_{DS(on),max}$    | 0.250 | $\Omega$ |
| $Q_{g,typ}$         | 27    | nC       |

**CoolMOS CP is designed for:**

- Hard- & Softswitching SMPS topologies
- CCM PFC for ATX, Notebookadapter, PDP and LCD TV
- PWM for ATX, Notebookadapter, PDP and LCD TV

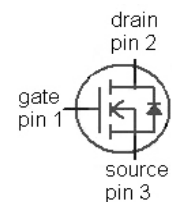
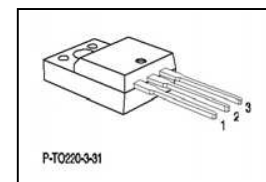
**TO220 FP**

| Type        | Package    | Marking |
|-------------|------------|---------|
| IPA50R250CP | PG-TO220FP | 5R250P  |

**Maximum ratings, at  $T_j=25\text{ °C}$ , unless otherwise specified**

| Parameter   | Symbol         | Conditions                                | Value       | Unit               |
|---|----------------|---|-------------|--------------------|
| Continuous drain current <sup>1)</sup>                  | $I_D$          | $T_C=25\text{ °C}$                        | 13          | A                  |
|   |                | $T_C=100\text{ °C}$                       | 9           |                    |
| Pulsed drain current <sup>2)</sup>                      | $I_{D,pulse}$  | $T_C=25\text{ °C}$                        | 31          |                    |
| Avalanche energy, single pulse                          | $E_{AS}$       | $I_D=5.2\text{ A}$ , $V_{DD}=50\text{ V}$ | 345         | mJ                 |
| Avalanche energy, repetitive $t_{AR}$ <sup>2),3)</sup>  | $E_{AR}$       | $I_D=5.2\text{ A}$ , $V_{DD}=50\text{ V}$ | 0.52        |                    |
| Avalanche current, repetitive $t_{AR}$ <sup>2),3)</sup> | $I_{AR}$       |   | 5.2         | A                  |
| MOSFET dv/dt ruggedness                                 | dv/dt          | $V_{DS}=0\text{...}400\text{ V}$          | 50          | V/ns               |
| Gate source voltage                                     | $V_{GS}$       | static                                    | $\pm 20$    | V                  |
|   |                | AC (f>1 Hz)                               | $\pm 30$    |                    |
| Power dissipation                                       | $P_{tot}$      | $T_C=25\text{ °C}$                        | 33          | W                  |
| Operating and storage temperature                       | $T_j, T_{stg}$ |   | -55 ... 150 | $^{\circ}\text{C}$ |
| Mounting torque   |                | M2.5 screws                               | 60          | Ncm                |

**Maximum ratings, at  $T_j=25\text{ °C}$ , unless otherwise specified**

| Parameter                                      | Symbol        | Conditions         | Value | Unit |
|--|---------------|--------------------|-------|------|
| Continuous diode forward current <sup>1)</sup> | $I_S$         | $T_C=25\text{ °C}$ | 7.8   | A    |
| Diode pulse current <sup>2)</sup>              | $I_{S,pulse}$ |                    | 31    |      |
| Reverse diode $dv/dt$ <sup>4)</sup>            | $dv/dt$       |                    | 15    | V/ns |

| Parameter | Symbol | Conditions | Values |      |      | Unit |
|-----------|--------|------------|--------|------|------|------|
|           |        |            | min.   | typ. | max. |      |

**Thermal characteristics**

|  |            |                                       |   |   |      |     |
|--|------------|---------------------------------------|---|---|------|-----|
| Thermal resistance, junction - case                        | $R_{thJC}$ |                                       | - | - | 3.75 | K/W |
| Thermal resistance, junction - ambient                     | $R_{thJA}$ | leaded                                | - | - | 62   |     |
| Soldering temperature, wavesoldering only allowed at leads | $T_{sold}$ | 1.6 mm (0.063 in.) from case for 10 s | - | - | 260  | °C  |

**Electrical characteristics, at  $T_j=25\text{ °C}$ , unless otherwise specified**
**Static characteristics**

|                                  |               |   |     |      |      |               |
|----------------------------------|---------------|---|-----|------|------|---------------|
| Drain-source breakdown voltage   | $V_{(BR)DSS}$ | $V_{GS}=0\text{ V}, I_D=250\text{ }\mu\text{A}$             | 500 | -    | -    | V             |
| Gate threshold voltage           | $V_{GS(th)}$  | $V_{DS}=V_{GS}, I_D=0.52\text{ mA}$                         | 2.5 | 3    | 3.5  |               |
| Zero gate voltage drain current  | $I_{DSS}$     | $V_{DS}=500\text{ V}, V_{GS}=0\text{ V}, T_j=25\text{ °C}$  | -   | -    | 1    | $\mu\text{A}$ |
|                                  |               | $V_{DS}=500\text{ V}, V_{GS}=0\text{ V}, T_j=150\text{ °C}$ | -   | 10   | -    |               |
| Gate-source leakage current      | $I_{GSS}$     | $V_{GS}=20\text{ V}, V_{DS}=0\text{ V}$                     | -   | -    | 100  | nA            |
| Drain-source on-state resistance | $R_{DS(on)}$  | $V_{GS}=10\text{ V}, I_D=7.8\text{ A}, T_j=25\text{ °C}$    | -   | 0.22 | 0.25 | $\Omega$      |
|                                  |               | $V_{GS}=10\text{ V}, I_D=7.8\text{ A}, T_j=150\text{ °C}$   | -   | 0.54 | -    |               |
| Gate resistance                  | $R_G$         | $f=1\text{ MHz}, \text{open drain}$                         | -   | 2.2  | -    | $\Omega$      |

| Parameter | Symbol | Conditions | Values |      |      | Unit |
|-----------|--------|------------|--------|------|------|------|
|           |        |            | min.   | typ. | max. |      |

**Dynamic characteristics**

|  |              |   |   |      |   |    |
|--|--------------|---|---|------|---|----|
| Input capacitance  | $C_{iss}$    | $V_{GS}=0\text{ V}, V_{DS}=100\text{ V},$<br>$f=1\text{ MHz}$                           | - | 1420 | - | pF |
| Output capacitance   | $C_{oss}$    |   | - | 63   | - |    |
| Effective output capacitance, energy related <sup>5)</sup> | $C_{o(er)}$  | $V_{GS}=0\text{ V}, V_{DS}=0\text{ V}$<br>to 400 V                                      | - | 60   | - |    |
| Effective output capacitance, time related <sup>6)</sup>   | $C_{o(tr)}$  |   | - | 130  | - |    |
| Turn-on delay time   | $t_{d(on)}$  | $V_{DD}=400\text{ V},$<br>$V_{GS}=10\text{ V}, I_D=7.8\text{ A},$<br>$R_G=23.1\ \Omega$ | - | 35   | - | ns |
| Rise time  | $t_r$        |   | - | 14   | - |    |
| Turn-off delay time  | $t_{d(off)}$ |   | - | 80   | - |    |
| Fall time  | $t_f$        |   | - | 11.0 | - |    |

**Gate Charge Characteristics**

|                       |               |  |   |     |    |    |
|-----------------------|---------------|--|---|-----|----|----|
| Gate to source charge | $Q_{gs}$      | $V_{DD}=400\text{ V}, I_D=7.8\text{ A},$<br>$V_{GS}=0\text{ to }10\text{ V}$ | - | 6   | -  | nC |
| Gate to drain charge  | $Q_{gd}$      |  | - | 9   | -  |    |
| Gate charge total     | $Q_g$         |  | - | 27  | 36 |    |
| Gate plateau voltage  | $V_{plateau}$ |  | - | 5.2 | -  | V  |

**Reverse Diode**

|                               |           |  |   |     |     |               |
|-------------------------------|-----------|--|---|-----|-----|---------------|
| Diode forward voltage         | $V_{SD}$  | $V_{GS}=0\text{ V}, I_F=7.8\text{ A},$<br>$T_j=25\text{ }^\circ\text{C}$ | - | 0.9 | 1.2 | V             |
| Reverse recovery time         | $t_{rr}$  | $V_R=400\text{ V}, I_F=I_S,$<br>$di_F/dt=100\text{ A}/\mu\text{s}$       | - | 300 | -   | ns            |
| Reverse recovery charge       | $Q_{rr}$  |  | - | 3.1 | -   | $\mu\text{C}$ |
| Peak reverse recovery current | $I_{rrm}$ |  | - | 23  | -   | A             |

<sup>0)</sup> J-STD20 and JESD22

<sup>1)</sup> Limited only by  $T_{j,max}$ 
<sup>2)</sup> Pulse width  $t_p$  limited by  $T_{j,max}$ 
<sup>3)</sup> Repetitive avalanche causes additional power losses that can be calculated as  $P_{AV}=E_{AR} \cdot f$ .

<sup>4)</sup>  $I_{SD} \leq I_D, di/dt \leq 200\text{ A}/\mu\text{s}, V_{DClink}=400\text{ V}, V_{peak} < V_{(BR)DSS}, T_j < T_{j,max}$ , identical low and high side switch

<sup>5)</sup>  $C_{o(er)}$  is a fixed capacitance that gives the same stored energy as  $C_{oss}$  while  $V_{DS}$  is rising from 0 to 80%  $V_{DSS}$ .

<sup>6)</sup>  $C_{o(tr)}$  is a fixed capacitance that gives the same charging time as  $C_{oss}$  while  $V_{DS}$  is rising from 0 to 80%  $V_{DSS}$ .

**1 Power dissipation**

$P_{tot}=f(T_c)$

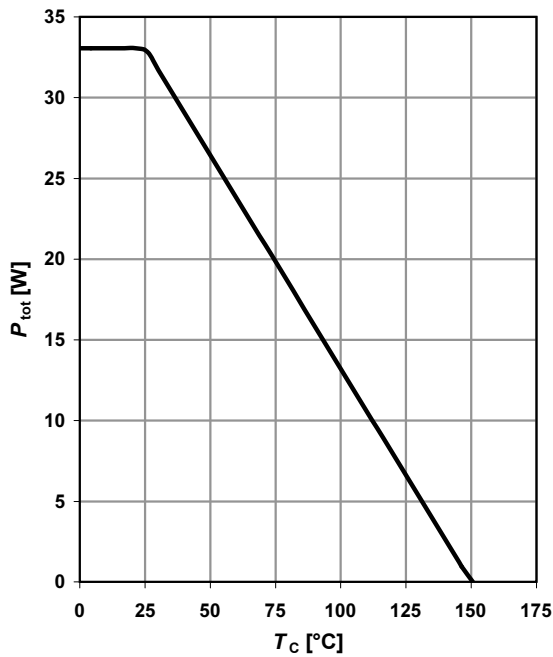

**2 Safe operating area**

$I_D=f(V_{DS}); T_c=25\text{ }^\circ\text{C}; D=0$

parameter:  $t_p$

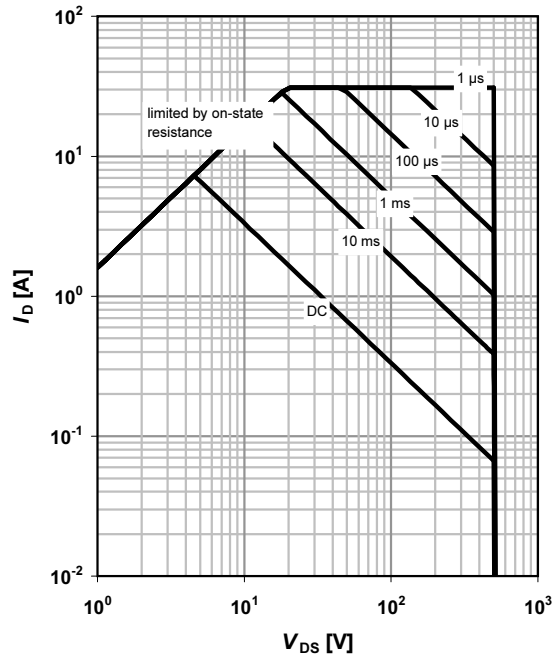

**3 Max. transient thermal impedance**

$Z_{(thJC)}=f(t_p)$

parameter:  $D=t_p/T$

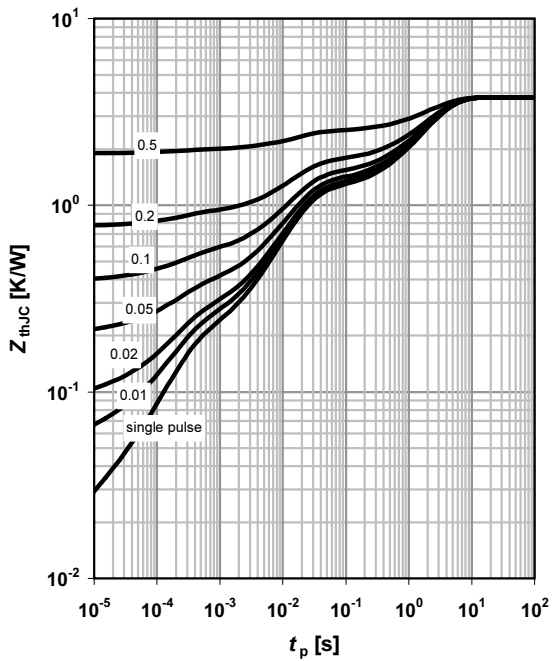

**4 Typ. output characteristics**

$I_D=f(V_{DS}); T_j=25\text{ }^\circ\text{C}$

parameter:  $V_{GS}$

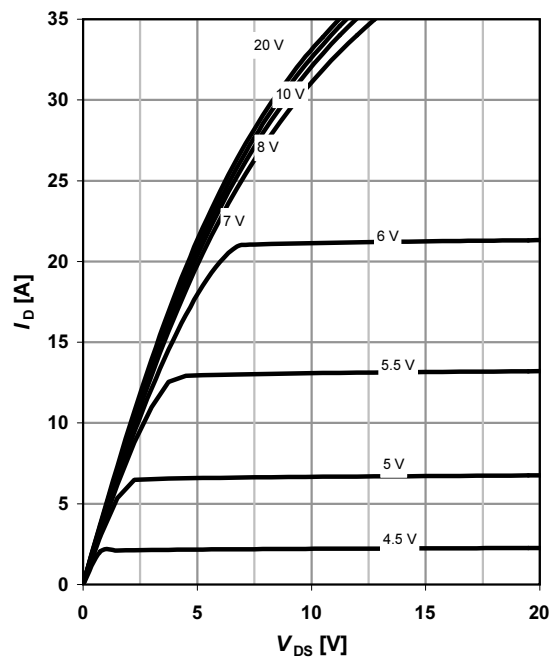

**5 Typ. output characteristics**

$I_D = f(V_{DS}); T_j = 150\text{ °C}$

parameter:  $V_{GS}$

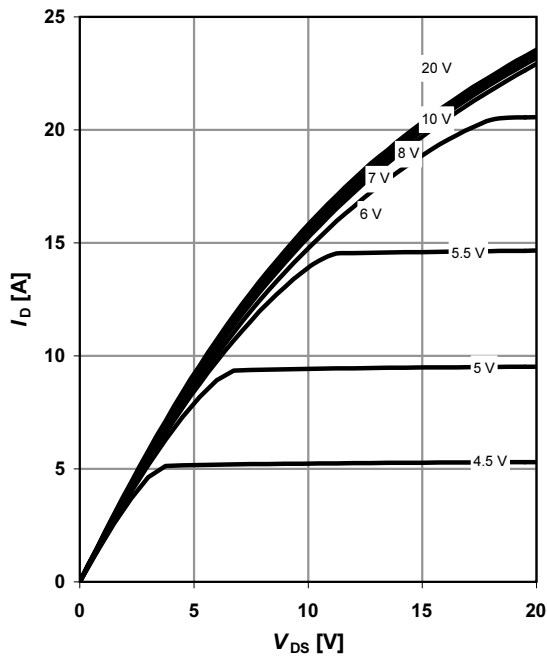

**6 Typ. drain-source on-state resistance**

$R_{DS(on)} = f(I_D); T_j = 150\text{ °C}$

parameter:  $V_{GS}$

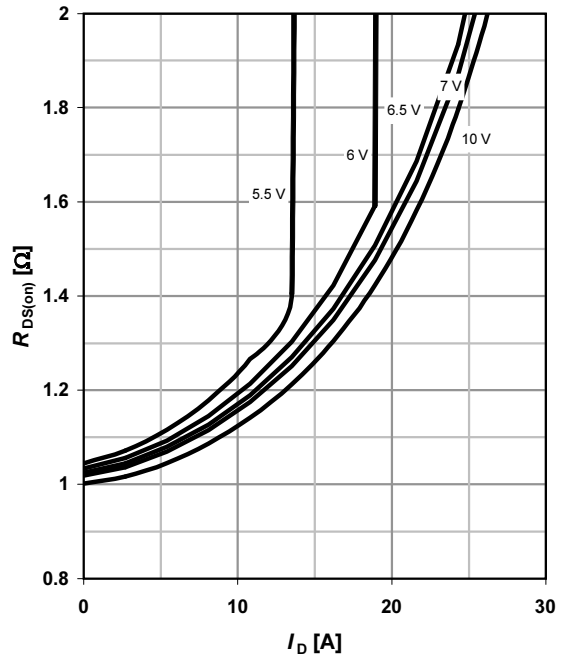

**7 Drain-source on-state resistance**

$R_{DS(on)} = f(T_j); I_D = 7.8\text{ A}; V_{GS} = 10\text{ V}$

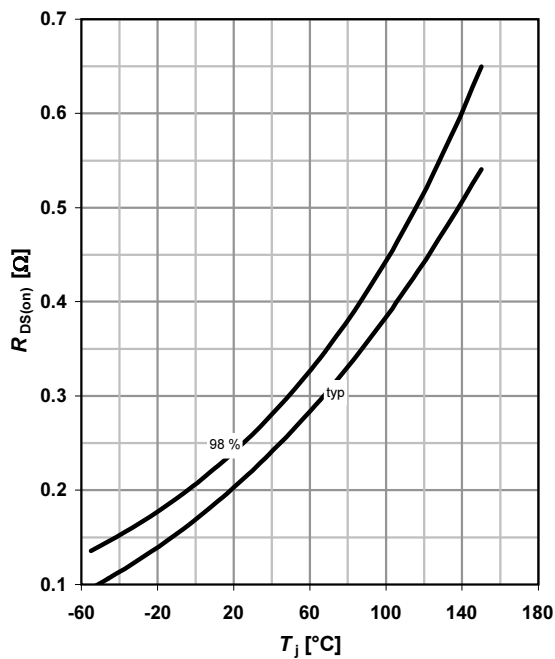

**8 Typ. transfer characteristics**

$I_D = f(V_{GS}); |V_{DS}| > 2|I_D|R_{DS(on)max}$

parameter:  $T_j$

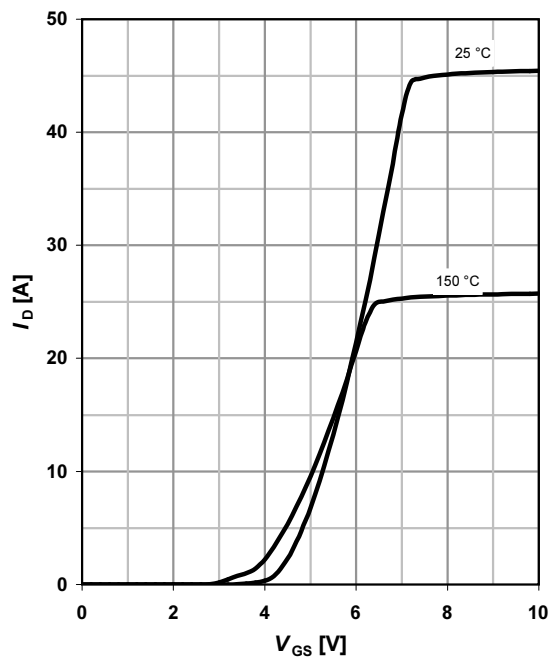

**9 Typ. gate charge**

$V_{GS}=f(Q_{gate}); I_D=7.8 \text{ A pulsed}$

parameter:  $V_{DD}$

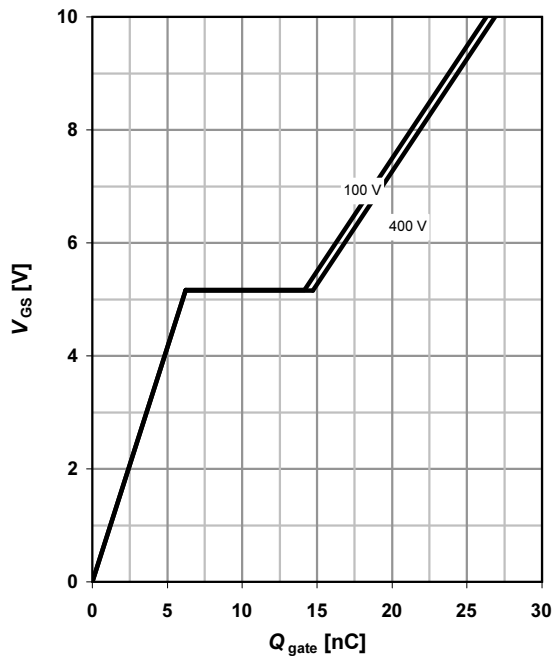

**10 Forward characteristics of reverse diode**

$I_F=f(V_{SD})$

parameter:  $T_j$

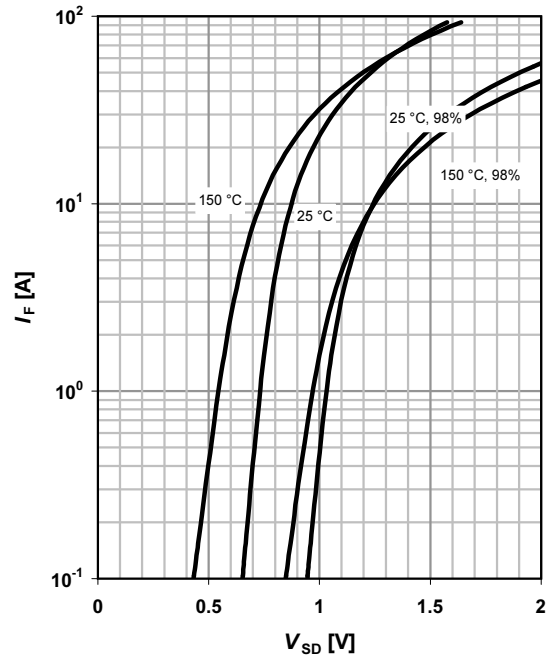

**11 Avalanche energy**

$E_{AS}=f(T_j); I_D=5.2 \text{ A}; V_{DD}=50 \text{ V}$

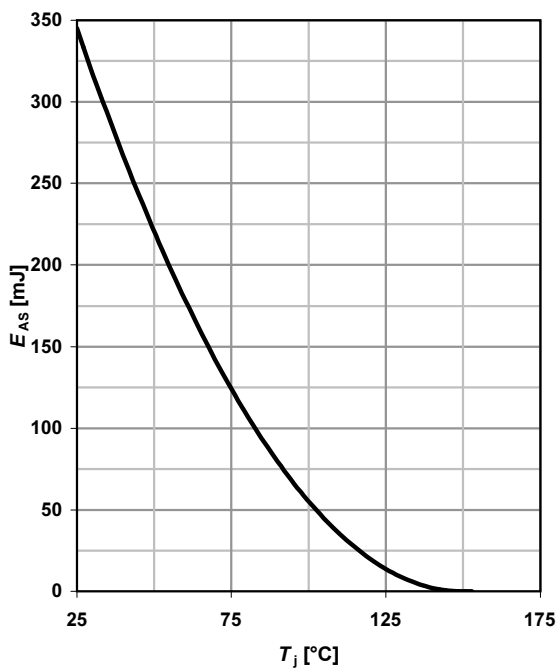

**12 Drain-source breakdown voltage**

$V_{BR(DSS)}=f(T_j); I_D=0.25 \text{ mA}$

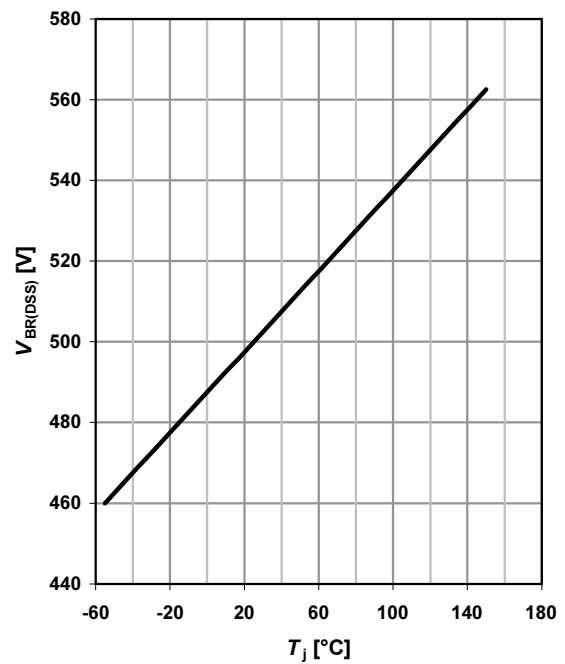

**13 Typ. capacitances**

$C = f(V_{DS}); V_{GS} = 0 \text{ V}; f = 1 \text{ MHz}$

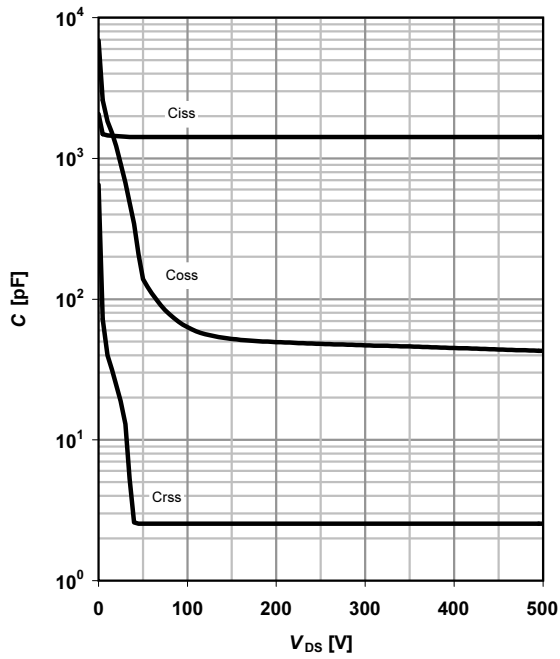

**14 Typ. Coss stored energy**

$E_{oss} = f(V_{DS})$

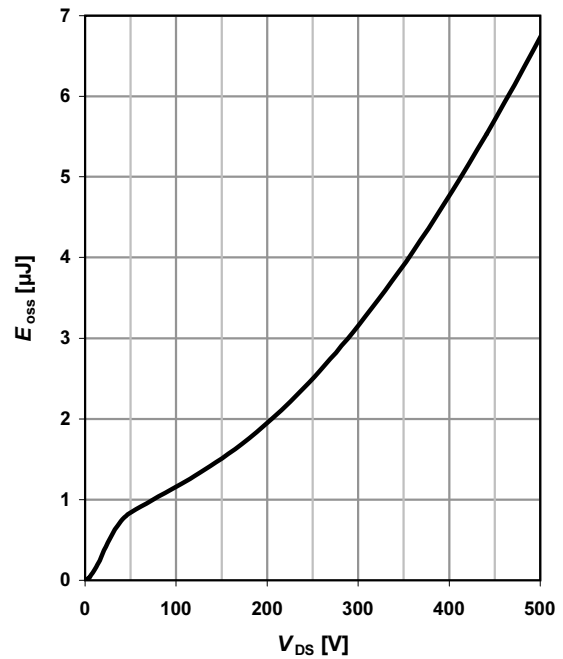

Definition of diode switching characteristics

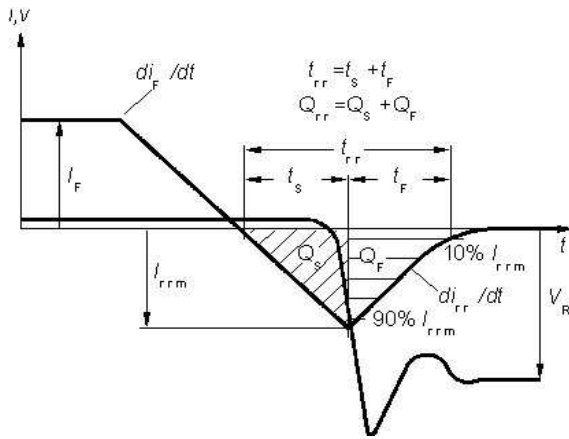

Outline PG-TO220 FullIPAK

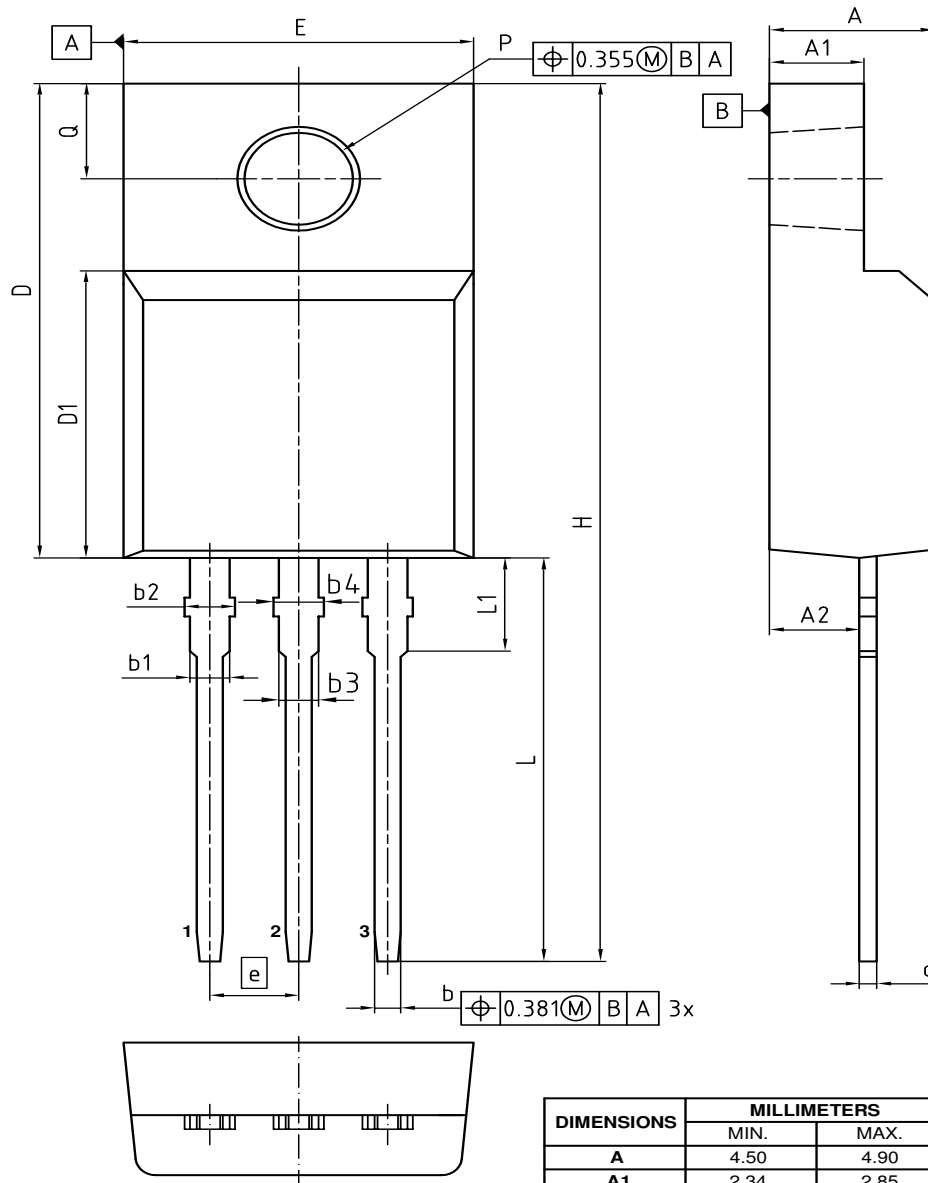

NOTES:  
 ALL DIMENSIONS REFER TO JEDEC STANDARD TO-281  
 AND DOES NOT INCLUDE MOLD FLASH, PROTRUSIONS  
 OR GATE BURRS  
 GATE BURRS ARE LESS THAN 0.5 mm

| DIMENSIONS | MILLIMETERS |       |
|------------|-------------|-------|
|            | MIN.        | MAX.  |
| <b>A</b>   | 4.50        | 4.90  |
| <b>A1</b>  | 2.34        | 2.85  |
| <b>A2</b>  | 2.42        | 2.86  |
| <b>b</b>   | 0.65        | 0.90  |
| <b>b1</b>  | 0.95        | 1.38  |
| <b>b2</b>  | 0.95        | 1.51  |
| <b>b3</b>  | 0.65        | 1.38  |
| <b>b4</b>  | 0.65        | 1.51  |
| <b>c</b>   | 0.40        | 0.63  |
| <b>D</b>   | 15.67       | 16.15 |
| <b>D1</b>  | 8.97        | 9.83  |
| <b>E</b>   | 10.00       | 10.65 |
| <b>e</b>   | 2.54        |       |
| <b>H</b>   | 28.70       | 29.75 |
| <b>L</b>   | 12.78       | 13.75 |
| <b>L1</b>  | 2.83        | 3.45  |
| <b>øP</b>  | 3.00        | 3.30  |
| <b>Q</b>   | 3.15        | 3.50  |

|                                    |
|------------------------------------|
| <b>DOCUMENT NO.</b><br>Z8B00003319 |
| <b>REVISION</b><br>07              |
| <b>SCALE 5:1</b><br>0 1 2 3 4 5mm  |
| <b>EUROPEAN PROJECTION</b><br>     |
| <b>ISSUE DATE</b><br>27.01.2017    |

# 500V CoolMOS™ CP Power Transistor

## IPA50R250CP

### Revision History

IPA50R250CP

**Revision: 2018-02-26, Rev. 2.1**

Previous Revision

| Revision | Date       | Subjects (major changes since last revision) |
|----------|------------|--|
| 2.1      | 2018-02-26 | Outline PG-TO220 FullPAK update              |

#### Trademarks of Infineon Technologies AG

AURIX™, C166™, CanPAK™, CIPOS™, CoolGaN™, CoolMOS™, CoolSET™, CoolSiC™, CORECONTROL™, CROSSAVE™, DAVE™, DI-POL™, DrBlade™, EasyPIM™, EconoBRIDGE™, EconoDUAL™, EconoPACK™, EconoPIM™, EiceDRIVER™, eupec™, FCOS™, HITFET™, HybridPACK™, Infineon™, ISOFACE™, IsoPACK™, i-Wafer™, MIPAQ™, ModSTACK™, my-d™, NovalithIC™, OmniTune™, OPTIGA™, OptiMOS™, ORIGA™, POWERCODE™, PRIMARION™, PrimePACK™, PrimeSTACK™, PROFET™, PRO-SIL™, RASIC™, REAL3™, ReverSave™, SatRIC™, SIEGET™, SIPMOS™, SmartLEWIS™, SOLID FLASH™, SPOC™, TEMPFET™, thinQ!™, TRENCHSTOP™, TriCore™.

Trademarks updated August 2015

#### Other Trademarks

All referenced product or service names and trademarks are the property of their respective owners.

#### We Listen to Your Comments

Any information within this document that you feel is wrong, unclear or missing at all? Your feedback will help us to continuously improve the quality of this document. Please send your proposal (including a reference to this document) to:

[erratum@infineon.com](mailto:erratum@infineon.com)

#### Published by

**Infineon Technologies AG**

**81726 München, Germany**

**© 2018 Infineon Technologies AG**

**All Rights Reserved.**

#### Legal Disclaimer

The information given in this document shall in no event be regarded as a guarantee of conditions or characteristics ("Beschaffheitsgarantie").

With respect to any examples, hints or any typical values stated herein and/or any information regarding the application of the product, Infineon Technologies hereby disclaims any and all warranties and liabilities of any kind, including without limitation warranties of non-infringement of intellectual property rights of any third party.

In addition, any information given in this document is subject to customer's compliance with its obligations stated in this document and any applicable legal requirements, norms and standards concerning customer's products and any use of the product of Infineon Technologies in customer's applications.

The data contained in this document is exclusively intended for technically trained staff. It is the responsibility of customer's technical departments to evaluate the suitability of the product for the intended application and the completeness of the product information given in this document with respect to such application.

#### Information

For further information on technology, delivery terms and conditions and prices please contact your nearest Infineon Technologies Office ([www.infineon.com](http://www.infineon.com)).

#### Warnings

Due to technical requirements, components may contain dangerous substances. For information on the types in question, please contact the nearest Infineon Technologies Office.

The Infineon Technologies component described in this Data Sheet may be used in life-support devices or systems and/or automotive, aviation and aerospace applications or systems only with the express written approval of Infineon Technologies, if a failure of such components can reasonably be expected to cause the failure of that life-support, automotive, aviation and aerospace device or system or to affect the safety or effectiveness of that device or system. Life support devices or systems are intended to be implanted in the human body or to support and/or maintain and sustain and/or protect human life. If they fail, it is reasonable to assume that the health of the user or other persons may be endangered.



## Стандарт Электрон Связь

Мы молодая и активно развивающаяся компания в области поставок электронных компонентов. Мы поставляем электронные компоненты отечественного и импортного производства напрямую от производителей и с крупнейших складов мира.

Благодаря сотрудничеству с мировыми поставщиками мы осуществляем комплексные и плановые поставки широчайшего спектра электронных компонентов.

Собственная эффективная логистика и склад в обеспечивает надежную поставку продукции в точно указанные сроки по всей России.

Мы осуществляем техническую поддержку нашим клиентам и предпродажную проверку качества продукции. На все поставляемые продукты мы предоставляем гарантию .

Осуществляем поставки продукции под контролем ВП МО РФ на предприятия военно-промышленного комплекса России , а также работаем в рамках 275 ФЗ с открытием отдельных счетов в уполномоченном банке. Система менеджмента качества компании соответствует требованиям ГОСТ ISO 9001.

Минимальные сроки поставки, гибкие цены, неограниченный ассортимент и индивидуальный подход к клиентам являются основой для выстраивания долгосрочного и эффективного сотрудничества с предприятиями радиоэлектронной промышленности, предприятиями ВПК и научно-исследовательскими институтами России.

С нами вы становитесь еще успешнее!

### Наши контакты:

**Телефон:** +7 812 627 14 35

**Электронная почта:** [sales@st-electron.ru](mailto:sales@st-electron.ru)

**Адрес:** 198099, Санкт-Петербург,  
Промышленная ул, дом № 19, литера Н,  
помещение 100-Н Офис 331