

STEP-PS/48AC/24DC/0.5

Primary-switched power supply unit

INTERFACE

Data sheet
106206_en_00

© PHOENIX CONTACT - 09/2014



1 Description

STEP POWER power supplies for installation distributors. The STEP POWER power supply range was developed especially for building automation. The low idling losses and high degree of efficiency ensure maximum energy efficiency. They allow flexible use and can be snapped onto the DIN rail or screwed onto an even surface.

Features

- Easy assembly on the DIN rail or panel
- Maximum energy efficiency thanks to low idling losses
- Quick startup with LED function monitoring
- High operating safety due to long mains buffering under full load and high MTBF (> 500,000 h)
- Can be used worldwide in all industrial sectors due to a wide-range input and an international approval package
- Wide temperature range of -25°C to +70°C
- Parallel connection possible for increased performance and redundancy
- Powerful in its particularly slim design (18 mm)



EXPLOSION HAZARD!

Only remove equipment when it is disconnected and not in the potentially explosive area.



DANGER

The device contains dangerous live elements and high levels of stored energy. Never carry out work when the power is turned on.



Make sure you always use the latest documentation. It can be downloaded from the product at phoenixcontact.net/products.

2 Table of contents

1	Description	1
	Features	1
2	Table of contents	2
3	Ordering data	3
4	Technical data	4
5	Structure	7
6	Block diagram	8
7	Safety notes	8
8	Installation	9
9	Mounting position	9
10	Mounting on DIN rails	10
	Assembly	10
	Removing	10
11	Input	10
	Protection of the primary side	10
	Permissible backup fuse for mains protection	10
12	Output	11
	Protection of the secondary side	11
13	Signaling	11
14	Function	12
	Output characteristic curve	12
	Thermal behavior	12
	Parallel operation	13
	Redundant operation	13
	Increased performance	13

3 Ordering data

Description	Type	Order No.	Pcs. / Pkt.
Primary-switched STEP POWER power supply for DIN rail mounting, input: 1-phase, output: 24 V DC/0.5 A	STEP-PS/48AC/24DC/0.5	2868716	1

Accessories	Type	Order No.	Pcs. / Pkt.
Redundancy module, 5-24 V DC, 2x 5 A, 1x 10 A	STEP-DIODE/5-24DC/2X5/1X10	2868606	1

4 Technical data

Input data	
Nominal input voltage	48 V AC
Input voltage range AC	43 V AC ... 52 V AC
Input voltage range DC	60 V DC ... 80 V DC
AC frequency range	45 Hz ... 65 Hz
Frequency range DC	0 Hz
Current consumption	0.5 A (43 V AC) 0.45 A (48 V AC)
Inrush current limitation	< 10 A (typical)
I^2t	< 0.1 A ² s
Power failure bypass	> 15 ms (48 V AC) > 20 ms (52 V AC)
Typical response time	< 0.5 s
Input fuse, integrated	1.25 A (slow-blow, internal)
Output data	
Nominal output voltage	24 V DC \pm 1 %
Output current	0.5 A (-25°C ... 55°C) 0.55 A (-25 °C ... 40 °C permanent) 1 A (maximum output current)
Control deviation	< 1 % (change in load, static 10 % ... 90 %) < 2 % (change in load, dynamic 10 % ... 90 %) < 0.1 % (change in input voltage \pm 10 %)
Efficiency	> 81 % (for 48 V AC and nominal values)
Residual ripple	< 30 mV _{PP} (20 MHz)
Peak switching voltages	< 20 mV _{PP} (20 MHz)
Connection in parallel	Yes, for redundancy and increased capacity
Connection in series	Yes
Protection against surge voltage on the output	< 35 V DC
Resistance to reverse feed	\leq 35 V DC
Power consumption	
Maximum power dissipation NO-Load	< 0.3 W
Power loss nominal load max.	< 3.4 W
LED status indicator	
Status display	"DC OK" LED green / U _{OUT} > 21.5 V: LED lights up
General data	
Insulation voltage input/output	4 kV AC (type test) 3.75 kV AC (routine test)
Degree of protection	IP20
Protection class	II (in closed control cabinet)
MTBF (IEC 61709, SN 29500)	> 1860000 h (40°C)
Housing material	Polycarbonate
Foot latch material	Plastic POM
Dimensions W / H / D (state of delivery)	18 mm / 90 mm / 61 mm
Weight	0.07 kg

Ambient conditions

Ambient temperature (operation)	-25 °C ... 70 °C (> 55 °C Derating: 2,5 %/K)
Ambient temperature (storage/transport)	-40 °C ... 85 °C
Max. permissible relative humidity (operation)	≤ 95 % (at 25 °C, non-condensing)
Vibration (operation)	< 15 Hz, amplitude ±2.5 mm (according to IEC 60068-2-6) 15 Hz ... 150 Hz, 2.3g, 90 min.
Shock	30g in each direction, according to IEC 60068-2-27
Pollution degree in acc. with EN 50178	2
Climatic class	3K3 (in acc. with EN 60721)

Standards

Electrical Equipment for Machinery	EN 60204 / Surge voltage category III
Safety transformers for power supply units	EN 61558-2-16
Electrical safety (of information technology equipment)	IEC 60950-1/VDE 0805 (SELV)
Electronic equipment for use in electrical power installations	EN 50178/VDE 0160 (PELV)
SELV	IEC 60950-1 (SELV) and EN 60204 (PELV)
Safe isolation	DIN VDE 0100-410
Protection against electric shock, basic requirements for safe isolation in electrical equipment	DIN VDE 0106-101
Limitation of mains harmonic currents	EN 61000-3-2

Approvals

UL approvals	UL/C-UL listed UL 508 UL/C-UL Recognized UL 60950 NEC Class 2 as per UL 1310
--------------	--

Conformance with EMC Directive 2004/108/EC

Noise immunity according to EN 61000-6-2

Electrostatic discharge	EN 61000-4-2	
	Housing	
	Contact discharge	6 kV (Test intensity 3)
	Discharge in air	8 kV (Test intensity 3)
	Comments	Criterion A
Electromagnetic HF field	EN 61000-4-3	
	Housing	
	Frequency range	80 MHz ... 3 GHz
	Field intensity	10 V/m (Test intensity 3)
	Comments	Criterion A
Fast transients (burst)	EN 61000-4-4	
	Input	2 kV (Test intensity 3 - asymmetrical)
	Output	2 kV (Test intensity 3 - asymmetrical)
	Comments	Criterion A
Surge current loads (surge)	EN 61000-4-5	
	Input	1 kV (Test intensity 2 - symmetrical) 2 kV (Test intensity 3 - asymmetrical)
	Output	0.5 kV (Test intensity 1 - symmetrical) 1 kV (Test intensity 2 - asymmetrical)
	Comments	Criterion A
Conducted interference	EN 61000-4-6	
	Input/output	Test intensity 3
	Frequency range	150 kHz ... 80 MHz
	Voltage	10 V
	Comments	Criterion A

Emitted interference in acc. with EN 61000-6-3

Radio interference voltage in acc. with EN 55011	EN 55011 (EN 55022) Class B, area of application: Industry and residential
Emitted radio interference in acc. with EN 55011	EN 55011 (EN 55022) Class B, area of application: Industry and residential

5 Structure

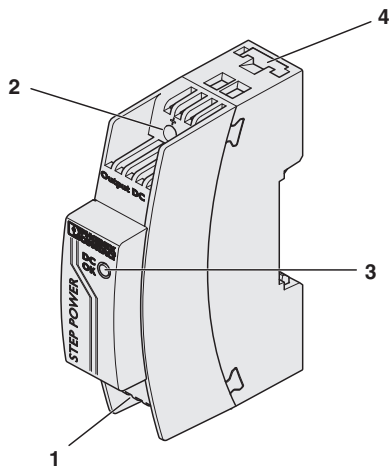

- 1 AC input
- 2 DC output
- 3 "DC OK" LED, green
- 4 Universal snap-on foot for EN DIN rails and for wall mounting

	[mm ²]		AWG	[Nm] Torque
	solid	stranded		
Input	0.2 - 2.5	0.2 - 2.5	24 - 12	0.6 - 0.8
Output	0.2 - 2.5	0.2 - 2.5	24 - 12	0.6 - 0.8

Input data

Nominal input voltage	48 V AC
Input voltage range AC	43 V AC ... 52 V AC
Input voltage range DC	60 V DC ... 80 V DC
AC frequency range	45 Hz ... 65 Hz
Frequency range DC	0 Hz
Input fuse, integrated	1.25 A (slow-blow, internal)
Connection method	Screw connection
Stripping length	6.5 mm

Output data

Nominal output voltage	24 V DC ±1 %
Output current	0.5 A (-25°C ... 55°C) 0.55 A (-25 °C ... 40 °C permanent) 1 A (maximum output current)
Connection method	Screw connection
Stripping length	6.5 mm

6 Block diagram

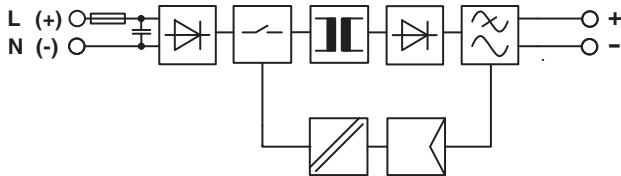

7 Safety notes



EXPLOSION HAZARD!

Only remove equipment when it is disconnected and not in the potentially explosive area.

DANGER

The device contains dangerous live elements and high levels of stored energy.
Never carry out work when the power is turned on.



WARNING:

Before startup please ensure:

The mains connection has been carried out by a competent person and protection against electric shock is guaranteed!

The device can be disconnected outside the power supply unit in accordance with the regulations as in EN 60950 (e.g. through primary side line protection)!

All feed lines are sufficiently protected and dimensioned!

All output lines are dimensioned according to the maximum output current of the device or separately protected!

Sufficient convection must be guaranteed.



CAUTION:

The power supply units are built-in devices. The device may only be installed and put into operation by qualified personnel. The corresponding national regulations must be observed.

8 Installation

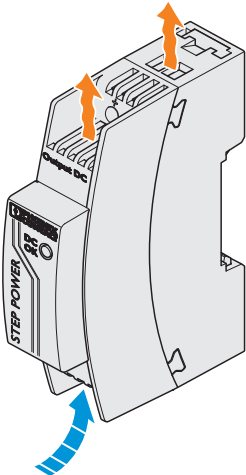

NOTE:
In order to ensure sufficient convection, we recommend a minimum vertical distance of 30 mm to the other devices.



The power supply unit can be snapped onto all DIN rails as per EN 60715; it can also be mounted on walls. The device must be mounted vertically (connecting terminals above or below).

9 Mounting position

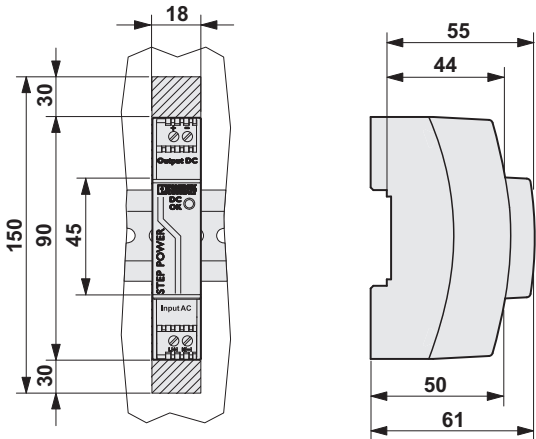

10 Mounting on DIN rails

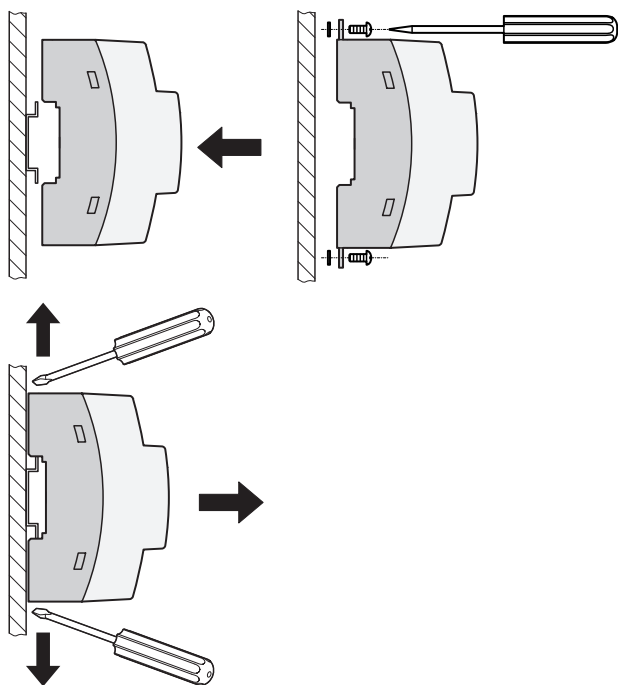

Assembly

To mount on an EN DIN rail, snap the device straight onto the DIN rail.

If the power supply unit is to be fastened directly onto an even surface, press the orange base latch upward and down.

Place a washer between the pulled-out base latch and the even surface (max. outer diameter 8.5 mm, max. thickness 1.3 mm, e.g., spring washer for M4 in acc. with DIN 127-B or toothed lock washer in acc. with DIN 6797).

Then fasten the device with two screws (max. thread diameter 4 mm, max. head diameter 8.5 mm).

Removing

To dismantle from the EN DIN rail, press the orange base latch outward and pull the device off of the DIN rail.

In the case of wall mounting, loosen the screws and press the base latch inwards again.

11 Input

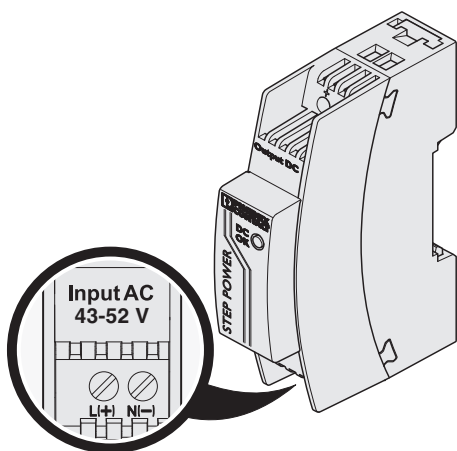

CAUTION:

If an internal fuse is triggered, there is a device malfunction. In this case, the device must be inspected in the factory.

Protection of the primary side

The device must be installed in acc. with the regulations as in EN 60950. It must be possible to disconnect the device using a suitable isolating facility outside the power supply.

The primary side line protection, for example, is suitable. For device protection, there is an internal fuse. Additional device protection is not necessary.

Permissible backup fuse for mains protection

Power circuit-breaker 6 A, 10 A or 16 A, characteristic B (or identical function).

12 Output

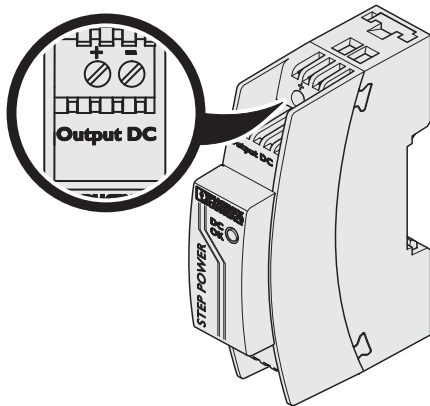

CAUTION:

Make sure that all output lines are dimensioned according to the maximum output current or are separately protected. The cables on the secondary side must have sufficiently large cross sections in order to keep the voltage drops on the lines as low as possible.

The connection is made using the "+" and "-" screw connections on the screw connection of the DC output. The set output voltage is 24 V DC at the time of delivery.

Protection of the secondary side

The device is electronically protected against short-circuit and idling. In the event of a malfunction, the output voltage is limited to 35 V DC.

13 Signaling

The "DC OK" LED enables evaluation of the function of the power supply directly on site.

	State 1	State 2
"DC OK" LED	ON	OFF
Cause	Output voltage > 21.5 V	Output voltage < 21,5 V or no voltage at the output
Meaning	Output voltage and output current OK	The device is in operation, but there is a fault in the consumer, the current consumption is greater than I_1 or the output is short-circuited. The device is out of operation because there is no mains voltage, the fuse on the primary side has been triggered, or the device is faulty.

14 Function

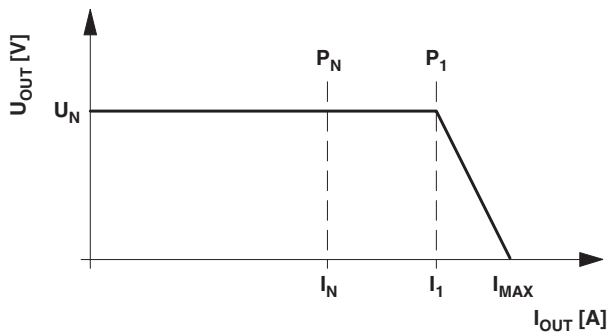

Output characteristic curve

The power supply works with a power reserve as shown in the U/I characteristic curve in the figure. At ambient temperatures $T_{AMB} < +40\text{ °C}$, I_1 is available continuously. At higher temperatures, it is available for a few minutes. In the event of a secondary-side short-circuit or overload, the output current is limited to I_{MAX} . Thereby, the module does not switch off, but rather supplies a continuous output current. The secondary voltage is reduced here until the short-circuit is eliminated. The U/I characteristic curve with the power reserve ensures that both high inrush currents of capacitive loads as well as loads with DC/DC converters in the primary circuit can be supplied.

$$U_N = 24\text{ V}$$

$$I_N = 0.5\text{ A}$$

$$P_N = 12\text{ W}$$

$$I_1 = 0.55\text{ A}$$

$$P_1 = 13.2\text{ W}$$

$$I_{MAX} = 1\text{ A (} U_{OUT} = 0\text{ V)}$$

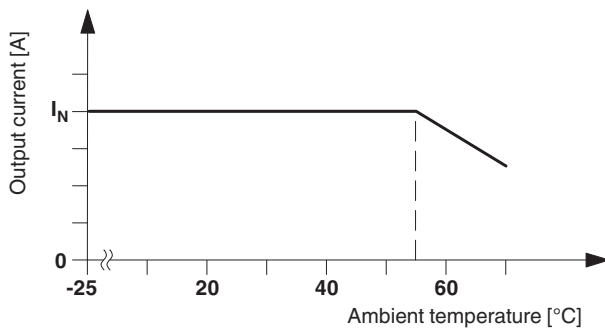

Thermal behavior

With an ambient temperature of up to $+55\text{ °C}$, the device supplies the continuous output current of I_N . In the case of ambient temperatures above $+55\text{ °C}$, the output current must be reduced by 2.5% per Kelvin increase in temperature. The device does not switch off at ambient temperatures of $+70\text{ °C}$ or thermal overload. The output capacity is reduced as far as necessary to provide device protection. After it has cooled down, the output capacity is increased again.

Parallel operation

Devices of the same type can be connected in parallel to increase both redundancy and power. By default upon delivery, no further adjustments are required.

If the output voltage is adjusted, a uniform distribution of power is guaranteed by setting all parallel operated power supply units to exactly the same output voltage.

To ensure symmetrical current distribution we recommend that all cable connections from the power supply unit to the busbar are the same length and have the same cross section. Depending on the system, for parallel connection of more than two power supplies a protective circuit should be installed at each individual device output (e.g., decoupling diode, DC fuse or circuit breaker). This prevents high return currents in the event of a secondary device fault.

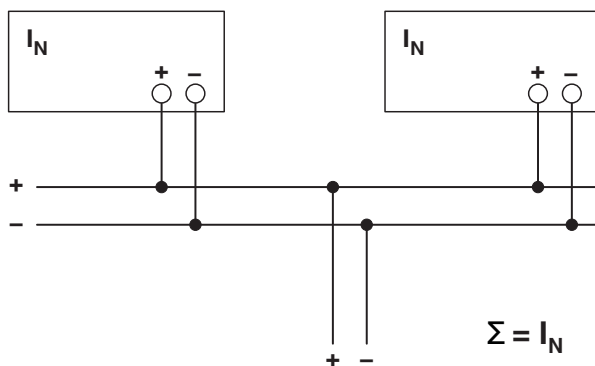

Redundant operation

Redundant circuits are suitable for supplying systems, which place particularly high demands on operational safety. If a fault occurs in the primary circuit of the first power supply unit, the second device automatically takes over the complete power supply without interruption, and vice versa. For this purpose, the power supply units to be connected in parallel must be large enough that the total current requirements of all loads can be fully met by one power supply unit. External decoupling diodes are required for 100% redundancy (STEP-DIODE/5-24DC/2x5/1x10, Order No. 2868606).

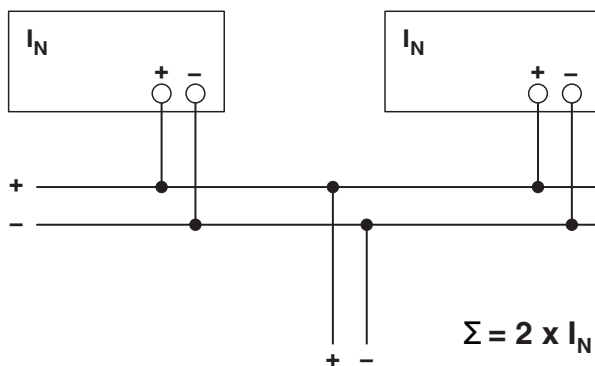

Increased performance

For n parallel connected devices, the output current can be increased to $n \times I_N$. Parallel connection for increasing power is used when extending existing systems. A parallel connection is recommended if the power supply unit does not cover the current consumption of the most powerful load. Otherwise the loads should be divided on individual devices independent from each other.



Стандарт Электрон Связь

Мы молодая и активно развивающаяся компания в области поставок электронных компонентов. Мы поставляем электронные компоненты отечественного и импортного производства напрямую от производителей и с крупнейших складов мира.

Благодаря сотрудничеству с мировыми поставщиками мы осуществляем комплексные и плановые поставки широчайшего спектра электронных компонентов.

Собственная эффективная логистика и склад в обеспечивает надежную поставку продукции в точно указанные сроки по всей России.

Мы осуществляем техническую поддержку нашим клиентам и предпродажную проверку качества продукции. На все поставляемые продукты мы предоставляем гарантию .

Осуществляем поставки продукции под контролем ВП МО РФ на предприятия военно-промышленного комплекса России , а также работаем в рамках 275 ФЗ с открытием отдельных счетов в уполномоченном банке. Система менеджмента качества компании соответствует требованиям ГОСТ ISO 9001.

Минимальные сроки поставки, гибкие цены, неограниченный ассортимент и индивидуальный подход к клиентам являются основой для выстраивания долгосрочного и эффективного сотрудничества с предприятиями радиоэлектронной промышленности, предприятиями ВПК и научно-исследовательскими институтами России.

С нами вы становитесь еще успешнее!

Наши контакты:

Телефон: +7 812 627 14 35

Электронная почта: sales@st-electron.ru

Адрес: 198099, Санкт-Петербург,
Промышленная ул, дом № 19, литера Н,
помещение 100-Н Офис 331