

Model 334C

Advanced PLL HCMOS VCXO



Part Dimensions:
3.2 × 2.5 × 1.1mm • 24mg

Features

- Ceramic Surface Mount Package
- Low Phase Jitter Performance, 600fs Typical
- Advanced PLL Design w/ Low Fundamental Crystal
- Frequency Range 10 – 250MHz *
- +2.5V or +3.3V Operation
- Output Enable Standard
- Tape and Reel Packaging, EIA-418

Applications

- Broadcast Video Systems
- Storage Area Networking
- Broadband Access
- Phase-Locked Loop
- Networking Equipment
- Ethernet/GbE/SyncE
- Fiber Channel
- Test and Measurement

Standard Frequencies

- 50.00MHz
- 77.76MHz
- 100.00MHz
- 122.88MHz
- 125.00MHz
- 155.52MHz
- 156.25MHz
- 200.00MHz

* See Page 7 for additional developed frequencies.
Check with factory for availability of frequencies not listed.

Description

CTS Model 334C is a low cost, high performance PLL voltage controlled oscillator supporting HCMOS output. Employing the latest IC technology, M334C has excellent stability and low phase jitter performance.

Ordering Information

| Model | Output Type | Frequency Code [MHz] | Absolute Pull Range | Frequency Stability | Temperature Range | Supply Voltage | Packaging |
|-------|----------------|-------------------------------------|---------------------|------------------------------|-------------------------|------------------|-----------------------|
| 334 | C | XXX or XXXX | B | 3 | I | 3 | T |
| | Code Output | | Code APR | | Code Temp. Range | | Code Packing |
| | C HCMOS | | B ±50ppm | | C -20°C to +70°C | | T 1k pcs./reel |
| | | | | | I -40°C to +85°C | | |
| | | Code Frequency | | Code Stability | | Code Voltage | |
| | | Product Frequency Code ¹ | | 5 ±25ppm ² | | 2 +2.5Vdc | |
| | | | | 4 ±30ppm | | 3 +3.3Vdc | |
| | | | | 3 ±50ppm | | | |

Notes:

- 1] Refer to document 016-1454-0, Frequency Code Tables.
3-digits for frequencies <100MHz, 4-digits for frequencies 100MHz or greater.
- 2] Check factory availability when paired with "I" temperature code.

**Not all performance combinations and frequencies may be available.
Contact your local CTS Representative or CTS Customer Service for availability.**

This product is specified for use only in standard commercial applications. Supplier disclaims all express and implied warranties and liability in connection with any use of this product in any non-commercial applications or in any application that may expose the product to conditions that are outside of the tolerances provided in its specification.



Electrical Specifications

Operating Conditions

| PARAMETER | SYMBOL | CONDITIONS | MIN | TYP | MAX | UNIT |
|-------------------------|-----------|------------------|-------|-----|-------|------|
| Maximum Supply Voltage | V_{CC} | - | -0.5 | - | 4.0 | V |
| Maximum Control Voltage | V_C | $V_{CC} = +2.5V$ | -0.5 | - | 3.0 | V |
| | | $V_{CC} = +3.3V$ | -0.5 | - | 3.8 | V |
| Supply Voltage | V_{CC} | $\pm 5\%$ | 2.375 | 2.5 | 2.625 | V |
| | | | 3.135 | 3.3 | 3.465 | |
| Supply Current | I_{CC} | Maximum Load | - | 20 | 65 | mA |
| Operating Temperature | T_A | - | -20 | +25 | +70 | °C |
| | | | -40 | - | +85 | |
| Storage Temperature | T_{STG} | - | -55 | - | +125 | °C |

Frequency Stability

| PARAMETER | SYMBOL | CONDITIONS | MIN | TYP | MAX | UNIT |
|---------------------------------|-------------------|--------------------------------------|-----|--------------|-----|------|
| Frequency Range | f_O | - | | 10 - 250 | | MHz |
| Frequency Stability [Note 1] | $\Delta f/f_O$ | - | | 25, 30 or 50 | | ±ppm |
| Absolute Pull Range [Note 2] | APR | - | 50 | - | - | ±ppm |
| Aging | $\Delta f/f_{25}$ | First Year @ +25°C, nominal V_{CC} | -3 | - | 3 | ppm |

1.] Inclusive of initial tolerance at time of shipment, changes in supply voltage, load, temperature and 1st year aging.

2.] Minimum guaranteed frequency shift from f_O over variations in temperature, aging, power supply and load.

Output Parameters

| PARAMETER | SYMBOL | CONDITIONS | MIN | TYP | MAX | UNIT |
|------------------------------------|--------------|----------------------------------|-------------|-------|-------------|------|
| Output Type | - | - | | HCMOS | | - |
| Output Load | C_L | - | - | - | 15 | pF |
| Output Voltage Levels | V_{OH} | CMOS Load | $0.9V_{CC}$ | - | - | V |
| | V_{OL} | | - | - | $0.1V_{CC}$ | |
| Output Duty Cycle | SYM | @ 50% Level | 45 | - | 55 | % |
| Rise and Fall Time | T_R, T_F | @ 20%/80% Levels, $C_L = 15pF$ | - | 5 | 10 | ns |
| Start Up Time | T_S | Application of V_{CC} | - | 3 | 5 | ms |
| Enable Function [Tri-State] | | | | | | |
| Enable Input Voltage | V_{IH} | Pin 2 Logic '1', Output Enabled | $0.7V_{CC}$ | - | - | V |
| Disable Input Voltage | V_{IL} | Pin 2 Logic '0', Output Disabled | - | - | $0.3V_{CC}$ | V |
| Disable Current | I_{IL} | Pin 2 Logic '0', Output Disabled | - | 16 | 22 | mA |
| Enable Time | T_{PLZ} | Pin 2 Logic '1', Output Enabled | - | - | 200 | ns |
| Phase Jitter, RMS | t_{jrms} | Bandwidth 12 kHz - 20 MHz | - | 600 | <1000 | fs |
| Period Jitter, RMS | p_{jrms} | - | - | 3.0 | - | ps |
| Period Jitter, pk-pk | p_{jpk-pk} | - | - | 30 | - | ps |

Electrical Specifications

Control Voltage

| PARAMETER | SYMBOL | CONDITIONS | MIN | TYP | MAX | UNIT |
|---------------------|----------------|--|-------------|------|-----|-------|
| Control Voltage | V_C | $V_{CC} = 2.5V$ | 0.2 | 1.25 | 2.3 | V |
| | | $V_{CC} = 3.3V$ | 0.3 | 1.65 | 3.0 | |
| Frequency Deviation | $\Delta f/f_0$ | $V_C = 0.2V$ | -60 to -180 | | ppm | |
| | | $V_C = 2.3V$ | 60 to 180 | | | |
| | | $V_C = 0.3V$ | -60 to -180 | | ppm | |
| | | $V_C = 3.0V$ | 60 to 180 | | | |
| Linearity | L | Best Straight Line Fit | - | - | ±15 | % |
| Gain Transfer | K_V | Pull Sensitivity; @ +1.25V, +25°C Pull Sensitivity; @ +1.65V, +25°C | - | 80 | 260 | ppm/V |
| Input Impedance | Z_{Vc} | - | 1 | - | - | MOhms |
| Modulation Roll-off | - | @ -3dB | 10 | - | - | kHz |
| Transfer Function | - | - | Positive | | - | - |

Enable Truth Table

| Pin 2 | Pin 4 |
|-----------|-----------|
| Logic '1' | Output |
| Open | Output |
| Logic '0' | High Imp. |

Test Circuit

HCMOS

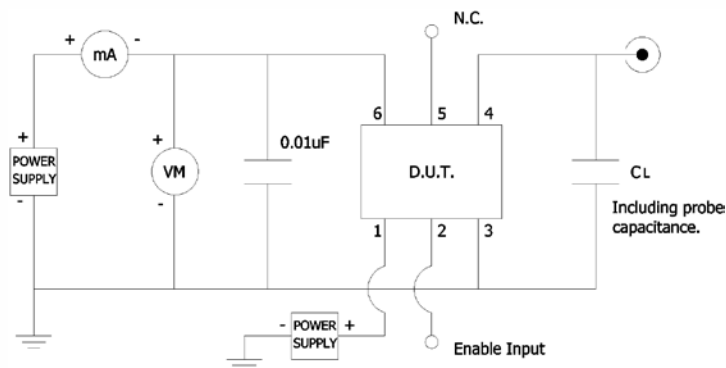

Output Waveform

HCMOS

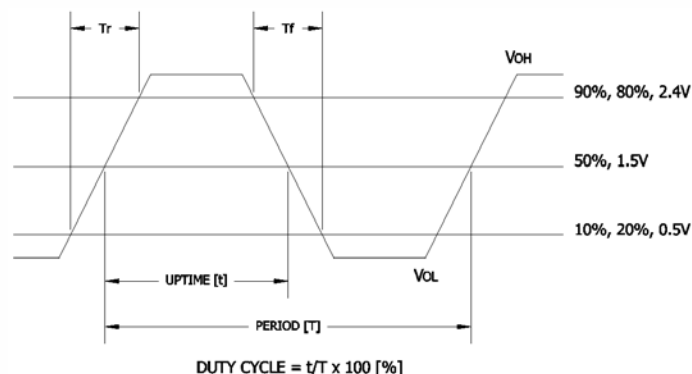



Electrical Specifications

Performance Data

Phase Noise [typical]

125MHz, HCMOS, $V_{CC} = +3.3V$, $V_C = +1.65V$, $T_A = +25^\circ C$



Phase Noise Tabulated

125MHz, HCMOS, $V_{CC} = +3.3V$, $V_C = +1.65V$, $T_A = +25^\circ C$

| PARAMETER | SYMBOL | CONDITIONS | TYP | UNIT |
|--------------------------|---------|-------------------------------------|-----------|--------|
| HCMOS @ 125.00MHz | | | | |
| Phase Noise | | Single Side Band | | |
| | | @ 10Hz | -57.8277 | |
| | | @ 100Hz | -83.0438 | |
| | | @ 1kHz | -107.5582 | |
| | - | @ 10kHz | -124.0745 | dBc/Hz |
| | | @ 100kHz | -127.7532 | |
| | | @ 1MHz | -139.0681 | |
| | | @ 10MHz | -156.3500 | |
| | @ 20MHz | -157.3626 | | |
| Phase Jitter, RMS | tjrms | Integration Bandwidth 12kHz - 20MHz | 530.5330 | fs |

Mechanical Specifications

Package Drawing



Marking Information

1. O – Output Type; C = HCMOS.
 2. ST – Frequency Stability/Temperature Code. [Refer to Ordering Information]
 3. V – Voltage Code; 3 = 3.3V, 2 = 2.5V.
 4. D – Date Code. See Table I for codes.
 5. xxxx – Frequency Code.
3-digits, frequencies below 100MHz
4-digits, frequencies 100MHz or greater
- [See document 016-1454-0, Frequency Code Tables.]

Recommended Pad Layout



Notes

1. JEDEC termination code (e4). Barrier-plating is nickel [Ni] with gold [Au] flash plate.
2. Reflow conditions per JEDEC J-STD-020; +260°C maximum, 20 seconds.
3. MSL = 1.

Pin Assignments

| Pin | Symbol | Function |
|-----|-----------------|--------------------------|
| 1 | V _C | Voltage Control |
| 2 | EOH | Enable [tri-state] |
| 3 | GND | Circuit & Package Ground |
| 4 | Output | RF Output |
| 5 | N.C. | No Connect |
| 6 | V _{CC} | Supply Voltage |

Table I - Date Code

| YEAR | | MONTH | | | JAN | FEB | MAR | APR | MAY | JUN | JUL | AUG | SEP | OCT | NOV | DEC |
|------|------|-------|------|------|-----|-----|-----|-----|-----|-----|-----|-----|-----|-----|-----|-----|
| | | 2001 | 2005 | 2009 | | | | | | | | | | | | |
| 2001 | 2005 | 2009 | 2013 | 2017 | A | B | C | D | E | F | G | H | J | K | L | M |
| 2002 | 2006 | 2010 | 2014 | 2018 | N | P | Q | R | S | T | U | V | W | X | Y | Z |
| 2003 | 2007 | 2011 | 2015 | 2019 | a | b | c | d | e | f | g | h | j | k | l | m |
| 2004 | 2008 | 2012 | 2016 | 2020 | n | p | q | r | s | t | u | v | w | x | y | z |

Packaging - Tape and Reel

Tape Drawing

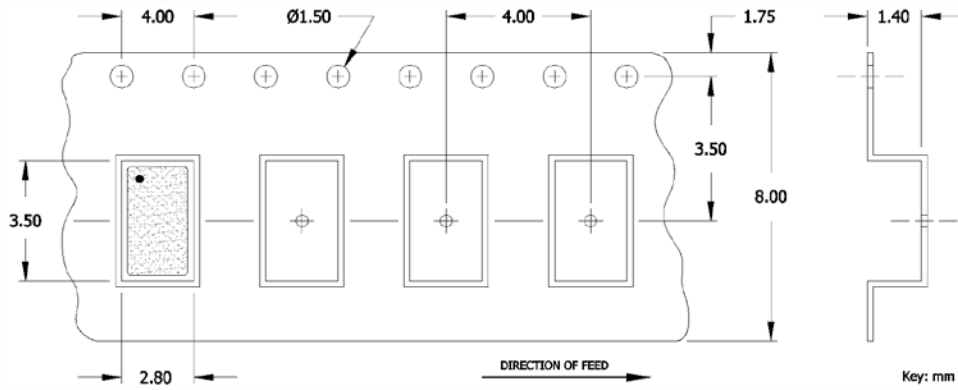

Reel Drawing

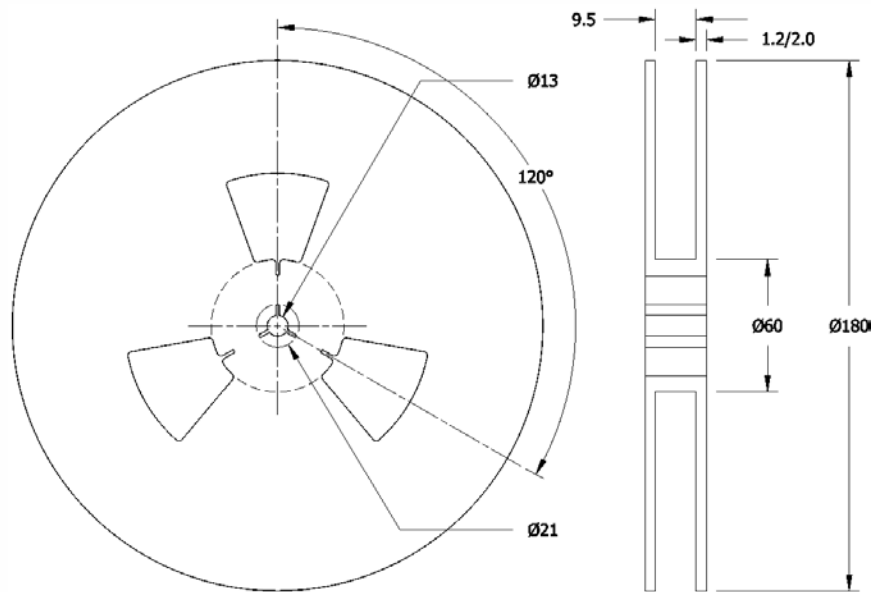

Notes

1. Device quantity is 1k pieces minimum and 3k pieces maximum per 180mm reel.
2. Complete CTS part number, frequency value and date code information must appear on reel and carton labels.



Addendum

Additional Developed Frequencies – MHz

| FREQUENCY | FREQUENCY CODE | FREQUENCY | FREQUENCY CODE | FREQUENCY | FREQUENCY CODE | FREQUENCY | FREQUENCY CODE |
|------------|----------------|------------|----------------|-----------|----------------|-----------|----------------|
| 25.000000 | 250 | 150.000000 | 1500 | | | | |
| 62.500000 | 625 | 153.600000 | 1536 | | | | |
| 106.250000 | 1062 | 250.000000 | 2500 | | | | |
| 132.000000 | 1320 | | | | | | |
| 148.500000 | 1485 | | | | | | |

Frequency Codes for Cover Page Table – MHz

| FREQUENCY | FREQUENCY CODE | FREQUENCY | FREQUENCY CODE |
|------------|----------------|------------|----------------|
| 50.000000 | 500 | 155.520000 | 1555 |
| 77.760000 | 777 | 156.250000 | 1562 |
| 100.000000 | 1000 | 200.000000 | 2000 |
| 122.880000 | 1228 | | |
| 125.000000 | 1250 | | |



Стандарт Электрон Связь

Мы молодая и активно развивающаяся компания в области поставок электронных компонентов. Мы поставляем электронные компоненты отечественного и импортного производства напрямую от производителей и с крупнейших складов мира.

Благодаря сотрудничеству с мировыми поставщиками мы осуществляем комплексные и плановые поставки широчайшего спектра электронных компонентов.

Собственная эффективная логистика и склад в обеспечивает надежную поставку продукции в точно указанные сроки по всей России.

Мы осуществляем техническую поддержку нашим клиентам и предпродажную проверку качества продукции. На все поставляемые продукты мы предоставляем гарантию .

Осуществляем поставки продукции под контролем ВП МО РФ на предприятия военно-промышленного комплекса России , а также работаем в рамках 275 ФЗ с открытием отдельных счетов в уполномоченном банке. Система менеджмента качества компании соответствует требованиям ГОСТ ISO 9001.

Минимальные сроки поставки, гибкие цены, неограниченный ассортимент и индивидуальный подход к клиентам являются основой для выстраивания долгосрочного и эффективного сотрудничества с предприятиями радиоэлектронной промышленности, предприятиями ВПК и научно-исследовательскими институтами России.

С нами вы становитесь еще успешнее!

Наши контакты:

Телефон: +7 812 627 14 35

Электронная почта: sales@st-electron.ru

Адрес: 198099, Санкт-Петербург,
Промышленная ул, дом № 19, литера Н,
помещение 100-Н Офис 331