

Circuits from the Lab[®]
Reference Designs

Circuits from the Lab[®] reference designs are engineered and tested for quick and easy system integration to help solve today's analog, mixed-signal, and RF design challenges. For more information and/or support, visit www.analog.com/CN0332.

Devices Connected/Referenced

ADA4897-2	1 nV/√Hz, Low Power, Rail-to-Rail Output Dual Op Amp
AD8027	Low Distortion, High Speed Rail-to-Rail Input/Output Op Amp
ADCMP601	Rail-to-Rail, Very Fast, 2.5 V to 5.5 V, Single-Supply TTL/CMOS Comparators
ADP1720	50 mA, High Voltage, Micropower Linear Regulator

Magnetostrictive (MR) Rotational Speed Sensor

EVALUATION AND DESIGN SUPPORT

Circuit Evaluation Boards

[CN0332 Evaluation Board \(EVAL-CN0332-PMDZ\)](#)

Design and Integration Files

[Schematics, Layout Files, Bill of Materials](#)

CIRCUIT FUNCTION AND BENEFITS

The circuit shown in Figure 1 is a single-supply, low cost, high-speed magnetostrictive (MR) signal conditioner with a minimum PCB footprint.

The complete signal conditioning solution amplifies the small output voltage of the magnetostrictive sensor and converts it into a digital output signal with a rise and fall time of less than 5 ns and an rms jitter of approximately 100 ps.

The circuit provides a compact and cost effective robust solution for high speed rotational sensing in industrial and automotive applications and is an excellent alternative to Hall effect sensors.

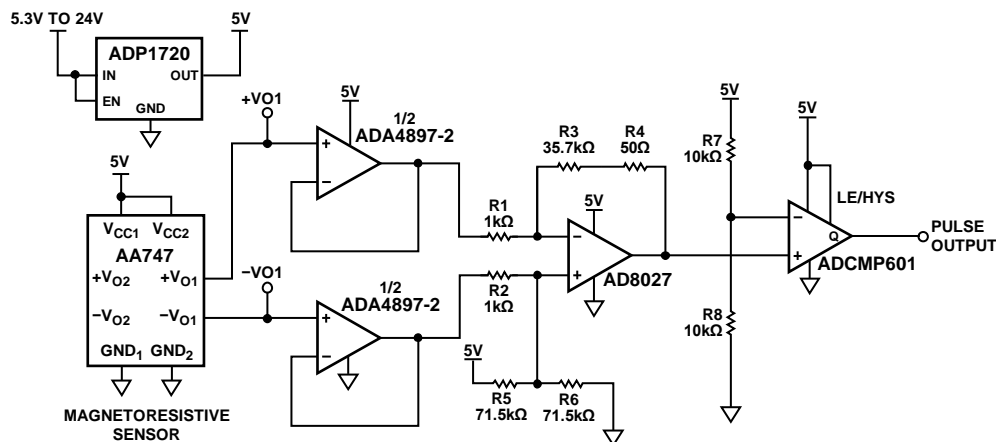

Figure 1. Magnetostrictive Speed Sensing Application Circuit
(Simplified Schematic: All Connections and Decoupling Not Shown)

Rev. 0

Circuits from the Lab[®] reference designs from Analog Devices have been designed and built by Analog Devices engineers. Standard engineering practices have been employed in the design and construction of each circuit, and their function and performance have been tested and verified in a lab environment at room temperature. However, you are solely responsible for testing the circuit and determining its suitability and applicability for your use and application. Accordingly, in no event shall Analog Devices be liable for direct, indirect, special, incidental, consequential or punitive damages due to any cause whatsoever connected to the use of any Circuits from the Lab circuits. (Continued on last page)

CIRCUIT DESCRIPTION

The output of the AA747 Sensitec MR sensor is from a bridge that has a typical output voltage of 30 mV p-p to 100 mV p-p at a common-mode voltage that is equal to one-half the supply voltage. The bridge output impedance is approximately 3 k Ω .

This small signal output of the sensor is first buffered by the ADA4897-2 op amp. The ADA4897-2 dual op amp has a high bandwidth (230 MHz for G = +1) and a rail-to-rail input and output making it an ideal buffer for the sensor signal. Voltage noise is only 1 nV/ $\sqrt{\text{Hz}}$.

The buffered differential signal is then applied to the AD8027 op amp configured as a difference amplifier such that the gain is given by:

$$\text{Gain} = \frac{R3 + R4}{R1},$$

where $R1 = R2$ and $R5 || R6 = R3 + R4$.

The common-mode voltage of 2.5 V is supplied by the R5/R6 voltage divider.

The component values in the circuit are $R1 = R2 = 1 \text{ k}\Omega$, $R5 = R6 = 71.5 \text{ k}\Omega$, $R3 = 35.7 \text{ k}\Omega$, and $R4 = 50 \Omega$. These values provide a gain of 35.75.

The feedback resistor is composed of $R3 + R4$ so that the standard resistor values can be used to create required value of 35.75 k Ω .

The AD8027 is also a high bandwidth (190 MHz, G = +1) rail-to-rail amplifier with a slew rate of 100 V/ μs . It is stable at high gains and is ideally suited to amplify the small signal output of magnetoresistive sensors.

The output of the AD8027 drives the ADCMP601, a very fast single supply rail-to-rail TTL/CMOS comparator with a propagation delay of only 3.5 ns and a minimum pulse width of 3 ns.

The ADP1720 low dropout linear regulator is used to isolate the circuit from noise that can occur in harsh environments.

The ADA4897-2, AD8027, ADCMP601, and ADP1720 all come in small packages, such as TSOT, MSOP, and SC-70, making the circuit well suited to applications requiring minimal PCB area.

Magnetoresistive Sensors

Magnetoresistance is the property of a ferromagnetic material where its resistance changes in the presence of an external magnetic field. A magnetoresistive (MR) element is produced by the deposition of a thin film of permalloy (20% Fe, 80% Ni) which gives it a preferred magnetization direction. In the presence of an external magnetic field parallel to the plane of the permalloy but perpendicular to the current flow, the internal magnetization vector of the permalloy will rotate an angle α and cause a change in the resistance of the permalloy with respect to that angle. This is mathematically expressed in the equation below. R_0 and ΔR are properties of the permalloy, and ΔR has a typical range of 2% to 3%.

$$R = R_0 + \Delta R \cos^2 \alpha$$

The resistance of the MR element is at a maximum when α is 0°. The above equation suggests a non-linear performance, but it can be linearized using barber poles that provides a linear response at a certain range (see Circuit Note CN-0323, *Magnetoresistive Angle Measurement*).

A complete MR sensor is made up of four magnetoresistive elements arranged in a bridge configuration, resulting in a nearly linear differential output signal. Also, the inherent temperature coefficients of the four MR elements are mutually compensated by the bridge configuration.

MR sensors are good alternatives to Hall-effect sensors for low magnetic field applications due to their high magnetic field sensitivity. They are popular because of their non-contact operation that makes them immune to wear and friction. Their rugged construction provides high reliability, and they are relatively insensitive to vibrations mechanical stress. They have a wide operating frequency range (0 Hz to 1 MHz), high operating temperature, low cost, small size, and fast response times. They are particularly popular in rotational speed sensing because of their high sensitivity that can measure weak magnetic fields and also detect zero speed. MR sensors are therefore very popular in industrial and automotive applications.

The output voltage of MR sensors are comparatively larger than Hall effect sensors, resulting to a better signal-to-noise ratio and EMC. Because of its higher sensitivity, a larger air gap between the MR sensor and the target wheel is allowed. Less strict tolerances in sensor housing and mechanical setups are possible reducing cost and complexity of the design. MR sensors are also more cost effective because of the additional cost of the magnets required for Hall effect sensors.

MR sensors are therefore very popular in rotational speed sensing, especially in industrial and automotive applications.

Rotational Speed Sensing

The application circuit shown in Figure 1 measures rotational speed using a magnetoresistive sensor and translates it to a pulse output.

In contrast to rotational speed measurement applications using inductive sensors, the output signal level of MR sensors does not change with respect to the rotational speed, thereby eliminating the need for complicated conditioning electronic that must handle wide dynamic ranges. In addition, the relatively simple conditioning circuits generate pulse outputs with low jitter.

MR sensors are used in rotational speed sensing by measuring the period between ferromagnetic marks, either from the gears of a passive target or the magnetic elements of an active target. Using MR sensors for this application is based on the change in

the MR sensor’s resistivity with respect to changes in the magnetic field lines with respect to the position of the target gear.

MR sensors are able to measure very slow rotations as low as 0 Hz. The sine wave as shown in Figure 2 is the typical output of an MR sensor sensing one tooth of a passive gear wheel. The output voltage is at its peak when the magnetic field lines are parallel to the direction of motion. One period of the sine wave (T) is equivalent to one gear tooth, hence the period for one full revolution can be calculated by multiplying the period of the sine wave by the number of gear teeth (n). The speed (rpm) can be derived by the inverse period and shown in the following equation:

$$RPM = \frac{1}{nT}$$

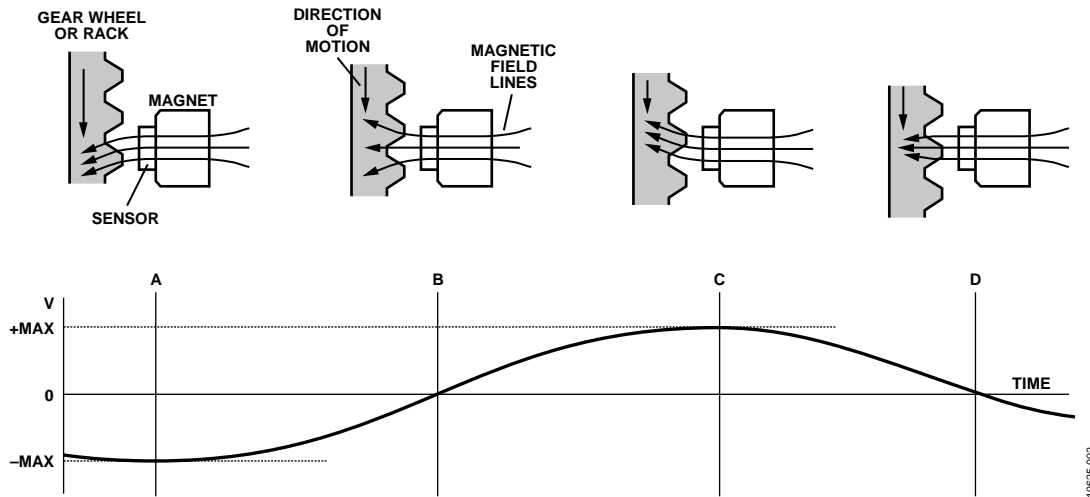

Figure 2. MR Sensor Output

10625-002

Pulse Measurements

Figure 3 shows final output of the [AD8027](#) gain amplifier and the [ADCMP601](#) comparator when tested using the actual MR sensor (Sensitec AA747) in the [EVAL-CN0332-PMDZ](#) evaluation board.

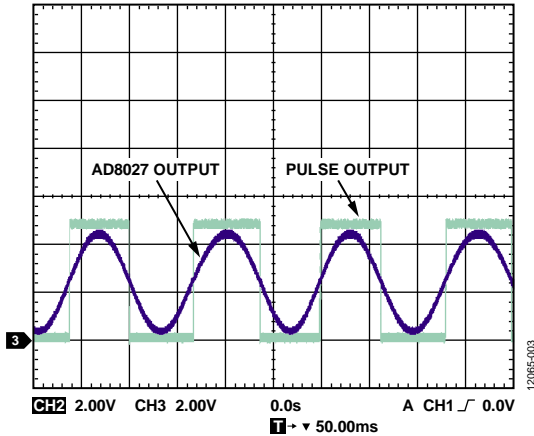

Figure 3. [AD8027](#) Output and Comparator Output for 7.5 Hz MR Sensor Input (Vertical Scale: 2 V/div., Horizontal Scale: 50 ms/div.)

The rise time and fall time of a 1 MHz simulated MR signal taken from the test setup shown in Figure 4 is 3.80 ns and 3.23 ns respectively. The rms jitter is 101.1 ps jitter as shown in Figure 4.

Complete schematics and layout of the printed circuit board can be found in the [CN-0332 Design Support Package](#): www.analog.com/CN0332-DesignSupport.

COMMON VARIATIONS

The devices used in this application circuit were selected for precision, low noise, and high speed. Analog Devices has a wide portfolio of high performance amplifiers and provides other products that work with similar performance.

The [ADA4895-2](#) and [ADA4896-2](#) are similar to the [ADA4897-2](#), and are high-speed, low noise, low power dual-channel rail-to-rail amplifiers that are possible alternatives. The [ADA4528-2](#) is a zero drift amplifier for better drift performance.

The [AD8027](#) is a high-speed amplifier with rail-to-rail input and output that operates on low supply voltages and is optimized for high performance and wide dynamic signal range. The [AD8045](#), [ADA4899-1](#), and [AD8099](#) are possible alternatives that work in the circuit. The [AD8028](#) is a dual channel variation of [AD8027](#) for applications requiring multiple channels.

The [ADCMP601](#) is available in 6-lead SC-70, the [ADCMP600](#) is its variant available in 5-lead SC-70 and SOT-23 packages, and the [ADCMP602](#) is available in an 8-lead MSOP package.

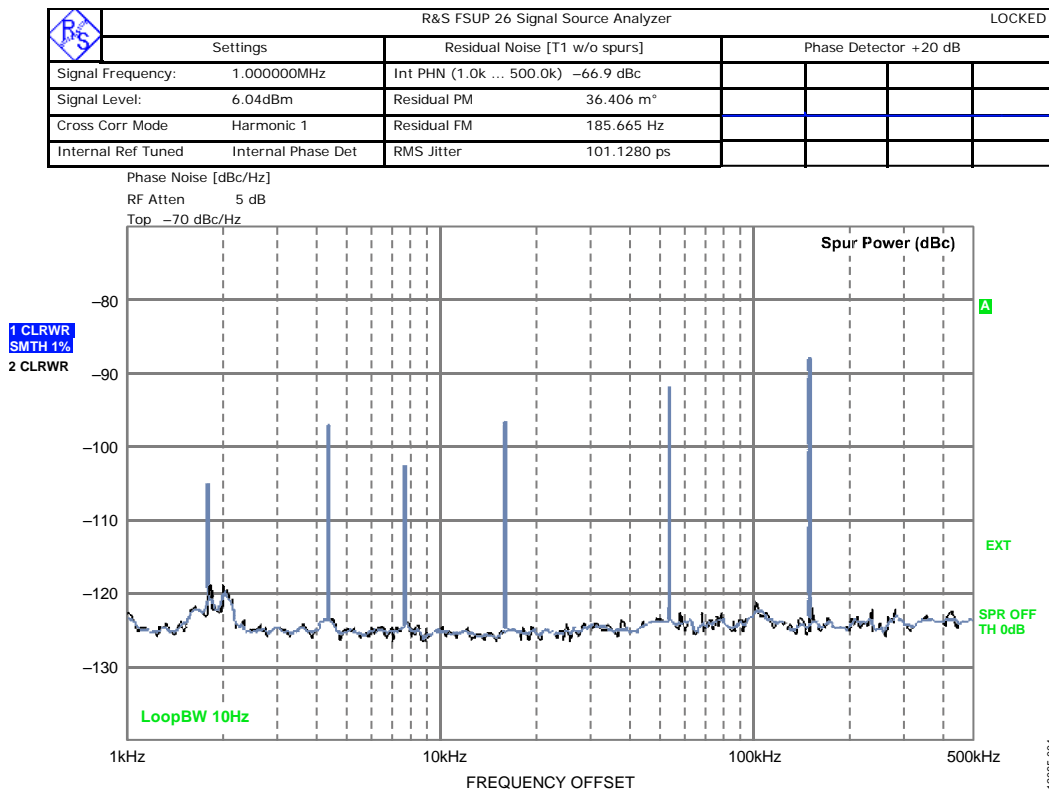

Figure 4. Phase Jitter at 1 MHz with Simulated MR Signal

CIRCUIT EVALUATION AND TEST

Equipment Required

- [EVAL-CN0332-PMDZ](#) evaluation board
- Agilent 33500B series waveform generator or equivalent AWG with dual channel output
- Agilent 3631A dc power supply or equivalent
- Agilent 53210A RF counter or equivalent

Test Setup

A block diagram of the test setup is shown in Figure 5. A dual-channel waveform generator set at a dc offset of half the internal reference supply voltage is simulating the output of a magnetoresistive sensor. The power supply provides 5.5 V to the [CN0332](#) evaluation board. A waveform generator generates two channels of 1 MHz signals at 180 degrees out of phase from each other and configured to sync internally to simulate the differential signal MR output. Both signals are set at a dc offset

of 2.5 V. They are connected to the +VO1 and -VO1 eyelets on the [CN0332](#) board. The AA747 sensor was disconnected for the tests. However, if the signal generator has a low output impedance (50 Ω or less) the sensor can remain connected because its output impedance is 3 k Ω , and the low impedance signal generator will override the sensor output.

If the on-board AA747 MR sensor is used, place the sensor close to the external magnet.

An RF counter then reads the pulse output of the board. Ensure that the ground of the power supply, waveform generator, RF counter and [CN0332](#) evaluation board are common.

The power supply and counter connections are made through the 12-pin PMOD connector.

A photograph of the [CN0332](#) evaluation board is shown in Figure 6.

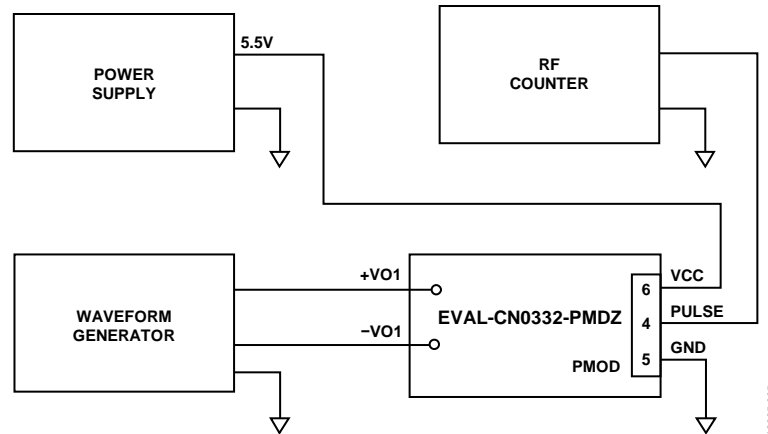

Figure 5. [CN0332](#) Evaluation Board Test Setup

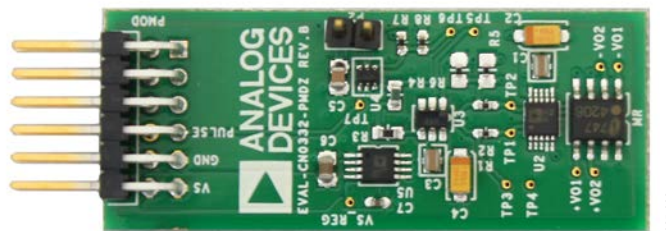

Figure 6. [EVAL-CN0332-PMDZ](#) Evaluation Board

LEARN MORE

CN-0332 Design Support Package:

www.analog.com/CN0332-DesignSupport

CN0323 Circuit Note, *Magnetoresistive Angle Measurement*, Analog Devices.

MT-035 Tutorial, *Op Amp Inputs, Outputs, Single-Supply, and Rail-to-Rail Issues*. Analog Devices.

MT-101 Tutorial, *Decoupling Techniques*. Analog Devices.

AA700 Application Note, *AMR Freepitch Sensors for Angle and Length Measurement*, Sensitec.

Data Sheets and Evaluation Boards

[ADA4897-2 Data Sheet](#)

[AD8027 Data Sheet](#)

[ADCMP601 Data Sheet](#)

[ADP1720 Data Sheet](#)

REVISION HISTORY

1/14—Revision 0: Initial Version

(Continued from first page) Circuits from the Lab reference designs are intended only for use with Analog Devices products and are the intellectual property of Analog Devices or its licensors. While you may use the Circuits from the Lab reference designs in the design of your product, no other license is granted by implication or otherwise under any patents or other intellectual property by application or use of the Circuits from the Lab reference designs. Information furnished by Analog Devices is believed to be accurate and reliable. However, Circuits from the Lab reference designs are supplied "as is" and without warranties of any kind, express, implied, or statutory including, but not limited to, any implied warranty of merchantability, noninfringement or fitness for a particular purpose and no responsibility is assumed by Analog Devices for their use, nor for any infringements of patents or other rights of third parties that may result from their use. Analog Devices reserves the right to change any Circuits from the Lab reference designs at any time without notice but is under no obligation to do so.

©2014 Analog Devices, Inc. All rights reserved. Trademarks and registered trademarks are the property of their respective owners.
CN12065-0-1/14(0)





Стандарт Электрон Связь

Мы молодая и активно развивающаяся компания в области поставок электронных компонентов. Мы поставляем электронные компоненты отечественного и импортного производства напрямую от производителей и с крупнейших складов мира.

Благодаря сотрудничеству с мировыми поставщиками мы осуществляем комплексные и плановые поставки широчайшего спектра электронных компонентов.

Собственная эффективная логистика и склад в обеспечивает надежную поставку продукции в точно указанные сроки по всей России.

Мы осуществляем техническую поддержку нашим клиентам и предпродажную проверку качества продукции. На все поставляемые продукты мы предоставляем гарантию .

Осуществляем поставки продукции под контролем ВП МО РФ на предприятия военно-промышленного комплекса России , а также работаем в рамках 275 ФЗ с открытием отдельных счетов в уполномоченном банке. Система менеджмента качества компании соответствует требованиям ГОСТ ISO 9001.

Минимальные сроки поставки, гибкие цены, неограниченный ассортимент и индивидуальный подход к клиентам являются основой для выстраивания долгосрочного и эффективного сотрудничества с предприятиями радиоэлектронной промышленности, предприятиями ВПК и научно-исследовательскими институтами России.

С нами вы становитесь еще успешнее!

Наши контакты:

Телефон: +7 812 627 14 35

Электронная почта: sales@st-electron.ru

Адрес: 198099, Санкт-Петербург,
Промышленная ул, дом № 19, литера Н,
помещение 100-Н Офис 331